



(12) **DEMANDE DE BREVET CANADIEN
CANADIAN PATENT APPLICATION**

(13) **A1**

(22) Date de dépôt/Filing Date: 2018/10/05
(41) Mise à la disp. pub./Open to Public Insp.: 2019/03/26
(30) Priorité/Priority: 2018/05/21 (US62/674,390)

(51) Cl.Int./Int.Cl. *E21B 43/116* (2006.01),
E21B 43/1185 (2006.01)
(71) Demandeur/Applicant:
OWEN OIL TOOLS LP, US
(72) Inventeurs/Inventors:
LAGRANGE, TIMOTHY E., US;
GARTZ, JEFFREY, US;
LINVILLE, ROCKFORD A., US
(74) Agent: CASSAN MACLEAN IP AGENCY INC.

(54) Titre : TETES DE LANCEMENT A PRESSION DIFFERENTIELLE DESTINEES A DES OUTILS DE TROU DE FORAGE ET METHODES ASSOCIEES
(54) Title: DIFFERENTIAL PRESSURE FIRING HEADS FOR WELLBORE TOOLS AND RELATED METHODS

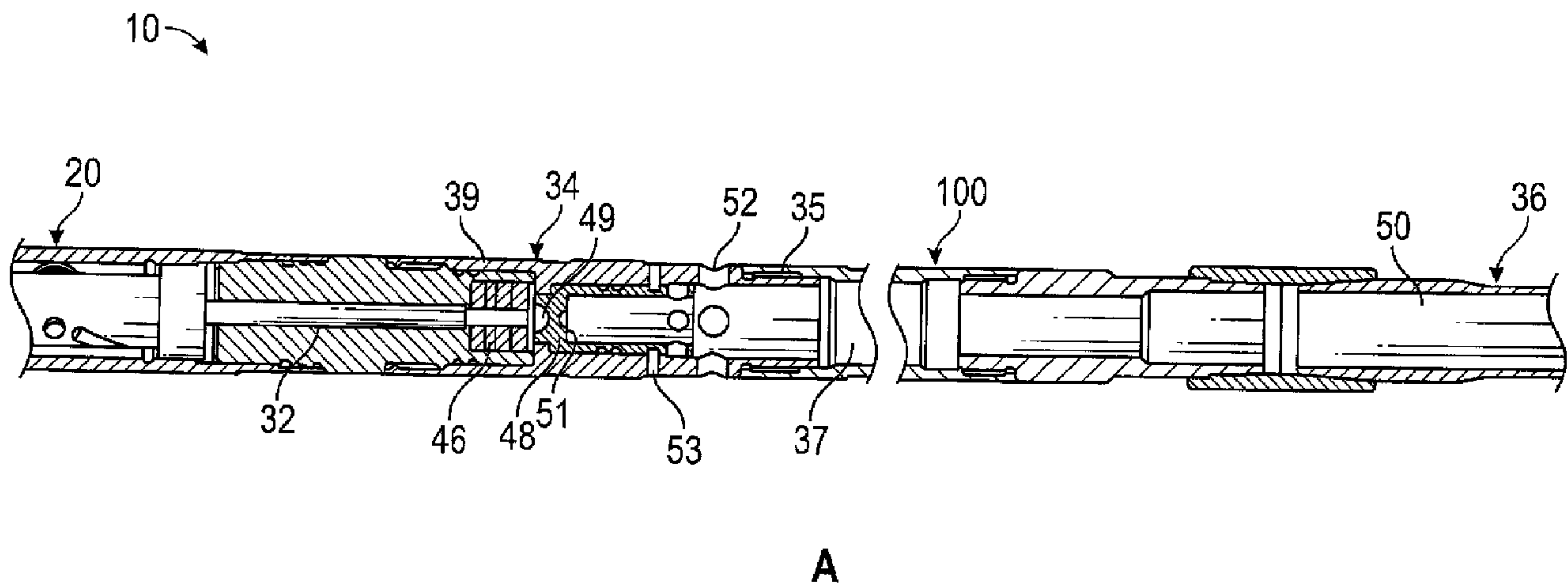

(57) **Abrégé/Abstract:**

A firing head assembly for a well tool includes a shaft, a piston head, a biasing member, and a housing. The shaft has a nose and a terminal end. The shaft also includes a first shoulder and a second shoulder formed between the nose and the terminal end. The piston head slides along the shaft and is positioned between the retaining element and the first shoulder. The biasing member is mounted on the shaft and positioned between the piston head and the second shoulder. The housing has a bore in which the shaft, the piston head, and biasing member are disposed. The housing includes an opening allowing fluid communication between the housing bore and the borehole fluid external to the housing.

ABSTRACT OF THE DISCLOSURE

A firing head assembly for a well tool includes a shaft, a piston head, a biasing member, and a housing. The shaft has a nose and a terminal end. The shaft also includes a first shoulder and a second shoulder formed between the nose and the terminal end. The piston head slides along the shaft and is positioned between the retaining element and the first shoulder. The biasing member is mounted on the shaft and positioned between the piston head and the second shoulder. The housing has a bore in which the shaft, the piston head, and biasing member are disposed. The housing includes an opening allowing fluid communication between the housing bore and the borehole fluid external to the housing.

DIFFERENTIAL PRESSURE FIRING HEADS FOR WELLBORE TOOLS AND RELATED METHODS

TECHNICAL FIELD

[0001] The present disclosure relates to firing heads for actuating downhole tools.

BACKGROUND

[0002] One of the activities associated with the completion of an oil or gas well is the perforation of a well casing. During this procedure, perforations, such as passages or holes, are formed in the casing of the well to enable fluid communication between the wellbore and the hydrocarbon producing formation that is intersected by the well. These perforations are usually made with a perforating gun loaded with shaped charges. The gun is lowered into the wellbore on electric wireline, slickline, tubing or coiled tubing, or other means until it is at a desired target depth; *e.g.*, adjacent to a hydrocarbon producing formation. Thereafter, a surface signal actuates a firing head associated with the perforating gun, which then detonates the shaped charges. Projectiles or jets formed by the explosion of the shaped charges penetrate the casing to thereby allow formation fluids to flow from the formation through the perforations and into the production string for flowing to the surface.

[0003] Many oil well tools deployed on tubing or coiled tubing use pressure-activated firing heads to initiate a detonation train during a desired well operation. In certain aspects, the present disclosure provides pressure-activated firing heads for situations where a differential pressure and a flow source is used to activate a well tool.

SUMMARY

[0004] In aspects, the present disclosure provides a firing head assembly for a well tool. The firing head assembly includes a shaft, a piston head, a biasing

member, and a housing. The shaft has a nose and a terminal end. The shaft also includes a first shoulder and a second shoulder formed between the nose and the terminal end. The piston head slides along the shaft and is positioned between the retaining element and the first shoulder. The biasing member is mounted on the shaft and positioned between the piston head and the second shoulder. The housing has a bore in which the shaft, the piston head, and biasing member are disposed. The housing includes an opening allowing fluid communication between the housing bore and the borehole fluid external to the housing.

[0005] It should be understood that examples certain features of the disclosure have been summarized rather broadly in order that the detailed description thereof that follows may be better understood, and in order that the contributions to the art may be appreciated. There are, of course, additional features of the disclosure that will be described hereinafter and which will in some cases form the subject of the claims appended thereto.

BRIEF DESCRIPTION OF THE DRAWINGS

[0006] For detailed understanding of the present disclosure, references should be made to the following detailed description of the preferred embodiment, taken in conjunction with the accompanying drawings, in which like elements have been given like numerals and wherein:

FIGS. 1A-B schematically illustrate a section of a well tool that uses a signal transfer assembly according to one embodiment of the present disclosure;

FIG. 2 illustrates a side sectional view of a firing head assembly according to one embodiment of the present disclosure in a pre-activated state;

FIG. 3 illustrates a side sectional view of a firing head assembly according to one embodiment of the present disclosure during activation;

FIG. 4 illustrates a side sectional view of a firing head assembly according to one embodiment of the present disclosure after activation;

FIG. 5 illustrates a side sectional view of a well tool that uses a repeater assembly and a firing head assembly according to an embodiment of the present disclosure;

FIG. 6 illustrates a block diagram of a well tool that uses a fluid source, a firing head and downhole device according to an embodiment of the present disclosure;

FIG. 7 illustrates a side sectional view of a well tool that uses a plurality of perforating guns, repeater assembly and a firing head assembly according to an embodiment of the present disclosure;

FIG. 8 illustrates a side sectional view of another firing head assembly according to one embodiment of the present disclosure in a pre-activated state; and

FIG. 9 illustrates a side sectional view of the FIG. 8 firing head assembly after activation.

DETAILED DESCRIPTION

[0007] The present disclosure relates to firing heads for detonating downhole tools. The present disclosure also relates to systems and related methods for transferring signals between two or more downhole tools. The transferred signals may be used to activate one or more of these downhole tools. Exemplary signals may be in the form of kinetic energy, thermal energy, pressure pulses, etc. Signal transfer systems according to the present disclosure receive a signal at one downhole location and transfer that signal to another downhole location. The present disclosure is susceptible to embodiments of different forms. There are shown in the drawings, and herein will be described in detail, specific embodiments of the present disclosure with the understanding that the present disclosure is to be considered an exemplification of the principles of the disclosure, and is not intended to limit the disclosure to that illustrated and described herein.

[0008] Referring to **FIGS. 1A-B**, there is shown a well tool **10** having a first perforating gun **20** and a second perforating gun **30**. The perforating guns **20, 30** are connected by a signal transfer assembly **100**. As discussed in greater detail below, the firing of the first perforating gun **20** initiates a sequence of actions

within the signal transfer assembly **100** that causes the firing of the second perforating gun **30**.

[0009] In one embodiment, the signal transfer assembly **100** may include a first detonator cord **32**, a propellant assembly **34**, a piston chamber sub **35**, a connector tube **36**, a firing head assembly **38**, a detonator **40**, and a second detonator cord **42**. The detonator cords **32**, **42** are formed of conventional energetic material used to detonate shaped charges (not shown). It should be noted that in some arrangements, the detonator cords **32**, **42** may be a part of the perforating guns **20**, **30**. The detonator **40** may be formed of one or more high-explosives, such as RDX (Hexogen, Cyclotrimethylenetrinitramine), HMX (Octogen, Cyclotetramethylenetetranitramine), CLCP, HNS, and PYX. Generally, suitable high-explosives generate a supersonic pressure pulse when detonated.

[0010] The propellant assembly **34** may include a propellant charge **46** formed of an energetic material that generates a high-pressure gas upon activation (e.g., deflagration). The gas is of sufficient volume and high pressure to break one or more frangible elements **53** that retain the piston **48** and propel a piston **48** into a bore **37** of the piston chamber sub **35**. The piston chamber sub **35** is a tubular member configured to "catch" and retain the piston **48**. Suitable materials for propellants may be formed of one or more of ammonium perchlorate, ammonium nitrate, black powder, etc. In contrast, to high-explosives, propellant material is formulated to burn, or "deflagrate," such that the pressure pulse of the generated gas is subsonic.

[0011] The bore **50** of the connector tube **36** is in fluid communication with the bore **37** of the piston chamber sub **35** and with wellbore fluids (not shown) surrounding the well tool **10** via ports **52**, **54**. When in the borehole, wellbore fluids fill the bore **50** and form a liquid column that hydraulically connects the propellant assembly **34** with the firing head assembly **38**. Thus, when the piston **48** moves into the bore **37**, a pressure pulse is applied via the bore **50** to the firing head assembly **38**. Accordingly, the propellant assembly **34** may be considered a

fluid mover; *e.g.*, a device configured to displace fluid toward the firing head assembly **38**.

[0012] Referring to **FIG. 2**, there is shown one non-limiting embodiment of a firing head assembly **38** according to the present disclosure. The firing head assembly **38** may include a housing **60** and a pin assembly **62**. The housing **60** may include an upper housing **61** and a lower housing **63**. The pin assembly **62** and the detonator **40** are serially disposed, *i.e.*, an "end-to-end" arrangement, in a bore **64** of the housing **60**. As described below, the bore **64** includes a plurality of axially and serially aligned bore sections having different geometries and sizes. The serial arrangement enables the transfer of kinetic energy to impact and detonate the detonator **40**. In embodiments, the detonator **40** may be configured to provide a time delay. For example, the detonator **40** may deflagrate to provide a flame output that ignites a time delay fuse and / or a power charge for setting tool. A detonator **40** configured with a time delay fuse may provide a time delay between one and twenty minutes. The time delay fuse is formulated to deflagrate or burn for a preset time (*e.g.*, eight minutes) such that the travel of input signal is delayed by the preset time. A detonator **40** configured with a power charge generates a gas of sufficient volume and pressure to stroke or displace a piston head or other structural member.

[0013] In one embodiment, the pin assembly **62** includes a shaft **66**, a piston head **68**, a biasing member **70**, and one or more frangible members **72**. The shaft **66** may be a solid cylinder having a nose **74**, a terminal end **76**, and annular first and second shoulders **80**, **82**. The shoulders **80**, **82** may be raised surfaces or projections extending from an outer surface of the shaft **66** that present surfaces that can block axial movement. The axial direction is defined as along the direction the shaft **66** translates. The piston head **68** may be an annular disk shaped body that can slide along the shaft **66** and is retained between a retaining element **78** positioned at the terminal end **76** and the first shoulder **80**. The retaining element **78** may be a nut, washer, flange, or other radially enlarged projection formed or attached to the terminal end **76**. In some embodiments, the retaining element **78** may be omitted. The biasing member **70**, which may be a

spring, surrounds the shaft **66** and biases the piston head **68** toward the retaining element **78**. In one arrangement, the biasing member **70** is retained between the second shoulder **82** and the piston head **68**.

[0014] The frangible members **72** may be used to selectively secure the shaft **66** to the outer housing **60**. By "selectively," it is meant that the shaft **66** is stationary relative to the outer housing **60**, and therefore does not impact the detonator **40** until a predetermined amount of pressure is applied to the pin assembly **62**. The frangible members **72** may be bodies such as shear pins that are intentionally constructed to break when subjected to a predetermined loading. The frangible member(s) **72** may also be formed as shoulders, flanges, or other features that connect, either directly or indirectly, the shaft **66** to the housing **60**.

[0015] Referring to **Figs. 1A-B**, and **2**, while being conveyed in the wellbore in the pre-activated position, the firing pin shaft **66** is held in place by the frangible member **72**. In the pre-activated position, the biasing member **70** pushes the piston head **68** up against the retaining element **78** because there is little or no counter-acting pressure on the piston head **68**. The biasing member **70** may be considered to be in an axially expanded state. The piston head **68** is positioned in a first section **96** of the bore **64** that has an inner surface that has an enlarged diameter relative to the outer diameter of the piston head **68**, which forms a passage **90** that allows fluids to flow around the piston head **68** in both directions. Thus, whatever pressure differential is present and acts on the piston head **68** cannot overcome the spring force of the biasing member **70**. That is, as long as low flow rate conditions are present, fluid can flow in both directions axially around and past the piston head **68**. A seal **92** may be used proximate the nose **74** to form a liquid tight-barrier that prevents borehole fluids from contacting the detonator **40**. The small force generated by hydrostatic pressure acting on the seal **92** is insufficient to shear the frangible members **72**.

[0016] Referring to **Figs. 1A-B**, and **3**, when the detonator cord **32** activates the propellant charge **46**, a high-pressure gas is generated. This high-pressure gas breaks the frangible element **53** and pushes the piston **48** into the bore **37**, which creates a pressure pulse in the liquid column in the bore **50**. When subjected to

the pressure pulse in the bore **50**, the piston head **68** slides on the shaft **66**, which is held stationary by the frangible member(s) **72**, until the piston head **68** seats against the first shoulder **80**. The pressure pulse acts on a pressure face of the piston head **68** that is generally transverse to the axial direction of movement of the piston head **68**. When seated, the piston head **68** is positioned in a second reduced-diameter section **98** of the bore that is sized to minimize flow passages around the piston head **68**. Because there is substantially no flow past the piston head **68**, the pressure differential across the piston head **68**, in addition to the hydrostatic pressure acting on the seal **92**, now act on the frangible members **72**. However, the pressure pulse has not yet generated enough force to break the frangible members **72**. By "substantially no flow," it is meant that flow is sufficiently restricted, or there is sufficient hydraulic isolation between the first bore section **96** and the third bore section **102**, to generate the pressure differential required to move the piston head **68**. The position of the piston head **68** may be referred to as a partially activated position.

[0017] Referring to **Figs. 1A-B**, and **4**, the pressure pulse has reached a magnitude that breaks the frangible members **72** (**FIG. 3**) and allows the piston head **68** to push the shaft **66** toward the detonator **40**, which detonates upon impact of the end **74**. The piston head **68** now resides in a third section **102** of the bore **64**. The third section **102** is defined by an inner surface that form a flow passage past the piston head **68**. The housing opening **54** is formed through the inner surface such that the third section **102** may be considered directly radially inward of the housing opening **54**. The position of the piston head **68** may be referred to as a fully activated position. Any pressure above the piston head **68** compresses the biasing member **70** and allows fluid in the bore **64** to vent via the opening **54**. The biasing member **70** also applies force to the pin shaft **66** as it travels, which assists with applying impact force to the impact detonator **40**.

[0018] Referring now to **FIG. 5**, there is shown another embodiment of another well tool **120** according to the present disclosure. The well tool **120** has a first perforating gun **20** and a second perforating gun **30**. The perforating guns **20**, **30** are connected by a repeater assembly **130**, and a signal transfer assembly

140. As discussed in greater detail below, the firing of the first perforating gun **20** initiates a sequence of actions within the repeater assembly **130** and the signal transfer assembly **140** that causes the firing of the second perforating gun **30**.

[0019] The repeater assembly **130** includes a first propellant assembly **160**, a first piston chamber sub **162**, a first connector tube **164**, and a first firing head **146**. The signal transfer assembly **140** includes a second propellant assembly **152**, a second piston chamber sub **154**, a second connector tube **156**, and a second firing head **158**. The details of these components have already been discussed above.

[0020] During use, firing the first perforating gun **20** initiates the detonator cord **32**, which activates the first propellant assembly **160** to generate a high-pressure gas. In a manner previously described, this high-pressure gas enables the propellant assembly **160** to create a pressure pulse in the liquid column in the first connector sub **164**. Upon encountering the pressure pulse, the first firing head **146** activates the second propellant assembly **152**, which creates another pressure pulse in the second connector tube **156**. The second firing head **158** responds to this second pressure pulse by activating the detonator **40**. The detonator **40** fires the second perforating gun **30** in a conventional manner.

[0021] Thus, in the **FIG. 5** embodiment, multiple pressure pulses are sequentially generated to transmit a firing signal between two perforating guns. Specifically, the repeater assembly transmits a pressure pulse in response to receiving a pressure pulse. Such an arrangement may be desirable when two perforating guns are separated by a relatively large axial distance. The spatial separation may be too far for one pressure pulse to travel without being dissipated to a point where insufficient energy is available to appropriately displace a firing head. It should be noted that while one repeater assembly is shown in **FIG. 5**, two or more repeater assemblies may be also be used.

[0022] In the **FIG. 5** arrangement, the first firing head **146** and the second firing head **158** may be configured as firing heads in accordance with the present disclosure. Alternatively, one or both of the firing heads **146**, **158** may use other known pressure actuated firing head configurations. Generally, in order to

function with the **FIG. 5** repeater arrangement, a suitable firing head includes a sliding pin that can be displaced by a pressure pulse. The sliding pin should have sufficient axial stroke to contact and detonate an adjacent detonator.

[0023] Referring to **FIG. 6**, there is shown in functional block diagram of another system **180** according to the present disclosure. The system **180** includes a fluid source **182** and a firing head assembly **38**. Referring to **Figs. 3** and **6**, as described above, the firing head assembly **38** actuates once a predetermined differential pressure acts on the piston head **68**. The fluid source **182** supplies a fluid stream **184** at a flow rate sufficient to generate the predetermined differential pressure to actuate the firing head assembly **38**. The fluid source **182** may be a fluid mover positioned in the wellbore or at the surface. For instance, the fluid source **182** may be a surface pump or a downhole pump. In other embodiments, the fluid source **182** may include a pressure source such as compressed gas that moves fluid when released. It should be noted that in such arrangements, the fluid source **182** replaces the propellant assembly as the fluid mover.

[0024] The firing head assembly **38** may be used to fire a perforating gun as previously described. More generally, the firing head **38** may be used to activate any downhole device **186** that can change operating states in response to an impact or pressure pulse. Illustrative devices include, but are not limited to, perforating guns, power charge activated setting tools, and tubing or casing cutters. If a setting tool is run, then the detonator **40** will be replaced with an igniter.

[0025] Referring to **FIG. 7**, there is shown a well perforating system **190** that utilizes the various devices and components described above. The well perforating system **190** is shown in a well **192** formed below a surface **194**, which may be a dry land surface or a mud line at a subsea location. The wellbore **192** may be drilled in a formation **196** that has several zones **210a-e** from which hydrocarbons are to be produced. As illustrated, the zones **210a-e** may be of different sizes and irregularly spaced apart. Moreover, while five zones are shown, fewer or greater zones may be present and extend across several miles. Embodiments of the present disclosure may be used to perforate all the zones

210a-e during one operation, or "trip," into the wellbore **192**. Further, the perforations may be formed nearly simultaneously and while the perforating system **190** is stationary relative to the wellbore **192**.

[0026] In one embodiment, the well perforating system **190** may include perforating gun sets **200a-e** and detonation transfer assemblies **220a-d** conveyed by a work string **195**. The length of each gun set **200a-e** is selected to best match the associated zone **210a-e**. The length of each signal transfer assembly **220a-d** is selected to position each gun set **200a-e** at the associated zone **210a-e**. In the formation illustrated, detonation transfer assemblies **220a** and **220b** each have two repeater units because of the distances separating formations **210a,b,c**. The distance separating formation **210c** and **210d** is relatively shorter. Therefore, the signal transfer assembly **220c** has only one repeater unit. The distance separating formation **210d** and **210e** is the longest and requires the signal transfer assembly **220d** to have three repeater units.

[0027] The work string **195** may be coiled tubing or drill pipe. In other arrangements, the work string **195** may be electric wireline, slickline, or other rigid or non-rigid carriers.

[0028] In an exemplary use, the formation traversed by the wellbore **192** is logged to determine the location of each of the zones **210a-e**. Conventionally, the locations are with reference to the "measured depth," which is the distance along the wellbore **192**. Thereafter, the perforating system **190** is assembled to position each of the perforating gun sets **200a-e** at an associated zone **210a-e**. Next, the perforating assembly **190** is conveyed into the wellbore and positioned using the information acquired from the prior logging and information being acquired while conveying. Referring to **Figs. 1A-B** and **3**, and **7**, At this time, wellbore fluid flows via the ports **52**, **54** into the bore **50** of the connector tube **36** and the interior of the firing head assembly **38**. Thus, a liquid column hydraulically connects the propellant assembly **34** to the firing head assembly **38**.

[0029] Once properly positioned, a firing signal is sent to detonate the first perforating gun **200a**. The firing of the first perforating gun **200a** is transmitted via the first detonation transfer unit **220a** to the second gun set **200b**. The firing

of the second gun set **200b** is transmitted via the second detonation transfer unit **220b** to the third gun set **200c**. The firing signals are conveyed in this manner until the final gun set **200e** is fired. It should be appreciated that the formations **210a-e** have all been perforated at the same time and while the perforating system **190** is stationary in the wellbore **192**. If present, time delay fuses would have inserted delays between the firings. Thereafter, the entire perforating system **190** may be retrieved from the wellbore **192**.

[0030] Referring to **FIG. 8**, there is shown another non-limiting embodiment of a firing head assembly **238** according to the present disclosure. The **FIG. 8** embodiment is, in certain aspects, similar to the **FIG. 2** embodiment in the following aspects. The firing head assembly **238** may include a housing **260** and a pin assembly **262**. The pin assembly **262** and a detonator **40** are serially disposed, *i.e.*, an "end-to-end" arrangement, in a bore **264** of the housing **260**. The serial arrangement enables the transfer of kinetic energy to impact and detonate the detonator **40**. The pin assembly **262** includes a shaft **266**, a piston head **268**, a biasing member **282**, and one or more frangible members **272**. The shaft **266** may be a solid cylinder having a nose **274**.

[0031] Different from the **FIG. 2** embodiment, the firing head **238** is configured to selectively seal off an opening **254** in the housing **260** that allows wellbore fluid surrounding the firing head **238** to enter and fill the bore **264** of the housing **260**. Also, the seal allows the system **100** to be removed from a live well. The bore **264** is formed of several interconnected bore sections, which are discussed below. In one embodiment, the firing head **238** may include a shifting sleeve **280** that is disposed around a portion of the pin shaft **266**.

[0032] The shifting sleeve **280** may be a tubular member having an outer circumferential surface **281** and an inner circumferential surface **284** that defines a passage **286**. The passage **286** has a sufficiently large diameter to allow the piston head **268** to translate at least partially through the shifting sleeve **280**. In a pre-activated position, the frangible member **272** prevents the shaft **266** from sliding axially toward the detonator **40**. The frangible member **272** may be a shear flange or other inwardly projecting portion of the shifting sleeve **280**. The

frangible member **272** may interferingly engage a shoulder **273** formed on the shaft **266** to stop axial movement toward the detonator **40**. The outer surface **282** includes sealing members **288**.

[0033] The sleeve **280** translates within a bore section **290** from a pre-activated position shown in **FIG. 8** in which the opening **254** is unblocked to an activated position shown in **FIG. 9** wherein the opening **254** is blocked. When the pressure pulse acts on the piston head **268**, the frangible member **272** breaks and allows the shaft **266** to travel axially toward the detonator **40**. The frangible member **272** may disintegrate or remain as a collar or ring **272** as shown.

[0034] The shifting sleeve **280** is displaced from the pre-activated position to the activated position using ambient wellbore fluid pressure. In one embodiment, the housing **260** may include a fluid path **300** that connects a bore section **302** in which the pin shaft **266** slides axially. The fluid path **300** is in fluid communication with one or more passages **304**, each of which includes a piston **306**. Each piston **306** includes a pressure face **308** in fluid communication with the fluid path **300** via the passage **304** and a contact end **310** for physically contacting the shifting sleeve **280**. The pistons **306** translates from a pre-activated position shown in **FIG. 8** to an activated position shown in **FIG. 9** in their respective passages **304** when sufficient pressure is present in the passage(s) **304**.

[0035] Referring to **FIG. 9**, the fluid circuit by which fluid flows to the pistons **306** will be described. The pin shaft **266** includes a reduced diameter section **320** that forms an annular passage **322** defined by an outer surface of the pin shaft **266** and an inner surface of a bore section **324** adjacent to a bore section **302**. Thus, fluid in the bore section **302** flows along the annular passage **322** to the fluid path **300**. The fluid path **300** communicates the fluid to one or more passages **304**. Upon entering the passages **304**, the fluid can act on the piston(s) **306**.

[0036] It should be noted that the seals **92** disposed on the pin shaft **266** provide selective fluid tight sealing for the fluid path **300**. As shown in **FIG. 8**, the seals **92** form a fluid barrier that blocks fluid flow across the annular passage **322**. Thus, the fluid path **300** is isolated from ambient borehole pressures. Fluid

in the fluid path **300** and the passage(s) **304**, which may be air or a hydraulic liquid, may be at or near atmospheric pressure. Pressure at or near atmospheric will be insufficient to overcome the wellbore fluid pressure that is acting on the side of the shifting sleeve **280** that is opposite to the side on which the piston **306** acts. Thus, the shifting sleeve **280** is maintained in the pre-activated position. Referring to **FIG. 9**, once the pin shaft has been axially displaced, the seals **92** no longer seal the annular passage **322**. Instead, the seals **92** form a fluid-tight barrier in an adjacent bore section **330** adjacent to the annular passage **322**.

[0037] Referring to **FIG. 8**, in one mode of use, the firing head **238** is conveyed downhole in the illustrated pre-activated position. In this position, wellbore fluid can flow via the opening **254** into the bore **290** and bore section **302**. One or more passages **340** in the shifting sleeve **280** may provide a fluid connection between the bore **290** and the bore section **302**. As discussed above, the pressure of the fluid in the bore **290** may assist in keeping the shifting sleeve **280** in the pre-activated position, *i.e.*, not blocking the opening **254**.

[0038] For brevity, the various details of the response of the pin assembly **262** to an applied pressure pulse will not be described as the response is generally similar to that described in connection with the **FIG. 2** embodiment. A difference in operation exists after the pin assembly **262** has translated toward and contacted the detonator **40**. At this time, high pressure well fluid resides in the bore section **302**.

[0039] Referring to **FIG. 9**, the well fluid in the bore section **302** flows through the annular passage **322** and via the fluid path **300** into the passage **304**. By acting on the pressure face **308**, the fluid pressure axially displaces the piston(s) **306** toward the shifting sleeve **280**. The contact end **310** of the piston(s) **306** may contact the shifting sleeve **280** at a shoulder **340** or other suitable contact surface of the shifting sleeve **280**. In response to the applied pressure, the shifting sleeve **280** slides along the bore **290** until seated under the opening(s) **254**. When seated, the seals **288** may bracket and form fluid barriers that isolate the bore **264** from the openings(s) **254**. As should be apparent from the above, the bore **264** include in serial alignment, the bore section **290** that generally include the

opening(s) **254**, an bore section **302**, a bore section **324** that includes the annular passage **322**, and a bore section **330** in which the seals **92** may form a seal after activation. In embodiments, a biasing member **400**, such as spring, may be positioned in one or more of the passages **304** to assist in pushing the pistons **306** toward the shifting sleeve **280**.

[0040] Referring to **FIG. 8**, a seal may also be formed that isolates the bore **264** from fluid communication with an adjacent bore **350**, which may be the connector tube bore **50** (**FIG. 1B**). In one embodiment, an upper housing **361** may include an inwardly projecting annular shoulder **363** that acts as a sealing surface. The piston head **268** may include a contact face **366** on which is disposed an annular sealing member **368**. The contact face **366** and the shoulder **363** are generally parallel to one another. Thus, pressing the contact face **366** against the shoulder **363** activates the sealing member **368**, which forms a fluid-tight barrier at the contacting surfaces.

[0041] In embodiments, the seal at the shoulder **363** is directionally sensitive. The biasing member **282** provides a biasing force that urges the piston head **268** to the shoulder **262**. For a seal to be made, the biasing force combined with the fluid pressure in the bore **264** must be greater than the fluid pressure in the adjacent bore **350** in which the annular shoulder **363** is positioned. Specifically, the pressure differential must be sufficiently large to axially displace the piston head **268** toward the shoulder **363** and activate the sealing member **368**. If a pressure differential of sufficient magnitude does not exist, then fluid-tight seal may not be formed. Moreover, if the pressure in the adjacent bore **350** is greater than the pressure in the bore **264** in an amount to overcome the biasing force of the biasing member **282**, then the piston head **268** is displaced away from the shoulder **363**.

[0042] Referring to **FIGS. 1** and **8**, it should be appreciated that the firing head **238** acts as a check valve to provide well control prior to activating the firing head **238**. The face seal **368** on piston head **268** ensures that pressure at or downhole of the firing head **238** will not enter the connector **36**. However, pressure from uphole of the firing head **238** will push the piston head **268** away

from the shoulder **363** and allow fluid to move down the connector **36** and into the firing head **238**. If the system **100** is removed from a live well before activation, the piston head **238** provides well control.

[0043] In the context of the present disclosure, a detonation is a supersonic combustion reaction. Whereas a burn or deflagration is a subsonic combustion reaction. High explosives (RDX, HMX, etc.) will detonate. Low explosives such as propellant will deflagrate. Therefore, when the propellant burns (deflagrates) it creates a subsonic pressure pulse that may be used to propel the piston and generate a pressure pulse through the tubing to activate the next firing head.

[0044] The foregoing description is directed to particular embodiments of the present disclosure for the purpose of illustration and explanation. It will be apparent, however, to one skilled in the art that many modifications and changes to the embodiment set forth above are possible without departing from the scope of the disclosure. It is intended that the following claims be interpreted to embrace all such modifications and changes.

CLAIMS

What is claimed is:

1. A firing head assembly for a well tool operated in a borehole having a borehole fluid, the firing head assembly including:
 - a shaft having a nose and a terminal end, the shaft including a first shoulder and a second shoulder formed between the nose and the terminal end;
 - a piston head slidably mounted on the shaft and positioned between the retaining element and the first shoulder;
 - a biasing member mounted on the shaft and positioned between the piston head and the second shoulder; and
 - a housing having a bore in which the shaft, the piston head, and biasing member are disposed, wherein the housing includes an opening allowing fluid communication between the housing bore and the borehole fluid external to the housing.
2. The firing head of claim 1, wherein the housing bore has a plurality of serially-aligned bore sections, wherein the plurality of bore sections include a first bore section diametrically larger than the piston head, a second bore section that is diametrically smaller than the first bore section, and a third bore section directly radially inward of the housing opening, the second bore section connecting the first bore section with the third bore section.
3. The firing head of claim 2, wherein the piston head hydraulically isolates the first bore section from the third bore section when received in the second bore section.
4. The firing head of claim 2, further comprising at least one frangible member connecting the shaft to the housing, wherein the at least one frangible

member is configured to break only after the piston head enters the second bore section.

5. The firing head of claim 2, wherein the biasing member positions the piston head in the first bore section when the biasing member is in an axially expanded state.

6. The firing head of claim 5, wherein the piston head compresses the biasing member against the second shoulder when in the second bore section.

7. The firing head of claim 1, further comprising a shifting sleeve disposed in a bore section of the housing, a portion of the bore section being radially inward of the housing opening, the shifting sleeve having a first position that does not block the housing opening and a second position wherein the shifting sleeve blocks the housing opening.

8. The firing head of claim 7, wherein the housing includes at least one passage in which a piston is disposed, the piston having a contact end configured to engage the sliding sleeve and a pressure end, the piston shifting the shifting sleeve from the first position to the second position when fluid pressure is applied to the pressure end.

9. The firing head of claim 8, wherein a biasing member is disposed in the at least one passage, the biasing member urging the piston toward the sliding sleeve.

10. The firing head of claim 8, wherein the housing includes a fluid path communicating fluid from the bore section to the passage.

11. The firing head of claim 10, wherein the shaft includes at least one sealing member, the at least one sealing member blocking fluid flow between the bore

section and the at least one passage in the first position and allowing fluid flow between the bore section and the at least one passage in the second position.

12. The firing head of claim 10, wherein the housing includes an inwardly projecting annular shoulder, and the piston head includes a contact face and an annular sealing member disposed on the contact face, the piston head forming a seal with the annular shoulder when a fluid pressure is greater at the housing opening than a bore section in which the annular shoulder is positioned.

10 →

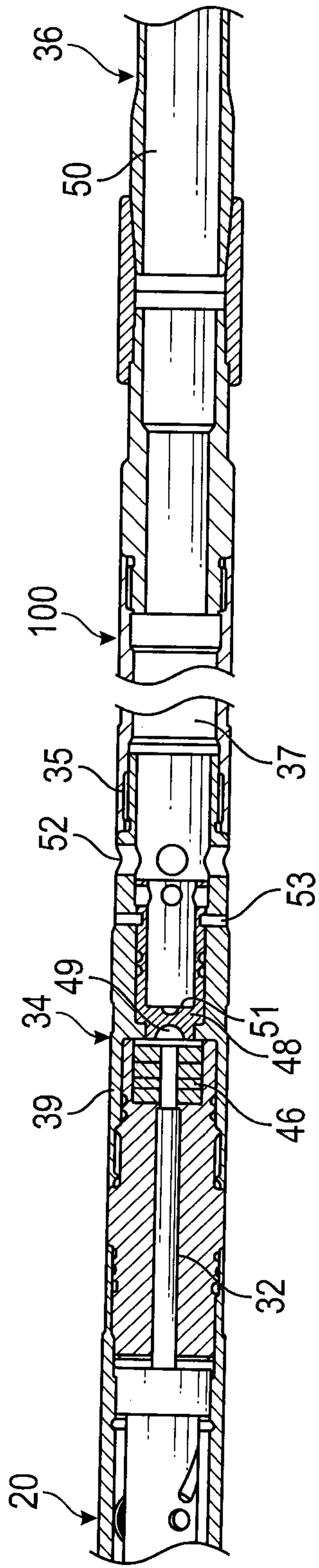

1/7

FIG. 1A

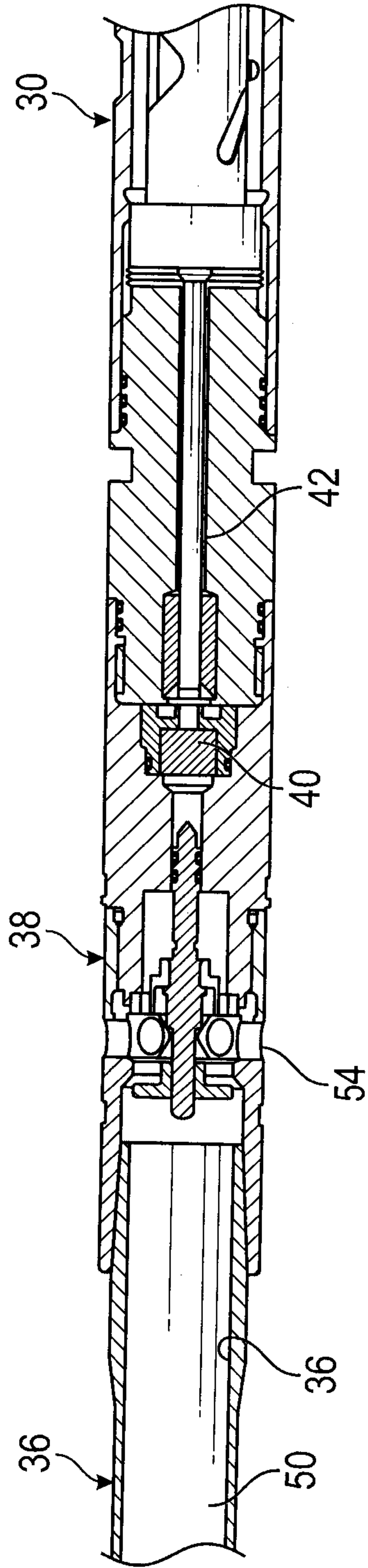

FIG. 1B

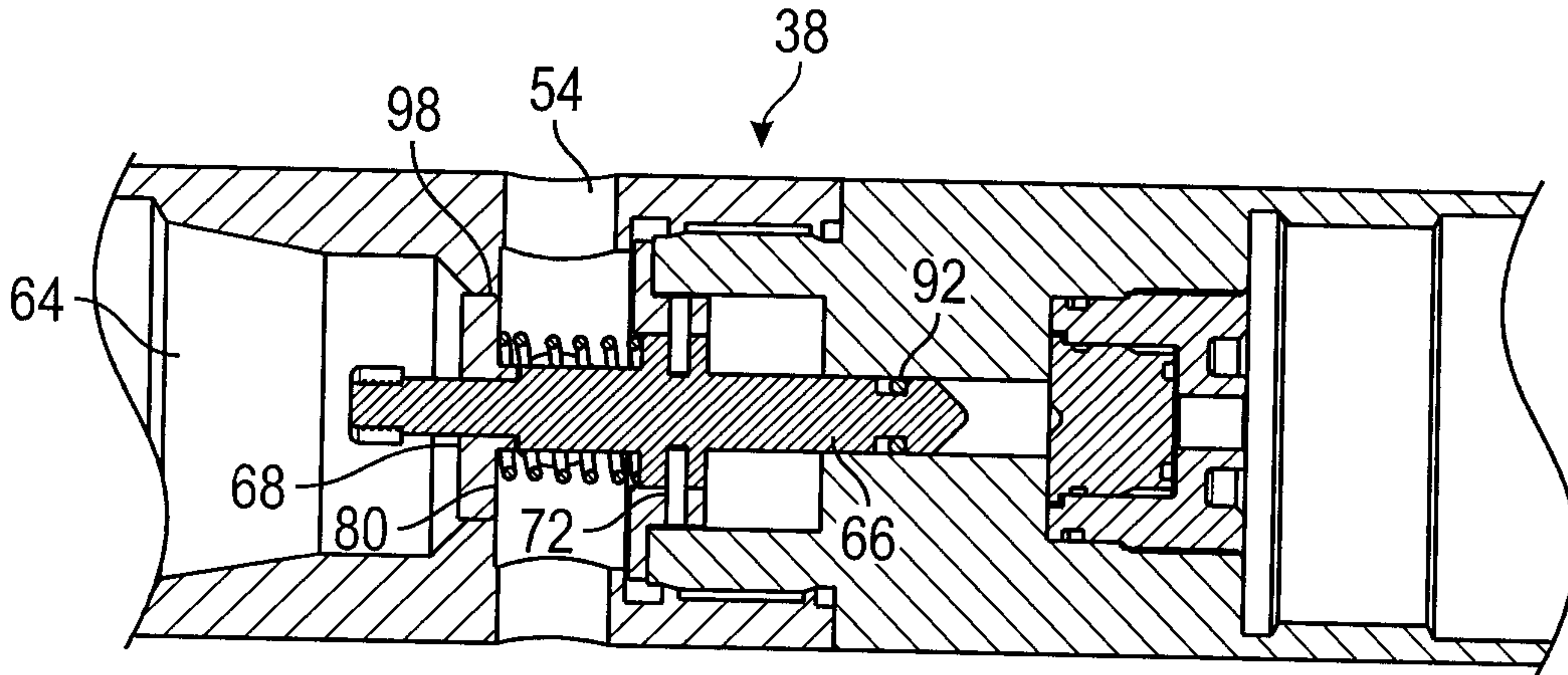

FIG. 3

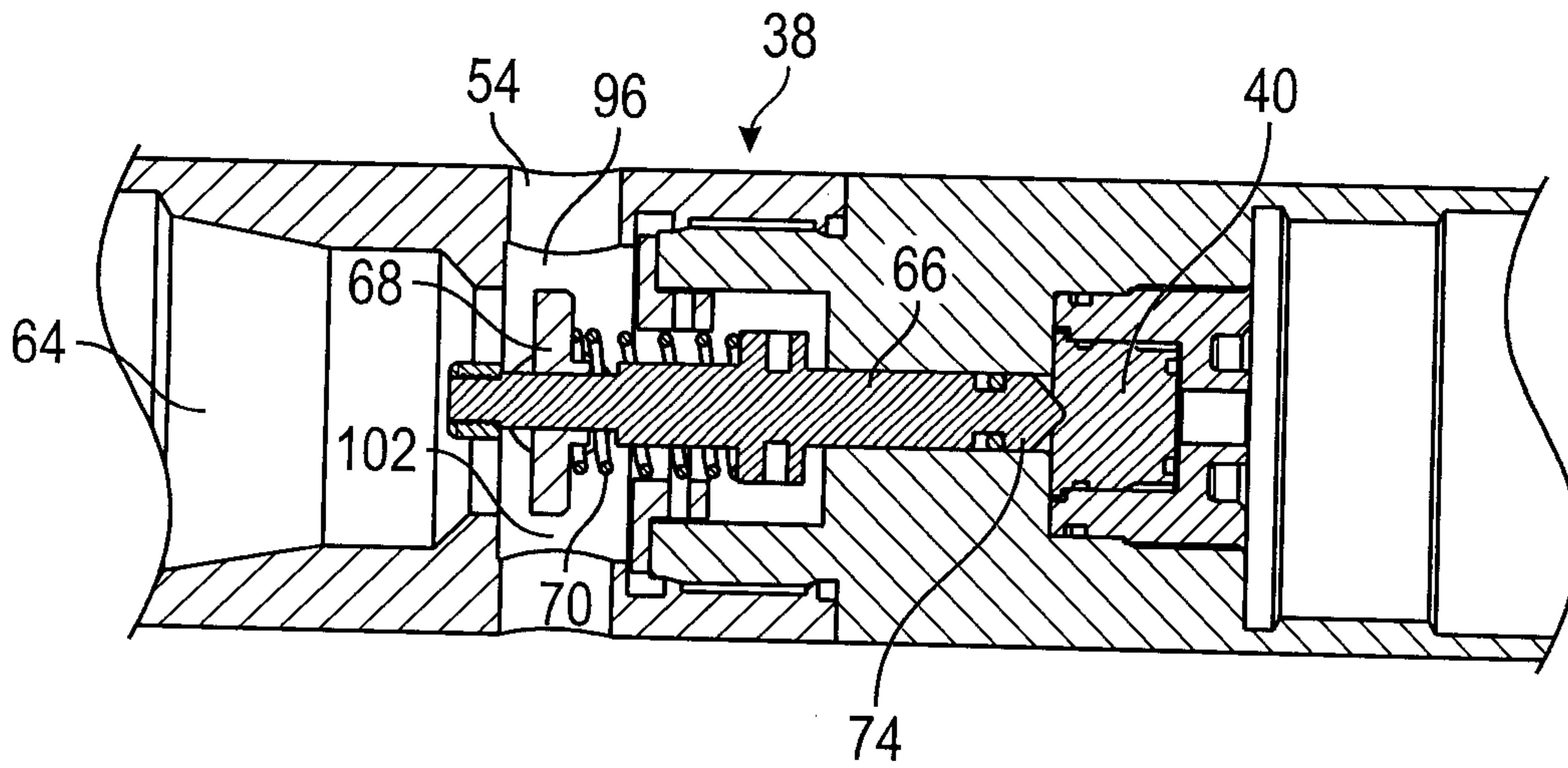

FIG. 4

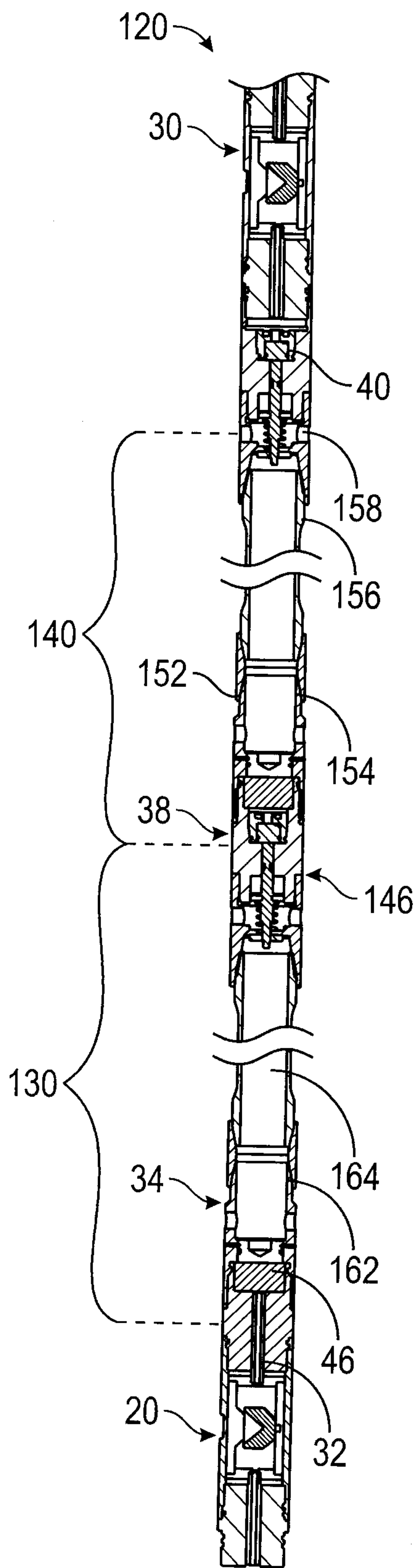

FIG. 5

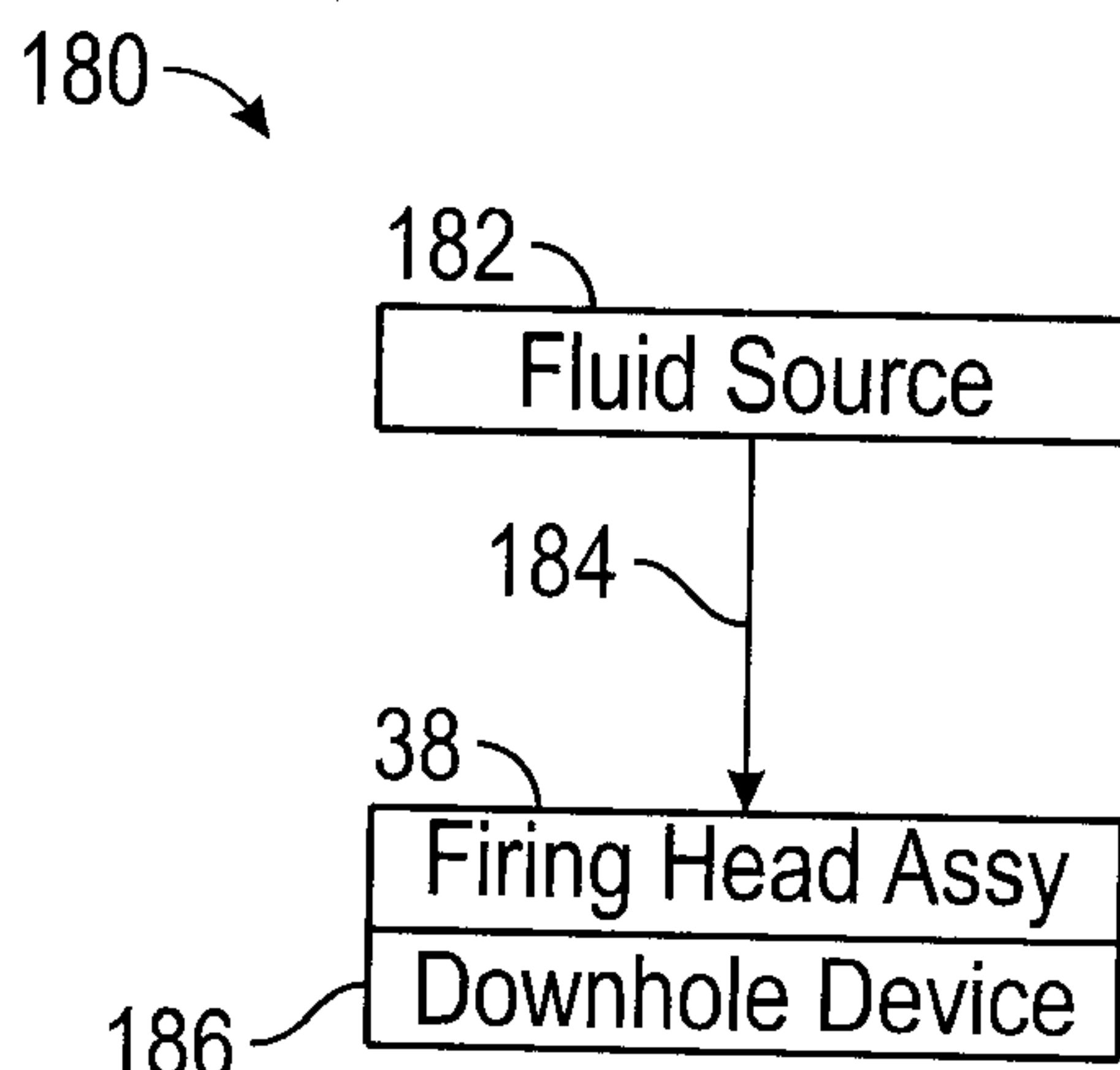

FIG. 6

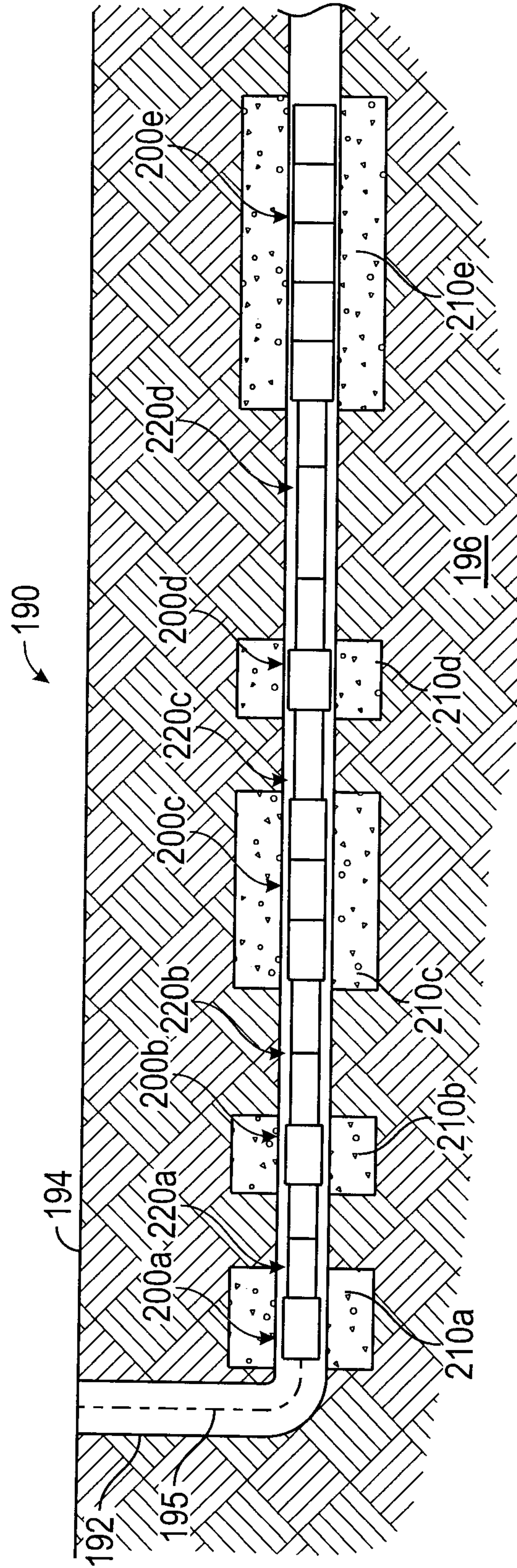

FIG. 7

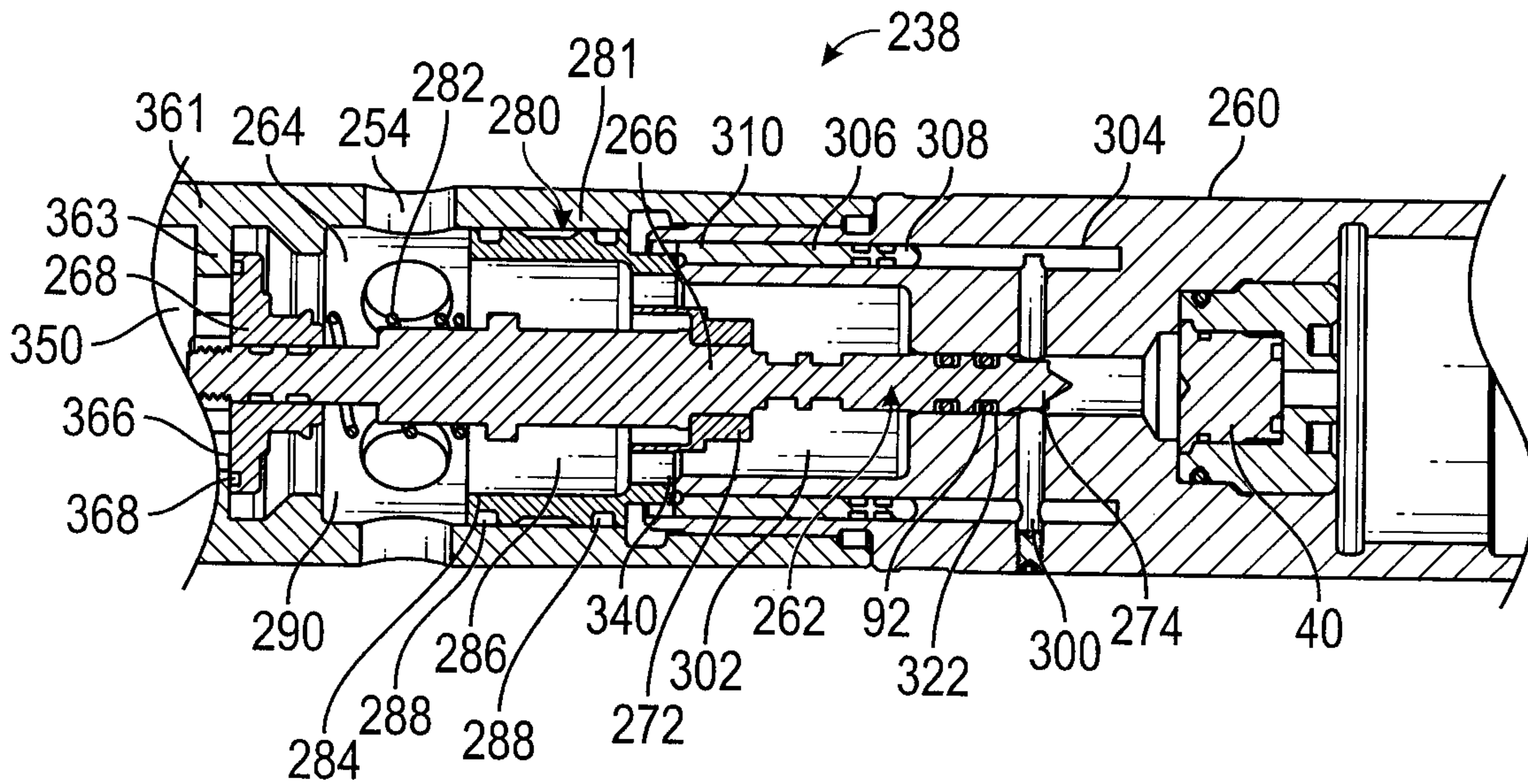

FIG. 8

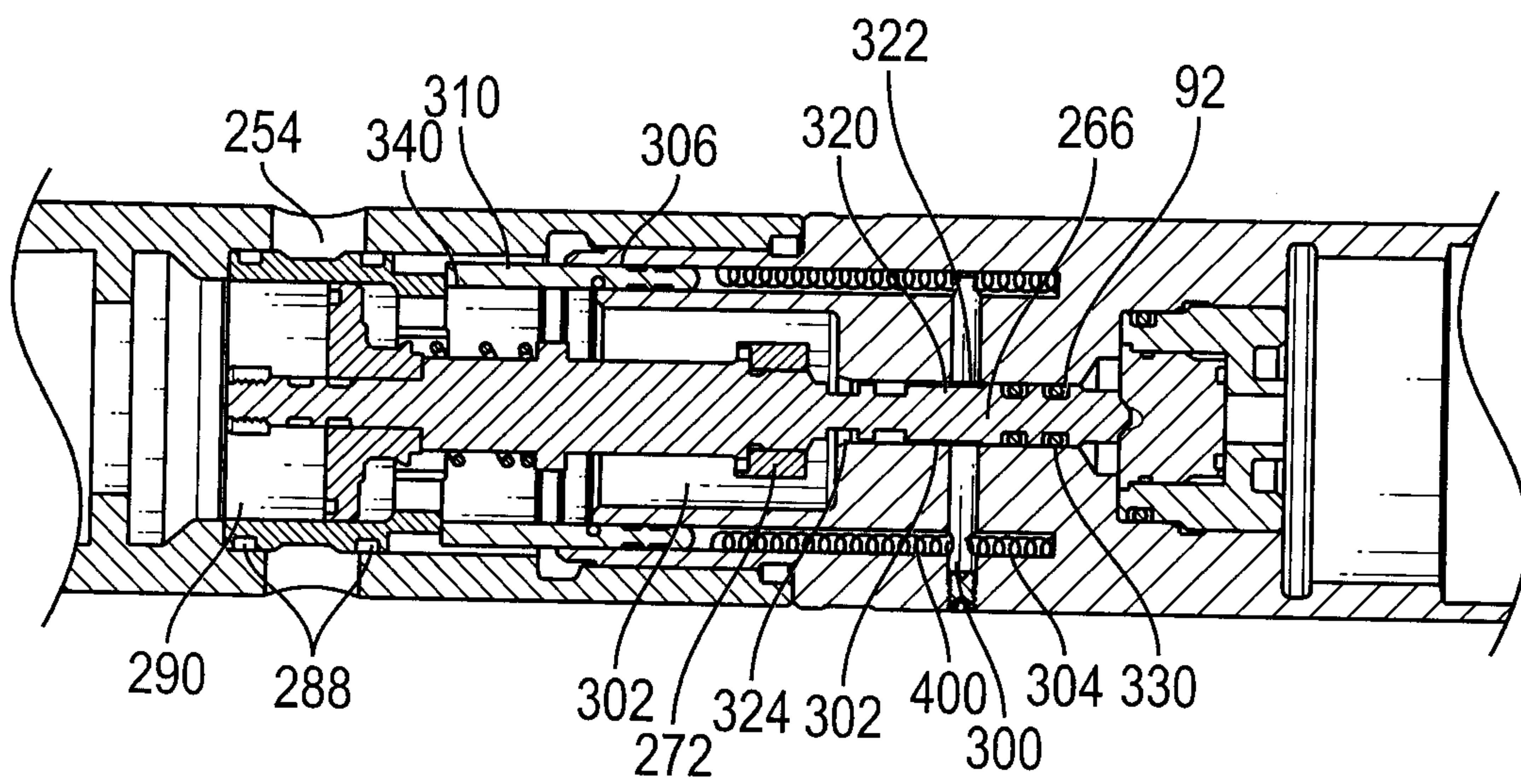
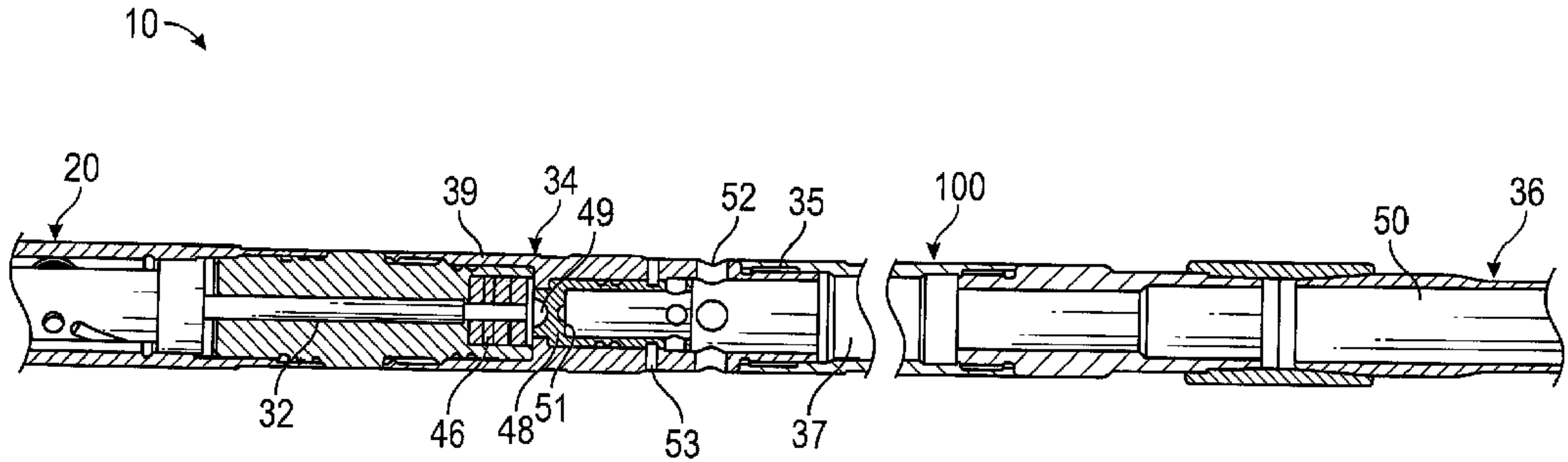

FIG. 9



A