

L. H. BERRY.
GAS GENERATOR.

APPLICATION FILED SEPT. 28, 1910.

1,002,025.

Patented Aug. 29, 1911.

2 SHEETS-SHEET 1.

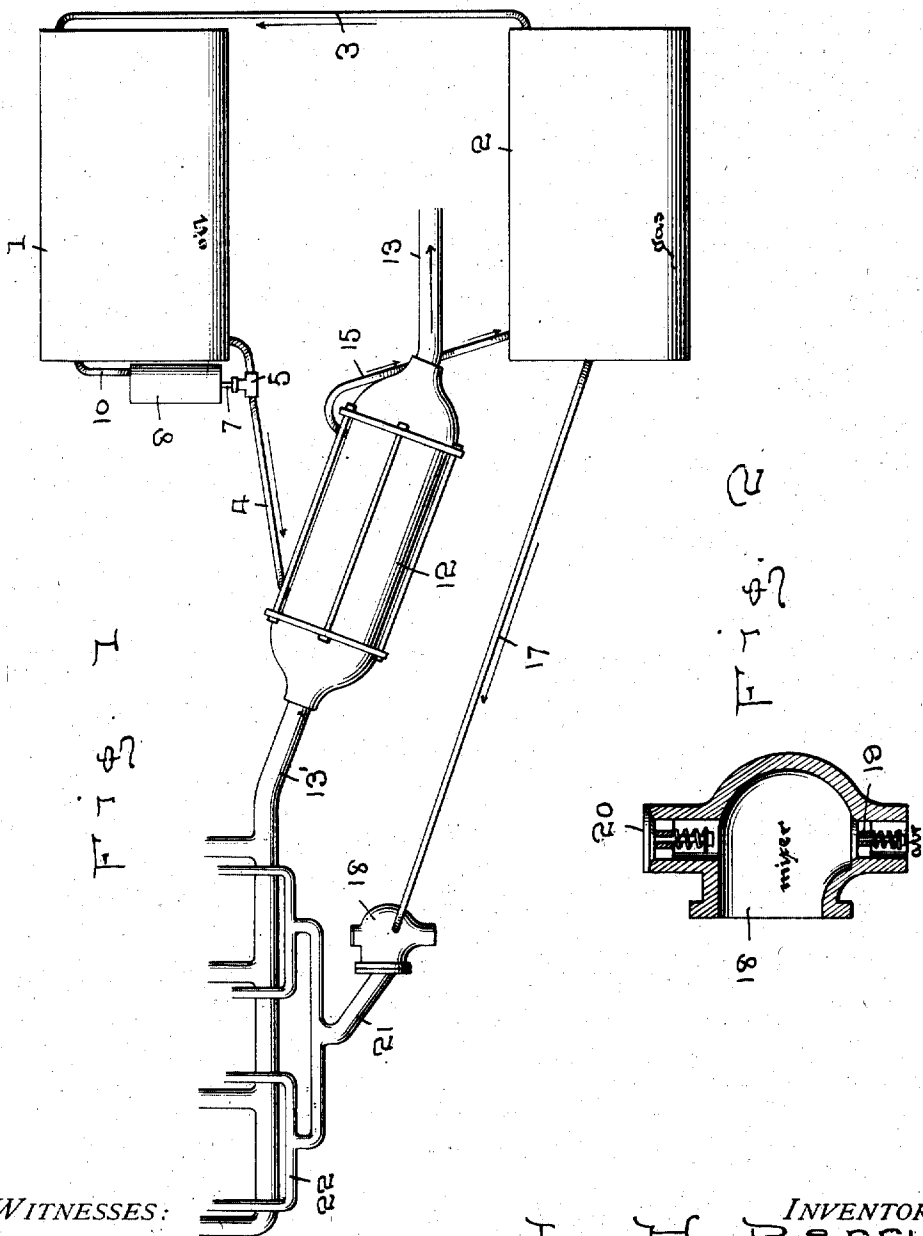

Fig. 1

Fig. 2

WITNESSES:

Thos. W. Riley
M. Newcomb

INVENTOR

L. H. Berry

BY

W. J. FitzGerald & Co.
Attorneys

L. H. BERRY.
GAS GENERATOR.
APPLICATION FILED SEPT. 26, 1910.

1,002,025.

Patented Aug. 29, 1911.

2 SHEETS—SHEET 2.

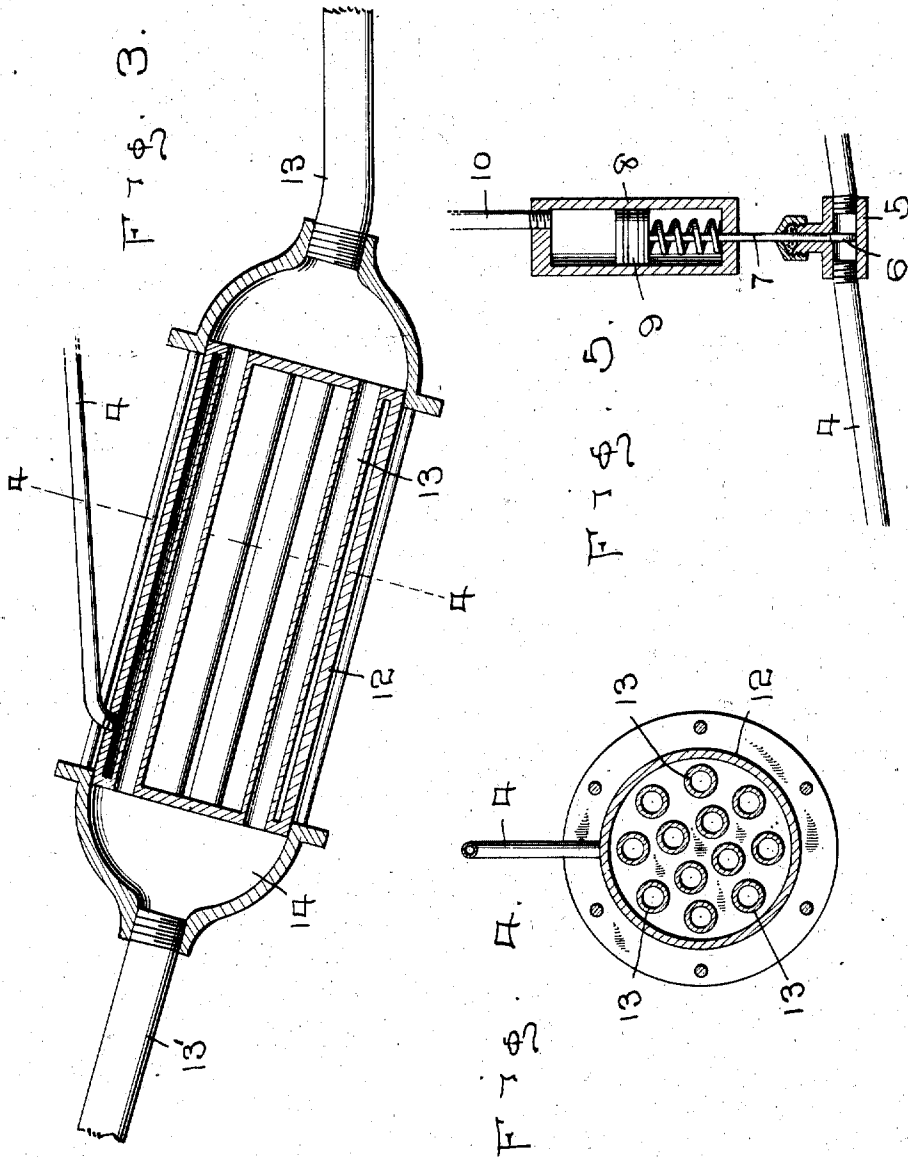

WITNESSES:

Thos. W. Riley
M. Newcomb

INVENTOR
L. H. Berry

BY

W. J. Fitzgerald
Attorney

UNITED STATES PATENT OFFICE.

LEVI H. BERRY, OF PITTSBURG, KANSAS, ASSIGNOR OF ONE-FOURTH TO CORNELIUS E. PIPER, OF PITTSBURG, KANSAS.

GAS-GENERATOR.

1,002,025.

Specification of Letters Patent. Patented Aug. 29, 1911.

Application filed September 26, 1910. Serial No. 583,799.

To all whom it may concern:

Be it known that I, LEVI H. BERRY, a citizen of the United States, residing at Pittsburg, in the county of Crawford and State of Kansas, have invented certain new and useful Improvements in Gas-Generators; and I do hereby declare the following to be a full, clear, and exact description of the invention, such as will enable others skilled in the art to which it appertains to make and use the same.

This invention relates to certain new and useful improvements in gas generators for making gas from kerosene, etc., for engines of the automobile, stationary and marine type, the object being to provide a generator which is so constructed that the oil will be readily converted into gas by the heat from the exhaust of the engine.

Another object of my invention is to provide a mixer in connection with the generator, whereby the required amount of air will be mixed with the gas before it enters the cylinders of the engine.

A still further object of my invention is to provide supply and storage tanks, which are so connected that the pressure within the respective tanks will be equal.

Another object of my invention is to provide a regulator in connection with the feed tank, whereby the control of oil to the generator will be regulated by the pressure within the tank.

With these objects in view, the invention consists in the novel features of construction, combination and arrangement of parts hereinafter fully described and pointed out in the claims.

In the drawing forming a part of this specification: Figure 1 is a diagrammatic view of my improved invention. Fig. 2 is a detail vertical section through the mixer. Fig. 3 is a longitudinal section through the generator. Fig. 4 is a section taken on line 4-4 of Fig. 3, and Fig. 5 is a vertical section through the feed regulator.

In carrying out my improved invention, I employ a feed tank 1 and a storage tank 2, which are connected together by a pipe 3, as clearly shown. Extending from the feed tank 1 is a pipe 4 which is provided with a gate valve casing 5, in which is mounted a gate valve 6 provided with a stem 7 which extends into a cylinder 8, and is provided with a piston 9 which works within the cylinder

and is controlled by the pressure within the feed tank, said cylinder being connected thereto by a pipe 10. A spring is arranged under the piston 9 around the stem 7 in order to resist a certain amount of pressure.

Connected to the supply pipe 4 is a generating cylinder 12 provided with flues 13 through which hot gases from the exhaust pipe 13' are adapted to pass, said cylinder being provided with a head 14 at each end to which the respective ends of the exhaust pipe are connected in such a manner that the oil fed into the cylinder will percolate over the flues which have been heated by the exhaust gases in such a manner that the oil will be converted into gas, which will pass out of a pipe 15 into the storage tank 2 which is of such a size that the same will hold a sufficient quantity of gas to start the engine in order that the heat from the engine will be able to continue the generation of gas for running the same. The exhaust pipe 13 is connected by branch pipes to the respective cylinders of a gas engine (not shown), and is of the ordinary construction.

Extending from the storage tank 2 is a supply pipe 17 which extends to a mixer 18 which is provided with an air inlet valve 19 and an exhaust valve 20 for relieving the same of over-pressure in case that the engine back fires. Extending from the mixer 18 is a pipe 21 which is provided with branch pipes 22 connecting the same to the respective cylinders of the engines, whereby the gas generated from the generator and stored into the tank 2 will be conveyed through the mixer where air will be mixed with the same and delivered to the respective cylinders of the engine, said tank holding a sufficient quantity of gas to run the engine until the generator has been heated in order to generate a new supply of gas.

From the foregoing description, it will be seen that I have provided a gas generator for gas engines of all kinds which is so constructed that gas will be generated by the heat from the exhaust. It will also be seen that I have provided a storage tank in connection with the generator in which gas can be stored in order to start the engine.

What I claim is:

1. A gas generator for explosive engines, comprising a cylinder provided with a plurality of flues through which the exhaust combustion gases are adapted to pass, an oil

supply pipe connected to said cylinder, a gas outlet pipe connected to said cylinder, tanks connected to the respective supply and outlet pipes, and a pipe connecting said tanks.

2. A gas generator for explosive engines, comprising a compartment provided with a plurality of flues through which the exhaust combustion gases are adapted to pass, a fuel supply pipe connected to said compartment, a gas outlet pipe connected to said compartment, tanks connected to the respective supply and outlet pipes, a pipe connecting said tanks, and means operated by the pressure in said tanks to regulate the flow of fuel in said supply pipe.

3. A gas generator for explosive engines, comprising the combination with a compartment having passages therethrough for the exhaust combustion gases, of an oil supply pipe connected to said compartment, a gas outlet pipe connected to the compartment, tanks connected to the respective sup-

ply and outlet pipes, a pipe connecting said tanks, a valve in said fuel supply pipe, and a plunger connected to said valve and adapted to be operated by the pressure in said tanks.

4. In a gas generator for explosive engines, the combination with a gas generating compartment, supply and outlet pipes connected to said compartment, supply and storage tanks connected to said pipes, and a pipe connecting said tanks; of a regulator for said generator, comprising a cylinder, said cylinder being in communication with said supply tank, a piston in said cylinder, and a valve interposed in said supply pipe and connected to said piston.

In testimony whereof I have signed my name to this specification in the presence of two subscribing witnesses.

LEVI H. BERRY.

Witnesses:

THEODORE C. BURWELL,
CORNELIUS E. PIPER.