

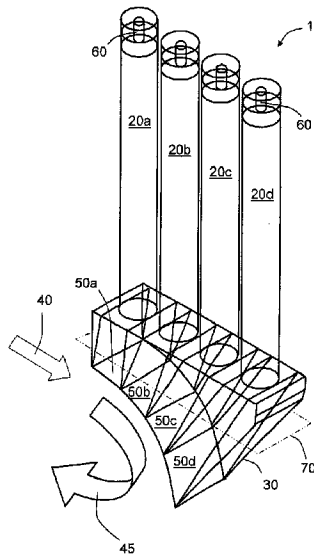

(86) **Date de dépôt PCT/PCT Filing Date:** 2013/07/31  
 (87) **Date publication PCT/PCT Publication Date:** 2014/02/13  
 (45) **Date de délivrance/Issue Date:** 2020/07/21  
 (85) **Entrée phase nationale/National Entry:** 2015/02/04  
 (86) **N° demande PCT/PCT Application No.:** EP 2013/002266  
 (87) **N° publication PCT/PCT Publication No.:** 2014/023401  
 (30) **Priorités/Priorities:** 2012/08/04 (NO NO20120871);  
 2012/08/04 (GB GB1213884.8)

(51) **Cl.Int./Int.Cl. F03B 13/14** (2006.01),  
**E02B 9/08** (2006.01), **F03B 13/24** (2006.01)  
 (72) **Inventeur/Inventor:**  
 SOLHEIM, GEIR ARNE, NO  
 (73) **Propriétaire/Owner:**  
 HAVKRAFT AS, NO  
 (74) **Agent:** GASTLE AND ASSOCIATES

(54) **Titre : CONVERTISSEUR D'ENERGIE DES VAGUES A L'AIDE DE COLONNES**  
 (54) **Title: WAVE ENERGY CONVERTER WITH COLUMNS**



(57) **Abrégé/Abstract:**

A wave energy converter (10) is operable to convert energy conveyed in ocean waves propagating in a wave propagation direction (40) in an ocean environment and received at the converter (10) into generated power. The converter (10) includes a plurality of columns (20) which are in fluidic communication via corresponding ports (50) to the ocean waves received at the converter (10). The ports (50) are arranged substantially in series along the wave propagation direction (40), and the ports (50) are of progressively greater depth into the ocean environment along the wave propagation direction (40) so as to cause the ocean waves to propagate in a downwardly-directed manner (45) when received at the ports (50). The plurality of columns (20) are arranged so that their elongate axes are substantially aligned along a first direction, and that the ports (50) have corresponding port angles (T) relative to the first direction which are progressively larger as the ports (50) are of progressively greater depth. Alternatively, the plurality of columns (20) are arranged so that their elongate axes are substantially aligned along a first direction, and that the ports (50) have corresponding port angles (T) relative to the first direction which are progressively smaller as the ports (50) are of progressively greater depth.

(12) INTERNATIONAL APPLICATION PUBLISHED UNDER THE PATENT COOPERATION TREATY (PCT)

(19) World Intellectual Property  
Organization  
International Bureau(10) International Publication Number  
**WO 2014/023401 A3**(43) International Publication Date  
13 February 2014 (13.02.2014)

## (51) International Patent Classification:

F03B 13/14 (2006.01) E02B 9/08 (2006.01)  
F03B 13/24 (2006.01)

## (21) International Application Number:

PCT/EP2013/002266

## (22) International Filing Date:

31 July 2013 (31.07.2013)

## (25) Filing Language:

English

## (26) Publication Language:

English

## (30) Priority Data:

GB1213884.8 4 August 2012 (04.08.2012) GB  
NO20120871 4 August 2012 (04.08.2012) NO

(71) Applicant: HAVKRAFT AS [NO/NO]; P.O. Box 1065,  
N-6704 Deknepollen (NO).(72) Inventor: GEIR, Arne, Solheim; PO Box 1065, N-6704  
Deknepollen (NO).(74) Agent: NORRIS, Timothy, Sweyn; Basck IPR LTD., 9  
Meadowford, Newport, Saffron Walden, Essex CB11 3QL  
(GB).(81) Designated States (unless otherwise indicated, for every  
kind of national protection available): AE, AG, AL, AM,  
AO, AT, AU, AZ, BA, BB, BG, BH, BN, BR, BW, BY,  
BZ, CA, CH, CL, CN, CO, CR, CU, CZ, DE, DK, DM,  
DO, DZ, EC, EE, EG, ES, FI, GB, GD, GE, GH, GM, GT,  
HN, HR, HU, ID, IL, IN, IS, JP, KE, KG, KN, KP, KR,  
KZ, LA, LC, LK, LR, LS, LT, LU, LY, MA, MD, ME,  
MG, MK, MN, MW, MX, MY, MZ, NA, NG, NI, NO, NZ,  
OM, PA, PE, PG, PH, PL, PT, QA, RO, RS, RU, RW, SC,  
SD, SE, SG, SK, SL, SM, ST, SV, SY, TH, TJ, TM, TN,  
TR, TT, TZ, UA, UG, US, UZ, VC, VN, ZA, ZM, ZW.(84) Designated States (unless otherwise indicated, for every  
kind of regional protection available): ARIPO (BW, GH,  
GM, KE, LR, LS, MW, MZ, NA, RW, SD, SL, SZ, TZ,  
UG, ZM, ZW), Eurasian (AM, AZ, BY, KG, KZ, RU, TJ,  
TM), European (AL, AT, BE, BG, CH, CY, CZ, DE, DK,  
EE, ES, FI, FR, GB, GR, HR, HU, IE, IS, IT, LT, LU, LV,  
MC, MK, MT, NL, NO, PL, PT, RO, RS, SE, SI, SK, SM,

[Continued on next page]

## (54) Title: WAVE ENERGY CONVERTER

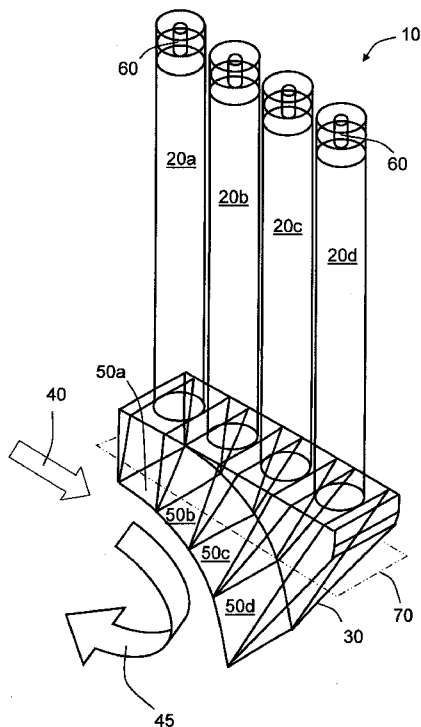

FIG. 1

(57) Abstract: A wave energy converter (10) is operable to convert energy conveyed in ocean waves propagating in a wave propagation direction (40) in an ocean environment and received at the converter (10) into generated power. The converter (10) includes a plurality of columns (20) which are in fluidic communication via corresponding ports (50) to the ocean waves received at the converter (10). The ports (50) are arranged substantially in series along the wave propagation direction (40), and the ports (50) are of progressively greater depth into the ocean environment along the wave propagation direction (40) so as to cause the ocean waves to propagate in a downwardly-directed manner (45) when received at the ports (50). The plurality of columns (20) are arranged so that that their elongate axes are substantially aligned along a first direction, and that the ports (50) have corresponding port angles ( $\Theta$ ) relative to the first direction which are progressively larger as the ports (50) are of progressively greater depth. Alternatively, the plurality of columns (20) are arranged so that that their elongate axes are substantially aligned along a first direction, and that the ports (50) have corresponding port angles ( $\Theta$ ) relative to the first direction which are progressively smaller as the ports (50) are of progressively greater depth.

**WO 2014/023401 A3** 

TR), OAPI (BF, BJ, CF, CG, CI, CM, GA, GN, GQ, GW, KM, ML, MR, NE, SN, TD, TG).

**Published:**

— *with international search report (Art. 21(3))*

**Declarations under Rule 4.17:**

— *as to applicant's entitlement to apply for and be granted a patent (Rule 4.17(ii))*

— *before the expiration of the time limit for amending the claims and to be republished in the event of receipt of amendments (Rule 48.2(h))*

— *as to the applicant's entitlement to claim the priority of the earlier application (Rule 4.17(iii))*

**(88) Date of publication of the international search report:**

10 April 2014

— *of inventorship (Rule 4.17(iv))*

## **WAVE ENERGY CONVERTER WITH COLUMNS**

### **Field of the invention**

5 The present invention relates to wave energy converters, for example to wave energy converters for generating renewable energy or for absorbing wave energy for providing protection against Ocean waves, for example for providing protection for floating structures and/or for reducing coastal erosion. Moreover, the present invention concerns methods of generating  
10 renewable energy using aforementioned wave energy converters. Furthermore, the present invention concerns methods of absorbing wave energy using aforementioned wave energy converters, for example for providing protection for floating structures and/or for reducing coastal erosion. Additionally, the present Invention concerns component parts for  
15 constructing aforementioned wave energy converters. Additionally, the present Invention concerns systems for generating power from ocean waves, wherein the systems include a plurality of aforesaid wave energy converters. Yet additionally, the present invention concerns systems for absorbing wave energy for providing protection against ocean waves,  
20 wherein the systems include a plurality of aforesaid wave energy converters.

### **Background of the invention**

Wave energy converters are known in the art and employ a variety of  
25 wave energy conversion mechanisms. However, unlike offshore wind turbines, ocean wave energy converters have not hitherto been deployed in large numbers for providing electrical power to electrical supply networks. A contemporary challenge is to implement aforesaid ocean wave energy converters in a cost-effective manner, whilst ensuring that  
30 they convert ocean wave energy efficiently to electrical power and also survive severe weather conditions which are occasionally encountered offshore. The challenge thus has associated constraints which can be

mutually opposing, for example a robust design of ocean wave converter is potentially more costly to manufacture and deploy in comparison to a less-robust structure.

- 5 A robust and efficient wave energy converter is described in a published international PCT patent application no. WO2011/162615A2 (PCT/NO2011/000175, "*Ocean Wave Energy System*", Havkraft AS, Geir Solheim). The wave energy converter is implemented as an ocean wave energy system for generating power from ocean waves, wherein the system
- 10 includes a platform supporting an array of hollow columns whose respective lower ends are in fluidic communication with ocean waves and whose respective upper ends are in air communication with a turbine arrangement such that wave motion occurring at the lower ends is operable to cause air movement within the columns for propelling the
- 15 turbine arrangement to generate power output. The system further includes one or more position-adjustable and/or angle-adjustable submerged structures near the lower ends of the columns for forming ocean wave propagating in operation towards the lower ends of the columns to couple the waves in a controllable manner into the hollow
- 20 columns.

In the aforesaid published PCT application no. WO2011/162615A2, there is provided a comprehensive overview of wave energy theory. Ocean waves are surface waves substantially at an interface between two fluids,

25 namely ocean water and air. The surface waves propagate substantially within a plane of the interface and are susceptible to being refracted, reflected, transmitted and absorbed at any objects intersecting substantially with the plane of the interface. For the surface waves to be absorbed effectively, the objects must be wave impedance matched to an

30 impedance of the surface waves. When the objects are of a physical size comparable to a wavelength of the surface waves, designing the objects to provide an effective wave impedance match is a complex task,

especially when the surface waves in practice have a varying wavelength depending upon ocean weather conditions. In addition, the objects need to be designed to withstand severe storm conditions and also be substantially free of cavitation effects when large amounts of wave energy are being absorbed by the objects. The aforesaid published PCT application describes a wave energy converter which is capable of providing efficient absorption of ocean waves. Although there are many similarities between electromagnetic wave propagation and ocean wave propagation, there are major differences on account of ocean waves having mass and being subject to fluid flow effects.

However, there arises a need to implement a wave energy converter which is especially efficient at absorbing ocean wave energy whilst also being robust in operation, and cost effective to manufacture. For example, it is desirable that the wave energy converter is manufactured in such a manner which is convenient for contemporary shipyards.

### **Summary of the Invention**

The present invention seeks to provide an improved wave energy converter which is more efficient in operation, more robust and more efficient in its use of construction materials.

According to a first aspect of the present invention, there is provided a wave energy converter for converting in operation energy conveyed in ocean waves propagating in a wave propagation direction in an ocean environment and received at the converter into generated power, comprising a plurality of columns which are in fluidic communication via corresponding ports to the ocean waves received at the converter, wherein the ports are arranged substantially in series along the wave propagation direction, and wherein the ports are of progressively greater depth into the ocean environment along the wave propagation direction so as to cause a first component of the ocean waves to propagate in a

downward direction and a second component of the ocean waves to propagate into the ports to couple energy thereto, and the plurality of columns are arranged with elongate axes substantially aligned along a first direction, and such that the ports have corresponding port angles  
5 relative to the first direction which are progressively larger or smaller as the ports are of progressively greater depth.

The invention is of advantage in that the disposition of the plurality of ports to create a downwardly-directed vortex provides for more efficient  
10 wave energy adsorption.

Optionally, in the wave energy converter, the plurality of columns are arranged so that that their elongate axes are substantially aligned along a first direction, and that the ports have corresponding port angles ( $\Theta$ )  
15 relative to the first direction which are progressively larger as the ports are of progressively greater depth. More optionally, in the wave energy converter, the first direction is substantially a vertical direction when the converter is in operation.

20 Optionally, in the wave energy converter, the plurality of columns are arranged so that that their elongate axes are substantially aligned along a first direction, and that the ports have corresponding port angles ( $\Theta$ ) relative to the first direction which are progressively smaller as the ports are of progressively greater depth.

25 Optionally, in the wave energy converter, the ports have an elliptical, round or rectilinear cross-section.

30 Optionally, in the wave energy converter, the plurality of columns are operable to couple to the ocean waves received at the ports in a resonant manner.

Optionally, in the wave energy converter, the columns include corresponding energy pickoff devices at upper regions thereof and/or at lower regions thereof and/or in ports thereof. More optionally, the energy pickoff devices are coupled to a common turbine facility; alternatively, 5 each energy pickoff device functions as an autonomous energy extraction element, for example as a Wells-type turbine mounted at an upper portion of each column.

Optionally, each converter includes in a range of 2 to 10 columns and 10 associated ports arranged in series. More optionally, each converter includes in a range of 3 to 8 columns.

Optionally, the wave energy converter includes one or more submerged wave reflectors in a vicinity of the ports of the converter for reflecting the 15 ocean waves more efficiently into the ports. More optionally, the wave energy converter includes a mechanism for adjusting a spatial position of the one or more submerged wave reflectors relative to the ports for tuning the converter for more optimally converting energy present in the ocean waves.

20 According to a second aspect of the invention, there is provided a wave energy system including a platform defining a peripheral edge thereto, characterized in that a plurality of wave energy converters pursuant to the first aspect of the invention are mounted substantially around at least 25 a portion of the peripheral edge to receive ocean waves propagating towards the system at the converters.

Optionally, in the wave energy system, the platform is provided with one or more peripheral lobes around which the plurality of wave energy 30 converters are disposed.

Optionally, the wave energy system is implemented such that the platform has a triangular, round or polygonal form.

- 5    Optionally, the wave energy system is implemented such that the platform comprises a plurality of polygonal modules which are mutually coupled together to form the platform. More optionally, the wave energy system is implemented such that the plurality of polygonal modules are of mutually similar form.

10

Optionally, the wave energy system is implemented such that the platform is arranged to support a Thorium nuclear reactor apparatus, and that the plurality of wave energy converters are operable to protect the Thorium nuclear reactor apparatus from damage from ocean waves.

15

Optionally, the wave energy system is implemented such that the platform is operable to support one or more buildings. More optionally, the one or more buildings are for one or more of: floating hospitals, residential facilities, hotels, prisons, offshore manufacturing, offshore servicing for oil and gas discovery and production systems, for electrical power distribution offshore.

20

According to a third aspect of the invention, there is provided a method of converting energy conveyed in ocean waves propagating in a wave propagation direction in an ocean environment when received at a wave energy converter to generate power, comprising:

25

- (a)    arranging for the converter to include a plurality of columns which are in fluidic communication via corresponding ports to the ocean waves received at the converter;
- 30    (b)    arranging for the ports to be substantially in series along the wave propagation direction; and

(c) arranging for the ports to be of progressively greater depth into the ocean environment along the wave propagation direction so as to cause a first component of the ocean waves to propagate in a downward direction and a second component of the ocean waves to propagate into the ports to couple energy thereto, 5 wherein said method includes arranging the plurality of columns with elongate axes substantially aligned along a first direction such that the ports have corresponding port angles relative to the first direction which are progressively larger or smaller as the ports are 10 of progressively greater depth.

Optionally, the method includes arranging the plurality of columns so that that their elongate axes are substantially aligned along a first direction, and that the ports have corresponding port angles ( $\Theta$ ) relative to the first 15 direction which are progressively larger as the ports are of progressively greater depth.

Optionally, the method includes arranging the plurality of columns so that that their elongate axes are substantially aligned along a first direction, 20 and that the ports have corresponding port angles ( $\Theta$ ) relative to the first direction which are progressively smaller as the ports are of progressively greater depth.

It will be appreciated that features of the invention are susceptible to 25 being combined in various combinations without departing from the scope of the invention as defined by the appended claims.

### **Description of the diagrams**

Embodiments of the present invention will now be described, by way of 30 example only, with reference to the following diagrams wherein:

FIG. 1 Is an illustration of an embodiment of a wave energy converter pursuant to the present invention, wherein elongate axes of the

ports of the wave energy converter become of progressively shallower angle relative to an ocean surface as the ports are disposed deeper into the ocean;

5 FIG. 2 Is a schematic side view of the wave energy converter of FIG. 1;

FIG. 3A is an illustration of an alternative implementation of a portion of the wave energy converter of FIG. 1, wherein the wave energy converter has a tapered form;

10 FIG. 3B Is an illustration of an alternative implementation of a wave energy converter pursuant to the present invention, wherein elongate axes of the ports of the wave energy converter become of progressively steeper angle relative to an ocean surface as the ports are disposed deeper into the ocean;

15 FIG. 4 is an illustration of an ocean wave energy system including a peripheral arrangement of wave energy converters pursuant to at least one of FIG. 1 to FIG. 3B;

FIG. 5 is an illustration of an above-sea-level portion of an ocean wave energy system including a peripheral arrangement of wave energy converters pursuant to at least one of FIG. 1 to FIG. 3B;

20 FIG. 6 is an illustration of an underside portion of the ocean wave energy system of FIG. 5;

FIG. 7 is an illustration of a frame of an alternative ocean wave energy system including a peripheral arrangement of wave energy converters pursuant to at least one of FIG. 1 to FIG. 3B;

25 FIG. 8 is an illustration of an underside of the alternative ocean wave energy system of FIG. 7 with its wave energy converters shown installed into position;

30 FIG. 9 is an illustration of an upper side of the alternative ocean wave energy system of FIG. 7 with its wave energy converters shown installed into position;

FIG. 10 is an illustration of an alternative ocean wave energy system including a single linear array of Wave energy converters

deposed upon a platform having four peripheral support cylindrical towers;

FIG. 11 is an illustration of the ocean wave energy system as illustrated in FIG. 10 with service ships moored alongside to provide an indication of dimensions of the system;

FIG. 12 is a plan view illustration of the ocean wave energy system of FIG. 4 equipped with a substantially central service building, wherein the plan view provides an illustration of a configuration of hexagonal modules assembled together to provide a platform for the system; and

FIG. 13 is an illustration of an array of wave energy converters provided with corresponding wave energy reflectors near ports of the converters for improving their energy conversion efficiency.

In the accompanying diagrams, an underlined number is employed to represent an item over which the underlined number is positioned or an item to which the underlined number is adjacent. A non-underlined number relates to an item identified by a line linking the non-underlined number to the item. When a number is non-underlined and accompanied by an associated arrow, the non-underlined number is used to identify a general item at which the arrow is pointing.

### **Description of embodiments of the invention**

Referring to FIG. 1, the present invention concerns in overview a wave energy converter **10** including a plurality of substantially enclosed air columns **20a, 20b, 20c, 20d** coupled via a port arrangement **30** into fluidic communication with ocean waves propagating in an ocean in a horizontal wave propagation direction substantially as denoted by an arrow **40**, for example a forward direction. The port arrangement **30** includes port channels **50a, 50b, 50c, 50d** coupled at their upper ends to the air columns **20a, 20b, 20c, 20d** respectively and also at their lower ends to the ocean waves, wherein the port channels **50a, 50b,**

**50c, 50d** have their lower ends at progressively greater depths along the forward direction defined by the arrow **40**, and have their elongate axis orientation angles at progressively shallower angles along the forward direction defined by the arrow **40** relative to a surface of the ocean; alternatively defined, the port channels **50a, 50b, 50c, 50d** have their lower ends at progressively greater depths along the forward direction defined by the arrow **40**, and have their elongate axis orientation angles at progressively greater angles  $\Theta$  along the forward direction defined by the arrow **40** relative to a substantially elongate vertical axis of the air columns **20a, 20b, 20c, 20d** as illustrated in FIG. 2. Optionally, the air columns **20a, 20b, 20c, 20d** are operated with their respective elongate axes disposed in substantially a vertical orientation. Optionally, an energy pickoff device **60**, for example an air-propelled Wells-type turbine, is included at an upper end of each air column **20a, 20b, 20c, 20d**, namely remote from the lower ends of the port channels **50a, 50b, 50c, 50d** which are directly in communication with the ocean waves. Alternatively, or additionally, the energy pickoff devices **60** are implemented as one or more open hydro-turbines which are operable to be in direct contact with ocean waves at a lower portion of the air columns **20a, 20b, 20c, 20d**, and/or their associated port channels **50a, 50b, 50c, 50d**; optionally, the hydro-turbines disposed towards a bottom region of the air columns **20a, 20b, 20c, 20d**, and/or their associated port channels **50a, 50b, 50c, 50d** are edge-supported to render them exceptionally robust to the forces of ocean waves received thereat in adverse weather conditions. Such a disposition of the lower ends of the port channels **50a, 50b, 50c, 50d** results in the ocean waves being progressively decelerated and efficiently absorbed at the converter **10** to generate corresponding energy at the energy pickoff devices **60** at the upper ends of the air columns **20a, 20b, 20c, 20d** as a first component of the ocean waves is forced to exhibit a downwardly directed motion denoted by **45**, whereas a second component of the ocean waves coupled into the port channels **50a, 50b, 50c, 50d**; the downwardly directed motion can be considered to be a

form of "vortex" formation, although a majority of flow associated with the ocean waves is coupled into the port channels **50a, 50b, 50c, 50d**. The port arrangement **30** is implemented to provide an optimal absorption of ocean wave energy, whilst substantially avoiding transmission or reflection of wave energy, and whilst being of a general compact size and therefore efficient in use of construction materials. Beneficially, the converter **10** is operable to absorb efficiently both potential energy and kinetic energy of fluid mass associated with the ocean waves to provide an enhanced degree of energy conversion within the converter **10**, for example in excess of 30% of ocean wave kinetic and potential energy to electrical energy output at the energy pickoff devices **60**, more preferable in excess of 50% of ocean wave kinetic and potential energy received at the converter **10**.

The port channels **50a, 50b, 50c, 50d** together with their associated air columns **20a, 20b, 20c, 20d** and energy pickoff devices **60** are operable to function at relatively low pressures excursions so that heating effects associated with air being compressed in the columns **20a, 20b, 20c, 20d** is reduced so as to provide for greater energy conversion efficiency. Beneficially, the energy pickoff devices **60** are operable to function with relatively small pressure differences thereacross, for example by employing large diameter turbines fabricated from light materials, for example reinforced Carbon fibre, to keep their mass low. By "*relatively low pressure*" is meant in a range of 100's of Pascals to a few 1000's of Pascals.

The port channels **50a, 50b, 50c, 50d** together with their associated air columns **20a, 20b, 20c, 20d** are beneficially arranged to operate in a resonant mode, for example by carefully controlling an amount of energy pickoff at the energy pickoff devices **60**, so as to obtain a desired degree of damping, namely resonant Q-factor. Moreover, a natural period of resonance of water within the port channels **50a, 50b, 50c, 50d** and

their associated columns **20a**, **20b**, **20c**, **20d** is susceptible to being computed from Equation 1 (Eq. 1):

$$T_n = 2\pi \sqrt{\frac{M}{k}} \quad \text{Eq. 1}$$

wherein

$T_n$  = period of resonance;

$M$  = mass of water in the port channel **50** and optionally its column **20**;

$k$  = coefficient of stiffness of water plane area.

5

As the mass  $M$  varies depending upon the height of water in the converter **10**, the converter **10** is beneficially optionally tuned to a frequency characteristic of ocean waves to be received at the converter **10** for obtaining optical energy conversion; such adjustment of height is  
 10 conveniently achieved by suitably ballasting a system onto which the converter **10** is mounted. In very severe storm conditions, the port channels **50a**, **50b**, **50c**, **50d** are beneficially submerged more deeply into the ocean to provide better protection against damage, especially in view of the ocean waves being surface waves such that most of their  
 15 energy field is close to the ocean surface.

Optionally, as illustrated in FIG. 1, the port arrangement **30** is fabricated from planar panels, for example steel panels of a type frequently used for contemporary ship building and offshore constructions. The panels are  
 20 beneficially cut to suitable size, for example by way of Carbon Dioxide laser cutting, and then assembled, or otherwise joined, together, for example by continuous welding seams formed at interfaces whereat the panels mutually meet. Moreover, the air columns **20a**, **20b**, **20c**, **20d** are beneficially implemented in cylindrical form as illustrated, wherein a  
 25 cylindrical form is best able to withstand pressure surges in adverse

weather conditions occurring within the columns **20a**, **20b**, **20c**, **20d**; moreover, a cylindrical form is often available in a form of standard component parts, for example continuously welded steel pipe, Carbon-fibre or fibreglass-reinforced composite materials pipes, marine-grade cast concrete pipes or any combination of these. Optionally, the air columns **20a**, **20b**, **20c**, **20d** are manufactured to have a polygonal cross-section, for example a rectangular cross-section or hexagonal cross-section. Optionally, the air columns **20a**, **20b**, **20c**, **20d** are manufactured from planar sheet components which are joined together, for example via continuous welding. Conveniently, as illustrated in FIG. 2, the pipes have a diameter C in a range of 1 metre to 2 metres, more preferably a diameter in a range of 1.3 metres to 1.9 metres, and most preferably a diameter of substantially 1.6 metres. The air columns **20a**, **20b**, **20c**, **20d** beneficially have an elongate length L in a range of 5 to 25 metres, and more preferably an elongate length L of substantially 14 metres up to a lower end of the energy pickoff devices **60**. Although FIG. 1 and FIG. 2 illustrate four columns **20a**, **20b**, **20c**, **20d** and an associated port arrangement **30** to suit, there are optionally included two or more columns **20** in the converter **10**. Optionally, for the converter **10**, the four columns **20a**, **20b**, **20c**, **20d** and associated port arrangement **30** are implemented as an integral assembly, for example as a mass-produced module.

Although the aforesaid converter **10** is beneficially operated so that the direction of wave propagation **40** is a forward direction as illustrated, it will be appreciated that the converter **10** can be used with waves arriving at the converter **10** from oblique angles, and even from a backwards direction which is opposite to the forward direction.

Referring to FIG. 2, the ports of the port arrangement **30** have an angular disposition of angles  $\theta_a$ ,  $\theta_b$ ,  $\theta_c$ ,  $\theta_d$  for the columns **20a**, **20b**, **20c**, **20d**

respectively, relative to an elongate axis of the columns **20a**, **20b**, **20c**, **20d** as illustrated. Optionally, the angles  $\theta_a$ ,  $\theta_b$ ,  $\theta_c$ ,  $\theta_d$  of the ports **50a**, **50b**, **50c**, **50d** are substantially  $10^\circ$ ,  $30^\circ$ ,  $50^\circ$ ,  $75^\circ$  respectively, although other angular dispositions are feasible for implementing the present invention. The air columns **20a**, **20b**, **20c**, **20d** beneficially have a separation distance  $G$ , wherein the distance  $G$  is optionally substantially 0.88 metres. Moreover, the port arrangement **30** optionally has a height  $K$  and a breadth  $J$  as illustrated in FIG. 2, wherein the height  $K$  is optionally substantially 8 metres and the breadth  $J$  is optionally substantially 10 metres. The port arrangement **30** beneficially has a width, as seen in a direction of the arrow **40**, of substantially 3 metres. Such sizes for the columns **20a**, **20b**, **20c**, **20d** and the port arrangement **30** are approximately comparable to a wavelength of ocean waves which the converter **10** is designed to convert to output power, for example output power from the energy pickoff devices **60**. Optionally, the columns **20a**, **20b**, **20c**, **20d** and the port arrangement **30** are of a size which enables resonant absorption of ocean waves to occur within the converter **10**, thereby enhancing conversion efficiency of the converter **10**. Optionally, the columns **20a**, **20b**, **20c**, **20d** are dynamically tuned in operation, for example by varying their effective length  $L$  and/or diameter  $C$ , for example by using actuated baffles or similar within the columns **20a**, **20b**, **20c**, **20d**.

The converter **10** is operable to steer incoming ocean waves approaching in a direction of the arrow **40** into a decelerating downwardly-directed vortex **45** which increases pressure of the vortex **45** with depth into the ocean and hence is especially efficient at extracting ocean wave energy in a relative small volume, without significant reflection or transmission of the ocean waves. Such a manner of operation is fundamentally different to known contemporary ocean wave energy converters.

The converter **10** is optionally designed to be arranged in arrays, wherein the arrays can be of curved form or linear form depending upon application in a system. For example, in FIG. 3, the port arrangement **30** designed to have a radially tapered form having a taper angle  $\theta_s$  in a range of  $15^\circ$  to  $30^\circ$ , and more optionally substantially  $23^\circ$ , with a length **M** in an order of 12 metres and widest width **W** of substantially 6.1 metres, although other sizes for the port arrangement **30** of FIG. 3 are feasible when implementing the present invention. The port arrangement **30** of FIG. 3 is conveniently manufactured by joining planar sheets of material together, for example by way of continuously welding sheet steel components together. Alternatively, the port arrangement **30** can be implemented as a reinforced concrete cast component.

The converter **10** as described in the foregoing is susceptible to being mounted onto various types of platform for implementing ocean wave energy systems. Alternatively, the converter **10** can be mounted in arrays to provide coastal defences, for example to reduce coastal erosion and/or to create calm ocean conditions in a wake of the arrays, for example for aquaculture and/or for harbour facilities.

Referring to FIG. 3B, the wave energy converter **10** is alternatively implemented, as indicated generally by **65**, such that, for a forward direction of ocean waves **40**, the five ports **50a**, **50b**, **50c**, **50d**, **50e** are arranged along the direction **40** and the five ports **50a**, **50b**, **50c**, **50d**, **50e** have progressively steeper angles for their elongate axes relative to a plane of an ocean surface **70** as the ports **50a**, **50b**, **50c**, **50d**, **50e** are disposed progressively deeper, namely as illustrated. Optionally, the port **50a** has its elongate axis at an angle of substantially  $45^\circ$  relative to the ocean surface **70**, and the port **50e** has its elongate axis substantially orthogonal relative to the ocean surface **70**; the intermediate ports **50b**,

**50c, 50d** have their elongate axes at intermediate angles between 45° and substantially orthogonal relative to the ocean surface **70**.

Referring next to FIG. 4, there is shown an ocean wave energy system indicated generally by **100**. The system **100** includes a buoyant platform **10** having a plurality of peripheral outwardly-projecting lobes **120**. For example, the platform **110** has a polygonal plan form, and the peripheral outwardly-projecting lobes **120** are disposed at facets of the polygonal plan form. Optionally, the platform **110** has a hexagonal plan form as illustrated. Optionally, the lobes **120** have outwardly-rounded peripheral edges along which a plurality of converters **10** are disposed as illustrated. Optionally, a plurality of the system **100** can be deployed along a coastline and anchored to a seabed; for example, the plurality of the systems **100** can be mutually coupled together, for example via chains or cables, to form a floating network. In storm conditions, the system **100** is robust, namely it is extremely difficult to cause it to flip over, and waves of excess magnitude are conveniently able to wash over an upper surface of the lobes **120** and the platform **110** and thereby dissipate their excess energy. The system **100** can be used for generating power, for example electrical power; alternatively, the system **100** can be used as a coastal defence or fjord defence to protect coastlines from a full impact of ocean waves, for example as a barrier against tsunami-type waves. The platform **110** and its lobes **120** are beneficially fabricated from one or more of: concrete, metal panels, plastics composite materials. Moreover, the converter **10** as illustrated in FIG. 4 is beneficial to employ when implementing the system **100**. During manufacture, the system **100** employs numerous mutually similar component parts which are susceptible to being mass-produced to reduce manufacturing cost. Moreover, the system **100** is beneficially assembled in calm water and then towed to its final location for deployment.

Referring next to FIG. 5, there is shown an alternative system indicated generally by **200**. The system **200** includes at its lower peripheral edge a plurality of the converters **10**, and a buoyant platform **210** thereabove including a peripheral safety railing **215**. Onto the platform **210** is included a service building **220**, for example personnel quarters and/or turbine generator facilities. Optionally, a helicopter pad **230** is included on a roof of the service building **220**. The system **200** is designed to float as an island, and the converters **10** are disposed in a ring-like manner substantially around a periphery of the platform **210** and are operable to provide electrical power to the service building **220**. Optionally, the service building **220** and the platform **210** have a polygonal form, for example a hexagonal form as illustrated. Optionally, the platform **210** overhangs the converters **10** in a vicinity of the railings **215**. In FIG. 6, an underside view of the system **200** is provided, illustrating that each converter **10** includes three ports **50a**, **50b**, **50c** whose depth into water increases progressively respectively in a direction towards a central vertical axis **240** of a central cylindrical base **250** of the system **200**; in other words, the port **50b** extends deeper into water than the port **50a** in operation, and the port **50c** extends deeper in operation into water than the port **50b** as illustrated. Moreover, the ports **50a**, **50b**, **50c** have progressively increasing angles  $\Theta$  relative to the central vertical axis **240** of symmetry of the system **200** in a direction towards the central vertical axis **240** of symmetry. The central cylindrical base **250** beneficially includes a heavy ballast mass at a lower portion thereof to provide the system **200** with intrinsic stability when floating in water; in other words the system **200** is buoyant in a manner of a floating island. The central base **250** is beneficially fabricated from reinforced marine-grade concrete and/or welded steel plate. Optionally, the system **200** is adapted to be mounted around a base of an offshore wind turbine, thereby providing a synergistic collocation of wind power generation and ocean wave power generation.

Referring next to FIG. 7, FIG. 8 and FIG. 9, there are shown illustrations of a system indicated generally by **300** and including a plurality of the aforementioned converters **10**. The system **300** is based upon a frame as

5 illustrated in FIG. 7, wherein the frame includes three hollow buoyant cylindrical towers **310a**, **310b**, **310c** disposed substantially at their upper ends at three corners of an equilateral triangular upper platform denoted by **320** as illustrated. Transverse members **330** mutually couple

10 substantially lower ends of the hollow buoyant cylindrical towers **310a**, **310b**, **310c** together as illustrated to provide a robust geometrical configuration for the frame. Diagonal members **340** coupling between the platform **320** and the hollow buoyant cylindrical towers **310a**, **310b**, **310c** are beneficially provided to provide the frame with enhanced

15 robustness to withstand severe ocean weather conditions when in operation. Superficially, the frame appears akin in its manner of construction to contemporary floating oil and gas exploration and production platforms, for example as contemporarily employed offshore in Norway to provide oil and gas exploration and production. The frame is

20 beneficially susceptible to being fabricated in shipyards which have hitherto manufactured aforesaid contemporary floating oil and gas exploration and production platforms. Optionally, the frame is fabricated from various steel components which are welded and/or bolted together. As

25 illustrated in FIG. 8, the frame is arranged to accommodate a plurality of converters **10** having ports **50a** to **50f** which are progressively of greater angle relative to vertical, and of greater depth towards a central vertical axis of the system **300** when deployed in operation. All the ports **50a** to **50f** face outwardly from the central vertical axis as illustrated. Optionally, the ports **50a** to **50f** have a circular cross-sectional profile as illustrated.

30 A service housing **350** is included for accommodating one or more generators, personnel and such like. In operation, it is beneficial that the cylindrical tower **310b** is orientated towards a prevailing ocean wave propagation direction. The system **300** is of benefit in that it can be

manufactured in regions of calm water and then towed out to its intended location of operation. Moreover, the system **300** is beneficially retained in position by one or more anchors secured to a seabed in a vicinity of where the system **300** is intended to operate. Beneficially, boat docking facilities are included between the cylindrical towers **310a**, **310c**, namely  
5 in a wake of the system **300** substantially devoid of ocean waves, for enabling maintenance vessels to dock with the system **300** when required. As illustrated in FIG. 9, the energy pickoff devices **60** are disposed substantially at a height of the platform **320** and are readily  
10 accessible to personnel accommodated in the service housing **350**; such deployment of the devices **60** enables the devices **60** to be conveniently repaired, serviced or replaced by personnel whilst the system **300** is in operation. Optionally, the devices **60** of the system **300** are coupled to a central turbine accommodated in the service housing **350**; alternatively,  
15 each device **60** includes its own turbine and generator so that each column **20** of the converters **10** is capable of functioning in a mutually autonomous manner. Beneficially, the devices **60** are remote from the ports **50** and hence, to an extent, are well protected from large magnitude waves in storm or hurricane conditions experienced at the  
20 ports **50**. In FIG. 9, an example converter **10** of the system **300** is shown inset, namely adjacent to, the system **300** for illustration purposes only.

Each converter **10** of the system **300** is capable in operation, for example in Norwegian, Japanese or Scottish offshore locations, of generating ten's  
25 of kiloWatts (kW) of power, such that the system **300** is potentially capable of generating in total an order of 10 MegaWatts (MW) to 500 MegaWatts (MW) of power, namely comparable to a small nuclear reactor but without any risk of radioactive contamination or thermal runaway. Moreover, the system **300** is capable of generating in its wake calmer  
30 ocean water which is conducive to supporting aquaculture. When its service life is complete, the system **300** can be towed into harbour, and its materials recycled for manufacturing other products. Such desirable

characteristics render the system **300** an attractive option for sustainable low-Carbon energy production at a cost which is potentially less than a total life-time-cycle cost of generating nuclear power. The system **300** is thus especially suitable for countries such as Japan which are seismically

5 active and thus unsuitable for nuclear power. The system **300** can be deployed in large numbers along a coastline, with spaces therebetween for allowing access to shipping, lifeboats and similar. Moreover, the system **300** can be deployed at distances offshore whereat they do not disfigure the natural beauty of coastlines. Additionally, the system **300**

10 has a relatively low height profile in comparison to offshore wind turbines, and hence does not interfere significantly with coastal radar. The system **300** is capable of being constructed in existing shipyards using known construction techniques, and hence represents an attractive product to manufacture when the demand for offshore oil and gas exploration and

15 production platforms eventually declines in future as a result of depletion of geological fossil oil and gas reserves. Optionally, the platform **320** can be provided with a protective cover fabricated, at least in part, from photovoltaic cells for converting solar radiation to electric power and also providing personnel with a more comfortable environment on the platform

20 **320** for servicing the energy pickoff devices **60**.

Optionally, the system **300** is provided with one or more submerged structures beneath the converters **10** for providing an optimal absorption of ocean wave energy. Optionally, the one or more submerged structures

25 are adjustable to provide dynamically controlled absorption, for example favouring certain specific wavelengths of ocean waves. Optionally, the one or more submerged structures are planar in form, and are disposed to enhance generation of the aforesaid vortex **45**. Optionally, buoyancy of one or more of the cylindrical towers **310a**, **310b**, **310c** is adjusted in

30 operation to raise or lower the ports **50** of the plurality of converters **10** for achieving optimal ocean wave energy absorption and/or optimal energy generation within the system **300**. Optionally, in severe storm or

hurricane conditions, buoyancy of one or more of the cylindrical towers **310a, 310b, 310c** is adjusted to lower the system **300** within an ocean environment for enabling the system **300** better to withstand such storms or hurricanes.

5

Referring next to FIG. 10, there is provided an illustration of an ocean wave energy system indicated generally by **500**. The system **500** is based upon a known conventional oil and gas platform including four cylindrical towers **520** at its extremities supporting an upper platform **510** and mutually coupled together via transverse and diagonal strengthening members **530**. From the platform **510** is suspended a single array of converters **10** whose port arrangement **30** is disposed substantially at or slightly below an upper surface of the ocean. A service facility building **540** is built onto the platform **510** and beneficially houses personnel, machinery, turbines, spare parts and similar. Optionally, an upper roof surface of the building **540** functions as a helicopter landing pad. The system **500** is beneficially anchored to a seabed of the ocean, and can be towed into position for deployment. Beneficially, the system **500** can also function as a connection point for cables, for example for supporting a wind farm. Optionally, one or more wind turbines can be constructed onto the upper platform **510** for enabling the system **500** to generate energy from both ocean waves and wind. Optionally, the upper platform **510** can support ocean thermal energy conversion (OTEC) power generation apparatus which is operable to generate power from temperature differences with depth encountered in the ocean in a vicinity of the system **500**; such OTEC is especially pertinent when the system **500** is employed in tropical oceans.

In order to provide an appreciation of dimensions of the system **500**, reference is made to FIG. 11. The cylindrical towers **520** are beneficially spaced apart by distances in a range of 100 metres to 500 metres. Optionally, there are included hundred's, or even thousand's, of columns

**20** and associated ports **50** and energy pickoff devices **60**. Moreover, the system **500** is potentially capable of generating at least 10's of Mega Watts (MW) of electrical power when in operation. A plurality of such systems **500** are susceptible to being coupled together in a spatially-  
5 disposed network to provide coastal defences, to create calmed water in a wake of the network which is suitable for aquaculture, for example algae and/or fish farming, to create calmed shipping channels, to provide coastal defences against coastal erosion, to provide floating prisons, to provide floating hotels and similar recreational areas (for example for tax-  
10 free sale of goods), and similar. Other systems pursuant to the present invention described in the foregoing are also susceptible to being employed for such diverse applications.

Referring next to FIG. 12, there is shown an ocean wave system indicated generally by **600**. The system **600** includes a floating platform fabricated from a plurality of hexagonal modules **610**, wherein the platform has thereby outwardly-projecting lobes which are optionally, at least in part, deployed with converters **10** having a port arrangement **30** of angular form as generally depicted in FIG. 3. At a substantially central portion of the platform is included one or more buildings **610**, for example living  
20 quarters, housings for equipment and similar. Optionally, the system **600** can be employed as a floating hotel, as floating luxury accommodation, as a floating prison, as a floating rehabilitation centre, a floating factory or similar.

25

In a passive manner of operation, the converters **10** are employed to absorb incoming waves to protect the platform during adverse weather conditions. In an active manner of operation, the converters **10** are employed to generate power for the one or more buildings, for example  
30 for heating, lighting, air conditioning and so forth. Optionally, the system **600** is employed as an ocean wave power generator for providing output power, for example via cables to land and/or to convert energy-bearing

materials transported to the system **600** which are subsequently collected from the system **600** when processed to increase their state of latent energy. Optionally, a plurality of the systems **600** are anchored to a seabed and coupled together, for example via chains wires, or cables to  
5 form a robust network over a surface of the ocean, for example for coastal erosion protection purposes. Optionally, the systems **600** are coupled together via electrical cables, for example to provide a cable network for an offshore wind farm having a spatially distributed arrangement of wind turbines.

10

Referring next to FIG. 13, there is shown an array of the converters **10**, wherein each converter **10** is equipped with a corresponding wave reflector **700** which is operable to in a submerged state. Optionally, the wave reflector **700** is implemented as a simple planar component, for  
15 example as a planar baffle. Alternatively, the wave reflector **700** is implemented as a robust 3-dimensional structure including a base **710**, side walls **720** and a back wall **730**. Optionally, the base **710** and the walls **720**, **730** are outwardly tapered towards a forward direction of wave propagation when in use. Optionally, the reflectors **700** are  
20 actuated to adjust their spatial positions relative to the ports **50** for obtaining optimal coupling of energy to the columns **20**. Use of the reflectors **700** is capable of improving energy coupling efficiency of the converter by a range of two to three times, namely a very significant improvement in wave energy conversion efficiency; such improvement  
25 can have a very beneficial impact on the economic attractiveness of the converter **10** for large-scale power generation. The wave reflectors **700** are beneficially fabricated from marine-grade reinforced concrete and/or metal.

30 Countries such as Japan that have a relatively restricted land area, a large population, a large requirement for aquatic food and a large requirement for energy can benefit greatly from the converter **10** and

systems incorporating the converter **10**. Such countries may have invested in conventional nuclear technology based upon Zirconia-clad fuel rods which generate considerable nuclear waste; the Zirconia cladding of contemporary fuel rods fails on account of neutron flux exposure before  
5 more than a few percent of Uranium or MOX fuel is utilized. Recently, great interest has revived regarding Thorium molten salt reactors which are capable of potentially generating large amounts of power with very little generation of nuclear waste; Thorium reactors were first investigated by Dr Alvin Weinberg at Oak Ridge National Laboratories in the 1950's  
10 and 1960's. Beneficially, a Thorium molten salt reactor can be configured to transmute contemporary stockpiles of nuclear waste and render them relatively harmless. Moreover, Thorium is a relatively plentiful material derived from Monazite ore, wherein circa 1 million tonnes of Monazite ore is to be found in the Telemark region of Norway. Systems pursuant to the  
15 present invention including the converters **10** are ideal for supporting Thorium molten salt reactor apparatus, wherein floating offshore Thorium reactor apparatus are well protected from tsunamis and also have copious cooling water readily available. As Japan now has huge stockpiles of nuclear waste, such Thorium reactor apparatus can synergistically provide  
20 Japan with copious amounts of power in a safe manner whilst also transmuting and thus safely disposing of Japan's stockpiles of nuclear waste. When Thorium molten salt reactors are provided with safety melt-plug arrangements, thermal runaway incidents such as occurred at Fukushima would be virtually impossible with such Thorium molten salt  
25 reactors. The Thorium salt configurations employed are beneficially Fluoride-based or Chloride-based. The converters **10** are beneficially employed to absorb incoming waves and thus protect such Thorium reactor apparatus from danger. In an event of a massive freak wave, for example a tsunami, platforms including converters **10** pursuant to the  
30 present invention would ride on a top of such massive waves and not sustain damage; moreover, the converters **10** employed beneficially synergistically contribute to power generation as well as performing an

ocean wave energy absorbing function. Presently, Thorium molten salt reactors are being considered for submarines wherein no refuelling would be required during the lifetime of the submarines on account of the efficient consumption of Thorium fuel within such reactors. Floating power stations based on aforesaid Thorium reactor apparatus and converters **10** for ocean wave energy absorption purposes can be deployed along coastlines as required, for example for emergency desalination of sea water to generate fresh water for famine-stricken areas. Contemporary companies such as Flibe Inc. (USA) and Rolls Royce (GB) are now believed to be working on rapid development programmes for Thorium molten salt reactors. Known Thorium reserves are estimated to be able to power the World at existing energy consumption rates presently derived from burning fossil fuels for a period in excess of 100000 years, given that suitable development of commercial designs of Thorium molten salt reactors can be executed.

The aforesaid converter **10** is susceptible to being employed in diverse applications to provide protection against ocean waves and/or to generate energy from ocean waves. Rows and arrays of the converter **10** can be used, for example, to provide coastal defences against waves, wave protection along floating bridges, wave protection around offshore aquaculture facilities, harbours, floating islands, buoys, and such like.

The converter **10**, in its various implementations as described in the foregoing, beneficially employs nanotechnology to enhance its performance. Beneficially, inside surfaces of the columns **20** and the port arrangement **30** are coated with a layer of nano-particle material which hinders growth of algae and similar aquatic biota. Moreover, where concrete material is employed when implementing the converter **10**, or systems incorporating the converter **10**, the concrete material is beneficially of closed-pore type which is capable of withstanding decades of use in marine environments without substantially degradation.

Moreover, the concrete material itself is beneficially strengthened by incorporation of nano-fibres therein, for example Carbon tubules which exhibit a strength-to-weight performance many orders of magnitude greater than high-tensile steel.

5

Modifications to embodiments of the invention described in the foregoing are possible without departing from the scope of the invention as defined by the accompanying claims. Expressions such as "including", "comprising", "incorporating", "consisting of", "have", "is" used to describe and claim the present invention are intended to be construed in a non-exclusive manner, namely allowing for items, components or elements not explicitly described also to be present. Reference to the singular is also to be construed to relate to the plural. Numerals included within parentheses in the accompanying claims are intended to assist understanding of the claims and should not be construed in any way to limit subject matter claimed by these claims.

10  
15

**CLAIMS**

1. A wave energy converter for converting in operation energy conveyed  
5 in ocean waves propagating in a wave propagation direction in an ocean  
environment and received at the converter into generated power,  
comprising:  
a plurality of columns which are in fluidic communication via  
corresponding ports to the ocean waves received at the converter,  
10 wherein the ports are arranged substantially in series along the wave  
propagation direction, and wherein the ports are of progressively greater  
depth into the ocean environment along the wave propagation direction  
so as to cause a first component of the ocean waves to propagate in a  
downward direction and a second component of the ocean waves to  
15 propagate into the ports to couple energy thereto, and  
the plurality of columns are arranged with elongate axes  
substantially aligned along a first direction, and such that the ports have  
corresponding port angles relative to the first direction which are  
progressively larger or smaller as the ports are of progressively greater  
20 depth.
2. The wave energy converter as set forth in claim 1, wherein the first  
direction is a substantially vertical direction when the converter is in  
operation.
- 25 3. The wave energy converter as set forth in claim 1, wherein the ports  
have an elliptical, round or rectilinear cross-section.
4. The wave energy converter as set forth in claim 1, wherein the plurality  
30 of columns are operable to couple to the ocean waves received at the  
ports in a resonant manner.

5 5. The wave energy converter as set forth in claim 1, wherein the columns include corresponding energy pickoff devices at upper regions thereof, at lower regions thereof, in ports thereof or at combinations thereof.

10 6. The wave energy converter as set forth in claim 1, wherein the converter includes between 2 and 10 columns and associated ports arranged in series.

15 7. The wave energy converter as set forth in claim 1, wherein the converter includes one or more submerged wave reflectors in a vicinity of the ports of the converter for reflecting the ocean waves more efficiently into the ports.

20 8. A method of converting energy conveyed in ocean waves propagating in a wave propagation direction in an ocean environment when received at a wave energy converter to generate power, comprising:

(a) arranging for the converter to include a plurality of columns which are in fluidic communication via corresponding ports to the ocean waves received at the converter;

(b) arranging for the ports to be substantially in series along the wave propagation direction; and

(c) arranging for the ports to be of progressively greater depth into the ocean environment along the wave propagation direction so as to cause a first component of the ocean waves to propagate in a downward direction and a second component of the ocean waves to propagate into the ports to couple energy thereto,

wherein said method includes arranging the plurality of columns with elongate axes substantially aligned along a first direction, and such that the ports have corresponding port angles relative to the first

direction which are progressively larger or smaller as the ports are of progressively greater depth.

5

1/14

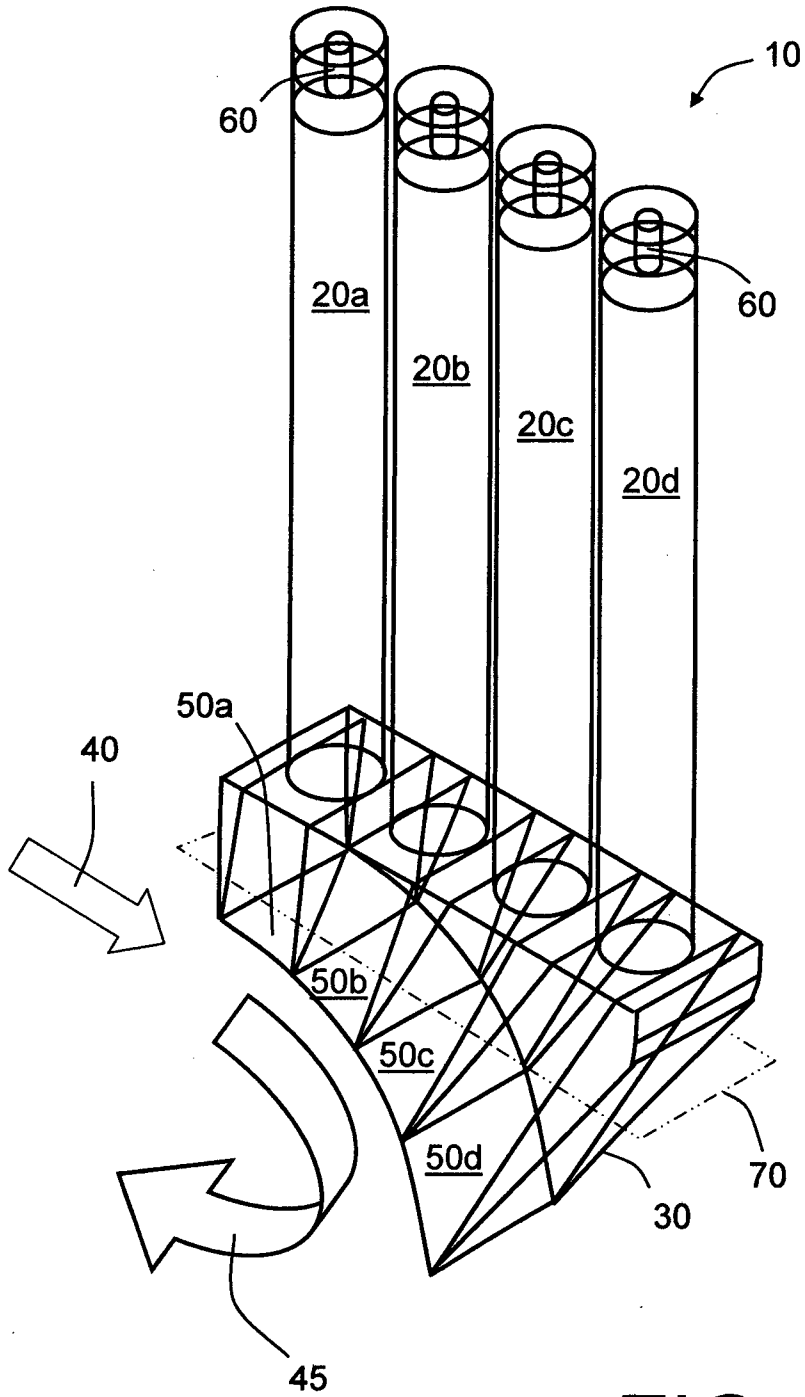

FIG. 1

2/14

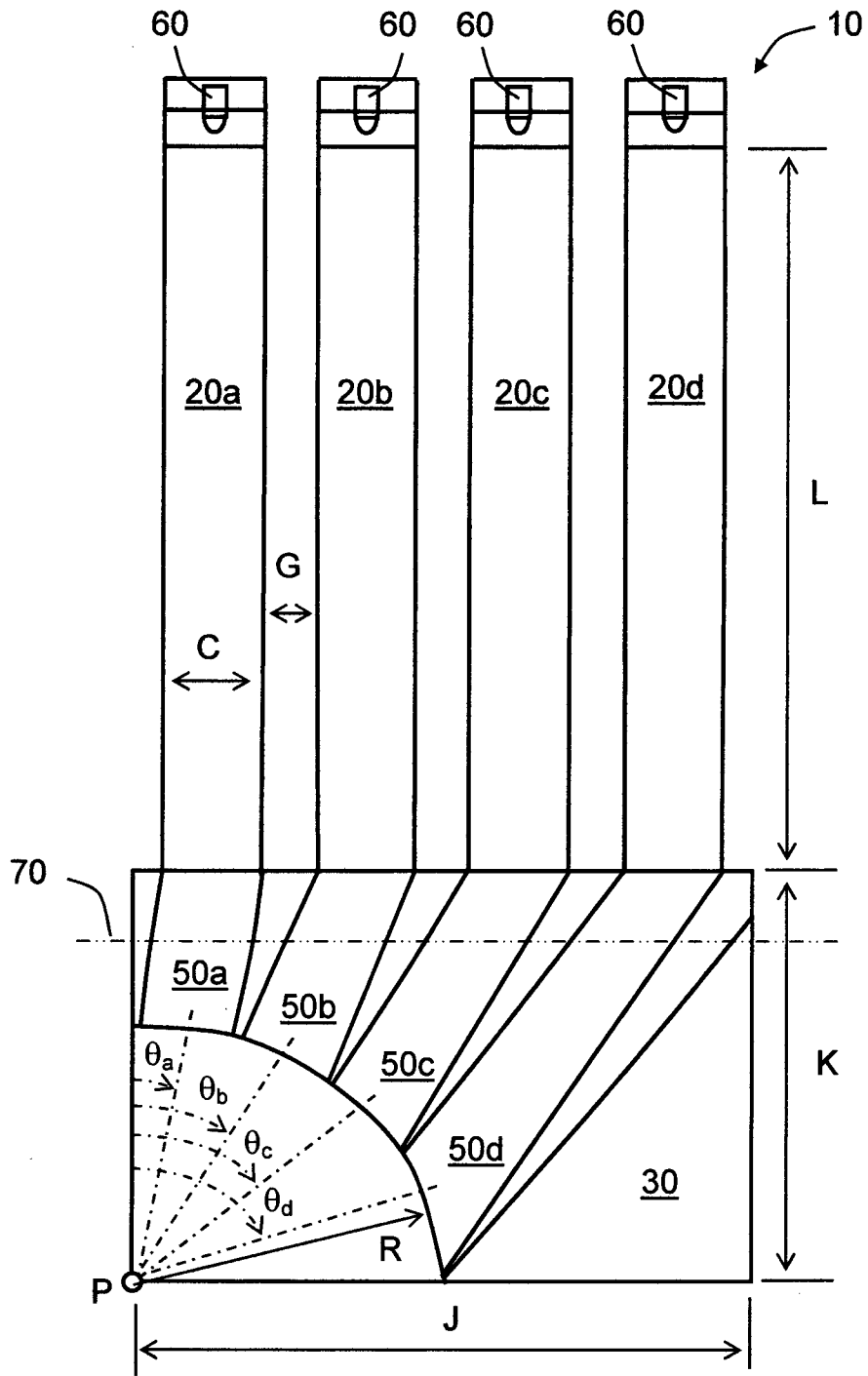

FIG. 2

3/14

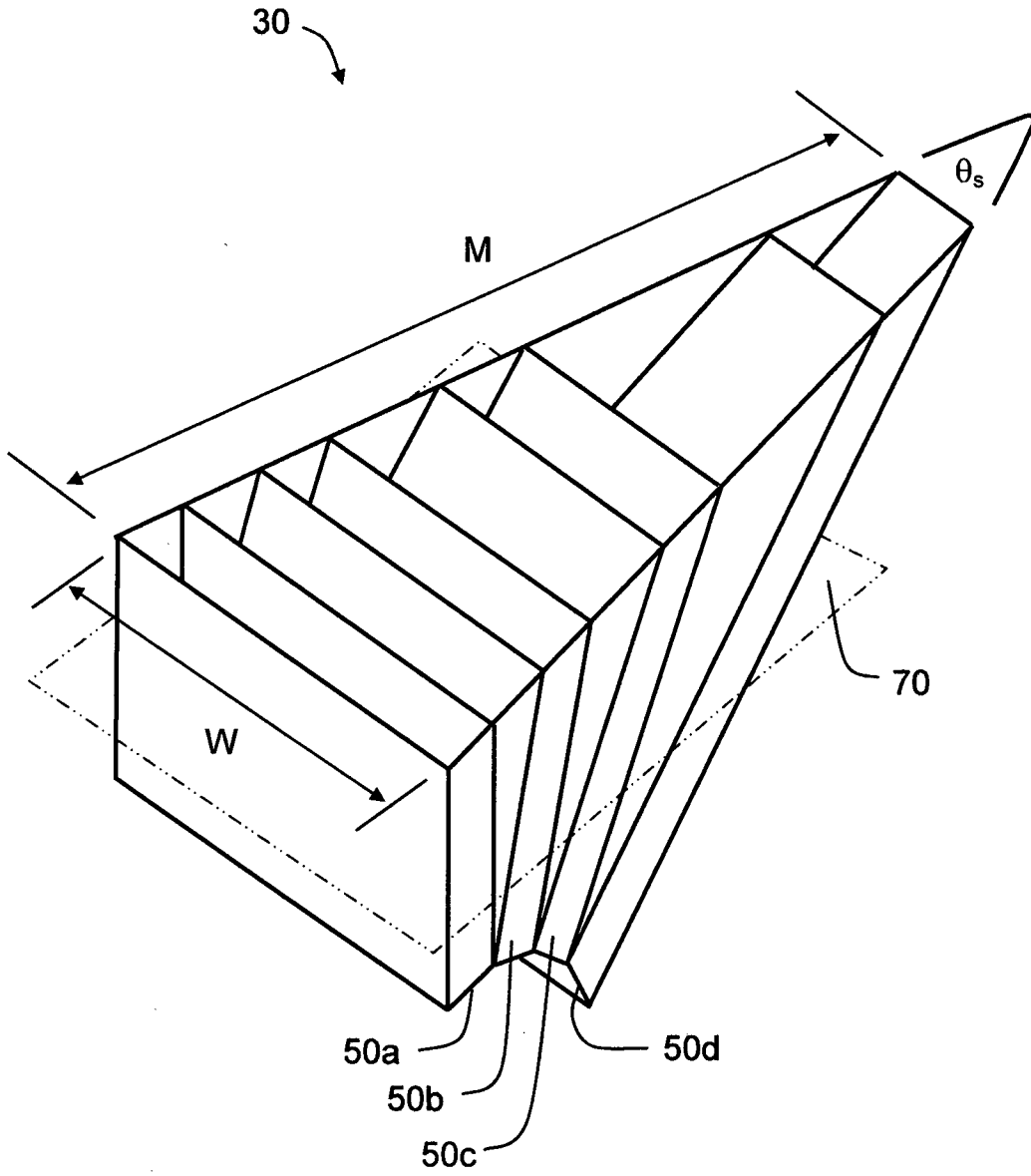

FIG. 3A

4/14

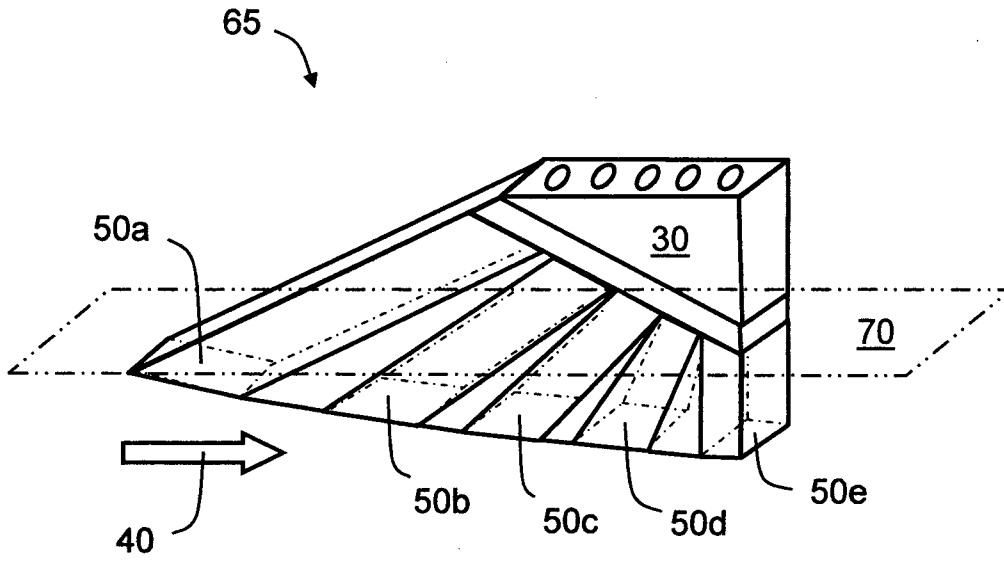

FIG. 3B

5/14

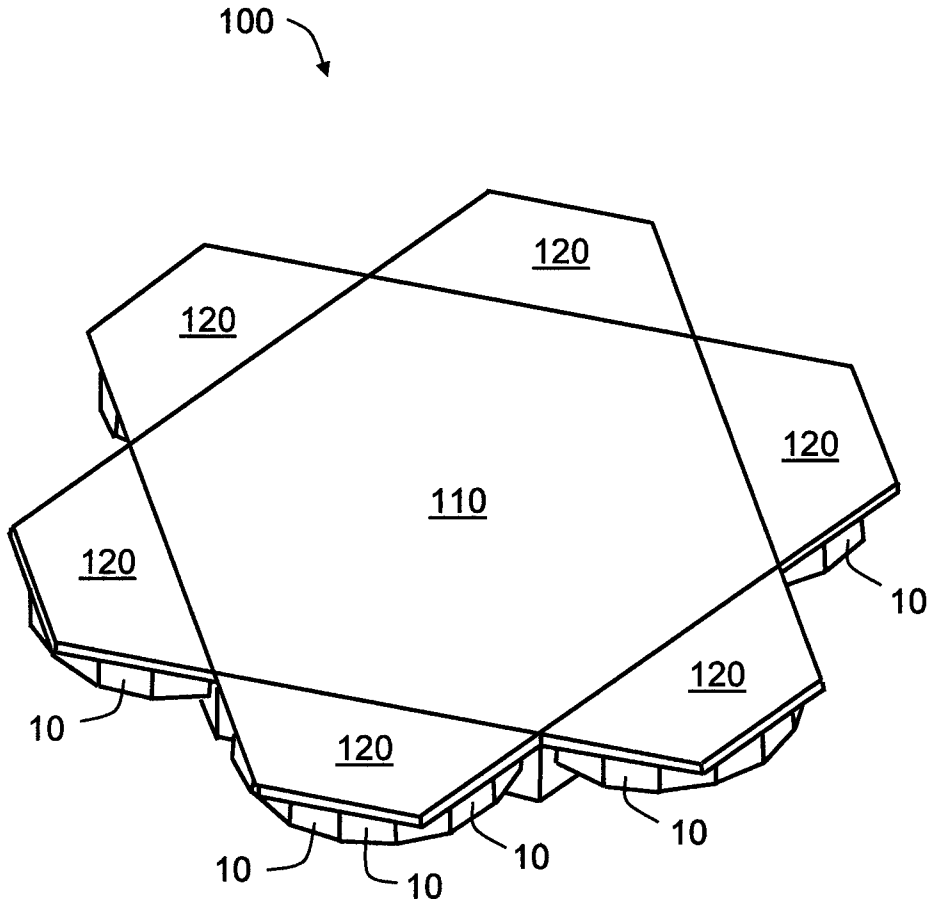

FIG. 4

6/14

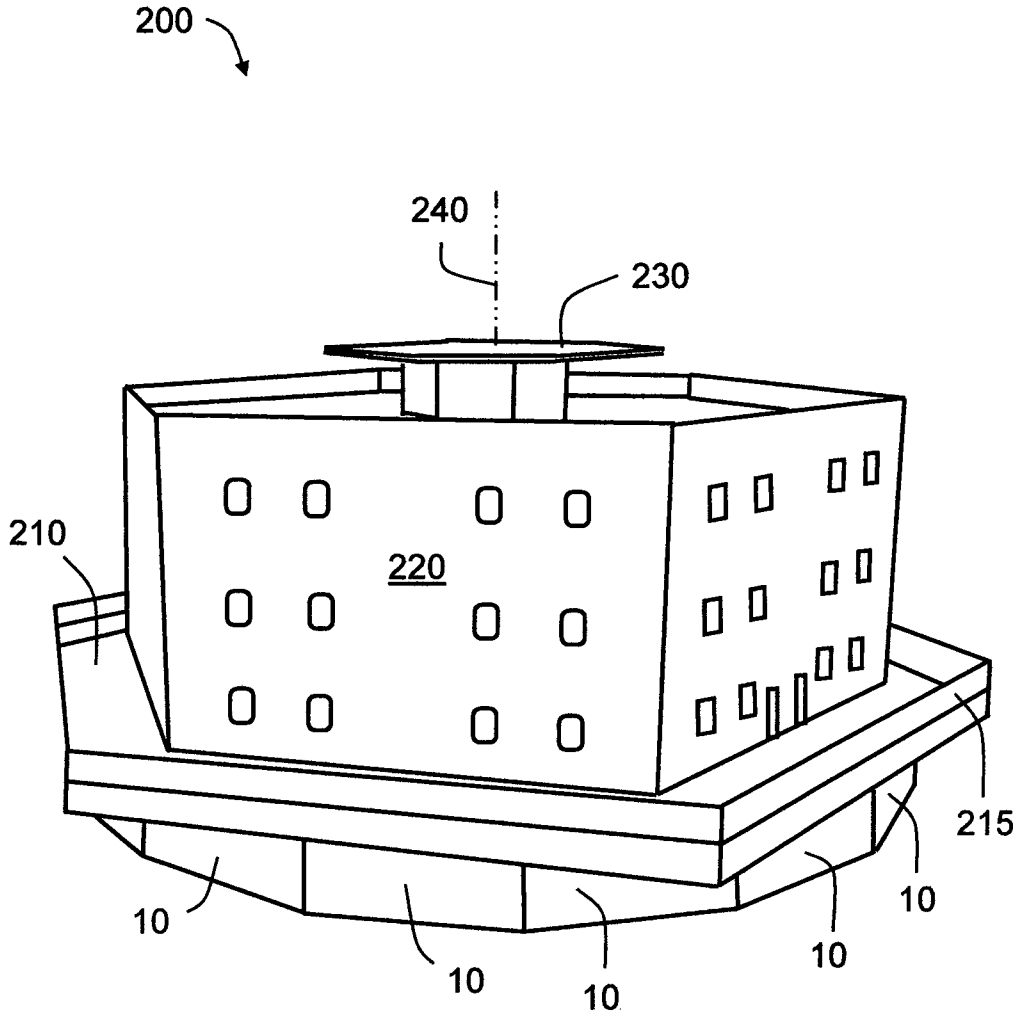

FIG. 5

7/14

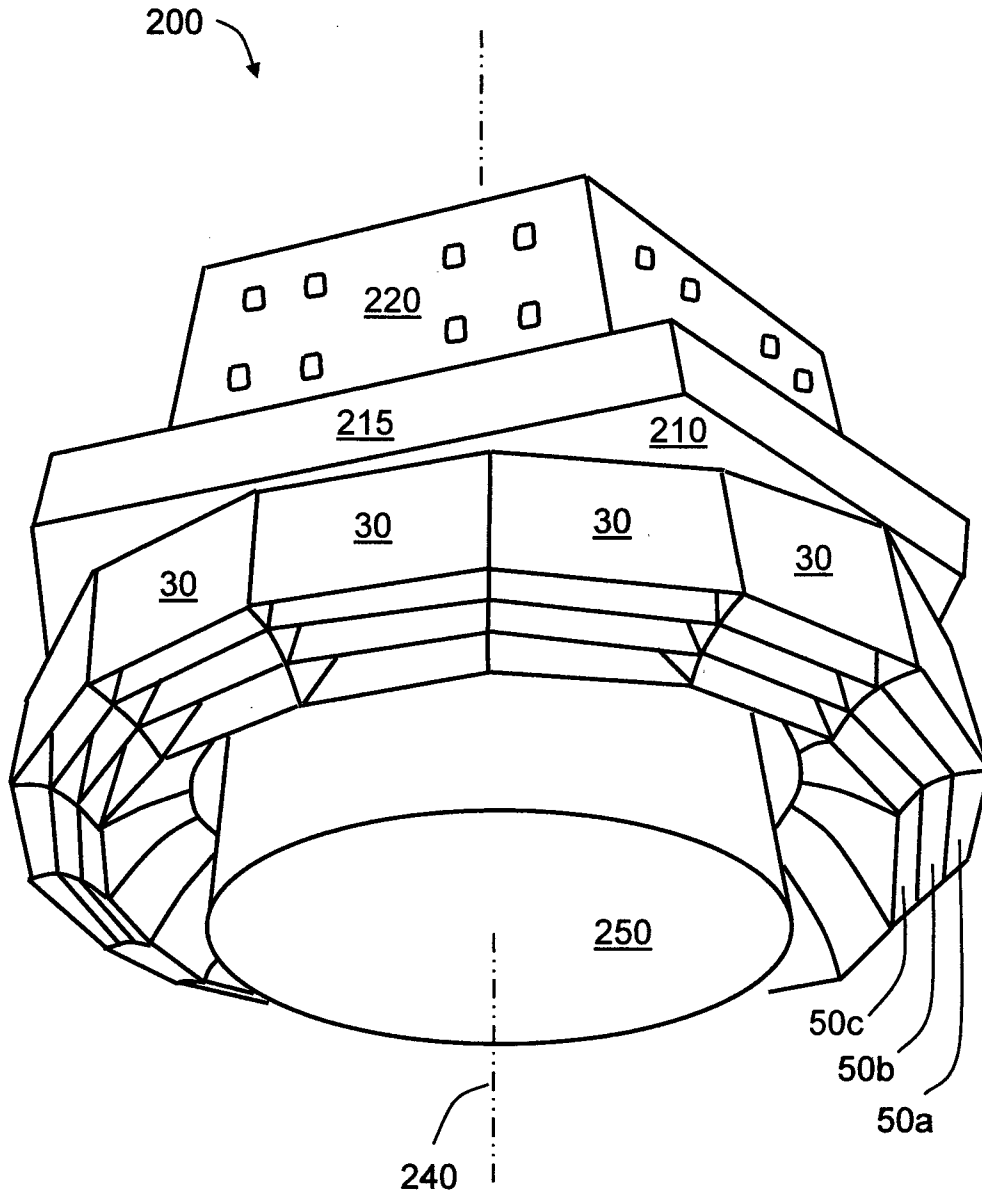

FIG. 6

8/14

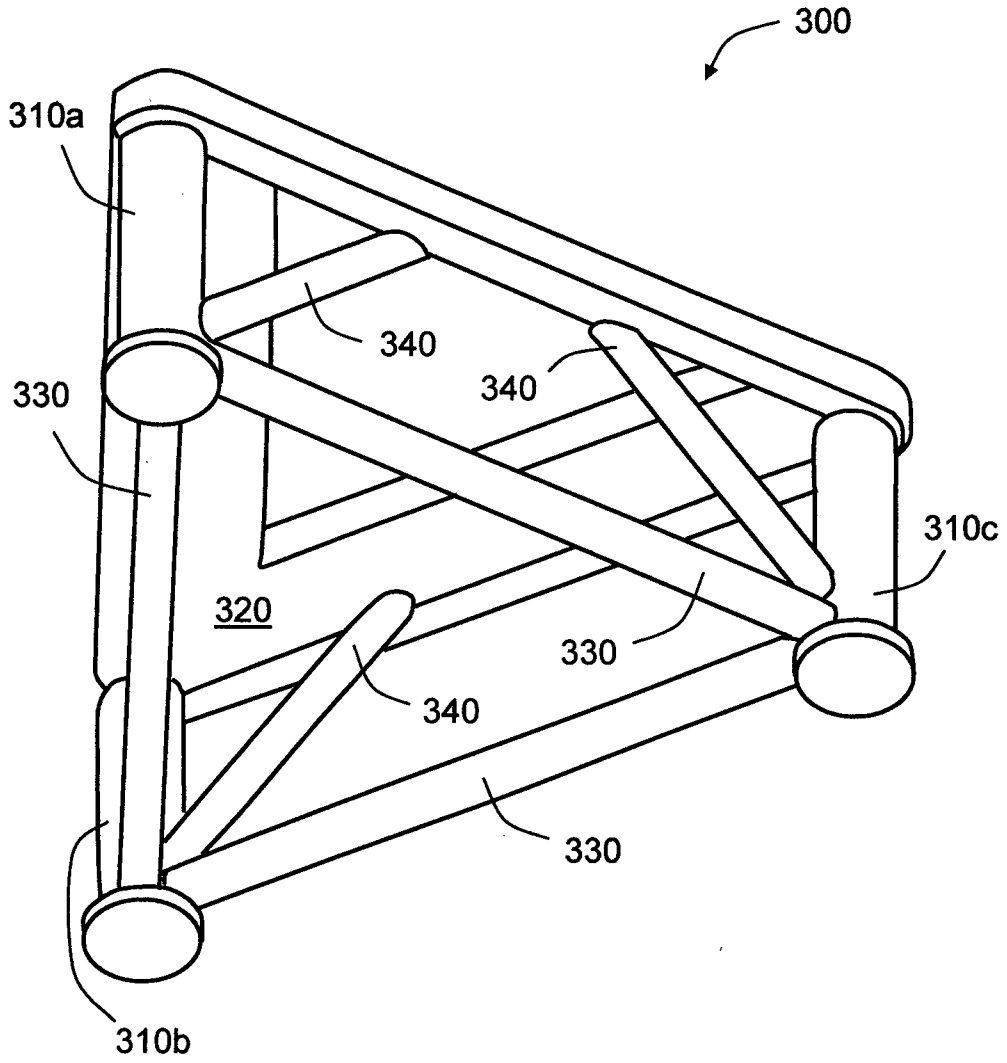

FIG. 7

9/14

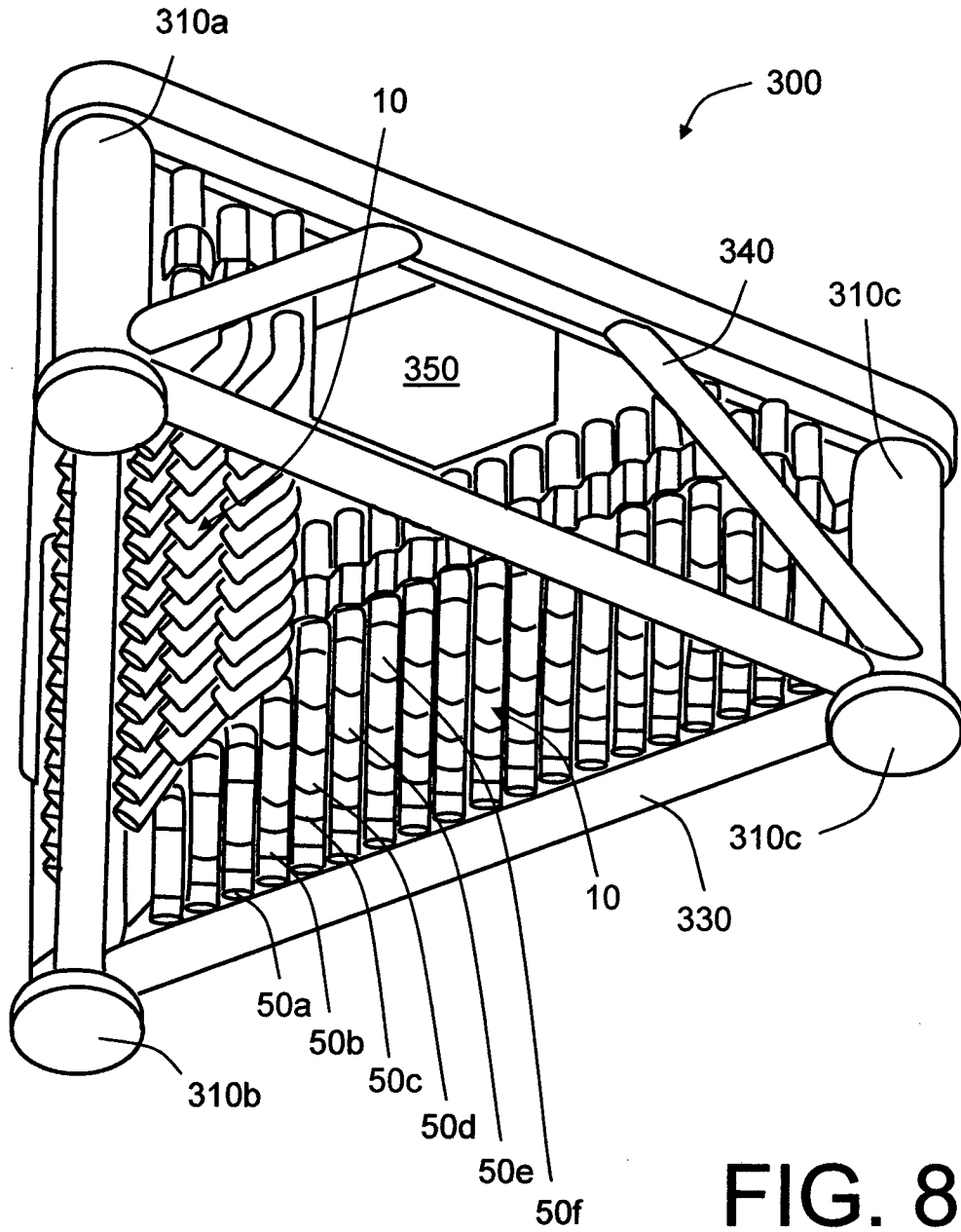

FIG. 8

10/14

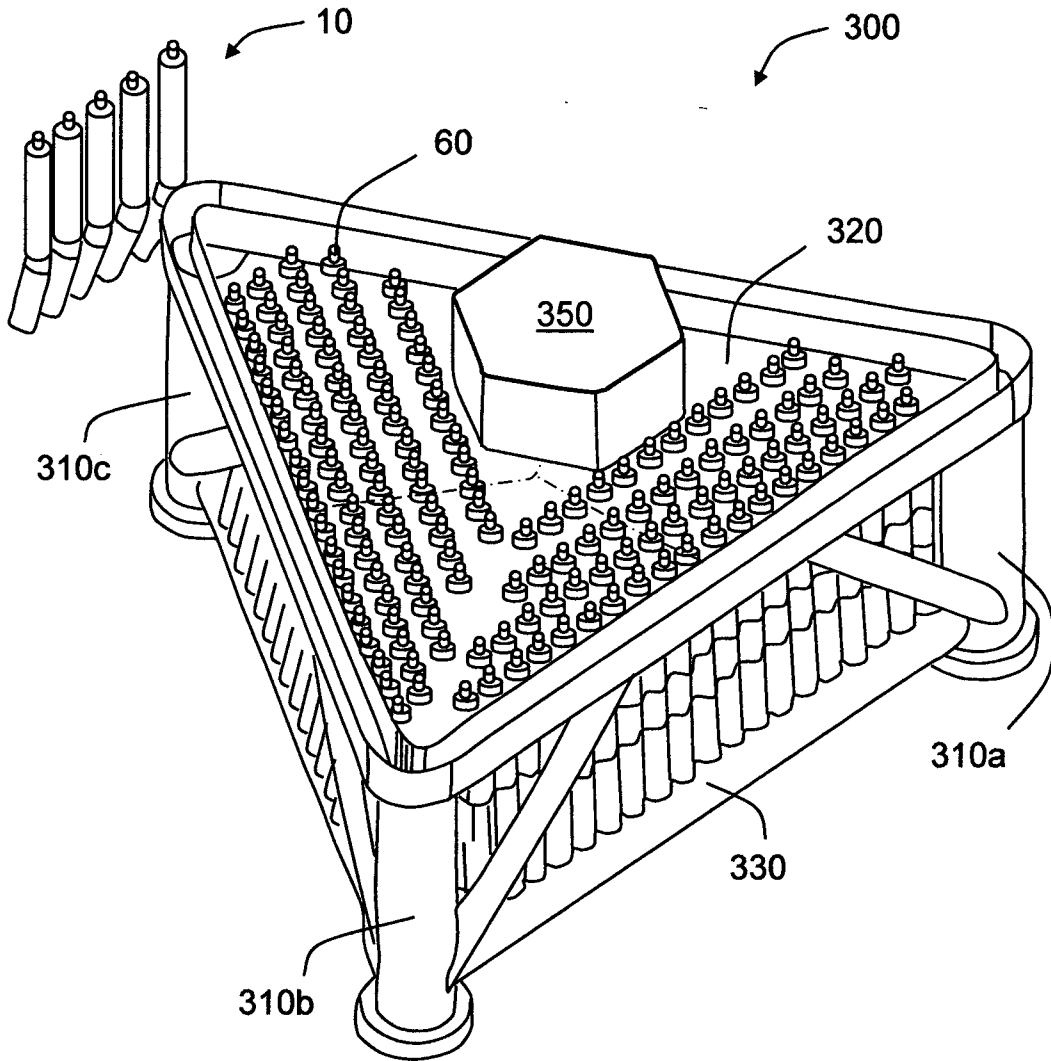

FIG. 9

11/14

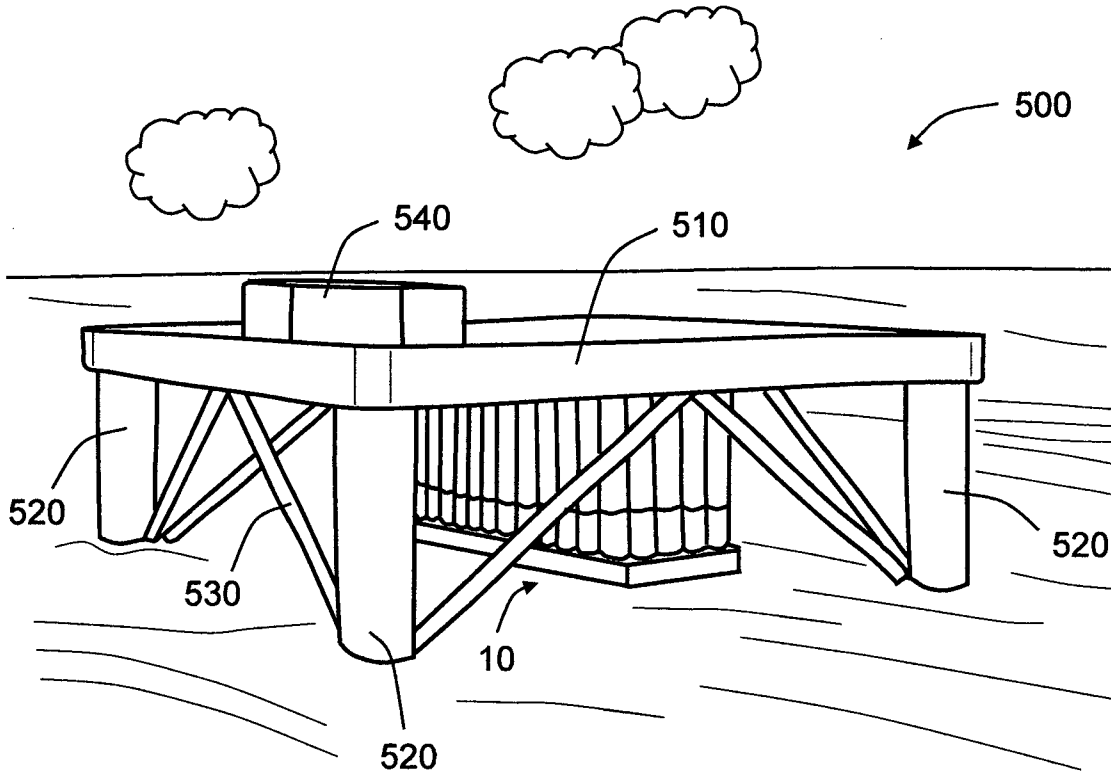

FIG. 10

12/14

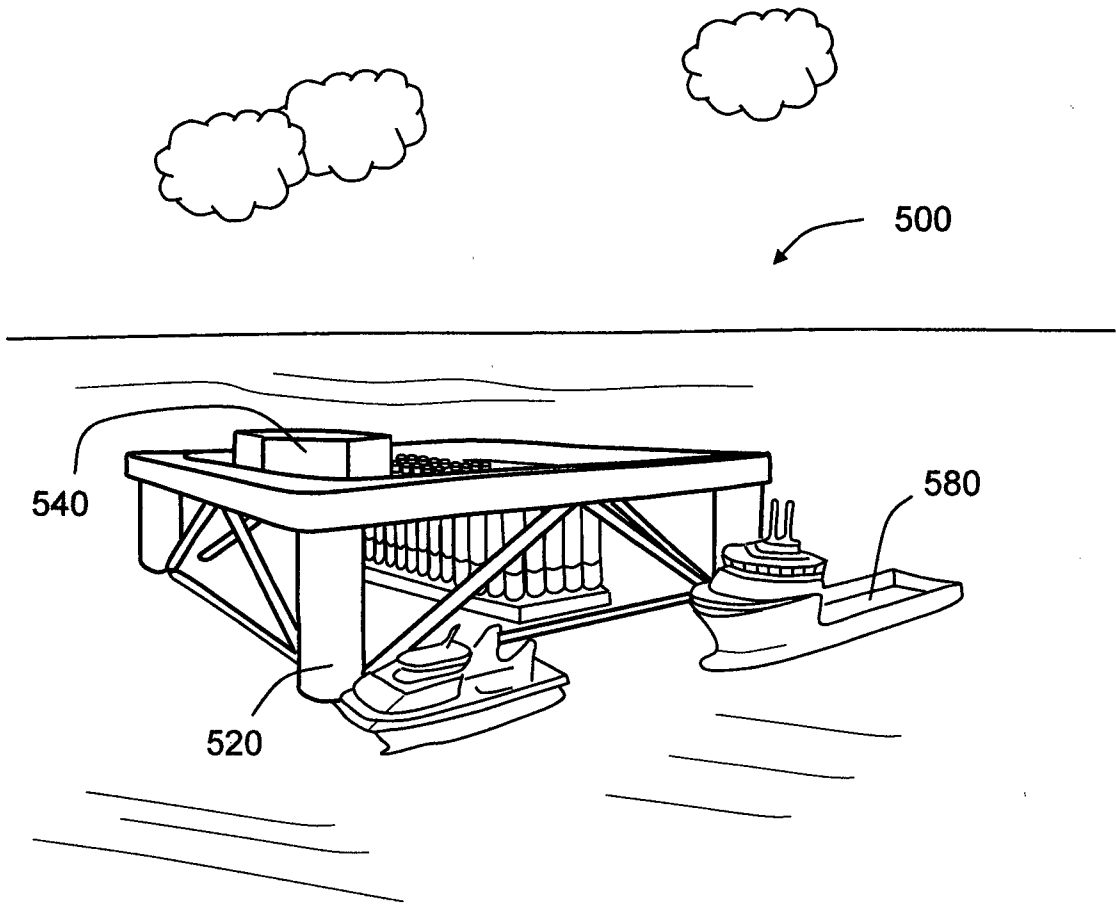

FIG. 11

13/14

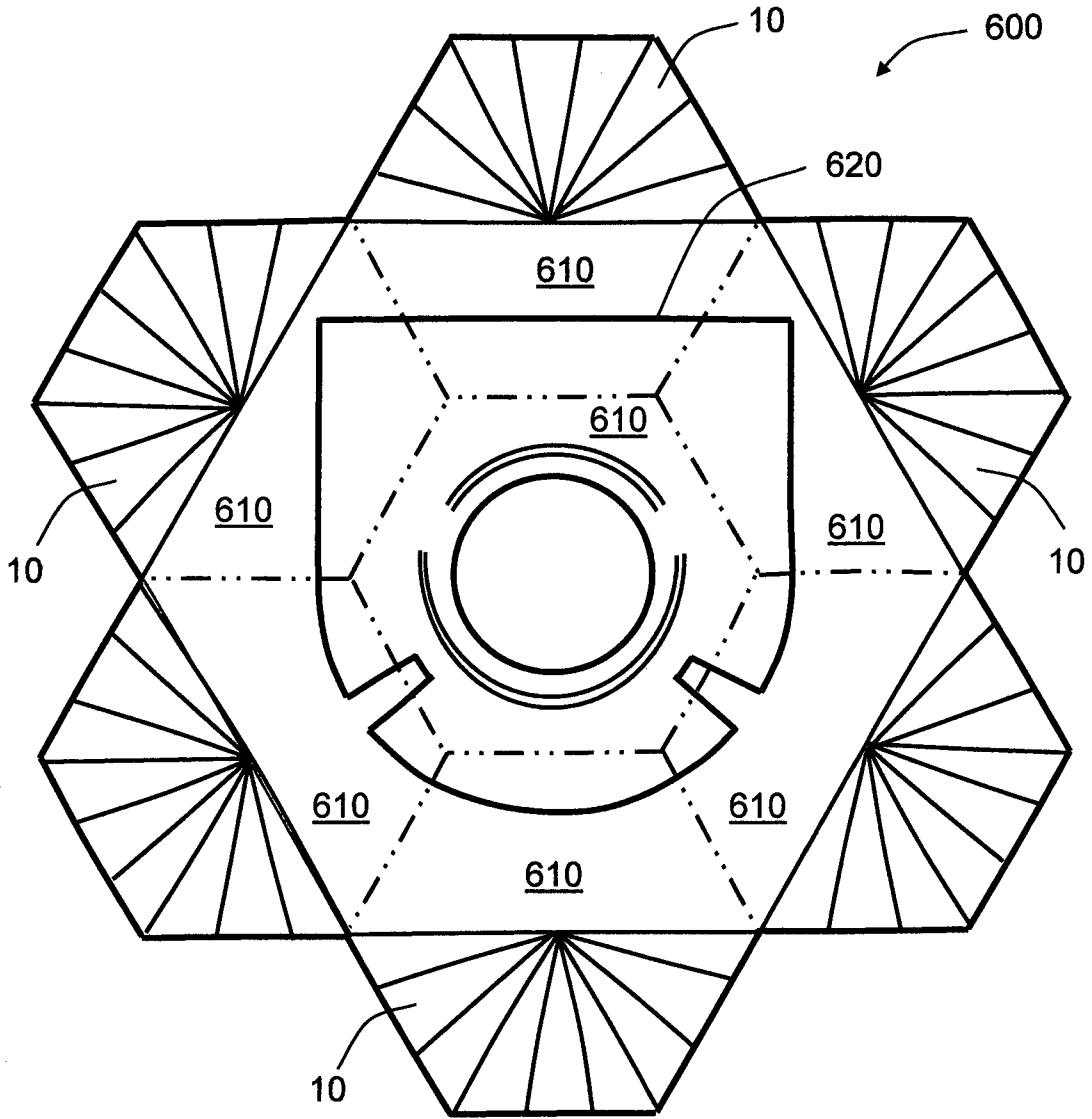

FIG. 12

14/14

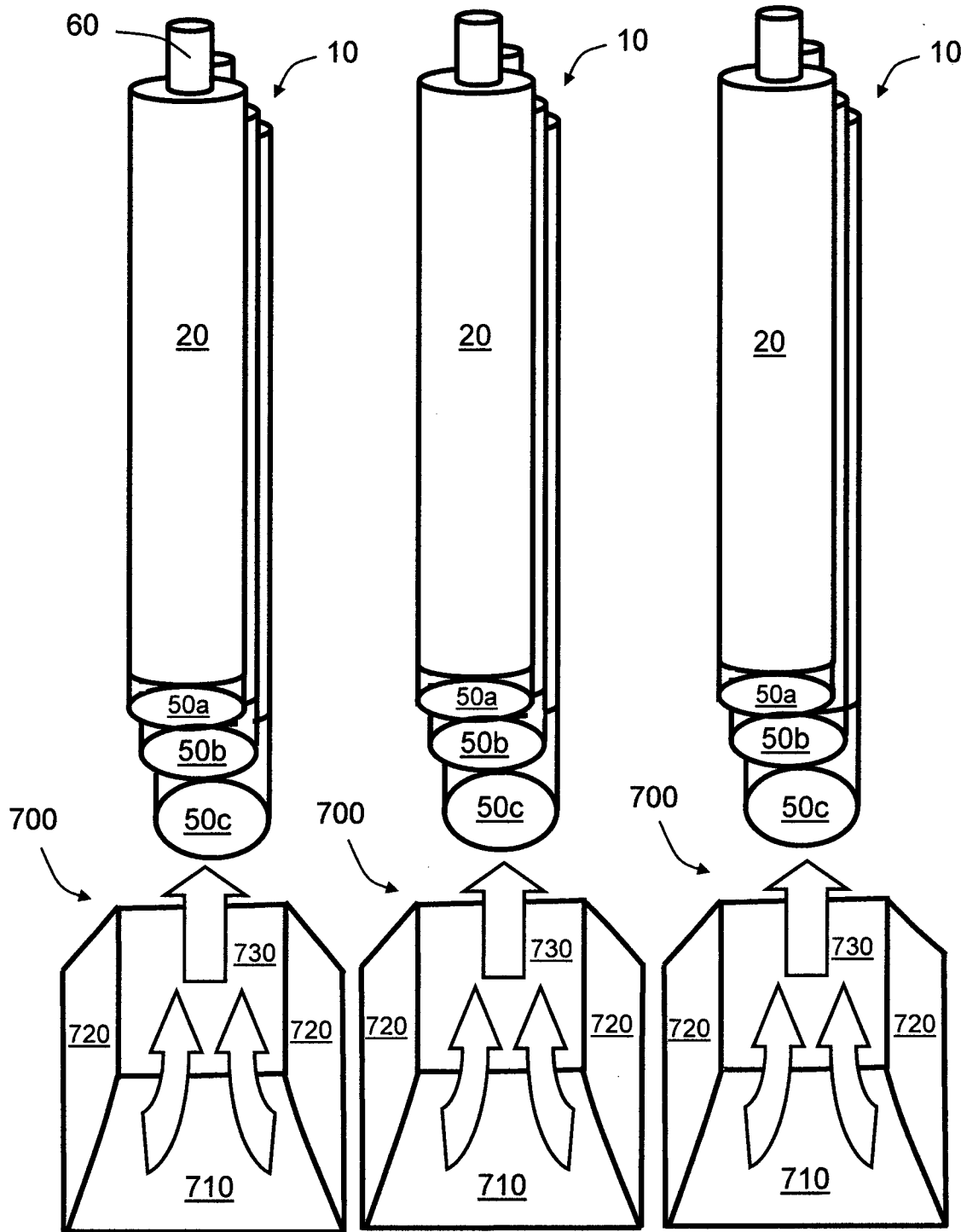

FIG. 13

