



INTERNATIONAL APPLICATION PUBLISHED UNDER THE PATENT COOPERATION TREATY (PCT)

<p>(51) International Patent Classification ⁵ : B29D 11/00</p>	<p>A2</p>	<p>(11) International Publication Number: WO 92/12851 (43) International Publication Date: 6 August 1992 (06.08.92)</p>
--	------------------	--

(21) International Application Number: PCT/US92/00327
(22) International Filing Date: 13 January 1992 (13.01.92)

(30) Priority data:
642,614 17 January 1991 (17.01.91) US
800,561 6 December 1991 (06.12.91) US

(71) Applicant: OPHTHALMIC RESEARCH GROUP INTERNATIONAL CORP. [US/US]; 4415 Poplar Level Road, Louisville, KY 40233 (US).

(72) Inventors: BUAZZA, Omar, M. ; 600 Sherburn Lane, Louisville, KY 40207 (US). LIPSCOMB, N., Thornton ; 7912 Circle Crest Road, Louisville, KY 40222 (US). LUTKE, Stephen, C. ; 4200 Billtown Road, Louisville, KY 40299 (US). ROBINSON, John, J. ; 1071 Celestial Street Apt. 1404, Cincinnati, OH 45202 (US).

(74) Agent: MEYERTONS, Eric, B.; Arnold, White & Durkee, P.O. Box 4433, Houston, TX 77210 (US).

(81) Designated States: AT, AT (European patent), AU, BB, BE (European patent), BF (OAPI patent), BG, BJ (OAPI patent), BR, CA, CF (OAPI patent), CG (OAPI patent), CH, CH (European patent), CI (OAPI patent), CM (OAPI patent), CS, DE, DE (European patent), DK, DK (European patent), ES, ES (European patent), FI, FR (European patent), GA (OAPI patent), GB, GB (European patent), GN (OAPI patent), GR (European patent), HU, IT (European patent), JP, KP, KR, LK, LU, LU (European patent), MC (European patent), MG, ML (OAPI patent), MN, MR (OAPI patent), MW, NL, NL (European patent), NO, PL, RO, RU, SD, SE, SE (European patent), SN (OAPI patent), TD (OAPI patent), TG (OAPI patent).

Published
Without international search report and to be republished upon receipt of that report.

(54) Title: METHOD AND APPARATUS FOR THE PRODUCTION OF PLASTIC LENSES

(57) Abstract

Method, apparatus and composition for making a plastic lens. The method comprises disposing a liquid monomer or a monomer mixture and a photosensitive initiator into a mold cavity and directing ultraviolet light to act on the lens forming material in the cavity to produce a lens therefrom.

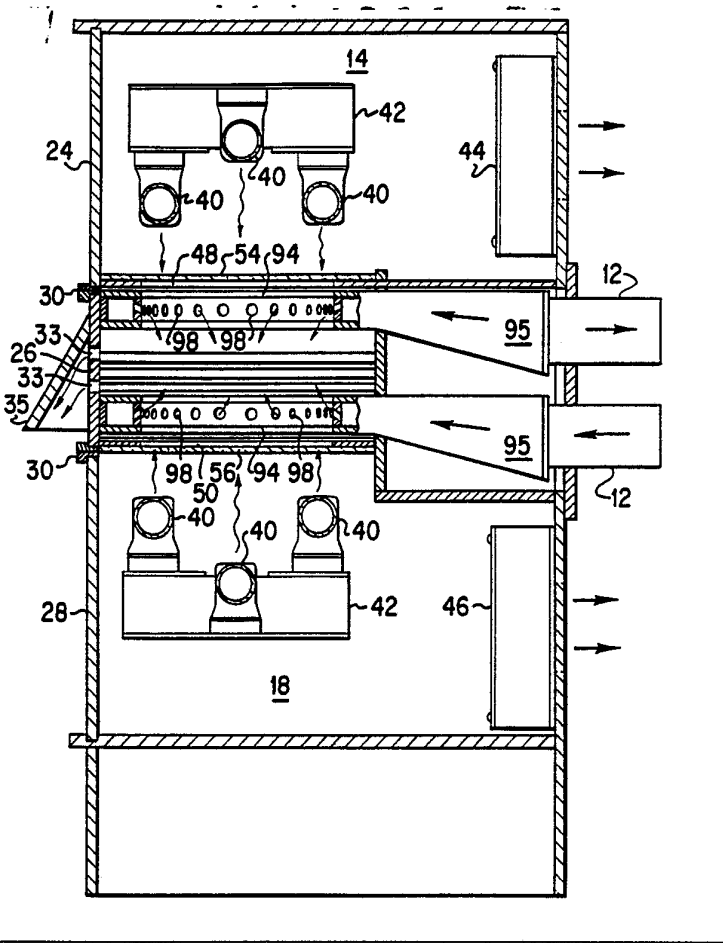

FOR THE PURPOSES OF INFORMATION ONLY

Codes used to identify States party to the PCT on the front pages of pamphlets publishing international applications under the PCT.

AT	Austria	FI	Finland	MI	Mali
AU	Australia	FR	France	MN	Mongolia
BB	Barbados	GA	Gabon	MR	Mauritania
BE	Belgium	GB	United Kingdom	MW	Malawi
BF	Burkina Faso	GN	Guinea	NL	Netherlands
BG	Bulgaria	GR	Greece	NO	Norway
BJ	Benin	HU	Hungary	PL	Poland
BR	Brazil	IE	Ireland	RO	Romania
CA	Canada	IT	Italy	RU	Russian Federation
CF	Central African Republic	JP	Japan	SD	Sudan
CG	Congo	KP	Democratic People's Republic of Korea	SE	Sweden
CH	Switzerland	KR	Republic of Korea	SN	Senegal
CI	Côte d'Ivoire	LI	Liechtenstein	SU	Soviet Union
CM	Cameroon	LK	Sri Lanka	TD	Chad
CS	Czechoslovakia	LU	Luxembourg	TG	Togo
DE	Germany	MC	Monaco	US	United States of America
DK	Denmark	MG	Madagascar		
ES	Spain				

-1-

METHOD AND APPARATUS FOR
THE PRODUCTION OF PLASTIC LENSES

The present invention relates generally to methods,
5 apparatus and compositions for making plastic lenses.

It is conventional in the art to produce optical
lenses by thermal curing techniques from the polymer of
diethylene glycol bis(allyl)-carbonate (DEG-BAC).
10

The polymer of DEG-BAC exhibits desirable optical
and mechanical properties. These properties include high
light transmission, high clarity, and high index of
refraction together with high abrasion and impact
15 resistance. These properties in the past made DEG-BAC
one of the leading monomers in the manufacture of high
quality lenses, face shields, sun and safety glasses.
Other properties of DEG-BAC, however, such as its slow
rate of polymerization, make it an undesirable monomer in
20 the manufacture of these items. Moreover, DEG-BAC,
without any additives or co-monomers, produces a hard but
somewhat brittle polymer that is very prone to cracking.
In addition, DEG-BAC, without additives, tends to adhere
tightly to the lens forming molds, often leading to
25 cracking of the molds.

In addition, the thermal curing techniques for
polymerizing DEG-BAC to produce optical lenses have
several disadvantages and drawbacks. One of the most
30 significant drawbacks is that it may take approximately
12 hours to produce a lens according to thermal curing
techniques. A lens forming mold, therefore, can produce
at most two lenses per day.

35 Moreover, thermal curing techniques employ a thermal
catalyst so that a polymerizable mixture of DEG-BAC and

-2-

catalyst will slowly polymerize even while refrigerated. The polymerizable mixture therefore has a very short shelf life and must be used within a short time or it will harden in its container.

5

Furthermore, the thermal catalysts utilized according to the thermal curing techniques are quite volatile and dangerous to work with, thus requiring extreme care in handling.

10

Curing of a lens by ultraviolet light presents certain problems that must be overcome to produce a viable lens. Such problems include yellowing of the lens, cracking of the lens or mold, optical distortions in the lens, and premature release of the lens from the mold.

15

The present invention is directed to methods, apparatus and compositions for making plastic lenses that overcome the disadvantages and drawbacks of the prior art.

20

The present invention provides methods, apparatus and compositions for making plastic lenses, such as optical lenses for use in eyeglasses and the like.

25

In one embodiment of the present invention, a method for making plastic lenses is provided in which a polymerizable lens forming material is disposed in a mold cavity defined in part between a first mold member and a second mold member spaced apart from each other by a gasket. Rays of ultraviolet light are directed against either or both of the first and second mold members or the gasket. In a preferred embodiment, the first and second mold members are cooled. In another preferred embodiment, the ultraviolet light is filtered before it

30
35

impinges on either or both of the first and second mold members.

In another embodiment of the present invention, an apparatus is provided for making plastic lenses which includes a first mold member and a second mold member spaced apart by a gasket, wherein the first and second mold members define a mold cavity. The apparatus includes a generator for generating and directing ultraviolet light against at least one of the first and second mold members. Alternatively, the apparatus includes a generator for generating and directing ultraviolet light against the gasket. The apparatus may also include a means for preventing the transmission of ultraviolet light through the first and second mold members. In addition, the apparatus may include a filter for filtering the ultraviolet light. The filter may be disposed between the generator for generating and directing ultraviolet light and the first mold member, and between the generator for generating and directing ultraviolet light and the second mold member. The apparatus may include a fluid (e.g. air) distributor or a liquid bath for cooling the first and second mold members.

In another embodiment of the invention, the lens forming material may be cooled at relatively low temperatures while being exposed to ultraviolet ("UV") light. The lens forming material may be cooled by directing various flowrates of cooling air towards the mold members. The mold members themselves may be made thinner or thicker to achieve optimum lens curing results. Different lens curvatures may be made from the same mold members by varying the UV intensity patterns on the mold members during cure of the lens forming material. Hardness, cure and rigidity of the lenses made

-4-

as described above may be improved by demolding the lenses and then subjecting the lenses to high intensity UV light and/or heating.

5 In still another embodiment of the present invention, a photoinitiator is provided which includes methyl benzoylformate. The photoinitiator may be used with a composition that includes at least one polyethylenic-functional monomer containing two
10 ethylenically unsaturated groups selected from acrylyl and methacrylyl. The photoinitiator may be used with a composition that includes at least one polyethylenic-functional monomer containing three ethylenically unsaturated groups selected from acrylyl and methacrylyl.
15 The compositions may include an aromatic containing bis(allyl carbonate)-functional monomer such as bisphenol A bis (allyl carbonate). The compositions may include 1,6 hexanediol dimethacrylate, trimethylolpropane triacrylate, tetraethylene glycol diacrylate and/or
20 tripropylene glycol diacrylate. In a preferred embodiment, the composition photoinitiator also includes 1-hydroxycyclohexyl phenyl ketone.

The above brief description as well as further
25 objects, features and advantages of the methods, apparatus and compositions of the present invention will be more fully appreciated by reference to the following detailed description of presently preferred but
nonetheless illustrative embodiments in accordance with
30 the present invention when taken in conjunction with the accompanying drawings in which:

Fig. 1 is a perspective view of an apparatus for
producing a plastic lens according to the present
35 invention;

Fig. 2 is a cross-sectional view of the apparatus of the present invention taken along line 2-2 of Fig. 1;

Fig. 3 is a cross-sectional view of the apparatus of the present invention taken along line 3-3 of Fig. 2;

Fig. 4 is a detail view of a component of the apparatus of the present invention;

Fig. 5 is a detail view of a component of the apparatus of the present invention;

Fig. 6 is a cross-sectional view of a lens cell for use in the apparatus of the present invention;

Fig. 7 is a perspective view of an apparatus for producing a plastic lens according to the present invention; and

Fig. 8 is a perspective view of an apparatus for producing a plastic lens according to the present invention.

Fig. 9 is a schematic block diagram of an alternate process and system for making and postcuring a plastic lens.

While various aspects of the present invention are hereinafter illustrated and described as being particularly adapted for the production of a plastic lens for use in eyeglasses, it is to be understood that lenses for other uses can also be produced, such as safety glasses as well as lenses having high quality optical use for instrument sightings, photography and light filtration.

-6-

Therefore, the present invention is not to be limited only to the embodiments illustrated in the drawings, because the drawings are merely illustrative of the wide variety of specific embodiments of the present invention.

Referring now to Fig. 1, a plastic lens curing chamber of the present invention is generally indicated by the reference numeral 10. The lens curing chamber 10 communicates through a plurality of pipes 12 with an air source (not shown), the purpose of which will be discussed below.

As shown in Fig. 2, the plastic lens curing chamber 10 may include an upper lamp chamber 14, an irradiation chamber 16, and a lower lamp chamber 18. The upper lamp chamber 14 may be separated from the irradiation chamber 16 by a plate 20. The lower lamp chamber may be separated from the irradiation chamber 16 by a plate 22. The upper lamp chamber 14, the irradiation chamber 16, and the lower lamp chamber 18 may be isolated from ambient air by means of upper lamp chamber doors 24, irradiation chamber doors 26, and lower lamp chamber doors 28, respectively. While the upper lamp chamber doors 24, the irradiation chamber doors 26 and the lower lamp chamber doors 28 are shown in Fig. 1 as including two corresponding door members, those of ordinary skill in the art will recognize that the doors 24, 26 and 28 may comprise a single door member. The upper lamp chamber doors 24, the irradiation chamber doors 26 and the lower lamp chamber doors 28 may be slidably mounted in guides 30. As shown in Fig. 2, vents 32 may communicate with upper lamp chamber 14 and lower lamp chamber 18 by way of corresponding vent chambers 34 and openings 36 disposed in plate 20 and

plate 22. Each vent 32 may be shielded by a vent cover 38.

As shown in Fig. 3, vents 33 may be disposed in the irradiation chamber doors 26 and communicate with irradiation chamber 16. Each vent 33 may be shielded by a vent cover 35.

As shown in Figs. 2 and 3, a plurality of light generating devices or lamps 40 may be disposed within each of upper lamp chamber 14 and lower lamp chamber 18. Preferably, upper lamp chamber 14 and lower lamp chamber 18 each include three lamps 40 that are arranged in a triangular fashion in which the lamps 40 in the upper lamp chamber 14 are disposed with the point of the triangle pointing upwards whereas the lamps 40 in the lower lamp chamber 18 are disposed with the point of the triangle pointing downward. The lamps 40, preferably, generate ultraviolet light having a wavelength in the range of approximately 300 nm to 400 nm since the effective wavelength spectrum for curing the lens forming material lies in the 300 nm to 400 nm region. The lamps 40 may be supported by and electrically connected to suitable fixtures 42.

An exhaust fan 44 may communicate with upper lamp chamber 14 while an exhaust fan 46 may communicate with lower lamp chamber 18.

As noted above, the upper lamp chamber 14 may be separated from the irradiation chamber 16 by plate 20. Similarly, lower lamp chamber 18 may be separated from the irradiation chamber 16 by plate 22. The plates 20 and 22 may include apertures 48 and 50, respectively through which the light generated by lamps 40 may be directed so as to impinge upon a lens cell 52 (shown in

phantom in Fig. 2). The diameter of the lens cell 52 according to the present invention, preferably, is approximately 74 mm. The apertures 48 and 50 preferably range from about 70 mm to about 140 mm. An upper light filter 54 rests upon plate 20 while a lower light filter 56 rests upon plate 22 or is supported by brackets 57. The upper light filter 54 and lower light filter 56 are shown in Fig. 2 as being comprised of a single filter member, however, those of ordinary skill in the art will recognize that each of the upper light filter 54 and lower light filter 56 may be comprised of two filter members. The components of upper light filter 54 and lower light filter 56 preferably are modified depending upon the characteristics of the lens to be molded. For instance, in a preferred embodiment for making negative lenses, the upper light filter 54 includes a plate of Pyrex glass that is frosted on both sides resting upon a plate of clear Pyrex glass. The lower light filter 56 includes a plate of Pyrex glass frosted on one side resting upon a plate of clear Pyrex glass with a device for reducing the intensity of ultraviolet light incident upon the center portion in relation to the edge portion of the lens being disposed between the plate of frosted Pyrex and the plate of clear Pyrex glass.

25

Conversely, in a preferred arrangement for producing positive lenses, the upper light filter 54 includes a plate of Pyrex glass frosted on one or both sides and a plate of clear Pyrex glass resting upon the plate of frosted Pyrex glass with a device for reducing the intensity of ultraviolet light incident upon the edge portion in relation to the center portion of the lens being disposed between the plate of clear Pyrex glass and the plate of frosted Pyrex glass. The lower light filter 56 includes a plate of clear Pyrex glass frosted on one side resting upon a plate of clear Pyrex glass

with a device for reducing the intensity of ultraviolet light incident upon the edge portion in relation to the center portion of the lens being disposed between the plates of clear Pyrex glass. In this arrangement, in
5 place of a device for reducing the relative intensity of ultraviolet light incident upon the edge portion of the lens, the diameter of the aperture 50 can be reduced to achieve the same result, i.e. to reduce the relative
10 intensity of ultraviolet light incident upon the edge portion of the lens.

It will be apparent to those skilled in the art that each filter 54 or 56 could comprise a plurality of filter members or comprise any other means or device effective
15 to reduce the light to its desired intensity, to diffuse the light and/or to create a light intensity gradient across the lens cell 52.

Preferably, the upper light filter 54 or the lower
20 light filter 56 each comprise at least one plate of Pyrex glass having at least one frosted surface. Also, either or both of the upper light filter 54 and the lower light filter 56 may include more than one plate of Pyrex glass each frosted on one or both surfaces, and/or one or more
25 sheets of tracing paper. After passing through frosted Pyrex glass, the ultraviolet light is believed to have no sharp intensity discontinuities which is believed to lead to a reduction in optical distortions in the finished lens. Those of ordinary skill in the art will recognize
30 that other means may be used to diffuse the ultraviolet light so that it has no sharp intensity discontinuities.

Disposed within the irradiation chamber 16 are a
left stage 58, a center stage 60, and a right stage 62,
35 each of which includes a plurality of steps 64. The left stage 58 and center stage 60 define a left irradiation

-10-

chamber 66 while the right stage 62 and center stage 60 define a right irradiation chamber 68. A cell holder 70, shown in phantom in Fig. 2 and in detail in Fig. 4, may be disposed within each of left irradiation chamber 66 and right irradiation chamber 68. The cell holder 70 includes a peripheral step 72 that is designed to allow a cell holder 70 to be supported upon complementary steps 64 of left stage 58 and center stage 60, and center stage 60 and right stage 62, respectively. As shown in Fig. 4, each cell holder 70 also includes a central bore 74 to allow the passage therethrough of ultraviolet light from the lamps 40 and an annular step 76 which is designed to support a lens cell 52 in a manner described below.

15

As shown in Fig. 6, each lens cell 52 includes opposed mold members 78, separated by an annular gasket 80 to define a lens molding cavity 82. The opposed mold members 78 and the annular gasket 80 may be selected in a manner to produce a lens having a desired diopter.

20

The mold members 78, preferably, are formed of any suitable material that will permit rays of ultraviolet light to pass therethrough. The mold members 78, preferably, are formed of glass. Each mold member 78 has an outer peripheral surface 84 and a pair of opposed surfaces 86 and 88 with the surfaces 86 and 88 being precision ground. Preferably the mold members 78 have desirable ultraviolet light transmission characteristics and both the casting surface 86 and non-casting surface 88 preferably have no surface aberrations, waves, scratches or other defects as these may be reproduced in the finished lens.

35

As noted above, the mold members 78 are adapted to be held in spaced apart relation to define a lens molding cavity 82 between the facing surfaces 86 thereof. The mold members 78 are held in a spaced apart relation by a T-shaped flexible annular gasket 80 that seals the lens molding cavity 82 from the exterior of the mold members 78. In use, the gasket 80 is supported on the annular step 76 of the cell holder 70.

In this manner, in the embodiment of the present invention that is illustrated in Fig. 6 the upper or back mold member 90 has a convex inner surface 86 while the lower or front mold member 92 has a concave inner surface 86 so that the resulting lens molding cavity 82 is shaped to form a lens with a desired configuration. Thus, by selecting the mold members 78 with a desired surface 86, lenses with different characteristics, such as focal lengths, may be made by the apparatus 10. Such techniques are well known to those skilled in the art, and will therefore not be further discussed.

Rays of ultraviolet light emanating from lamps 40 pass through the mold members 78 and act on a lens forming material disposed in the mold cavity 82 in a manner discussed below so as to form a lens. As noted above, the rays of ultraviolet light pass through a suitable filter 54 or 56 to impinge upon the lens cell 52.

The mold members 78, preferably, are formed from a material that will not allow ultraviolet radiation having a wavelength below approximately 300 nm to pass therethrough. Suitable materials are Schott Crown, S-1 or S-3 glass manufactured and sold by Schott Optical Glass Inc., of Duryea, Pennsylvania or Corning 8092 glass sold by Corning Glass of Corning, New York.

-12-

The annular gasket 80 may be formed of vinyl material that exhibits good lip finish and maintains sufficient flexibility at conditions throughout the lens curing process. In a preferred embodiment, the annular gasket 80 is formed of silicone rubber material such as GE SE6035 which is commercially available from General Electric. In another preferred embodiment, the annular gasket 80 is formed of copolymers of ethylene and vinyl acetate which are commercially available from E. I. DuPont de Nemours & Co. under the trade name ELVAX®. Preferred ELVAX® resins are ELVAX® 350 having a melt index of 17.3-20.9 dg/min and a vinyl acetate content of 24.3-25.7 wt. %, ELVAX® 250 having a melt index of 22.0-28.0 dg/min and a vinyl acetate content of 27.2-28.8 wt. %, ELVAX® 240 having a melt index of 38.0-48.0 dg/min and a vinyl acetate content of 27.2-28.8 wt. %, and ELVAX® 150 having a melt index of 38.0-48.0 dg/min and a vinyl acetate content of 32.0-34.0 wt. %. Regardless of the particular material, the gaskets 80 may be prepared by conventional injection molding or compression molding techniques which are well-known by those of ordinary skill in the art.

As shown in phantom in Fig. 2, in section in Fig. 3, and in detail in Fig. 5, an upper and lower air distribution device 94 is disposed in each of left irradiation chamber 66 and right irradiation chamber 68. Each air distribution device 94 is connected to a pipe 12. As shown in Fig. 5, each air distribution device 94 includes a plenum portion 95 and a cylindrical opening 96 having orifices 98 disposed therein to allow for the expulsion of air from the air distribution device 94. The diameter of the orifices 98 varies around the circumference of cylindrical opening 96 preferably reaching a maximum when directly opposite the plenum portion 95 of air distribution device 94 and preferably

reaching a minimum immediately adjacent the plenum
portion 95. In addition, the orifices 98 are designed to
blow air toward a lens cell 52 that may be disposed in a
lens cell holder 70 and installed in left irradiation
5 chamber 66 or right irradiation chamber 68.

In operation, the apparatus of the present invention
may be appropriately configured for the production of
positive lenses which are relatively thick at the center
10 or negative lenses which are relatively thick at the
edge. To reduce the likelihood of premature release, the
relatively thick portions of a lens preferably are
polymerized at a faster rate than the relatively thin
portions of a lens.

15

The rate of polymerization taking place at various
portions of a lens may be controlled by varying the
relative intensity of ultraviolet light incident upon
particular portions of a lens. The rate of
20 polymerization taking place at various portions of a lens
may also be controlled by directing air across the mold
members 78 to cool the lens cell 52.

For positive lenses the intensity of incident
25 ultraviolet light, preferably, is reduced at the edge
portion of the lens so that the thicker center portion of
the lens polymerizes faster than the thinner edge portion
of the lens. Conversely, for a negative lens, the
intensity of incident ultraviolet light, preferably, is
30 reduced at the center portion of the lens so that the
thicker edge portion of the lens polymerizes faster than
the thinner center portion of the lens. For either a
positive lens or a negative lens, air may be directed
across the faces of the mold members 78 to cool the lens
35 cell 52. As the overall intensity of incident
ultraviolet light is increased, more cooling is needed

which can be accomplished by either or both of increasing the velocity of the air and reducing the temperature of the air.

5 It is well known by those of ordinary skill in the art that lens forming materials having utility in the present invention tend to shrink as they cure. If the relatively thin portion of a lens is allowed to polymerize before the relatively thick portion, the
10 relatively thin portion will tend to be rigid at the time the relatively thick portion cures and shrinks and the lens will either release prematurely from or crack the mold members 78. Accordingly, when the relative intensity of ultraviolet light incident upon the edge
15 portion of a positive lens is reduced relative to the center portion, the center portion polymerizes faster and shrinks before the edge portion is rigid so that the shrinkage is more uniform. Conversely, when the relative intensity of ultraviolet light incident upon the center
20 portion of a negative lens is reduced relative to the edge portion, the edge portion polymerizes faster and shrinks before the center becomes rigid so that the shrinkage is more uniform.

25 According to the present invention, the variation of the relative intensity of ultraviolet light incident upon a lens may be accomplished in a variety of ways. According to one method, in the case of a positive lens, a ring of opaque material may be placed between the
30 lamps 40 and the lens cell 52 so that the incident ultraviolet light falls mainly on the thicker center portion of the lens. Conversely, for a negative lens, a disk of opaque material may be placed between the lamps 40 and the lens cell 52 so that the incident
35 ultraviolet light falls mainly on the edge portion of the lens.

According to another method, in the case of a negative lens, a sheet material having a variable degree of opacity ranging from opaque at a central portion to transparent at a radial outer portion is disposed between the lamps 40 and the lens cell 52. Conversely, for a positive lens, a sheet material having a variable degree of opacity ranging from transparent at a central portion to opaque at a radial outer portion is disposed between the lamps 40 and the lens cell 52.

10

According to still another method, a plurality of ultraviolet-light absorbing geometric or random shapes are printed and arranged on a sheet material. In the case of a positive lens, the density of the shapes is greatest at a radial outer portion while the density of the shapes is smallest at a central portion of the pattern. Conversely, in the case of a negative lens, the density of the shapes is smallest at a radial outer portion while the density of the shapes is greatest at a central portion of the pattern.

15
20

Those of ordinary skill in the art will recognize that there are a wide variety of techniques other than those enumerated above for varying the intensity of the ultraviolet light incident upon the opposed mold members 78.

25

The intensity of the incident light has been measured and determined to be approximately 3.0 to 5.0 milliwatts per square centimeter (mW/cm^2) prior to passing through either the upper light filter 54 or the lower light filter 56 and the total intensity at the thickest part of the lens ranges from 0.6 to 2.0 mW/cm^2 while the intensity at the thinnest portion of the lens ranges from 0.1 to 1.5 mW/cm^2 . It has also been determined that the overall light intensity incident on the lens cell 52 has

30
35

-16-

less of an impact on the final product than the relative light intensity incident upon the thick or thin portions of the lens so long as the lens cell 52 is sufficiently cooled to reduce the polymerization rate to an acceptable
5 level.

According to the present invention, it has been determined that the finished power of an ultraviolet light polymerized lens may be controlled by manipulating
10 the distribution of the incident ultraviolet light striking the opposed mold members 78. For instance, for an identical combination of mold members 78 and gasket 80, the focusing power of the produced lens may be increased or decreased by changing the pattern of
15 intensity of ultraviolet light across the lens mold cavity 82 or the faces of the opposed mold members 78.

As the lens forming material begins to cure, it passes through a gel state, the pattern of which within
20 the lens cell 52 leads to the proper distribution of internal stresses generated later in the cure when the lens forming material begins to shrink.

As the lens forming material shrinks during the
25 cure, the opposed mold members 78 will flex as a result of the different amounts of shrinkage between the relatively thick and the relatively thin portions of the lens. When a negative lens, for example, is cured, the upper or back mold member 90 will flatten and the lower
30 or front mold member 92 will steepen with most of the flexing occurring in the lower or front mold member 92. Conversely, with a positive lens, the upper or back mold member 90 will steepen and the lower or front mold member 92 will flatten with most of the flexing occurring in the
35 upper or back mold member 90.

-17-

By varying the intensity of the ultraviolet light between the relatively thin and the relatively thick portions of the lens in the lens forming cavity 82, it is possible to create more or less total flexing. Those light conditions which result in less flexing will minimize the possibility of premature release.

The initial curvature of the opposed mold members 78 and the center thickness of the lens produced can be used to compute the theoretical or predicted power of the lens. The ultraviolet light conditions can be manipulated to alter the power of the lens to be more or less than predicted. For example, when a disk of opaque material is positioned between the lower lamp chamber 18 and the lens cell 52, less total flexure is observed. The greater the diameter of the disk of opaque material, the more negative (-) power the resultant lens will exhibit.

When the lenses cured by the ultraviolet light are removed from the opposed mold members 78, they are under a stressed condition. It has been determined that the power of the lens can be brought to a final resting power, by subjecting the lenses to a post-curing heat treatment to relieve the internal stresses developed during the cure and cause the curvature of the front and the back of the lens to shift. Typically, the lenses are cured by the ultraviolet light in about 10-30 minutes (preferably about 15 minutes). The post-curing heat treatment is conducted at approximately 85-120°C for approximately 5-15 minutes. Preferably, the post-curing heat treatment is conducted at 100-110°C for approximately 10 minutes. Prior to the post-cure, the lenses generally have a lower power than the final resting power. The post-curing heat treatment reduces yellowing of the lens and reduces stress in the lens to

-18-

alter the power thereof to a final power. The post-curing heat treatment can be conducted in a conventional convection oven or any other suitable device.

5

According to the present invention, the ultraviolet lamps 40 preferably are maintained at a temperature at which the lamps 40 deliver maximum output. The lamps 40, preferably, are cooled because the intensity of the light produced by the lamps 40 fluctuates when the lamps 40 are allowed to overheat. In the apparatus of the present invention depicted in Fig. 2, the cooling of the lamps 40 is accomplished by sucking ambient air into the upper lamp chamber 14 and lower lamp chamber 18 through vent 10 32, vent chambers 34 and openings 36 by means of exhaust fans 44 and 46, respectively. Excessive cooling of the lamps 40 should be avoided, however, as the intensity of the light produced by the lamps 40 is reduced when the lamps 40 are cooled to an excessive degree.

15
20

As noted above, according to the present invention, the lens cell 52, preferably, is cooled during curing of the lens forming material as the overall intensity of the incident ultraviolet light is increased. Cooling of the lens cell 52 generally reduces the likelihood of premature release by slowing the reaction and improving adhesion. There are also improvements in the optical quality, stress characteristics and impact resistance of the lens. Cooling of the lens cell 52, preferably, is accomplished by blowing air across the lens cell 52. The air preferably has a temperature ranging between 15 and 85°F (about -9.4°C to 29.4°C) to allow for a curing time of between 30 and 10 minutes. The air distribution devices 94 depicted in Fig. 5 have been found to be particularly advantageous as they are specifically designed to direct air directly across the surface of the

25
30
35

-19-

opposed mold members 78. After passing across the surface of the opposed mold members 78, the air emanating from the air distribution devices 94 is vented through vents 33. Alternately the air emanating from the air distribution devices 94 may be recycled back to an air cooler 312, such as is shown in Figure 9.

The lens cell 52 may also be cooled by disposing the lens cell in a liquid cooling bath.

10

The opposed mold members 78, preferably, are thoroughly cleaned between each curing run as any dirt or other impurity on the mold members 78 may cause premature release. The mold members 78 are cleaned by any conventional means well known to those of ordinary skill in the art such as with a domestic cleaning product i.e. Mr. Clean® available from Procter and Gamble. Those of ordinary skill in the art will recognize, however, that many other techniques may also be used for cleaning the mold members 78.

15
20

Yellowing of the finished lens may be related to the monomer composition, the identity of the photoinitiator and the concentration of the photoinitiator.

25

When casting a lens, particularly a positive lens that is thick in the center, cracking may be a problem. Addition polymerization reactions, including photochemical addition polymerization reactions, are exothermic. During the process, a large temperature gradient may build up and the resulting stress may cause the lens to crack.

30

When the polymerization reaction proceeds too rapidly, heat buildup inside the system which leads to cracking is inevitable. The likelihood of cracking

35

-20-

increases as the temperature difference between the center of the lens forming material and room temperature increases. During the polymerization process, several forces tending to crack the lens, such as shrinkage, 5 adhesion, and thermal gradients, are at work. Other forces tending to crack the lens may occur when the irradiation is stopped and the lens is cooled, especially if the lens cell 52 is allowed to cool too quickly.

10 The formation of optical distortions usually occurs during the early stages of the polymerization reaction during the transformation of the lens forming composition from the liquid to the gel state. Once patterns leading to optical distortions form they are difficult to 15 eliminate. When gelation occurs there is a rapid temperature rise. The exothermic polymerization step causes a temperature increase, which in turn causes an increase in the rate of polymerization, which causes a further increase in temperature. If the heat exchange 20 with the surroundings is not sufficient enough there will be a runaway situation that leads to premature release, the appearance of thermally caused striations and even breakage. Since the rate of polymerization increases rapidly at the gelation point, this is an important phase 25 of the reaction.

Accordingly, it is preferred that the reaction process be smooth and not too fast but not too slow. Heat is preferably not generated by the process so fast 30 that it cannot be exchanged with the surroundings. The incident ultraviolet light intensity preferably is adjusted to allow the reaction to proceed at a desired rate. It is also preferred that the seal between the annular gasket 80 and the opposed mold members 78 is as 35 complete as possible.

Factors that have been found to lead to the production of lenses that are free from optical distortions are (1) achieving a good seal between the annular gasket 80 and the opposed mold members 78; (2) using mold members 78 having surfaces that are free from defects; (3) using a formulation having an appropriate type and concentration of photoinitiator that will produce a reasonable rate of temperature rise; and (4) using a homogeneous formulation. Preferably, these conditions are optimized.

Premature release of the lens from the mold will result in an incompletely cured lens and the production of lens defects. Factors that contribute to premature release are (1) a poorly assembled lens cell 52; (2) the presence of air bubbles around the sample edges; (3) imperfection in gasket lip or mold edge; (4) inappropriate formulation; (5) uncontrolled temperature rise; and (6) high or nonuniform shrinkage. Preferably, these conditions are minimized.

Premature release may also occur when the opposed mold members 78 are held too rigidly by the annular gasket 80. Preferably, there is sufficient flexibility in the annular gasket 80 to permit the opposed mold members 78 to follow the lens as it shrinks. Indeed, the lens must be allowed to shrink in diameter slightly as well as in thickness. The use of an annular gasket 80 that has a reduced degree of stickiness with the lens during and after curing is therefore desirable.

In a preferred technique for filling the lens molding cavity 82, the annular gasket 80 is placed on a concave or front mold member 92 and a convex or back mold member 90 is moved into place. The annular gasket 80 is then pulled away from the edge of the back mold member 90

-22-

at the uppermost point and a lens forming composition is injected into the lens molding cavity 82 until a small amount of the lens forming composition is forced out around the edge. The excess is then removed, preferably, by vacuum. Excess liquid that is not removed could spill over the face of the back mold member 90 and cause optical distortion in the finished lens.

Despite the above problems, the advantages offered by the radiation cured lens molding system clearly outweigh the disadvantages. The advantages of a radiation cured system include a significant reduction in energy requirements, curing time and other problems normally associated with conventional thermal systems.

According to the present invention, the lens forming material can comprise any suitable liquid monomer or monomer mixture and any suitable photosensitive initiator. The lens forming material, preferably, does not include any component, other than a photoinitiator, that absorbs ultraviolet light having a wavelength in the range of 300 to 400 nm. The liquid lens forming material, preferably, is filtered for quality control and placed in the lens molding cavity 82 by pulling the annular gasket 80 away from one of the opposed mold members 78 and injecting the liquid lens forming material into the lens molding cavity 82. Once the lens molding cavity 82 is filled with such material, the annular gasket 80 is replaced into its sealing relation with the opposed mold members 78. The material can then be irradiated with ultraviolet light in the manner described above for a time period that is necessary to cure the lens forming material, preferably approximately 10 to approximately 30 minutes. The ultraviolet light entering the lens molding cavity 82 preferably has a wavelength in

-23-

the range of approximately 300 nm. to approximately 400 nm.

Those skilled in the art will recognize that once
5 the cured lens is removed from the lens molding cavity 82
by disassembling the opposed mold members 78, the lens
can be further processed in a conventional manner, such
as by grinding its peripheral edge.

10 According to the present invention a polymerizable
lens forming composition comprises an aromatic-containing
bis(allyl carbonate)-functional monomer and at least one
polyethylenic-functional monomer containing two
15 ethylenically unsaturated groups selected from acrylyl
and methacrylyl. In a preferred embodiment, the
composition further comprises a suitable photoinitiator.
In other preferred embodiments, the composition may
include one or more polyethylenic-functional monomers
containing three ethylenically unsaturated groups
20 selected from acrylyl and methacrylyl, and a dye.

Aromatic-containing bis(allyl carbonate)-functional
monomers which can be utilized in the practice of the
present invention are bis(allyl carbonates) of dihydroxy
25 aromatic-containing material. The dihydroxy
aromatic-containing material from which the monomer is
derived may be one or more dihydroxy aromatic-containing
compounds. Preferably the hydroxyl groups are attached
directly to nuclear aromatic carbon atoms of the
30 dihydroxy aromatic-containing compounds. The monomers
are themselves known and can be prepared by procedures
well known in the art.

The aromatic-containing bis(allyl carbonate)-
35 functional monomers can be represented by the formula:

-24-

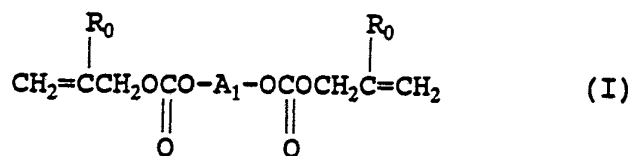

5

in which A_1 is the divalent radical derived from the dihydroxy aromatic-containing material and each R_0 is independently hydrogen, halo, or a C_1 - C_4 alkyl group. The alkyl group is usually methyl or ethyl. Examples of R_0 include hydrogen, chloro, bromo, fluoro, methyl, ethyl, n-propyl, isopropyl and n-butyl. Most commonly R_0 is hydrogen or methyl; hydrogen is preferred. A subclass of the divalent radical A_1 which is of particular usefulness is represented by the formula:

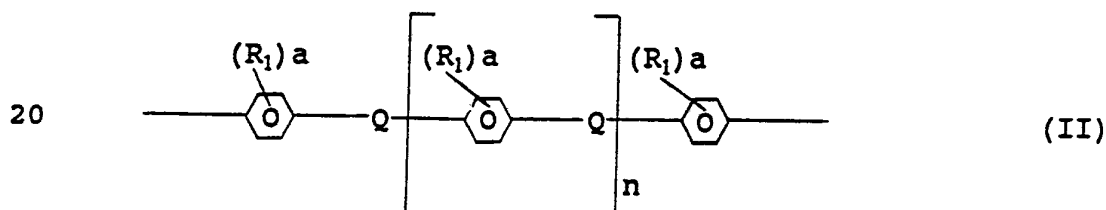

in which each R_1 is independently alkyl containing from 1 to about 4 carbon atoms, phenyl, or halo; the average value of each a is independently in the range of from 0 to 4; each Q is independently oxy, sulfonyl, alkanediyl having from 2 to about 4 carbon atoms, or alkylidene having from 1 to about 4 carbon atoms; and the average value of n is in the range of from 0 to about 3. Preferably Q is methylethylidene, viz., isopropylidene.

Preferably the value of n is zero, in which case A_1 is represented by the formula:

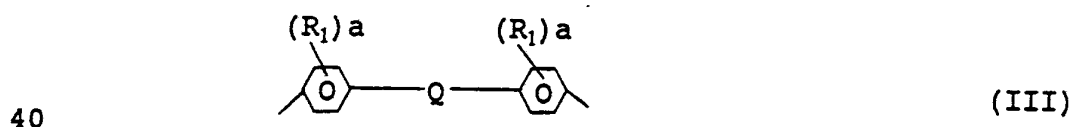

40

-25-

in which each R_1 , each a , and Q are as discussed in respect of Formula II. Preferably the two free bonds are both in the ortho or para positions. The para positions are especially preferred.

5

The dihydroxy aromatic-containing compounds from which A_1 is derived may also be polyol-functional chain extended compounds. Examples of such compounds include alkaline oxide extended bisphenols. Typically the alkaline oxide employed is ethylene oxide, propylene oxide, or mixtures thereof. By way of exemplification, when para, para-bisphenols are chain extended with ethylene oxide, the bivalent radical A_1 may often be represented by the formula:

15

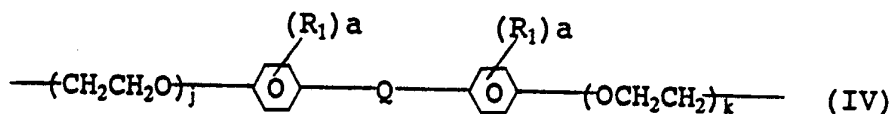

20

where each R_1 , each a , and Q are as discussed in respect of Formula II, and the average values of j and k are each independently in the range of from about 1 to about 4.

25

The preferred aromatic-containing bis(allyl carbonate)-functional monomer is represented by the formula:

30

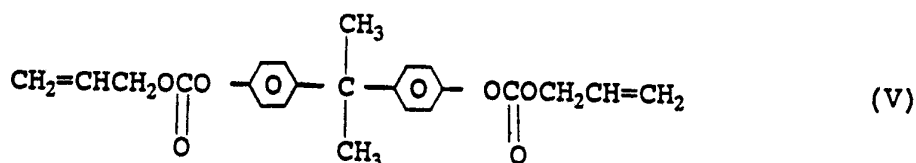

35

and is commonly known as bisphenol A bis(allyl carbonate).

A wide variety of compounds may be used as the polyethylenic functional monomer containing two or three

40

-26-

ethylenically unsaturated groups. The preferred polyethylenic functional compounds containing two or three ethylenically unsaturated groups may be generally described as the acrylic acid esters and the methacrylic acid esters of aliphatic polyhydric alcohols, such as, for example, the di- and triacrylates and the di- and trimethacrylates of ethylene glycol, triethylene glycol, tetraethylene glycol, tetramethylene glycol, glycidyl, diethyleneglycol, butyleneglycol, propyleneglycol, pentanediol, hexanediol, trimethylolpropane, and tripropyleneglycol. Examples of specific suitable polyethylenic - functional monomers containing two or three ethylenically unsaturated groups include trimethylolpropanetriacrylate (TMPTA), tetraethylene glycol diacrylate (TEGDA), tripropylene glycol diacrylate (TRPGDA), 1,6 hexanedioldimethacrylate (HDDMA), and hexanedioldiacrylate (HDDA).

In general, a photoinitiator for initiating the polymerization of the lens forming composition of the present invention, preferably, exhibits an ultraviolet absorption spectrum over the 300-400 nm range. High absorptivity of a photoinitiator in this range, however, is not desirable, especially when casting a thick lens. The following are examples of illustrative photoinitiator compounds within the scope of the invention: methyl benzoylformate, 2-hydroxy-2-methyl-1-phenylpropan-1-one, 1-hydroxycyclohexyl phenyl ketone, 2,2-di-sec-butoxyacetophenone, 2,2-diethoxyacetophenone, 2,2-diethoxy-2-phenyl-acetophenone, 2,2-dimethoxy-2-phenyl-acetophenone, benzoin methyl ether, benzoin isobutyl ether, benzoin, benzil, benzyl disulfide, 2,4-dihydroxybenzophenone, benzylideneacetophenone, benzophenone and acetophenone. Preferred photoinitiator compounds are 1-hydroxycyclohexyl phenyl ketone (which is commercially available from Ciba-Geigy as Irgacure 184),

-27-

methyl benzoylformate (which is commercially available from Polysciences, Inc.), or mixtures thereof.

Methyl benzoylformate is a generally preferred
5 photoinitiator because it tends to provide a slower rate
of polymerization. The slower rate of polymerization
tends to prevent excessive heat buildup (and resultant
cracking of the lens) during polymerization. In
addition, it is relatively easy to mix liquid methyl
10 benzoylformate (which is liquid at ambient temperatures)
with many acrylates, diacrylates, and allyl carbonate
compounds to form a lens forming composition. The lenses
produced with the methyl benzoylformate photoinitiator
tend to exhibit more favorable stress patterns and
15 uniformity.

A strongly absorbing photoinitiator will absorb most
of the incident light in the first millimeter of lens
thickness, causing rapid polymerization in that region.
20 The remaining light will produce a much lower rate of
polymerization below this depth and will result in a lens
that has visible distortions. An ideal photoinitiator
will exhibit high activity, but will have a lower
extinction coefficient in the useful range. A lower
25 extinction coefficient of photoinitiators at longer
wavelengths tends to allow the ultraviolet radiation to
penetrate deeper into the reaction system. This deeper
penetration of the ultraviolet radiation allows
photoinitiator radicals to form uniformly throughout the
30 sample and provide excellent overall cure. Since the
sample can be irradiated from both top and bottom, a
system in which appreciable light reaches the center of
the thickest portion of the lens is preferred. The
photoinitiator solubility and compatibility with the
35 monomer system is also an important requirement.

-28-

An additional consideration is the effect of the photoinitiator fragments in the finished polymer. Some photoinitiators generate fragments that impart a yellow color to the finished lens. Although such lenses
5 actually absorb very little visible light, they are cosmetically undesirable.

Photoinitiators are often very system specific so that photoinitiators that are efficient in one system may
10 function poorly in another. In addition, the initiator concentration to a large extent is dependent on the incident light intensity and the monomer composition. The identity of the initiator and its concentration are important for any particular formulation. A
15 concentration of initiator that is too high tends to lead to cracking and yellowing of the lens. Concentrations of initiator that are too low tend to lead to incomplete polymerization and a soft material.

20 Dyes and/or pigments are optional materials that may be present when high transmission of light is not necessary.

The listing of optional ingredients discussed above
25 is by no means exhaustive. These and other ingredients may be employed in their customary amounts for their customary purposes so long as they do not seriously interfere with good polymer formulating practice.

30 According to a preferred embodiment of the present invention, the preferred aromatic-containing bis(allyl carbonate) functional monomer, bisphenol A bis(allyl carbonate) is admixed with one or more faster reacting polyethylenic functional monomers containing two acrylate
35 or methacrylate groups such as 1,6 hexanediol dimethacrylate (HDDMA), 1,6 hexanediol diacrylate (HDDA),

tetraethylene glycol diacrylate (TTEGDA), and tripropylene glycol diacrylate (TRPGDA) and optionally a polyethylenic functional monomer containing three acrylate groups such as trimethylolpropane triacrylate (TMPTA). Generally, compounds containing acrylate groups polymerize much faster than those containing allyl groups.

The lamps 40 generate an intensity at the lamp surface of approximately 4.0 to 7.0 mW/cm² of ultraviolet light having wavelengths between 300 and 400 nm, which light is very uniformly distributed without any sharp discontinuities throughout the reaction process. Such bulbs are commercially available from Sylvania under the trade designation Sylvania Fluorescent (F158T/2052) or Sylvania Fluorescent (F258T8/350BL/18") GTE. As noted above, ultraviolet light having wavelengths between 300 and 400 nm is preferred because the photoinitiators according to the present invention, preferably, absorb most efficiently at this wavelength and the mold members 78, preferably, allow maximum transmission at this wavelength.

It is preferred that there be no sharp intensity gradients of ultraviolet radiation either horizontally or vertically through the lens composition during the curing process. Sharp intensity gradients through the lens may lead to defects in the finished lens.

According to one embodiment of the present invention, the liquid lens forming composition includes bisphenol A bis(allyl carbonate) in place of DEG-BAC. The bisphenol A bis(allyl-carbonate) monomer has a higher refractive index than DEG-BAC which allows the production of thinner lenses which is important with relatively thick positive or negative lenses. The

-30-

bisphenol A bis(allyl-carbonate) monomer is commercially available from PPG Industries under the trade name HIRI I or CR-73. Lenses made from this product sometimes have a very slight, barely detectable, degree of yellowing. A
5 small amount of a blue dye consisting of 9,
10-anthracenedione, 1-hydroxy-4-[(4-methylphenyl)amino]
available as Thermoplast Blue 684 from BASF Wyandotte Corp. is preferably added to the composition to
counteract the yellowing. In addition, the yellowing
10 tends to disappear if the lens is subjected to the
above-described post-cure heat treatment. Moreover, if
not post-cured the yellowing tends to disappear at
ambient temperature after approximately 2 months.

15 According to a preferred embodiment, the composition
of the present invention includes (a) bisphenol
A-bis(allyl carbonate); (b) at least one of HDDMA, TTEGDA
and TRPGDA; and (c) a photoinitiator. According to this
embodiment the composition may also include one or both
20 of TMPTA and a dye.

According to another preferred embodiment, the
composition of the present invention includes (a) up to
70 percent by weight of bisphenol A bis(allyl carbonate);
25 (b) up to 100 percent by weight of HDDMA; (c) up to 100
percent by weight of TTEGDA; (d) up to 100 percent by
weight of TRPGDA; and (e) up to 100 percent by weight of
TMPTA. Preferably, the composition further comprises (f)
up to about 1.0 percent by weight of
30 1-hydroxycyclohexylphenyl ketone; and (g) up to about 1.2
percent by weight of methyl benzoylformate. Preferably
the composition further comprises (h) up to about 1.0
parts per million (ppm) of 9,10-anthracenedione,
1-hydroxy-4-[(4-methylphenyl)amino].

35

-31-

According to still another preferred embodiment, the composition of the present invention includes (a) about 15.0 to about 25.0 percent by weight of bisphenol A bis(allyl-carbonate); (b) about 8.0 to about 14.0 percent by weight of HDDMA; (c) about 15.0 to about 25.0 percent by weight of TTEGDA; (d) about 17.0 to about 37.0 percent by weight of TRPGDA; and (e) about 15.0 to about 25.0 percent by weight of TMPTA. The composition may also include (f) about 0.003 to about 0.04 percent by weight of 1-hydroxycyclohexylphenyl ketone, (g) about 0.015 to about 0.05 percent by weight of methyl benzoylformate, and (h) about 0.16 to about 0.20 ppm of 9,10-anthracenedione, 1-hydroxy-4-[(4-methylphenyl)amino].

15

According to a further preferred embodiment, the composition includes 17.0% by weight of bisphenol A bis(allyl carbonate), 10.0% by weight of HDDMA, 21.0% by weight of TTEGDA, 32.0% by weight of TRPGDA, and 20.0% by weight of TMPTA. The composition may also include 0.0095% by weight of 1-hydroxycyclohexylphenyl ketone, 0.0356% by weight of methyl benzoylformate, and 0.16 ppm of 9,10-anthracenedione, 1-hydroxy-4-[(4-methylphenyl)amino].

20

As discussed above, bisphenol A bis(allyl carbonate) has a higher refractive index than DEG-BAC and thus allows the production of thinner lenses when compared to DEG-BAC lenses.

25

TTEGDA, available from Sartomer and Radcure, is a diacrylate monomer that, preferably, is included in the composition because it is a fast polymerizing monomer that reduces yellowing and yields a very clear product. If too much TTEGDA is included in the most preferred composition, i.e. greater than about 25% by weight,

30

however, the finished lens may be prone to cracking and may be too flexible as this material softens at temperatures above 40°C. If TTEGDA is excluded altogether, the finished lens may to be brittle.

5

HDDMA, available from Sartomer, is a dimethacrylate monomer that has a very stiff backbone between the two methacrylate groups. HDDMA, preferably, is included in the composition because it yields a stiffer polymer and
10 increases the hardness and strength of the finished lens. This material is quite compatible with the bisphenol A bis(allyl carbonate) monomer. HDDMA contributes to high temperature stiffness, polymer clarity and speed of polymerization.

15

TRPGDA, available from Sartomer and Radcure, is a diacrylate monomer that, preferably, is included in the composition because it provides good strength and hardness without adding brittleness to the finished lens.
20 This material is also stiffer than TTEGDA.

TMPTA, available from Sartomer and Radcure, is a triacrylate monomer that, preferably, is included in the composition because it provides more crosslinking in the
25 finished lens than the difunctional monomers. TMPTA has a shorter backbone than TTEGDA and increases the high temperature stiffness and hardness of the finished lens. Moreover, this material contributes to the prevention of optical distortions in the finished lens. TMPTA also
30 contributes to high shrinkage during polymerization. The inclusion of too much of this material in the most preferred composition may make the finished lens too brittle.

35 Certain of the monomers that are preferably utilized in the composition of the present invention, such as

-33-

TTEGDA, TRPGDA and TMPTA, include impurities and have a yellow color in certain of their commercially available forms. The yellow color of these monomers is preferably reduced or removed by passing them through a column of alumina (basic) which includes aluminum oxide powder - basic. After passage through the alumina column, the monomers absorb almost no ultraviolet light. Also after passage through the alumina column differences between monomers obtained from different sources are substantially eliminated. It is preferred, however, that the monomers be obtained from a source which provides the monomers with the least amount of impurities contained therein. The composition preferably is filtered prior to polymerization thereof to remove suspended particles.

The composition of the present invention, preferably, may be prepared according to the following protocol. Appropriate amounts of HDDMA, TTEGDA, TMPTA and TRPGDA are mixed and stirred thoroughly, preferably with a glass rod. The acrylate/methacrylate mixture may then be passed through a purification column.

A suitable purification column may be disposed within a glass column having a fitted glass disk above a teflon stopcock and having a top reservoir with a capacity of approximately 500 ml and a body with a diameter of 22 mm and a length of about 47 cm. The column may be prepared by placing on the fitted glass disk approximately 35 g. of activated alumina (basic), available from ALFA Products, Johnson Matthey, Danvers, MA in a 60 mesh form or from Aldrich in a 150 mesh form. Approximately 10 g. of an inhibitor remover (hydroquinone/methylester remover) available as HR-4 from Scientific Polymer Products, Inc., Ontario, NY then may be placed on top of the alumina and, finally,

-34-

approximately 35 g. of activated alumina (basic) may be placed on top of the inhibitor remover.

5 Approximately 600 g. of the acrylate/methacrylate mixture may then be added above the column packing. An overpressure of 2-3 psi may then be applied to the top of the column resulting in a flow rate of approximately 30 to 38 grams per hour. Parafilm may be used to cover the junction of the column tip and the receiving bottle to
10 prevent the infiltration of dust and water vapor. The acrylate/methacrylate mixture, preferably, may be received in a container that is opaque to ultraviolet radiation.

15 An appropriate amount of bisphenol A bis(allyl carbonate) may then be added to the acrylate/methacrylate mixture to prepare the final monomer mixture.

20 An appropriate amount of a photoinitiator may then be added to the final monomer mixture. The final monomer mixture, with or without photoinitiator, may then be stored in a container that is opaque to ultraviolet radiation.

25 An appropriate amount of a dye may also be added to the final monomer mixture, with or without photoinitiator.

30 After edging, the ultraviolet light cured lenses of the present invention demonstrate excellent organic solvent resistance to acetone, methylethyl ketone, and alcohols.

35 Premature release may occur if the temperature rise of the lens forming composition is uncontrolled. Premature release may also occur if the opposed mold

-35-

members 78 are held too rigidly by the annular gasket 80. There is preferably sufficient flexibility in the gaskets 80 to permit the mold members 78 to follow the lens as it shrinks. Insufficient sealing, unsuitable gasket material and/or a small residual amount of uncured material have also been found to contribute to premature release failures.

For best results, both the casting surfaces 86 and non-casting surfaces 88 of the mold members 78 are finished to optical quality. For instance, a wave on the non-casting surface 88 may be reproduced in the finished lens as a result of the distortion of the incident light.

Mold markings cause differential light intensity conditions under the marking, even when the mark is on the non-casting surface 88 of the mold members 78. The fully exposed region of the lens will tend to be harder, and the lens may have stresses because of this. The portion of the lens under the mark will also tend to be weaker at the end of the curing period. This effect has been observed and may cause premature release or induce cracking.

Mold defects at the edges interfere with the sealing conditions and frequently induce premature release.

According to the present invention, plastic lenses may be produced by irradiating the lens forming material with ultraviolet light that is prevented from passing through the faces of the opposed mold members 78 and instead passes through the transparent or translucent wall of annular gasket 80 of the lens cell 52. By irradiating in this manner, the thicker edge portion of a negative lens receives a higher level of light intensity than the thinner center portion since the light intensity

drops as it passes through the deeper layers of the lens material and glass molds. This method has a desirable advantage of allowing the application of clamping pressure to the front and back molds, which is useful in controlling premature release. This technique will be referred to as through-the-gasket irradiation. Referring to Fig. 7, apparatus 100 is shown for carrying out through-the-gasket irradiation. Apparatus 100 includes lamp chamber 102 having a plurality of ultraviolet light generating lamps 104 disposed therein. A lens cell 52 in accordance with Fig. 6 is suspended in lamp chamber 102. A cover 106 of opaque material is placed over the non-casting surface 88 of each mold member 78 of the lens cell 52. In this manner, ultraviolet light emanating from the plurality of lamps 104 that is incident upon the lens cell 52 acts upon the lens forming material disposed in the lens molding cavity 82 by passing through the outer wall 108 of the annular gasket 80. A spring-loaded clamp 110, preferably, may be used to apply compression pressure upon the opposed mold members 78 of the lens cell 52. The spring-loaded clamp, preferably, may be adjusted to exert variable pressure upon the opposed mold members 78. Moreover, opaque disks 106 may be disposed between the respective jaws of the clamp 110 and the mold members 78 to prevent scratching of the molds and to prevent light leakage through the mold.

An alternate technique for through-the-gasket irradiation is shown in Fig. 8. Referring to Fig. 8, apparatus 200 is shown for carrying out through-the-gasket irradiation. Apparatus 200 includes opposed lamp arrays 202. A lens cell 52 in accordance with Fig. 6 is placed on a turntable 204 disposed between opposed lamp arrays 202. An annular opaque stage 206 is disposed under the front mold member 92 and rests directly on turntable 204. A cap 208 of opaque material

is disposed on the back mold member 90. A weight 210 may be disposed upon the back mold member 90 to exert sufficient clamping pressure to prevent premature release.

5

According to the through-the-gasket irradiation technique, the annular gaskets 80, preferably, are silicone gaskets. Through continued use, however, silicone gaskets tend to become too opaque to allow sufficient ultraviolet light to pass through the gasket to complete the polymerization of the lens forming material. In addition, gaskets having a frosty appearance were observed to yield good quality lenses while gaskets that were clear were observed to yield lenses with optical distortions.

The through-the-gasket irradiation techniques make it relatively easy to exert clamping pressure on the mold members 78. Pressure (up to 30 psi) may be applied to the mold members 78, preferably at or about the onset of gelation of the lens forming material, i.e. after the lens forming material is no longer liquid but before it becomes incompressible. At the beginning of the irradiation when the lens forming material is liquid, however, low clamping pressure (such as 2 lb.) may be applied to the mold members 78, which pressure is not so great that the lens forming material leaks between the gasket 80 and the edges of the mold members 78. These techniques also tend to make it easier to direct evenly distributed ultraviolet light to the lens forming material. The gasket 80 serves as a diffuser and prevents sharp intensity gradients that occur when light is passing through the mold and there is an irregularity in the mold. Since the edge of a lens receives a higher intensity of ultraviolet light than the center of the lens, the through-the-gasket technique, therefore, is

-38-

quite beneficial for the production of negative lenses. Finally, since ultraviolet radiation does not pass through the mold members 78 according to this technique, metal molds which are more flexible (and which tend to exhibit enhanced heat transfer properties) than glass molds can be utilized.

As discussed above, the likelihood of premature release may be affected by a number of often interrelated factors. Factors such as improper mold cleaning, mold thickness, or gasket/mold design may contribute to premature release. Other factors that may contribute to premature release may include light intensity, the chemical formulations, and the amount and identity of the photoinitiator ("PI"). As discussed above, an additional factor related to premature release is the exothermic heat generated by the reaction.

It is believed that as the reaction proceeds, the heat generated tends to reduce the adhesion between the shrinking lens and the mold face. This reduction in adhesion tends to cause the lens to pull away from the mold. In high curvature (i.e. high power) lenses this problem tends to be even more pronounced because of two factors: (1) these lenses have more thickness and thus more material that is generating heat (which thus speeds up the reaction and generates more heat), and (2) these lenses have a greater thickness differential between the thick and thin portions of the lens, which tends to cause stress on the molds due to differential shrinkage. It is also possible that the temperatures generated relatively deep inside a thick lens may cause some vaporization of the monomer. The vaporized monomer may then migrate to the lens/mold interface, breaking the vacuum between the two.

-39-

Because of the problem of premature release, preferably high power lenses are cured to maintain adhesion to the molds. Preferably the molds flex and accommodate stress.

5

Preferably premature release is controlled by controlling the exothermic reaction heat. This heat is preferably controlled by directing cooling fluid such as air at the mold faces. Thus in a preferred embodiment the invention includes the following steps: (1) placing
10 a polymerizable lens forming material in a mold cavity defined in part between a first mold member and a second mold member, (2) directing ultraviolet rays towards at least one of the first or second mold members, and (3)
15 cooling the first mold member and the second mold member with a fluid. In a preferred embodiment the ultraviolet rays are directed towards the mold member(s) while the first and second mold members are cooled. The above steps may be carried out with an apparatus for making a
20 plastic lens that includes: (1) a first mold member, (2) a second mold member spaced apart from the first mold member, the first and second mold members defining a mold cavity, (3) an ultraviolet light generator for generating and directing ultraviolet light toward at least one of
25 the first and second mold members during use, (4) an ultraviolet light filter disposed between the ultraviolet light generator and the first mold member, and between the ultraviolet light generator and the second mold member, and (5) a distributor for directing cooling fluid
30 to the mold members during use.

Preferably both the first and second mold members are "directly" cooled by the fluid. That is, preferably the face of the first mold member and the face of the
35 second mold member is cooled by directing fluid towards the face of both of the mold members. The "face" of the

mold members is the outer mold surface that is not contacting either the gasket or the lens forming materials (see Fig. 6). The fluid may be directed at various angles towards the face of the mold members.

5

Generally less preferred results are achieved if only one (instead of both) of the mold members is directly cooled. It is believed that directly cooling only one of the mold members tends to result in less preferred lenses because doing so unevenly cools the lens material during curing. Thus preferably the first and second mold members are both substantially evenly exposed to the cooling fluid temperatures and flowrates.

15

Preferably fluid is directed from the edges of the mold member faces to the center of the mold member faces. In this manner the fluid that contacts the edges of the mold members is approximately the same temperature at all the edges of the mold members, and approximately the same at all radii from the center of the mold members (with some variances due to variances in the cavity thickness at certain radii). Thus substantially the same thicknesses of the lens material are subjected to fluid that is substantially the same temperature, resulting in a more even cooling of the lens material. Generally less favorable results are achieved if fluid is simply directed across the mold members since the fluid temperature and flow rate at the first edge contacted by the fluid may be somewhat different than the fluid temperature and flow rate at the second mold member edge. Specifically, if cooling fluid is passed over the lens forming material in one direction only, the side opposite the source of fluid tends to remain hotter because the fluid passing over it has picked up the heat from the first side.

35

-41-

Preferably the fluid is air at a temperature of less than 50°C. The fluid may be below 0°C, however in a preferred embodiment the fluid was at a temperature of between 0°C and less than 20°C, preferably about 0-15°C, more preferably about 0-10°C, more preferably still about 3-8°C. In one preferred embodiment the fluid temperature was about 5°C. As shown in Figure 9, a lens forming apparatus 300 for making a plastic lens may include a cooler 312 for supplying cool fluid to the apparatus 300 via conduit 314. The fluid may be supplied to the apparatus 300 and then discharged via conduit 320. The fluid discharged via conduit 320 may be vented via conduit 318 or it may alternately be recirculated via conduit 316 to the cooler 312. The cooler 312 preferably includes a Neslab CFT-50 water/antifreeze chiller (Newington, N.H., U.S.A.). A Neslab-built blower box designed for a minimum temperature of 3°C and 8 cubic feet (about 0.224 cubic meters) per minute of air per air distributor 94 was used with the chiller. The blower box included a heat exchanger coil through which chilled water was circulated, a blower, and a plenum-type arrangement for supplying air to the conduit 314.

If lenses are produced without any mold cooling, the temperature of the mold-lens assembly may rise to above 50°C. Low diopter lenses may be prepared in this fashion, but higher plus or minus diopter lenses may fail. Certain lenses may be made by controlling (e.g., cooling) the temperature of the lens material during cure with circulating uncooled fluid (i.e., fluid at ambient temperatures). The ambient fluid in these systems is directed towards the mold members in the same manner as described above. Circulating ambient temperature fluid permits manufacture of a wider range of prescriptions than manufacture of the lenses without any mold cooling at all. For instance, if the temperature of the

-42-

circulating air is held at slightly less than room temperature (about 19°C), prescriptions from +2 to -3 diopter may be successfully cast. Higher diopeters, either + or -, often tend to fail without circulating
5 cooled fluid.

Most polymerization factors are interrelated. The ideal temperature of polymerization is related to the diopter and thickness of the lens being cast. Thermal
10 mass is a factor. Lower temperatures (below about 10°C) are preferred to cast higher + or - diopter lenses. These lower temperatures tend to permit an increase in photoinitiator concentration, which in turn may speed up the reaction and lower curing time.

15

Preventing premature release is also somewhat dependent upon the flowrates of cooling fluid, as well as its temperature. For instance, if the temperature of the cooling fluid is decreased it may also be possible to
20 decrease the flowrate of cooling fluid. Similarly, the disadvantages of a higher temperature cooling fluid may be somewhat offset by higher flowrates of cooling fluid.

In one embodiment the air flow rates for a dual
25 distributor system (i.e., an air distributor above and below the lens composition) are about 1-30 standard cubic feet (about 0.028 - 0.850 standard cubic meters) per minute per distributor, more preferably about 4-20 cubic feet (about 0.113-0.566 standard cubic meters) per minute
30 per distributor, and more preferably still about 9-15 (about 0.255-0.423 standard cubic meters) cubic feet per minute per distributor. "Standard conditions," as used herein, means 60°F (about 15.556°C) and one atmosphere pressure (about 101.325 kilopascals).

35

-43-

In a preferred embodiment the fluid distributor 94 may include 30 substantially evenly spaced orifices 98 disposed to allow fluid to be directed from the distributor 94 to the mold members. In a preferred
5 embodiment the diameter of fifteen orifices 98 on the one-half of the cylindrical opening 96 closest the plenum portion 95 is about 1/4 inch (about 6.35 mm), and the cumulative volume flowrate of air through such orifices is estimated to be about 6.10 standard cubic
10 feet (about 0.173 standard cubic meters) per minute. In the same embodiment the diameter of fifteen orifices 98 on one-half of the cylindrical opening 96 opposite the plenum portion 95 is about 5/16 inch (about 7.94 mm), and the cumulative volume flowrate of air through such
15 orifices is estimated to be about 8.30 standard cubic feet (about 0.235 standard cubic meters) per minute. Thus the total flowrate for one distributor is estimated to be about 14.40 standard cubic feet (about 0.408 standard cubic meters) per minute, and the total flowrate
20 for two distributors is estimated to be about 28.80 standard cubic feet (about 0.816 standard cubic meters) per minute.

In the same embodiment the edge of the orifices 98
25 in the cylindrical opening 96 are tapered out. In such case the cumulative flowrates for the 1/4 inch (6.35 mm) orifices 98 is estimated to be about 5.89 standard cubic feet (about 0.167 standard cubic meters) per minute, and the flowrate for the 5/16 inch (7.94 mm) orifices 98 is
30 estimated to be about 7.02 standard cubic feet (about 0.199 standard cubic meters) per minute. Thus the total flowrate for one distributor is estimated to be about 12.91 standard cubic feet (about 0.366 standard cubic meters) per minute, and the total flowrate for two
35 distributors is estimated to be about 25.82 standard

-44-

cubic feet (about 0.731 standard cubic meters) per minute.

In an alternate preferred embodiment the diameter of
5 fifteen orifices 98 on the one-half of the cylindrical
opening 96 closest to the plenum portion 95 are about
3/16 inch (about 4.76 mm), and the cumulative volume
flowrate of air through such orifices is estimated to be
about 3.47 standard cubic feet (about 0.98 standard cubic
10 meters) per minute. In the same embodiment the diameter
of fifteen orifices 98 on the one-half of the cylindrical
opening 96 opposite the plenum portion 95 are about 1/4
inch (about 6.35 mm), and the cumulative volume flowrate
of air through such orifices is estimated to be about
15 6.17 standard cubic feet (about 0.175 standard cubic
meters) per minute. Thus the total flowrate for one
distributor is estimated to be about 9.64 standard cubic
feet (about 0.273 standard cubic meters) per minute, and
the total flowrate for two distributors is estimated to
20 be about 19.28 standard cubic feet (about 0.546 standard
cubic meters) per minute.

Actual flowrates through individual orifices 98
tended to vary. The flowrates through the orifices 98
25 that were closest to or most opposite the plenum portion
95 of air distribution device 94 tended to have a
flowrate that is greater than orifices in between these
orifices. These higher flowrates varied up to
approximately 1.2-2.5 times the flowrate of orifices that
30 were in between the closest to and most opposite
orifices.

The above estimated flowrates for orifices 98 in a
preferred embodiment were calculated using a bench model
35 of air distributor 94 connected to air flowrate measuring
devices. The air flowrates for the orifices 98 in the

-45-

bench model were measured. The total air flowrate through the bench model distributor 94 was measured. The total air flowrate for a preferred embodiment distributor 94 was measured. The above flowrates were measured by measuring the average velocity across a cross-sectional area, and then multiplying such velocity by the cross-sectional area. The estimated flowrates for the preferred embodiment orifices 98 were obtained by the following equation:

10

$$P_o = B_o \times (P_A/B_A), \text{ where}$$

P_o = estimated preferred embodiment orifices 98 flowrate,
 P_A = measured preferred embodiment distributor 94 flowrate,
15 B_o = measured bench orifices 98 flowrate, and
 B_A = measured bench distributor 94 flowrate.

The thickness of the glass molds used to cast polymerized lenses may affect the lenses produced. A thinner mold tends to allow more efficient heat transfer between the polymerizing material and the cooling air, thus reducing the rate of premature release. In addition, a thinner mold tends to exhibit a greater propensity to flex. A thinner mold tends to flex during the relatively rapid differential shrinkage between the thick and thin portions of a polymerized lens, again reducing the incidence of premature release. In one embodiment the first or second mold members have a thickness less than about 5.0 mm, preferably about 1.0-5.0 mm, more preferably about 2.0-4.0 mm, and more still about 2.5-3.5 mm.

Higher diopter ("D") lenses both have more mass (and so release more heat during the curing cycle) and also define a greater difference between their thick and thin

-46-

portions than a lower diopter lens. Accordingly, for 74 mm diameter negative lenses stronger than about -2.00 D, it is preferably to reduce the thickness of the front (concave) mold to less than 4 mm and preferably to
5 between 3.0 to 3.5 mm. Corning Glass #9092 mold material tends to exhibit about 50% greater mean deflection value at 3 mm than at 5 mm.

Because a negative lens is thin in the center and
10 thick at the edge, more shrinkage tends to occur at the edge than at the center. Because a hemispherical section of glass will bend more readily toward its radius than away from it, in the case of a minus lens the front mold tends to accommodate the greater shrinkage at the edge by
15 flexing and steepening. A positive lens is just the opposite. The thick section of a plus lens is its center and the edge is thin. The greater shrinkage of the center tends to cause the back (convex) mold to steepen and the front mold to flex very little. In this
20 situation it is preferable to reduce the thickness of the back molds used to cast high diopter positive lenses so as to help reduce the polymerization strain.

The advantages of using a thinner mold are offset
25 somewhat by two disadvantages. Using a thinner mold of the exact radius of curvature as a thicker mold will shift the final focusing power of the finished lens toward the plus side and therefore its radius must be compensated accordingly. Further, thicker molds tend to
30 give better overall optics and show less distortion than the same lens cast with a thin mold.

Preferred mold thicknesses for lenses with a diameter of about 74 mm vary depending on the diopter of
35 the lenses to be formed. For lenses in about the +2.0 to +4.0 diopter range, the front mold thickness is

-47-

preferably about 2.5-7.0 mm, more preferably about 3.0-5.0 mm, and more preferably still about 3.5-4.0 mm, and the back mold thickness is preferably about 2.0-5.0 mm, more preferably 2.0-4.0 mm, and more preferably still
5 about 2.5-3.0 mm. For lenses in about the zero ("plano") to +2.0 diopter range, the front mold thickness is preferably about 2.5-8.0 mm, more preferably about 3.5-6.0 mm, and more preferably still about 4.0-4.5 mm, and the back mold thickness is preferably about 2.0-8.0 mm,
10 more preferably 3.0-6.0 mm, and more preferably still about 3.5-4.5 mm. For lenses in about the -2.0 to zero diopter range, the front mold thickness is preferably about 2.0-8.0 mm, more preferably about 3.0-6.0 mm, and more preferably still about 3.5-4.5 mm, and the back mold
15 thickness is preferably about 2.5-8.0 mm, more preferably 3.5-6.0 mm, and more preferably still about 4.0-4.5 mm. For lenses in about the -4.0 to -2.0 diopter range, the front mold thickness is preferably about 2.0-6.5 mm, more preferably about 2.6-5.0 mm, and more preferably still
20 about 3.2-4.0 mm, and the back mold thickness is preferably about 2.0-8.0 mm, more preferably 3.0-6.0 mm, and more preferably still about 4.0-4.5 mm. For lenses in about the -6.0 to -4.0 diopter range, the front mold thickness is preferably about 2.0-5.0 mm, more preferably
25 about 2.0-4.0 mm, and more preferably still about 2.5-3.5 mm, and the back mold thickness is preferably about 2.0-8.0 mm, more preferably 3.0-6.0 mm, and more preferably still about 4.0-4.5 mm.

30 "Front" mold means the mold member with an inner surface that ultimately forms the surface of an eyeglass lens that is furthest from the eye of an eyeglass lens wearer. "Back" mold means the mold member with an inner
35 surface that ultimately forms the surface of an eyeglass lens that is closest to the eye of a eyeglass lens wearer.

-48-

To minimize premature release and produce water-white ophthalmic lenses, preferably a lens is initially cured as described above. That is, a lens forming material is preferably initially cured at relatively low
5 temperatures, relatively low ultraviolet light intensity, and relatively low photoinitiator concentrations. "Initial" or "first" cure means the cure that transforms the liquid lens forming material into a solid material. Lenses produced as such generally have a Shore D hardness
10 of about 60-78 (for the preferred compositions) when cured for about 15 minutes as described above. The hardness may be improved to about 80-81 Shore D by postcure heating the lens in a conventional oven for about 10 minutes, as described above. In the initial
15 cure it is difficult to raise the hardness and surface cure of ultraviolet cured lenses above the levels described above. Achieving a higher degree of hardness and cure generally requires a faster, hotter reaction. The faster, hotter initial cure reaction, however, tends
20 to lead to poorer yields and lessened lens optical quality.

In a preferred embodiment of the invention, factors such as the level of cure, rigidity, and hardness of
25 ultraviolet light polymerized lenses may be improved. A method of the invention to improve these factors involves making a lens as described above, demolding the lens, and then subjecting the lens to relatively high intensity ultraviolet light postcure conditions. This method may
30 be carried out using a system partially shown in Figure 9 including: (i) an apparatus 300 for making a plastic lens which includes (1) a first mold member, (2) a second mold member spaced apart from the first mold member, and the first and second mold members defining a mold cavity,
35 (3) a first ultraviolet light generator for generating and directing ultraviolet light towards at least one of

the first and second mold members during use, (4) an ultraviolet light filter disposed between the first ultraviolet light generator and the first mold member, and between the first ultraviolet light generator and the
5 second mold member, and (5) a distributor for directing cooling fluid towards the first and second mold members during use; (ii) a second ultraviolet light generator 304 for generating and directing ultraviolet light towards the lens during use; and (iii) a first heater 306 to heat
10 the lens during use. The system may also include a third ultraviolet light generator 308 for generating and directing ultraviolet light towards the lens during use after the lens has been heated. The system may also include a second heater 310 for heating the lens during
15 use after the third ultraviolet light generator has directed light towards the lens. The system may also include a demolder 302, which may simply include a small hammer and chisel.

20 In a preferred embodiment the second and third ultraviolet light generators are the same generator. In a preferred embodiment the first and second heaters are the same heater. In a preferred embodiment the first and second heater may be incorporated with the second and
25 third UV light generators. The system may also include additional heaters and or UV light generators.

Preferably the second and/or third ultraviolet light generators provide ultraviolet light at an intensity of
30 about 150-300 mW/cm², more preferably about 175-250 mW/cm², at a wavelength range of about 360-370 nm (preferably about 365nm). Preferably the second and/or third ultraviolet light generators provide ultraviolet light at an intensity of about 50-150 mW/cm², more
35 preferably about 75-125 mW/cm² at a wavelength range of about 250-260 nm (preferably about 254 nm). The first or

-50-

initial ultraviolet light generator preferably provides ultraviolet light at a total intensity (from both sides) of less than 10 mW/cm² (preferably about 0.3-2.0 mW/cm²). Thus preferably the second or third ultraviolet light

5 generators provide at least about 2, 5, 10, 20, 40, 100, 500, 1000, and/or 1800 times the intensity of ultraviolet light than is provided by the first ultraviolet light generator. Preferably these generators provide about 40-

10 100, 100-500, 500-1800, 100-1800, and/or 40-1800 times the amount of light provided by the first ultraviolet light generator. Preferably the lens is exposed to the ultraviolet light in the second, third and/or subsequent ultraviolet light generators for less than about 5

15 minutes, more preferably less than 1.0 minute, and more preferably still less than about 30 seconds. Preferably this exposure time is about 0.1-300 seconds, more preferably about 0.1-60 seconds, and more preferably still about 0.1-30 seconds. In another preferred embodiment the exposure time was less than 5 minutes.

20 Generally as the intensity of the light is increased, the exposure time may be decreased, and vice versa.

Preferably the lens is heated in the first or second heaters for less than about 180 minutes, more preferably

25 less than 30 minutes, and more preferably still less than about 10 minutes. Preferably the lens is heated in the second and/or third heaters at a temperature of about 65-180°C, more preferably about 85-140°C, and more preferably still about 100-120°C. Generally as the

30 temperature is decreased, the amount of heating time should be increased, and vice versa. In another preferred embodiment the heating time was less than 5 seconds.

35 The lens is preferably cleaned (e.g., in a 50 volume % methanol/water solution) prior to exposing the lens to

the relatively high intensity light. The relatively high intensity light may include relatively long and/or short wavelengths. The lens may then be heated. The lens may be repeatedly exposed to relatively high intensity
5 ultraviolet light. The lens may be repeatedly heated.

In a preferred embodiment, the high intensity light may be provided with mercury vapor lamps provided in a UVEXS, Inc. Model CCU curing chamber (Sunnyvale, CA,
10 U.S.A.).

It is believed that shorter wavelengths tend to improve the extent of surface cure and that longer wavelengths tend to increase the extent of cure within
15 the middle portions of the lens. Thus it is preferably to use both shorter and longer ultraviolet light wavelengths for the second and third ultraviolet light generators. Exposure to the relatively high intensity UV wavelengths tends to yellow the lens, however
20 subsequently heating the lens tends to reduce and/or eliminate this yellowing. Preferably the lens is heated to about 110-120°C. Heating also allows radicals to terminate and tends to increase the crosslinking of the compounds within the lens. The polymerization strain
25 also tends to be reduced during heating.

Lenses cured according to the above procedure exhibited a Shore D hardness of above 83, with most lens about 83-85. These lenses also were more rigid and
30 tended to warp less when inserted into an eyeglass frame after edging. There was negligible difference in the impact resistance and scratch resistance of the lenses cured in this fashion, compared to lenses cured without exposure to the relatively high intensity UV light. It
35 is anticipated that the postcure methods described above will tend to remedy lesser defects that may occur in the

-52-

first cure using the first UV light generator. For instance, the cure level for relatively low mass lenses during the first cure may be less important since the postcure will tend to ensure that the lenses are
5 adequately cured. In like manner, different lens compositions that do not cure to form ophthalmic quality lenses in the first cure may be now usable since the postcure method may increase the quality of the cured lenses. For instance, the amount of photoinitiator and/or
10 stabilizers in the initial composition may be varied over a broader range and still achieve acceptable water-white lenses.

In an alternate method for making a lens, the
15 desired curvature (i.e., power) of the lens may be varied using the same molds, but with different light distributions. In this manner one mold may be used to prepare different lenses with different curvatures. The method includes the steps of: (1) placing a polymerizable
20 lens forming material in a mold cavity defined in part between a first mold member and a second mold member, and wherein the cavity defines a theoretical curvature that is different from the desired curvature, (2) directing ultraviolet rays towards at least one of the first and
25 second mold members, and wherein the ultraviolet rays are directed towards the first or second mold member such that the material cures to form a lens with the desired curvature, and (3) contacting fluid against the first or
30 second mold member to cool the first or second mold member. The resulting lens curvature may vary depending on the way the ultraviolet light is directed towards the first or second mold members. That is, by varying the relative intensity of the light across the lens material radii, it is possible to vary the curvature of the
35 resulting lens.

Lens curvatures may also vary when the lenses are subjected to postcure heating. Thus the curvature of the lenses may be varied by exposing the lens material to UV light, and then demolding and heating the lens. The heating may then result in the desired curvature, and this curvature may be different from the theoretical curvature expected from the dimensions of the mold cavity, as well as the curvature obtained after the lens has been exposed to the initial UV light.

10

The present invention will now be described in more detail with reference to the following examples. These examples are merely illustrative of the present invention and are not intended to be limiting.

15

EXAMPLE 1 - LENS CURVATURE (POWER) VARIANCES

Lenses were produced under various conditions according to the compositions, methods and apparatus of the present invention.

20

The formulation used to prepare the lenses according to this example included: 17.0% by weight of CR-73, 10.0% by weight of HDDMA, 21.0% by weight of TTEGDA, 32.0% by weight of TRPGDA, 20.0% by weight of TMPTA, 0.0356% by weight of methyl benzoylformate, 0.0095% by weight of Irgacure 184, and 0.16 ppm of Thermoplast Blue 684. The refractive index of this formulation ranged from 1.468 to 1.478. The refractive index of the lenses produced according to this example ranged from 1.507 to 1.511.

25
30

The method used to prepare the lenses according to this example was through the mold irradiation with air-cooling.

35

-54-

The gaskets used to prepare the lenses according to this example were GE SE6035 silicone rubber gaskets.

5 The molds used to prepare the lenses according to this example were made from Schott S-3 glass and had approximately parallel surfaces averaging 4 mm in thickness.

10 The intensity of ultraviolet light from the top measured at the center of the lens cell ranged from 0.35 mW/cm² to 0.37 mW/cm² for all lenses prepared according to this example. The ultraviolet lamps were kept at a temperature between 78 and 98 F.

15 For all lenses prepared according to this example, the upper light filter included 2 Pyrex glass sheets each frosted on one side with one sheet of tracing paper between them and the lower light filter also included 2 Pyrex glass sheets each frosted on one side with one
20 sheet of tracing paper between them. In some cases the lower light filter included an opaque disc. The opaque disk tended to decrease the amount of light reaching the mold members, with the decrease maximized at the center of the mold members. The light tended to decrease in
25 lesser amounts at points more distant from the center.

The following curing conditions were constant for all lenses prepared according to this example:

30 -- ambient temperature -- 22°C
-- cooling air temperature -- 23.5°C
-- exit air flow rate
35 at vent 33 -- 20 ft³/min.
-- distance from disk to
centerline of stage -- 38 mm.

40

The results are shown in Table 1 below. The results of this example for positive lenses demonstrate that as the diameter of the opaque disk at the lower light filter is increased: 1) the bottom light intensity is
5 decreased, 2) the flexing of both the front and back molds is increased, 3) the power of the lenses before and after post-cure is reduced or less positive and, 4) the variance from the predicted power is reduced.

10 The results for negative lenses demonstrate that as the diameter of the opaque disk at the lower light filter is increased: 1) the bottom light intensity is decreased, 2) the flexing of both the front and back
15 molds was essentially identical, 3) the power of the lenses before and after post-cure is increased or more negative, and, 4) the variance from the predicted power is reduced.

TABLE 1

	disc diameter	bottom light intensity in center W/cm ²	flexing		Power upon demolding	Power upon post-cure	Predicted Power	Variance from predicted power
			front mold	back mold				
5	0	.51	-.05	-.09	+1.82	+1.92	+1.80	+.12
10	21	.44	-.06	-.10	+1.76	+1.85	+1.80	+.05
15	39	.33	-.09	-.13	+1.66	+1.75	+1.80	-.05
20	0	.51	+0.10	+0.04	-1.80	-1.91	-1.98	+0.07
25	21	.44	+0.09	+0.04	-1.86	-1.94	-1.99	+0.05
30	39	.33	+0.07	+0.02	-1.90	-1.97	-1.99	+0.02
35	0	.51	+0.18	+0.06	-3.72	-3.94	-4.02	+0.08
40	21	.44	+0.18	+0.07	-3.74	-3.96	-4.02	+0.06
45	39	.33	+0.14	+0.05	-3.83	-4.00	-4.02	+0.02

40 The results shown in Table 1 clearly demonstrate that the lenses produced according to the present invention are in a stressed condition after ultraviolet light curing. The results also demonstrate that the stressed condition of the lenses may be reduced by an

45 appropriate post-curing heating step. The results also demonstrate that the power of a finished lens produced according to the present invention may be altered by manipulating the intensity of ultraviolet light incident on a lens cell during the curing of a lens.

EXAMPLE 2 - LIQUID COOLING

As noted above, according to one embodiment of the present invention, the lens cell 52 may be cooled by disposing it in a liquid cooling bath. According to this process a lens was cured under the following conditions: The lens cell was made up of a 5.75 D front mold, a 7.50 D back mold and a silicone rubber gasket. The lens forming composition was 17% CR-73, 20% TMPTA, 21% TTEGDA, 32% TRPGDA, 10% HDDMA, .0336% MBZF, and .0084 Irgacure 184. The resultant center thickness was 2.4 mm. The lens molding cavity 82 was filled with lens forming material and the lens cell was placed on a supporting stage in a bath of 85% H₂O with 15% propylene glycol at 0°C. A triangular array of ultraviolet lamps was utilized and the incident light intensity was 2.8 mW/cm² from the top and 1.5 mW/cm² from the bottom. The lens cell was irradiated for 10 minutes and the resultant lens had a measured focusing power of -1.80 D. The lens did not release and exhibited excellent stress patterns. The Shore D hardness was 67.

EXAMPLE 3 - THROUGH THE GASKET CURING

As noted above, according to one embodiment of the present invention, the lens forming material can be polymerized by irradiating only through the gasket. The lens forming composition was 26% CR-73, 25% HDDMA, 16% TMPTA, 15% TTEGDA, 16% TRPGDA, 2% styrene, .03% Irgacure 184, and about 0.3 ppm of Thermoplast Blue. According to this technique, a lens cell including a soft silicone rubber gasket configured for creating a -4.25 D lens was suspended in the center of a cylindrical array of Sylvania fluorescent F-15 8T/2052 lamps positioned at a distance from the lens cell to create an average light intensity of approximately 2 mW/cm² on the gasket 80 of

the lens cell 52. The sample was irradiated for 40 minutes with 16 pounds of pressure being applied after 13 minutes of irradiation. The pressure was later increased to a total of 21.5 pounds. The lens did not release,
 5 gave excellent stress patterns and good optics.

EXAMPLE 4 - REDUCED TEMPERATURE CURING

Formulation: 17% Bisphenol A BisAllyl Carbonate
 10 10% 1,6 Hexanediol dimethacrylate
 20% Trimethylolpropane triacrylate
 21% Tetraethyleneglycol diacrylate
 32% Tripropyleneglycol diacrylate
 0.012% 1 Hydroxycyclohexyl phenyl ketone
 15 0.048 Methylbenzoylformate
 <10PPM Hydroquinone &
 Methylenehydroquinone

Hydroquinone and Methylenehydroquinone were
 20 stabilizers present in some of the diacrylate and/or triacrylate compounds obtained from Sartomer. Preferably the amount of stabilizers is minimized since the stabilizers affect the rate and amount of curing. If larger amounts of stabilizers are added, then generally
 25 larger amounts of photoinitiators must also be added.

Light Condition: mW/cm² measured at plane of sample

	Center	Edge
30	-----	-----
	Top: 0.233	0.299
	Bottom: 0.217	0.248

Air Flow: 9.6 standard cubic feet ("CFM") per manifold /
 35 19.2 CFM total on sample

Air Temperature: 4.4 degrees Centigrade

Molds: 80 mm diameter Corning #8092 glass

5		Radius	Thickness
		-----	-----
	Concave:	170.59	2.7
	Convex:	62.17	5.4

10 Gasket: General Electric SE6035 silicone rubber with a 3 mm thick lateral lip dimension and a vertical lip dimension sufficient to provide an initial cavity center thickness of 2.2 mm.

15 Filling: The molds were cleaned and assembled into the gasket. The mold/gasket assembly was then temporarily positioned on a fixture which held the two molds pressed against the gasket lip with about 1 kg. of pressure. The upper edge
 20 of the gasket was peeled back to allow about 27.4 grams of the monomer blend to be charged into the cavity. The upper edge of the gasket was then eased back into place and the excess monomer was vacuumed out with a small
 25 aspirating device. It is preferable to avoid having monomer drip onto the noncasting surface of the mold because a drop tends to cause the ultraviolet light to become locally focused and may cause an optical distortion in the final
 30 product.

Curing: The sample was irradiated for fifteen minutes under the above conditions and removed from the curing chamber. The molds were separated from
 35 the cured lens by applying a sharp impact to the junction of the lens and the convex mold.

The sample was then postcured at 110 °C in a conventional gravity type thermal oven for an additional ten minutes, removed and allowed to cool to room temperature.

5

Results: The resulting lens measured 72 mm in diameter, with a central thickness of 2.0 mm, and an edge thickness of 9.2 mm. The focusing power measured ~5.05 diopter. The lens was water clear ("water-white"), showed negligible haze, exhibited total visible light transmission of about 94%, and gave good overall optics. The Shore D hardness was about 80. The sample withstood the impact of a 1 inch steel ball dropped from fifty inches in accordance with ANSI 280.1-1987, 4.6.4 test procedures.

10

15

EXAMPLE 5 - REDUCED TEMPERATURE CURING

20 Formulation: 17% Bisphenol A BisAllyl Carbonate
 10% 1,6 Hexanediol dimethacrylate
 20% Trimethylolpropane triacrylate
 21% Tetraethyleneglycol diacrylate
 32% Tripropyleneglycol diacrylate
 25 0.012% 1 Hydroxycyclohexyl phenyl ketone
 0.048% Methylbenzoylformate
 <10PPM Hydroquinone &
 Methylenehydroquinone

30 Light Condition: mW/cm² measured at plane of sample

	Center	Edge
	-----	-----
Top:	0.251	0.330
35 Bottom:	0.236	0.265

-61-

Air Flow: 9.6 CFM per manifold / 19.2 CM total on sample

Air temperature: 4.4 degrees Centigrade

5 Molds: 80 mm dia. Corning #8092 glass

	Radius	Thickness
	-----	-----
10	Concave: 113.28	3.2
	Convex: 78.64	5.5

15 Gasket: General Electric SE6035 silicone rubber with a 3 mm thick lateral lip dimension and a vertical lip dimension sufficient to provide a initial cavity center thickness of 1.9 mm.

20 Filling: The molds were cleaned and assembled into the gasket. The mold/gasket assembly was then temporarily positioned on fixture which held the two molds pressed against the gasket lip with about 1 kg. of pressure. The upper edge of the gasket was peeled back to allow about 15.1 grams of the monomer blend to be charged into the cavity. The upper edge of the gasket was then eased back into place and the excess monomer was vacuumed out with a small aspirating device. It is preferable to avoid having monomer drip onto the noncasting surface of the mold because a drop will cause the ultraviolet light to become locally focused too strongly on the monomer in the cavity and may cause an optical distortion in the final product.

35 Curing: The sample was irradiated for fifteen minutes under the above conditions and removed from the

5 curing chamber. The molds were separated from the cured lens by applying a sharp impact to the junction of the lens and the convex mold. the sample was then postcured at 110 degrees C in a conventional gravity type thermal oven for an additional ten minutes, removed and allowed to cool to room temperature.

10 Results: The resulting lens measured 73 mm in diameter, with a central thickness of 1.7 mm, and an edge thickness of 4.3 mm. The focusing power measured ~1.90 diopters. The lens was water clear, showed no haze, exhibited total visible light transmission of 94%, and gave good
15 overall optics. The Shore D hardness was 81. The sample withstood the impact of a 7/8 inch steel ball dropped from fifty inches in accordance with ANSI 280.1-1987, 4.6.4 test procedure.

20

EXAMPLE 6 - REDUCED TEMPERATURE CURING

Formulation:	17%	Bisphenol A BisAllyl Carbonate
	10%	1,6 Hexanediol dimethacrylate
25	20%	Trimethylolpropane triacrylate
	21%	Tetraethyleneglycol diacrylate
	32%	Tripropyleneglycol diacrylate
	0.012%	1 Hydroxycyclohexyl phenyl ketone
	0.048%	Methylbenzoylformate
30	<10PPM	Hydroquinone & methylethylhydroquinone

Light Condition: mW/cm² measured at plans of sample

	Center -----	Edge -----
Top:	0.233	0.299
Bottom:	0.217	0.248

5

Air Flow: 9.6 CFM per manifold / 19.2 CFM total on sample

Air Temperature: 12.3 degrees Centigrade

10 Molds: 80 mm dia. Corning #8092 glass

	Radius -----	Thickness -----
Concave:	170.59 mm	2.7 mm
Convex:	62.17 mm	5.4 mm

15

Gasket: General Electric SE6035 silicone rubber with a 3 mm thick lateral lip dimension and a vertical lip dimension sufficient to provide an initial cavity center thickness of 2.2 mm.

20

Filling: The molds were cleaned and assembled into the gasket. The mold/gasket assembly was then temporarily positioned on fixture which held the two molds pressed against the gasket lip with about 1 kg. of pressure. The upper edge of the gasket was peeled back to allow about 27.4 grams of the monomer blend to be charged into the cavity. The upper edge of the gasket was then eased back into place and the excess monomer was vacuumed out with a small aspirating device. It is preferable to avoid having monomer drip onto the noncasting surface of the mold because a drop will cause the ultraviolet light to become locally focused too strongly on the monomer in the cavity and may

25

30

35

cause an optical distortion in the final product.

5 Curing: The sample was irradiated for fifteen minutes under the above conditions and removed from the curing chamber.

10 Results: The sample was found to have released from the front mold prematurely. The sample also showed signs of heat bubbling around the edges.

EXAMPLE 7 - REDUCED TEMPERATURE CURING

15 Formulation: 17% Bisphenol A BisAllyl Carbonate
 10% 1,6 Hexanediol dimethacrylate
 20% Trimethylolpropane triacrylate
 21% Tetraethyleneglycol diacrylate
 32% Tripropyleneglycol diacrylate
 0.012% 1 Hydroxycyclohexyl phenyl ketone
 20 0.048% Methylbenzoylformate
 <10PPM Hydroquinone &
 Methylenehydroquinone

25 Light Condition: mW/cm² measured at plane of sample

	Center	Edge
	-----	-----
Top:	0.251	0.330
Bottom:	0.236	0.265

30 Air Flow: 9.6 CFM per manifold / 19.2 CFM total on sample

Air Temperature: 12.3 degrees Centigrade

35 Molds: 80 mm dia. Corning #8092 glass

-65-

	Radius	Thickness
	-----	-----
Concave:	123.28 mm	3.2 mm
Convex:	78.64 mm	5.5 mm

5

Gasket: General Electric SE6035 silicone rubber with a 3 mm thick lateral lip dimension and a vertical lip dimension sufficient to provide an initial cavity center thickness of 1.9 mm.

10

Filling: The molds were cleaned and assembled into the gasket. The mold/gasket assembly was then temporarily positioned on fixture which held the two molds pressed against the gasket lip with about 1 kg. of pressure. The upper edge of the gasket was peeled back to allow about 15.1 grams of the monomer blend to be charged into the cavity. The upper edge of the gasket was then eased back into place and the excess monomer was vacuumed out with a small aspirating device. It is preferable to avoid having monomer drip onto the noncasting surface of the mold because a drop will cause the ultraviolet light to become locally focused too strongly on the monomer in the cavity and may cause an optical distortion in the final product.

15

20

25

30

35

Curing: The sample was irradiated for fifteen minutes under the above conditions and removed from the curing chamber. The molds were separated from the cured lens by applying a sharp impact to the junction of the lens and the convex mold. The sample was then postcured at 110 degrees C in a conventional gravity type thermal oven for

an additional ten minutes, removed and allowed to cool to room temperature.

5 Results: The resulting lens measured 73 mm in diameter,
 with a central thickness of 1.7 mm, and an edge
 thickness of 4.3 mm. The focusing power
 measured ~1.90 diopters. The lens was water
 clear, showed no haze, exhibited total visible
 light transmission of 94%, and gave good
 10 overall optics. The Shore D hardness was 81.
 The sample withstood the impact of a 7/8 inch
 steel ball dropped from fifty inches in
 accordance with ANSI 280.1-1987, 4.6.4 test
 procedure.

15

EXAMPLE 8 - REDUCED TEMPERATURE CURING

Formulation: 17% Bisphenol A BisAllyl Carbonate
 10% 1,6 Hexanediol dimethacrylate
 20 20% Trimethylolpropane triacrylate
 21% Tetraethyleneglycol diacrylate
 32% Tripropyleneglycol diacrylate
 0.009% 1 Hydroxycyclohexyl phenyl ketone
 0.036% Methylbenzoylformate
 25 <10PPM Hydroquinone &
 Methylethyhydroquinone

Light Condition: mW/cm² measured at plane of sample

30 Center Edge
 ----- -----
 Top: 0.233 0.299
 Bottom: 0.217 0.248

35 Air Flow: 9.6 CFM per manifold / 19.2 CFM total on sample

-67-

Air Temperature: 12.2 degrees Centigrade

Molds: 80 mm dia. Corning #8092 glass

5	Radius	Thickness
	-----	-----
	Concave: 170.59 mm	2.7 mm
	Convex: 62.17 mm	5.4 mm

10 Gasket: General Electric SE6035 silicone rubber with a 3 mm thick lateral lip dimension and a vertical lip dimension sufficient to provide an initial cavity center thickness of 2.2 mm.

15 Filling: The molds were cleaned and assembled into the gasket. The mold/gasket assembly was then temporarily positioned on fixture which held the two molds pressed against the gasket lip with about 1 kg. of pressure. The upper edge
 20 of the gasket was peeled back to allow about 27.4 grams of the monomer blend to be charged into the cavity. The upper edge of the gasket was then eased back into place and the excess monomer was vacuumed out with a small
 25 aspirating device. It is preferable to avoid having monomer drip onto the noncasting surface of the mold because a drop will cause the ultraviolet light to become locally focused too strongly on the monomer in the cavity and may
 30 cause an optical distortion in the final product.

Curing: The sample was irradiated for fifteen minutes under the above conditions and removed from the
 35 curing chamber. The molds were separated from the cured lens by applying a sharp impact to

5 the junction of the lens and the convex mold.
 The sample was then postcured at 110 degrees C
 in a conventional gravity type thermal oven for
 an additional ten minutes, removed and allowed
 to cool to room temperature.

10 Results: The resulting lens measured 72 mm in diameter,
 with a central thickness of 2.0 mm, and an edge
 thickness of 9.2 mm. The focusing power
 measured ~5.05 diopters. The lens was water
 clear, showed no haze, exhibited total visible
 light transmission of 94%, and gave good
 overall optics. The Shore D hardness was 80.5.
 15 The sample withstood the impact of a 1 inch
 steel ball dropped from fifty inches in
 accordance with ANSI 280.1-1987, 4.6.4 test
 procedure.

EXAMPLE 9 - REDUCED TEMPERATURE CURING

20 Formulation: 17% Bisphenol A BisAllyl Carbonate
 10% 1,6 Hexanediol dimethacrylate
 20% Trimethylolpropane triacrylate
 21% Tetraethyleneglycol diacrylate
 25 32% Tripropyleneglycol diacrylate
 0.012% 1 Hydroxycyclohexyl phenyl ketone
 0.048% Methylbenzoylformate
 <10PPM Hydroquinone &
 Methylenehydroquinone

30 Light Condition: mW/cm² measured at plane of sample

	Center	Edge
	-----	-----
35 Top:	0.251	0.330
Bottom:	0.236	0.265

Air Flow: 9.6 CFM per manifold / 19.2 CFM total on sample

Air Temperature: 22.2 degrees Centigrade

5 Molds: 80 mm dia. Corning #8092 glass

	Radius	Thickness
	-----	-----
10	Concave: 113.28 mm	3.2 mm
	Convex: 78.64 mm	5.5 mm

15 Gasket: General Electric SE6035 silicone rubber with a 3 mm thick lateral lip dimension and a vertical lip dimension sufficient to provide an initial cavity center thickness of 1.9 mm.

20 Filling: The molds were cleaned and assembled into the gasket. The mold/gasket assembly was then temporarily positioned on fixture which held the two molds pressed against the gasket lip with about 1 kg. of pressure. The upper edge of the gasket was peeled back to allow about 15.1 grams of the monomer blend to be charged into the cavity. The upper edge of the gasket

25 was then eased back into place and the excess monomer was vacuumed out with a small aspirating device. It is preferable to avoid having monomer drip onto the noncasting surface of the mold because a drop will cause the

30 ultraviolet light to become locally focused too strongly on the monomer in the cavity and may cause an optical distortion in the final product.

35 Curing: The sample was irradiated for fifteen minutes under the above conditions and removed from the

5 curing chamber. The molds were separated from the cured lens by applying a sharp impact to the junction of the lens and the convex mold. The sample was then postcured at 110 degrees C in a conventional gravity type thermal oven for an additional ten minutes, removed and allowed to cool to room temperature.

10 Results: The resulting lens measured 73 mm in diameter, with a central thickness of 1.7 mm, and an edge thickness of 4.3 mm. The focusing power measured ~1.87 diopters. The lens was water clear, showed no haze, exhibited total visible light transmission of 94%, and gave good
 15 overall optics. The Shore D hardness was 83. The sample withstood the impact of a 1 inch steel ball dropped from fifty inches in accordance with ANSI 280.1-1987, 4.6.4 test procedure.

20

EXAMPLE 10 - REDUCED TEMPERATURE CURING

Formulation: 17% Bisphenol A BisAllyl Carbonate
 10% 1,6 Hexanediol dimethacrylate
 25 20% Trimethylolpropane triacrylate
 21% Tetraethyleneglycol diacrylate
 32% Tripropyleneglycol diacrylate
 0.009% 1 Hydroxycyclohexyl phenyl ketone
 0.036% Methylbenzoylformate
 30 <10PPM Hydroquinone & Methylenehydroquinone

Light Condition: Mw/cm² measured at plane of sample

35

Center	Edge
-----	-----

-71-

Top:	0.233	0.299
Bottom:	0.217	0.248

Air Flow: 9.6 CFM per manifold / 19.2 CFM total on sample

5

Air Temperature: 22.2 degrees Centigrade

Molds: 80 mm dia. Corning #8092 glass

10		Radius	Thickness
		-----	-----
	Concave:	170.59 mm	2.7 mm
	Convex:	62.17 mm	5.4 mm

15 Gasket: General Electric SE6035 silicone rubber with a 3 mm thick lateral lip dimension and a vertical lip dimension sufficient to provide an initial cavity center thickness of 2.2 mm.

20 Filling: The molds were cleaned and assembled into the gasket. The mold/gasket assembly was then temporarily positioned on fixture which held the two molds pressed against the gasket lip with about 1 kg. of pressure. The upper edge
25 of the gasket was peeled back to allow about 27.4 grams of the monomer blend to be charged into the cavity. The upper edge of the gasket was then eased back into place and the excess monomer was vacuumed out with a small
30 aspirating device. It is preferable to avoid having monomer drip onto the noncasting surface of the mold because a drop will cause the ultraviolet light to become locally focused too strongly on the monomer in the cavity and may
35 cause an optical distortion in the final product.

- Curing: The sample was irradiated for fifteen minutes under the above conditions and removed from the curing chamber.
- 5 Results: The sample was found to have released from the molds prematurely. It also showed heat bubbles at the edge.

EXAMPLE 11 - HIGH INTENSITY UV POSTCURE - 1 COMPOSITION

10

A number of lenses were prepared with the same physical molds and gasket, with the same lens forming composition, and under identical initial UV light curing conditions. These lenses were then subjected to various combinations of second and/or third UV intensity/time and temperature/time conditions. The results for Shore D hardness and impact resistance of each lens are shown in Table 2. The second or third UV source was a UVEXS CCU curing chamber configured with a medium pressure vapor lamp, a collimated dichroic reflector which reduced the IR radiation of the lamp by 50%, and two selectable output levels. The low setting provides approximately 175 mW/cm² at about 365 nm and 70 mW/cm² at about 254 nm. The high setting produces about 250 mW/cm² at about 365 nm and 100 mW/cm² at about 254 nm. The initial curing conditions are identified below.

Formulation:	17%	Biaphenol A BisAllyl Carbonate
	10%	1,6 Hexanediol dimethacrylate
30	20%	Trimethylolpropane triacrylate
	21%	Tetraethyleneglycol diacrylate
	32%	Tripropyleneglycol diacrylate
	0.012%	1 Hydroxycyclohexyl phenyl ketone
	0.048	Methylbenzoylformate
35	<10PPM	Hydroquinone & Methylethylhydroquinone

-73-

Initial Cure

Light Condition: Mw/cm² measured at plane of sample

	Center	Edge
5	-----	-----
	Top: 0.251	0.330
	Bottom: 0.236	0.265

Air Flow: 9.6 CFM per manifold / 19.2 CFM total on sample

10

Air Temperature: 4.8 degrees Centigrade

Molds: 80 mm dia. Corning #8092 glass

	Radius	Thickness
15	-----	-----
	Concave: 113.22	3.2
	Convex: 78.52	5.2

20	Lens Power:	-1.90 D
	Lens Thickness:	2.2 mm
	Lens Diameter:	73 mm

25 Gasket: General Electric SE6035 silicone rubber with a 3 mm thick lateral lip dimension and a vertical lip dimension sufficient to provide an initial cavity center thickness of 2.4 mm.

30 Curing: The sample was irradiated for fifteen minutes under the above conditions and removed from the curing chamber. The molds were separated from the cured lens by applying a sharp impact to the junction of the lens and the convex mold. The sample was then postcured as described.

35 Unless otherwise indicated, the stated "hard" or high intensity UV postcure time/intensity

5 doses were applied twice -- i.e., first to the
convex surface and then to the concave surface
for each exposure. For example, if the dose is
described as "1.4 sec/low", it means that the
front surface of the lens was exposed for 1.4
seconds to the low intensity rays and then the
lens was turned over and the back was exposed
for the same length of time to the same
intensity level of light. The term "CX" means
10 convex, the term "CC" means concave, the term
"HD" means Shore D hardness, "pass" means the
lens passed the 1" steel ball impact resistance
test described in the previous examples (see
e.g., example 9), "2nd UV" means the first UV
15 postcure light (the initial cure was the "1st
UV"), and "3rd UV" means the second UV postcure
light. Time units are in minutes, unless "sec"
for seconds is specified. Temperature is
defined in degrees Centigrade.

20

TABLE 2
HIGH INTENSITY UV/THERMAL POSTCURE EXAMPLES

	2nd UV Lamp Time/ Intensity	1st Thermal Postcure Time/Temp	3rd UV Lamp Time/ Intensity	2nd Thermal Postcure Time/Temp	Shore D Hardness	Impact 1" Ball
5	0	0	0	0	65	--
10	0	10:00/115° C	0	0	80	Pass
	1.4 sec/ low	10:00/115° C	0	0	82	7/8"
15	0	5:00/115°C	1.4 sec/low	5:00/ 115C	83	Pass
	1.4 sec/ low	5:00/115°C	1.4 sec/low	5:00/ 115C	85	Pass
	1.4 sec/ low	5:00/ 65°C	1.4 sec/low	5:00/ 65C	80	Pass
20	1.4 sec/ low	5:00/ 65°C	1.4 sec/low	15:00/65C	81	Pass
	1.4 sec/ low	5:00/ 65°C	1.4 sec/low	25:00/65 C	81	Pass
25	1.4 sec/ low	5:00/ 80°C	1.4 sec/low	5:00/80C	82	Pass
	1.4 sec/ low	5:00/140°C	1.4 sec/low	5:00/140C	85	Pass
	1.4 sec/ low	5:00/180°C	1.4 sec/low	5:00/180C	85	Pass
30	12.0 sec/ high	0	0	0	80	Pass
	12.0 sec/ high	1:00/180°C	0	0	83	Pass

5

#	2nd UV Lamp Time/ Intensity	1st Thermal Postcure Time/Temp	3rd UV Lamp Time/ Intensity	2nd Thermal Postcure Time/Temp	Shore D Hardness	Impact 1" Ball
14	12.0 sec/ high	10:00/115° C	0	0	85	Pass
15	12.0 sec/ high	30:00/ 65°C	0	0	83	Pass
16	12.0 sec/ high	10:00/115° C	1.0 sec/low	0	85	Pass
17	1.0 sec/ low (Exposed CX side 1X only, CC side 0 times)	5:00/115°C	1.0 sec/low (Exposed CX side 1X only, CC side 0 times)	5:00/115C	83	Pass

10

EXAMPLE 12 - HIGH INTENSITY UV POSTCURE -
VARIOUS COMPOSITIONS

15 A number of lenses made from different compositions were prepared with the same physical molds and gasket, and under identical initial curing conditions. The lenses were then subjected to fixed postcure procedures with fixed UV intensity/time and temperature/time conditions. It should be noted that each of the acrylic components were passed through an alumina column to remove impurities and inhibitors before use. The results for Shore D hardness after the postcure, and the impact resistance of each product are shown in Table 3. The postcure UV source used was a UVEXS CCU curing chamber
20 configured with a medium pressure vapor lamp, a collimated dichroic reflector which reduced the IR radiation of the lamp by 50%, and two selectable output
25

levels. The low setting provides approximately 175 mW/cm² at about 365 nm and 70 mW/cm² at about 254 nm. The high setting produces about 250 mW/cm² at about 365 nm and 100 mW/cm² at about 254 nm. The initial curing conditions are identified below.

Initial Cure

Light Condition: Mw/cm² measured at plane of sample

10	Center	Edge
	-----	-----
	Top: 0.233	0.299
	Bottom: 0.217	0.248

15 Air Flow: 9.6 CFM per manifold / 19.2 CFM total on sample

Air Temperature: 4.8 degrees Centigrade

Molds: 80 mm dia. Corning #8092 glass

20	Radius	Thickness
	-----	-----
	Concave: 113.22	3.2
	Convex: 78.52	5.2

25

Lens Power:	-1.90 D
Lens Thickness:	2.2 mm
Lens Diameter:	73 mm

30 Gasket: General Electric SE6035 silicone rubber with a 3 mm thick lateral lip dimension and a vertical lip dimension sufficient to provide an initial cavity center thickness of 2.4 mm.

35 Curing: The sample was irradiated for fifteen minutes under the above conditions and removed from the

curing chamber. The molds were separated from the cured lens by applying a sharp impact to the junction of the lens and the convex mold. The lens was then postcured by first exposing it to the low power setting in the UVEXS curing chamber (1.4 seconds each side after demolding). The sample was then placed in the thermal oven for five minutes at 115 degrees Centigrade, removed from the oven, and once again exposed for 1.4 seconds to the postcure UV at the low power setting. It was then returned to the thermal oven for another five minutes at 115 degrees Centigrade. The postcure UV doses were applied first to the convex surface and then to the concave surface for each exposure. For example, if the dose is described as "1.4 sec/low", it means that the front surface of the lens was exposed for 1.4 seconds to the low intensity and then the lens was turned over and the back was exposed for the same length of time at the same intensity level. The impact resistance ("I/R") of each lens was pursuant to ANSI standards, as described for the other examples. The lenses were first tested with a 5/8" diameter steel ball bearing, a 7/8" steel ball bearing, and then a 1" steel ball bearing. The maximum diameter of ball bearing that the sample survived the impact of is described below.

"CR-73" means bispherol A bis(allyl carbonate), "MBZF" means methyl benzoylformate, "Irg. 184" means Irgacure 184.

TABLE 3

Composition	% MBZF	% Irg. 184	Total PI %	Shore D hardness after 1st UV	Final Shore D Hardness	I/R
5 CR-73 20% HDDMA 80%	0.086	0.265	0.351	57	85-86	1"
CR-73 20% TTEGDA 80%	0.0257	0.0064	0.0321	55	70	1"
CR-73 20% TRPGDA 80%	0.025	0.0062	0.031	48	75	1"
10 CR-73 20% TMPTA 80%	0.0461	0.0115	0.0576	50	87	5/8"
TMPTA 90% TRPGDA 10%	0.054	0.014	0.068	72	88	7/8"
15 TRPGDA 90% TMPTA 10%	0.0274	0.0068	0.0342	68-70	82	1"
TMPTA 36.5% HDDMA 24.4% TRPGDA 39.1%	0.096	0.048	0.144	68	87	1"
20 TMPTA 30% HDDMA 10% TRPGDA 60%	0.062	0.021	0.083	67	87	1"
25 TMPTA 30% CR-73 15% TTEGDA 22% TRPGDA 33%	0.0295	0.0074	0.0369	65	85	1"
HDDMA 100%	0.108	0.331	0.439	64-66	86-87	1"
30 HDDMA 94% CR-73 1.14% TMPTA 1.34% TTEGDA 1.41% TRPGDA 2.14%	0.12	0.16	0.28	50	86	1"
TTEGDA 100%	0.01	0.0025	0.0125	58-60	77	1"

	Composition	% MBZF	% Irg. 184	Total PI %	Shore D hardness after 1st UV	Final Shore D Hardness	I/R
5	TTEGDA 98.4% CR-73 0.3% HDDMA 0.2% TMPTA 0.4% TRPGDA 0.6%	0.059	0.015	0.074	70	78	1"
	TRPGDA 100%	0.024	0.006	0.030	66	81-82	1"
10	CR-73 0.13% HDDMA 0.10% TMPTA 0.15% TTEGDA 0.16% TRPGDA 99.5%	0.0238	0.006	0.0244	67	82	1"
	TMPTA 100%	0.058	0.014	0.072	56	89-91	1"
15	TTEGDA 0.38% CR-73 0.31% HDDMA 0.20% TMPTA 98.6% TRPGDA 0.58%	0.056	0.014	0.070	46	87	7/8"
	HDDMA 100%	0.668	--	0.668	45	87	5/8"
	HDDMA 100%	1.215	--	1.215	40	85	5/8"
20	TTEGDA 100%	0.018	--	.018	65	77	1"
	TRPGDA 100%	0.0441	--	.0441	67	80	1"
	TMPTA 100%	0.064	--	0.064	60	87	1"
	TMPTA 100%	0.093	--	0.093	70	91	7/8"
25	CR-73 14.5% TRPGDA 85.5%	0.0377	--	0.0377	60	80	1"
	CR-73 13.6% TMPTA 86.4%	0.074	--	0.074	52	85	1"

Composition	% MBZF	% Irg. 184	Total PI %	Shore D hardness after 1st UV	Final Shore D Hardness	I/R
TMPTA 31.6% TTEGDA 37.2% TRPGDA 16.7% CR-73 14.5%	0.0205	--	0.0205	70	84	1"

5

The initial UV curing time for each lens was 15 minutes, with the exception of the compositions with only TTEGDA with MBZF and Irgacure 184 (which had an initial curing time of 20 minutes), the compositions with only HDDMA and MBZF (which had an initial curing time of 45 minutes), the composition with only CR-73, TMPTA, and MBZF (which had an initial curing time of 20 minutes). The lenses that resulted were generally all water-white optically clear lenses with negligible yellowing and negligible haziness. The 100% TMPTA and 98.6% TMPTA lenses were slightly yellow but otherwise they were the same as the other lenses. These slightly yellow lens formulations may have the yellowness reduced with the addition of an effective amount of Thermoplast Blue added to the formulation.

Generally speaking, the single component (or primarily single component) lenses had generally less preferred optical qualities. Some of these lenses had slight wave patterns in some portions of the lenses.

It is thus seen that the methods, apparatus and compositions of the present invention provide several advantages. For example, according to certain embodiments of the present invention a plastic optical lens can be cured in 30 minutes or less. Furthermore, in certain embodiments of the present invention, the lens

composition includes monomers having a higher refractive index than conventional monomer materials allowing the production of thinner lenses.

5 Although not specifically illustrated in the drawings, it is understood that other additional and necessary equipment and structural components will be provided, and that these and all of the components described above are arranged and supported in an
10 appropriate fashion to form a complete and operative system.

 It is also understood that variations may be made in the present invention without departing from the spirit
15 and scope of the invention. Of course, other variations can be made by those skilled in the art without departing from the invention as defined by the appended claims.

CLAIMS:

1. A method for making a plastic lens, comprising the steps of:

5

placing a polymerizable lens forming material in a mold cavity defined in part between a first mold member and a second mold member;

10

directing ultraviolet rays towards at least one of the first or second mold members; and

cooling the first mold member and the second mold member with a fluid at a temperature of between
15 0°C and less than 20°C.

2. The method of claim 1 wherein the fluid is air.

20

3. The method of claim 1 wherein the fluid temperature is about 0-15°C.

25

4. The method of claim 1 wherein the fluid temperature is about 0-10°C.

30

5. The method of claim 1 wherein the fluid temperature is about 3-8°C.

35

6. The method of claim 1 wherein the mold cavity is substantially cylindrical and the height of the cavity varies across the diameter of the cavity; and wherein the

intensity of the ultraviolet rays is varied approximately in proportion to the height of the cavity.

5 7. The method of claim 1 wherein the first and second mold members each have a face, and the fluid is directed toward the face of the first mold member, and toward the face of the second mold member.

10

8. The method of claim 1 wherein the first and second mold members each have a center and edges, and the fluid is directed from the edges of the first mold member to the center of the first mold member, and from the edges
15 of the second mold member to the center of the second mold member.

9. A method for making a plastic lens, comprising the
20 steps of:

placing a polymerizable lens forming material in a mold cavity defined in part between a first mold member and a second mold member;

25

directing ultraviolet rays towards at least one of the first and second mold members; and

contacting air at a rate of about 1-30 standard
30 cubic feet (about 0.028-0.850 standard cubic meters) per minute toward the first mold member to cool the first mold member, and contacting air at a rate of about 1-30 standard cubic feet (about 0.028-0.850 standard cubic meters) per
35 minute toward the second mold member to cool the second mold member.

10. The method of claim 9 wherein the rate of air contacting the first mold member is about 4-20 standard cubic feet (about 0.113-0.566 standard cubic meters) per minute, and the rate of air contacting the second mold member is about 4-20 standard cubic feet (about 0.113-0.566 standard cubic meters) per minute.

11. The method of claim 9 wherein the rate of air contacting the first mold member is about 9-15 standard cubic feet (about 0.255-0.423 standard cubic meters) per minute, and the rate of air contacting the second mold member is about 9-15 standard cubic feet (about 0.255-0.423 standard cubic meters) per minute.

15

12. A method for making a plastic lens, comprising the steps of:

placing a polymerizable lens forming material in a mold cavity defined in part between a first mold member with a thickness of about 1.0-5.0 mm and a second mold member with a thickness of about 1.0-5.0 mm;

directing ultraviolet rays towards at least one of the first and second mold members; and

contacting fluid against the first or second mold member to cool the first or second mold member.

30

13. The method of claim 12 wherein the first or second mold member has a thickness of about 2.0-4.0 mm.

35

14. The method of claim 12 wherein the first or second mold member has a thickness of about 2.5-3.5 mm.

5 15. A method for making a plastic lens with a desired curvature, comprising the steps of:

10 placing a polymerizable lens forming material in a mold cavity defined in part between a first mold member and a second mold member, and wherein the cavity defines a theoretical curvature that is different from the desired curvature;

15 directing ultraviolet rays towards at least one of the first and second mold members, and wherein the ultraviolet rays are directed towards the first or second mold member such that the material cures to form a lens with the desired curvature; and
20

contacting fluid against the first or second mold member to cool the first or second mold member.

25 16. The method of claim 15, further comprising the additional steps of demolding the lens, and heating the lens.

30 17. The method of claim 16 wherein the heating forms the lens with the desired curvature.

35 18. The method of claim 15 wherein the intensity of the ultraviolet rays is varied across the first or second

mold members such that the material cures to form the lens with the desired curvature.

- 5 19. A method for making a plastic lens, comprising the steps of:

10 placing a polymerizable lens forming material in a mold cavity defined in part between a first mold member and a second mold member;

15 directing first ultraviolet rays toward at least one of the mold members to cure the material to a lens;

contacting fluid against the first or second mold member to cool the first or second mold member;

20 demolding the lens from at least one mold member;

directing second ultraviolet rays towards the lens;

heating the lens.

- 25 20. The method of claim 19, further comprising the additional step of directing third ultraviolet rays towards the lens.

- 30 21. The method of claim 20, further comprising the additional step of heating the lens after the third ultraviolet rays are directed towards the lens.

35

22. The method of claim 19 wherein the total intensity of the first ultraviolet rays on the mold members is less than about 10 mW/cm².

5

23. The method of claim 19 wherein the lens is heated to a temperature of about 65-180°C.

10 24. The method of claim 19 wherein the lens is heated for less than about 30 minutes.

15 25. The method of claim 19 wherein the intensity of the second ultraviolet rays is about 150-300 mW/cm² at a wavelength range of about 360-370 nm, and about 50-150 mW/cm² at a wavelength range of about 250-260 nm.

20 26. The method of claim 19 wherein the second ultraviolet rays are directed at the lens for less than about 1 minute.

25 27. The method of claim 20 wherein the intensity of the third ultraviolet rays is about 150-300 mW/cm² at a wavelength range of about 360-370 nm, and about 50-150 mW/cm² at a wavelength range of about 250-260 nm.

30

28. The method of claim 20 wherein the third ultraviolet rays are directed at the lens for less than about 1 minute.

35

29. The method of claim 21 wherein the lens is heated to a temperature of about 65-180°C after the third ultraviolet rays are directed towards the lens.

5

30. The method of claim 21 wherein the lens is heated for less than about 30 minutes after the third ultraviolet rays are directed towards the lens.

10

31. A method for making a plastic lens, comprising the steps of:

15

placing a polymerizable lens forming material in a mold cavity defined in part between a first mold member and a second mold member separated by an annular gasket;

20

directing rays of ultraviolet light through the annular gasket to cure the lens forming material.

25

32. The method of claim 31, further comprising the step of preventing rays of ultraviolet light from impinging against the first or second mold members.

30

33. Apparatus for making a plastic lens, comprising:

a first mold member;

35

a second mold member spaced apart from the first mold member, and the first and second mold members defining a mold cavity;

an ultraviolet light generator for generating and directing ultraviolet light toward at least one of the first and second mold members during use;

5

an ultraviolet light filter disposed between the ultraviolet light generator and the first mold member, and between the ultraviolet light generator and the second mold member; and

10

a distributor for directing cooling fluid at a temperature of between 0°C and less than 20°C toward the first and second mold members during use.

15

34. The apparatus of claim 33 wherein the fluid is air.

20 35. The apparatus of claim 33 wherein the fluid temperature is about 0-15°C.

25 36. The apparatus of claim 33 wherein the fluid temperature is about 0-10°C.

30 37. The apparatus of claim 33 wherein the fluid temperature is about 3-8°C.

35 38. The apparatus of claim 33 wherein the mold cavity is cylindrical and the height of the cavity varies across the diameter of the cavity.

-91-

39. The apparatus of claim 38 wherein the filter is positioned to direct ultraviolet light during use with an intensity that varies in proportion to the height of the cavity.

5

40. The apparatus of claim 33 wherein the mold members each have a face, and wherein the distributor is connected to distribute fluid during use towards the faces of the mold members.

10

41. The apparatus of claim 33 wherein the mold members each have a face with edges, and wherein the distributor is connected to distribute fluid during use from the edges of the first mold member to the center of the first mold member, and from the edges of the second mold member to the center of the second mold member.

15

20

42. The apparatus of claim 33 wherein the filter comprises a disk of opaque material for reducing the intensity of ultraviolet light reaching the center of the mold members relative to the intensity of ultraviolet light reaching the edge of the mold members during use.

25

43. The apparatus of claim 33 wherein the filter comprises a ring of opaque material for reducing the intensity of ultraviolet light reaching the edge of the mold members relative to the intensity of ultraviolet light reaching the center of the mold members during use.

30

44. The apparatus of claim 33 wherein the filter comprises a transparent sheet material having a plurality of ultraviolet light absorbing shapes printed thereon.

5

45. The apparatus of claim 44 wherein the density per unit area of the shapes is at a minimum at a point corresponding to the greatest distance between the first mold member and the second mold member and wherein the
10 density per unit area of the shapes is at a maximum at a point corresponding to the smallest distance between the first mold member and the second mold member.

15 46. The apparatus of claim 33 wherein the distributor comprises an air jet having a substantially cylindrical bore, and the bore has a plurality of openings disposed about the circumference thereof.

20

47. The apparatus of claim 46 wherein the average diameter of the openings in the air jet varies about the circumference of the bore.

25

48. The apparatus of claim 46 wherein the air jet comprises an air inlet and the diameter of the openings is at a minimum adjacent the air inlet, and the diameter of the openings is at a maximum at a point along the
30 circumference of the bore that is opposite the bores having a minimum diameter.

35

49. Apparatus for making a plastic lens, comprising:

a first mold member;

- a second mold member spaced apart from the first mold member, and the first and second mold members defining a mold cavity;
- 5 an ultraviolet light generator for generating and directing ultraviolet light towards at least one of the first and second mold members during use;
- 10 an ultraviolet light filter disposed between the ultraviolet light generator and the first mold member, and between the ultraviolet light generator and the second mold member; and
- 15 a distributor adaptable to direct during use about 1-30 standard cubic feet (about 0.028-0.850 standard cubic meters) per minute toward the first mold member to cool the first mold member, and about 30 standard cubic feet (about
- 20 0.028-0.850 standard cubic meters) per minute toward the second mold member to cool the second mold member.
- 25 50. The apparatus of claim 49 wherein the distributor is adaptable to direct during use about 4-20 standard cubic feet (about 0.113-0.566 standard cubic meters) per minute towards the first mold member to cool the first mold member, and about 4-20 standard cubic feet (about 0.113-
- 30 0.566 standard cubic meters) per minute towards the second mold member to cool the second mold member.
- 35 51. The apparatus of claim 49 wherein the distributor is adaptable to direct during use about 9-15 standard cubic feet (about 0.255-0.423 standard cubic meters) per minute

towards the first mold member to cool the first mold member, and about 9-15 standard cubic feet (about 0.255-0.423 standard cubic meters) per minute towards the second mold member to cool the second mold member.

5

52. Apparatus for making a plastic lens, comprising:

10 a first mold member with a thickness less than about 5.0 mm;

15 a second mold member with a thickness less than about 5.0 mm spaced apart from the first mold member, and the first and second mold members defining a mold cavity;

20 an ultraviolet light generator for generating and directing ultraviolet light towards at least one of the first and second mold members during use;

25 an ultraviolet light filter disposed between the ultraviolet light generator and the first mold member, and between the ultraviolet light generator and the second mold member; and

30 a distributor for directing cooling fluid towards the first and second mold members during use.

30

53. The apparatus of claim 52 wherein the mold members have a thickness of about 2.0-4.0 mm.

35 54. The apparatus of claim 52 wherein the mold members have a thickness of about 2.5-3.5 mm.

55. System for making a plastic lens, comprising:

an apparatus for making a plastic lens, comprising:

5

a first mold member;

10

a second mold member spaced apart from the first mold member, and the first and second mold members defining a mold cavity;

15

a first ultraviolet light generator for generating and directing ultraviolet light towards at least one of the first and second mold members during use;

20

an ultraviolet light filter disposed between the first ultraviolet light generator and the first mold member, and between the first ultraviolet light generator and the second mold member; and

25

a distributor for directing cooling fluid towards the first and second mold members during use;

30

a second ultraviolet light generator for generating and directing ultraviolet light towards the lens during use; and

a first heater to heat the lens during use.

35 56. The system of claim 55, further comprising a third ultraviolet light generator for generating and directing

ultraviolet light against the lens during use after the lens has been heated.

5 57. The system of claim 56, further comprising a second heater to heat the lens during use after the third ultraviolet light generator has directed light against the lens.

10

58. A photoinitiator for lens forming compositions comprising methyl benzoylformate.

15 59. The photoinitiator of claim 58, further comprising 1-hydroxycyclohexyl phenyl ketone.

20 60. A polymerizable lens forming composition comprising at least one polyethylenic-functional monomer containing two ethylenically unsaturated groups selected from acrylyl and methacrylyl, and methyl benzoylformate.

25 61. The composition of claim 60, further comprising an aromatic containing bis(allyl carbonate)-functional monomer.

30 62. A polymerizable lens forming composition comprising at least one polyethylenic-functional monomer containing three ethylenically unsaturated groups selected from acrylyl and methacrylyl, and methyl benzoylformate.

35

63. The composition of claim 62, further comprising an aromatic containing bis(allyl carbonate)-functional monomer.

5

64. A polymerizable lens forming composition comprising bisphenol A bis(allyl-carbonate), 1,6 hexanediol dimethacrylate, tetraethylene glycol diacrylate, tripropylene glycol diacrylate, trimethylolpropane
10 triacrylate, and methyl benzoylformate.

65. The composition of claim 60, comprising up to about 1.2 percent by weight of methylbenzoyl formate.

15

66. The composition of claim 60, comprising up to about 0.015-0.05 percent by weight of methyl benzoylformate.

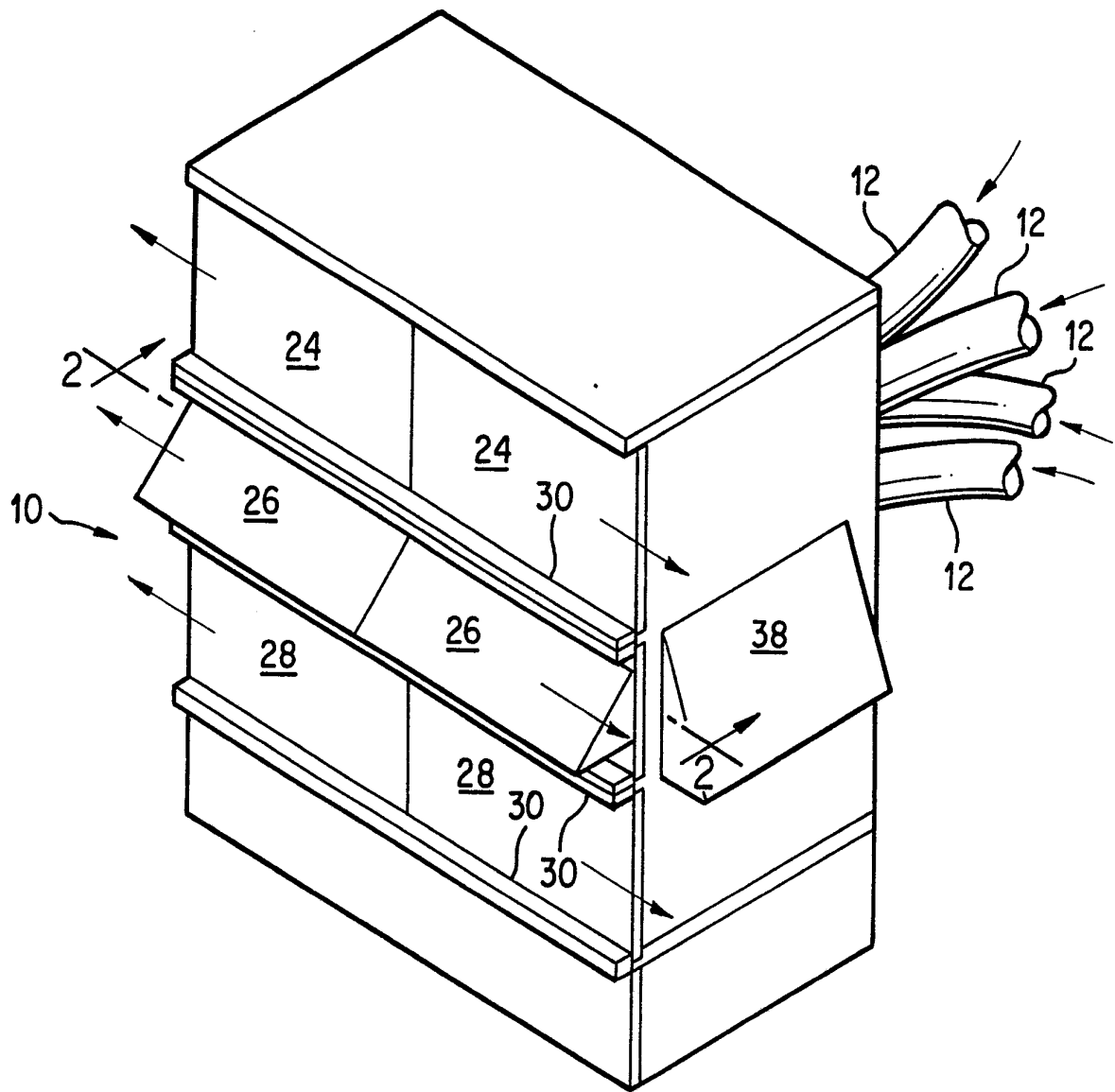

FIG. 1

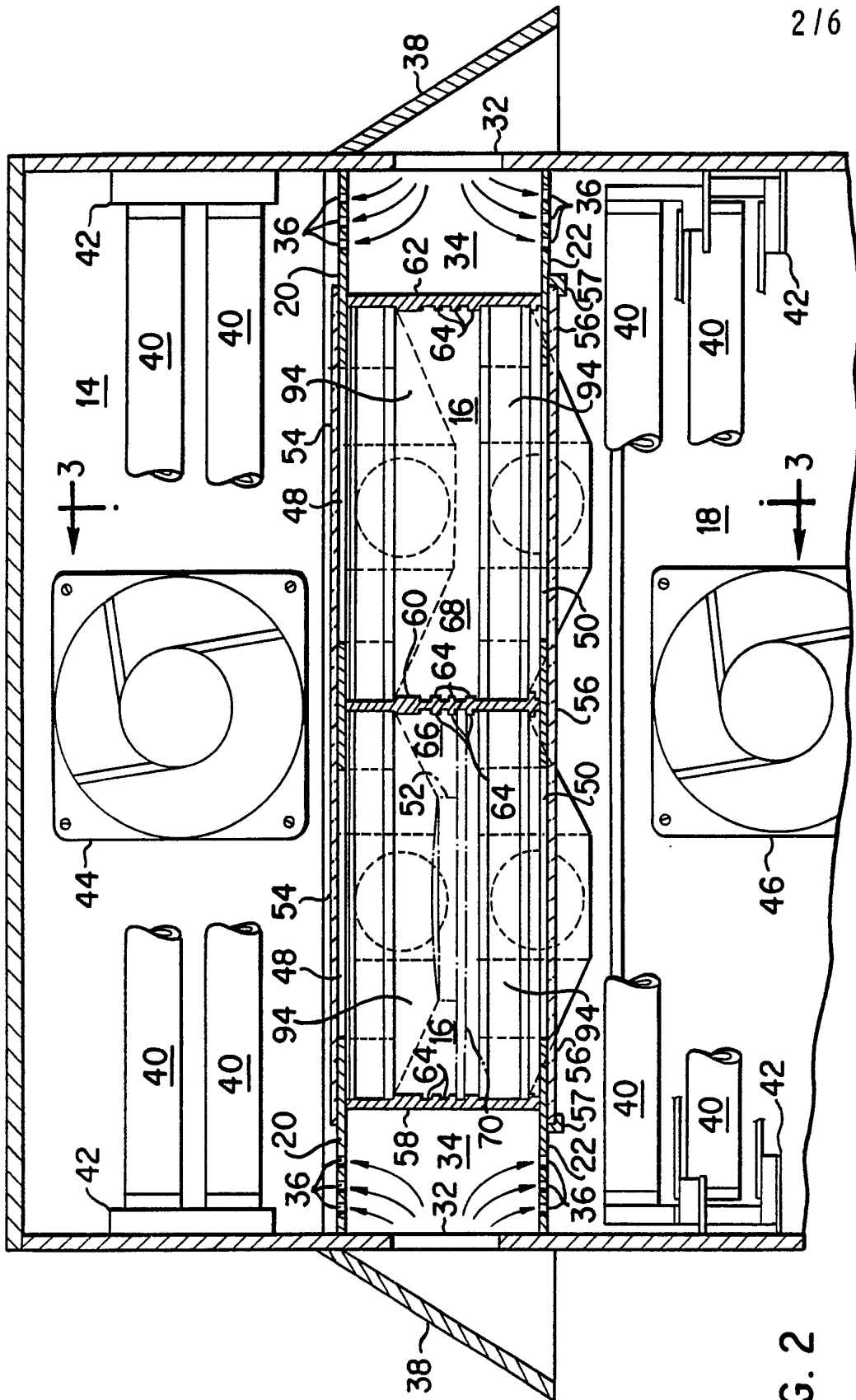

FIG. 2

3/6

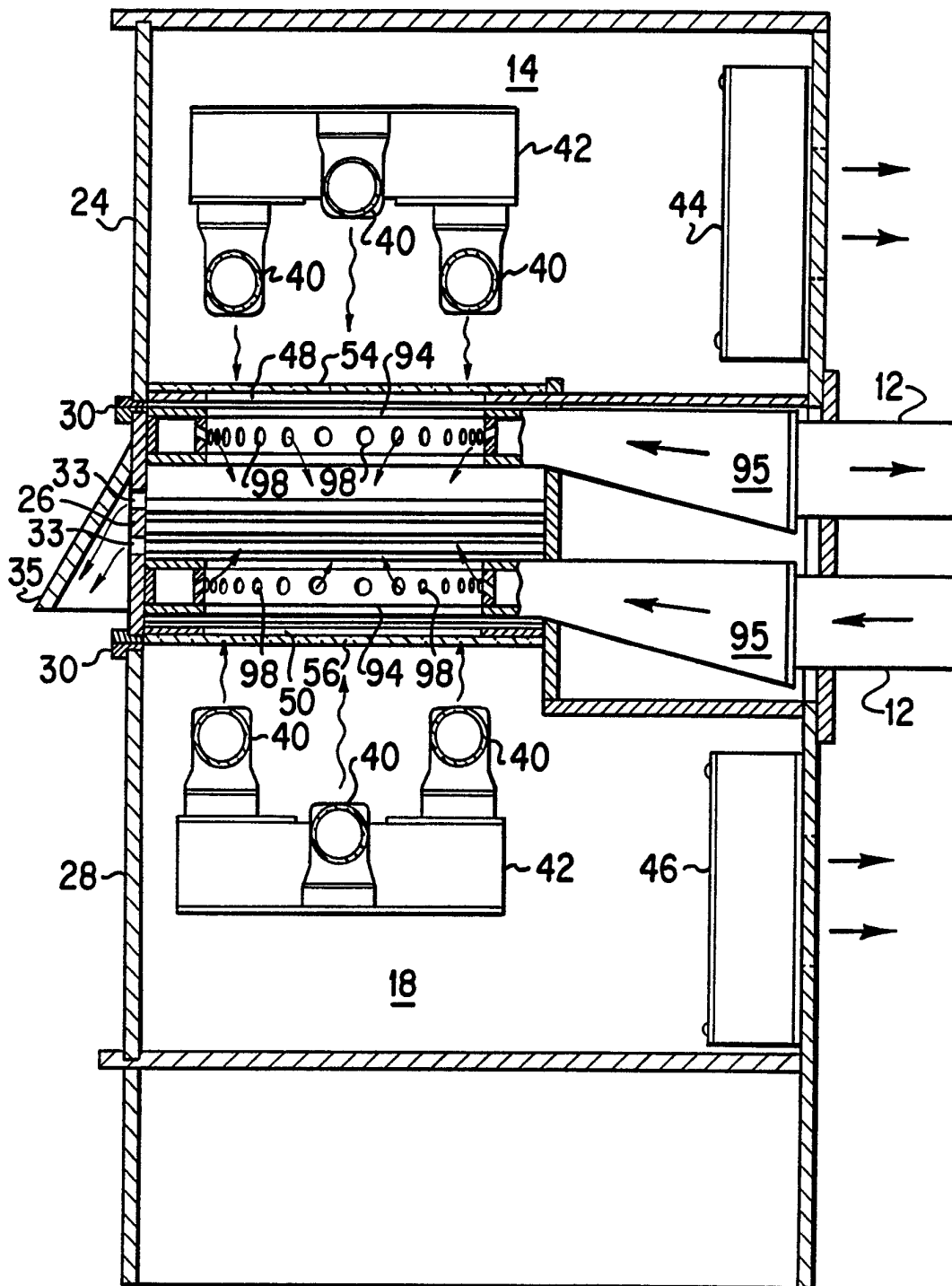

FIG. 3

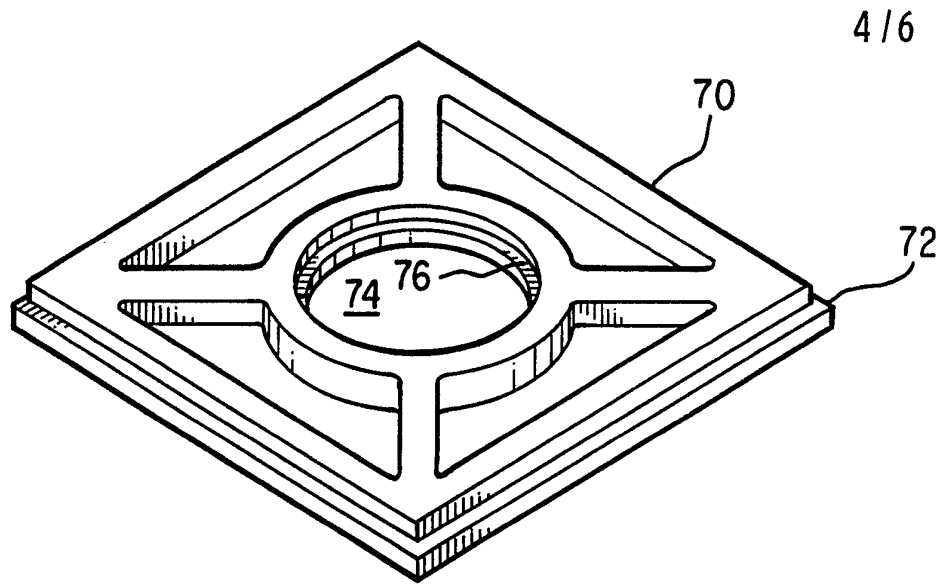

FIG. 4

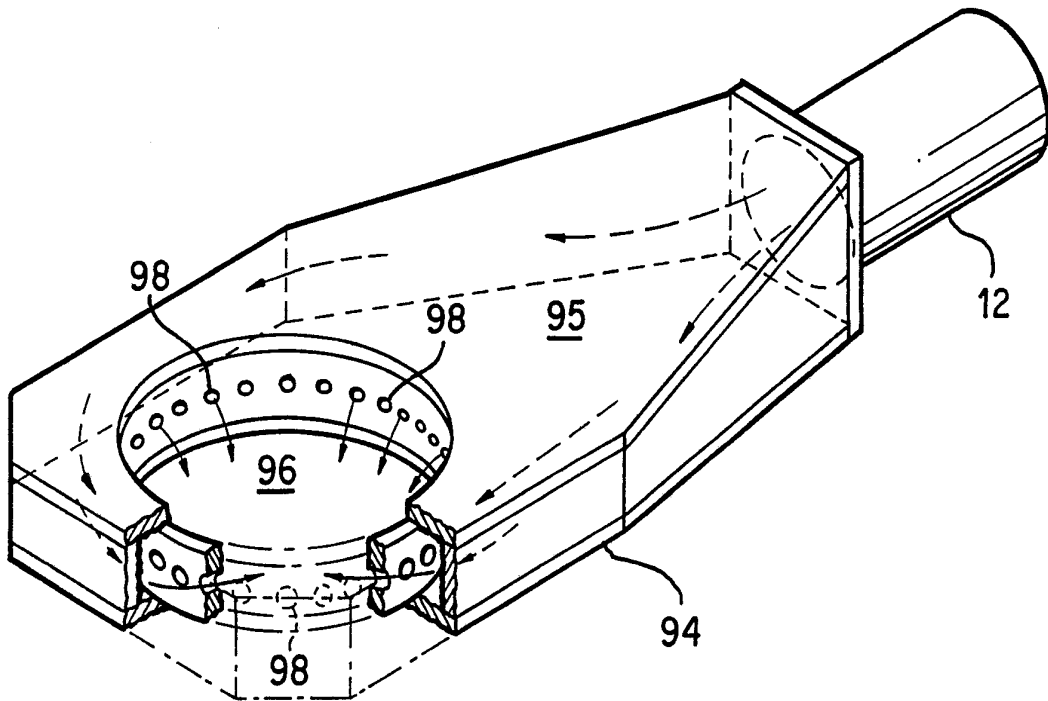

FIG. 5

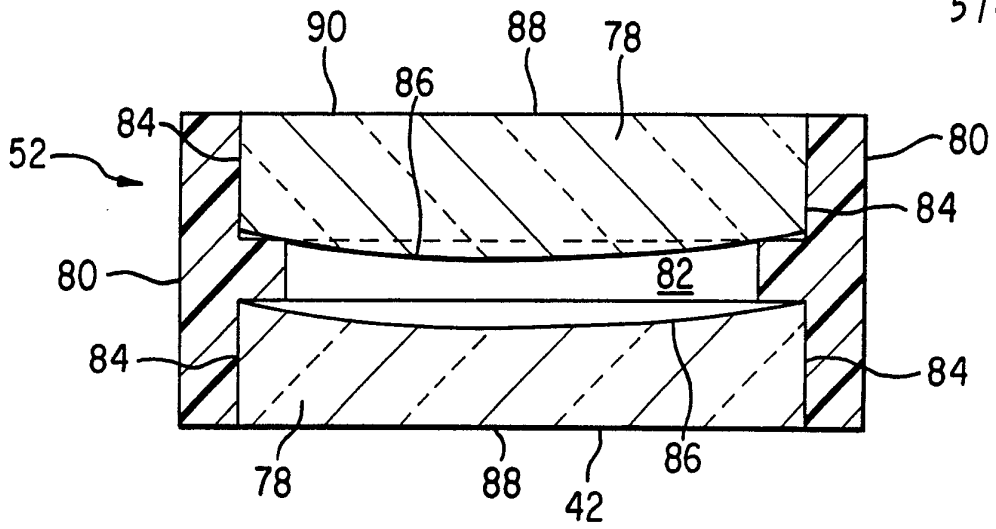

FIG. 6

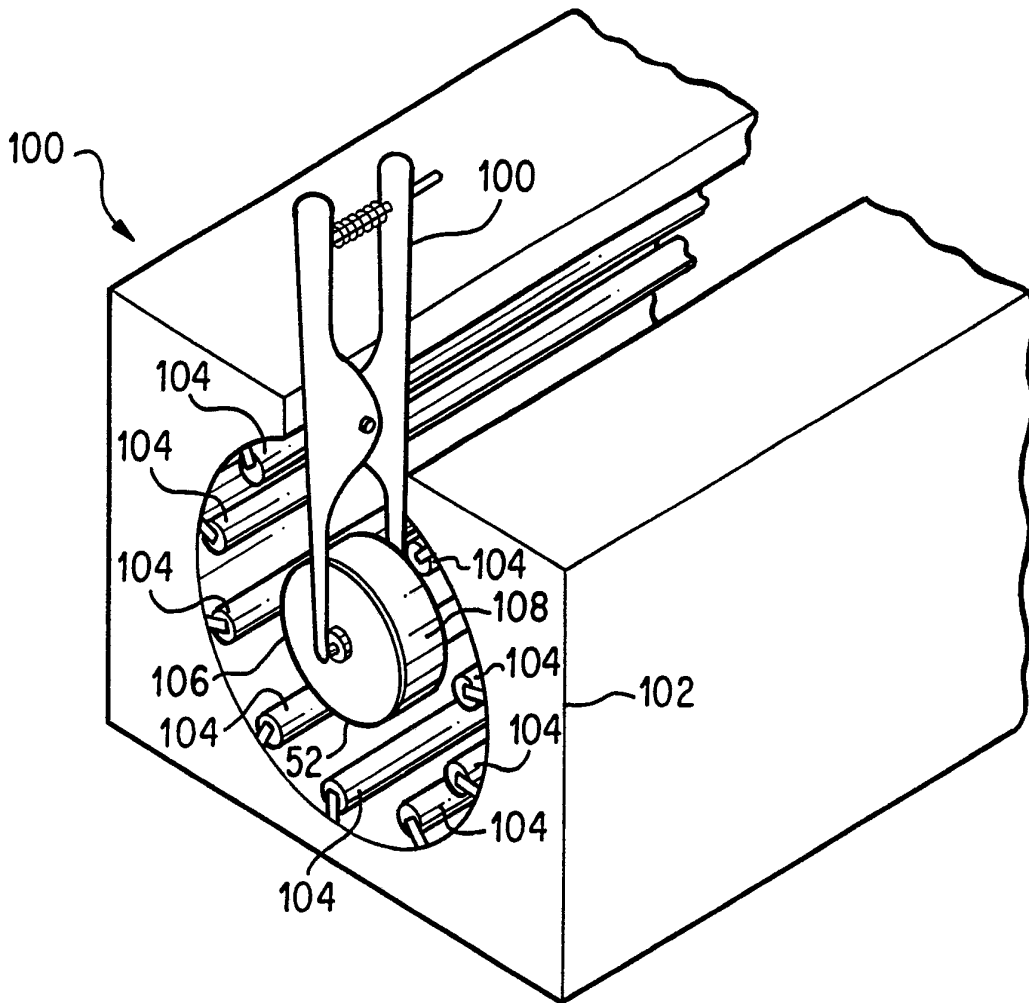

FIG. 7

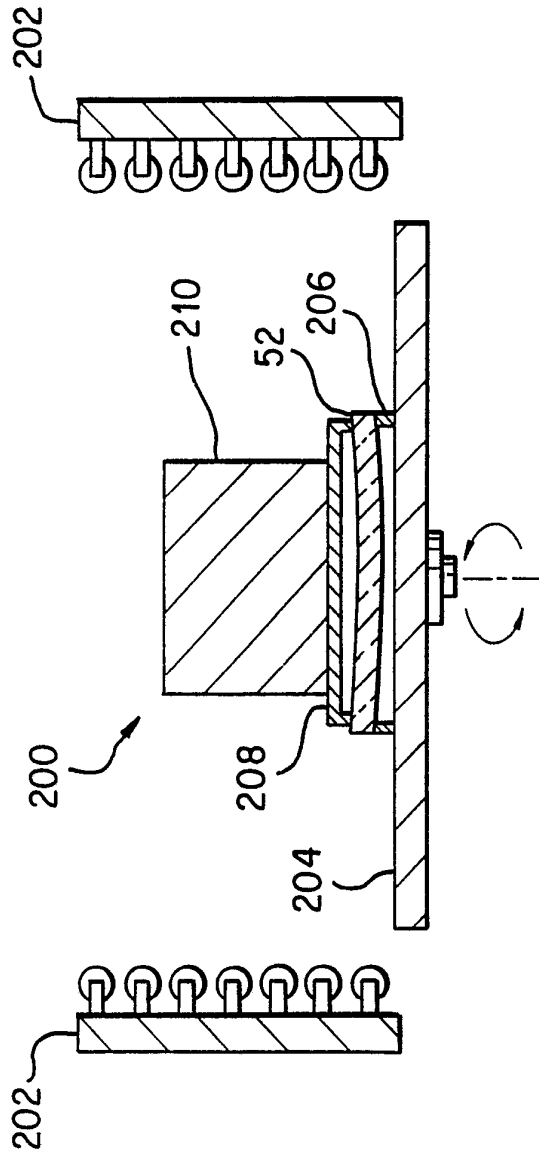

FIG. 8

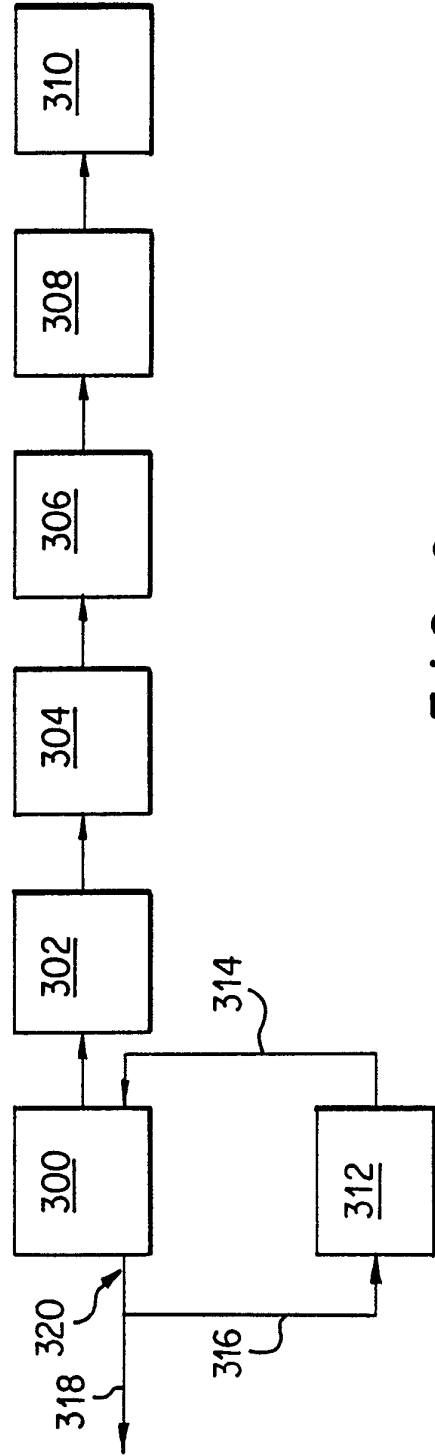

FIG. 9