



(51) International Patent Classification:

*H02S 10/12* (2014.01)      *H02S 40/10* (2014.01)  
*F03D 3/04* (2006.01)      *H02S 40/42* (2014.01)  
*H02S 20/24* (2014.01)

(21) International Application Number:

PCT/NL2022/050528

(22) International Filing Date:

21 September 2022 (21.09.2022)

(25) Filing Language:

English

(26) Publication Language:

English

(30) Priority Data:

2029487                      21 October 2021 (21.10.2021)      NL

(71) Applicant: **IBIS POWER HOLDING B.V.** [NL/NL];  
Klokgebouw 155, 5617AB Eindhoven (NL).

(72) Inventor: **SUMA, Alexander Boudewijn**; Klokgebouw  
155, 5617AB Eindhoven (NL).

(74) Agent: **VAN DER VELDEN, Marc**; Sportweg 6, 2751ER  
Moerkapelle (NL).

(81) Designated States (*unless otherwise indicated, for every kind of national protection available*): AE, AG, AL, AM, AO, AT, AU, AZ, BA, BB, BG, BH, BN, BR, BW, BY, BZ, CA, CH, CL, CN, CO, CR, CU, CV, CZ, DE, DJ, DK, DM, DO, DZ, EC, EE, EG, ES, FI, GB, GD, GE, GH, GM, GT, HN, HR, HU, ID, IL, IN, IQ, IR, IS, IT, JM, JO, JP, KE, KG, KH, KN, KP, KR, KW, KZ, LA, LC, LK, LR, LS, LU, LY, MA, MD, ME, MG, MK, MN, MW, MX, MY, MZ, NA, NG, NI, NO, NZ, OM, PA, PE, PG, PH, PL, PT, QA, RO, RS, RU, RW, SA, SC, SD, SE, SG, SK, SL, ST, SV, SY, TH, TJ, TM, TN, TR, TT, TZ, UA, UG, US, UZ, VC, VN, WS, ZA, ZM, ZW.

(84) Designated States (*unless otherwise indicated, for every kind of regional protection available*): ARIPO (BW, GH, GM, KE, LR, LS, MW, MZ, NA, RW, SD, SL, ST, SZ, TZ, UG, ZM, ZW), Eurasian (AM, AZ, BY, KG, KZ, RU, TJ, TM), European (AL, AT, BE, BG, CH, CY, CZ, DE, DK, EE, ES, FI, FR, GB, GR, HR, HU, IE, IS, IT, LT, LU, LV,

(54) Title: DEVICE FOR GENERATING RENEWABLE ENERGY

Fig. 1

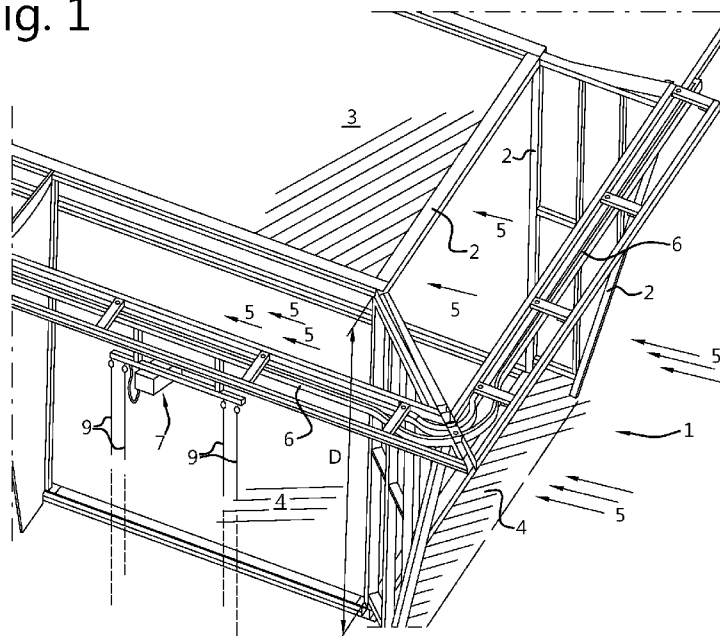

(57) Abstract: Device for generating renewable energy, comprising a carrying structure (2) for positioning a surface (3) with solar panels at a distance (D) from a support (4), in particular the roof of a building, an air duct (5), defined in height direction by the support and the surface, wherein the surface area protrudes at least partially and preferably completely beyond the support area, wherein the carrying structure comprises a displacement system (6) for a mover (7) for a maintenance device (8), such as a gondola, which displacement system is designed for displacing the mover at least partly along that part of the surface that projects outside the support.



MC, MK, MT, NL, NO, PL, PT, RO, RS, SE, SI, SK, SM,  
TR), OAPI (BF, BJ, CF, CG, CI, CM, GA, GN, GQ, GW,  
KM, ML, MR, NE, SN, TD, TG).

**Published:**

— *with international search report (Art. 21(3))*

**Device for generating renewable energy**

The present invention relates to a device for generating renewable energy, in particular a device of that kind for integration on a rooftop of a building, as well as a building provided with such device.

- 5 Devices of this type are known in the art and have been proposed by the applicant in various forms. Amongst those are the ones described in the international patent application PCT/NL/2017/00359 and PCT/NL/2019/050506, which have appeared to have an excellent performance, and which have an ever-growing commercial success.

10 Limitations to apply the invention therefore do not lie in the properties of the proposed system, but in limitations imposed by the environment, in particular the buildings to which the invention is to be applied.

One of the limitations is that rooftops may already have functional applications and/or devices, that occupy a part of their surface. Some of these items may allow to be covered or in particular to have an array of solar panels on top of them. Others don't and among the latter  
15 ones are maintenance devices for the building walls, especially (window) cleaning apparatus. These apparatuses usually comprise a gondola type of carrier for personnel, which needs to be movable along the wall surface. For that purpose, these systems comprise a system that extends along the edges of the roof and allows the gondola to be moved. In general, a cabinet with control and additional technical devices for lifting the gondola occupies a central part of  
20 the roof, impeding placement of a device for generating renewable energy of the type according to the above cited prior art.

It is a goal of the present invention to take away the above-mentioned disadvantages, or at least to provide a useful alternative to the prior art.

25 The invention thereto proposes a device for generating renewable energy, comprising a carrying structure for positioning a surface with solar panels at a distance from a support, in particular the roof of a building, an air duct, defined in height direction by the support and the surface, wherein the surface area protrudes at least partially and preferably completely beyond the support area and the carrying structure comprises a displacement system for a mover for a maintenance device, such as a gondola, which displacement system is designed for displacing  
30 the mover at least partly along that part of the surface that projects outside the support. The

displacement system may normally be arranged at a bottom side of the surface with solar panels.

More in particular the device according to the invention may – combined or not with other features mentioned in this application - comprise an electric power system for converting  
5 wind energy into electric energy, comprising a duct for air, the duct comprising a floor, a first and a second wall, a roof, and the duct further defining an air inflow direction towards a turbine, the turbine having a diameter, and being located adjacent to or at least partially in the duct; and defining together with the duct an air outflow direction, wherein an area free of  
10 pressure or turbulence increasing obstructing elements, extending in the resultant air outflow direction of the turbine over a length of at least one, and preferably more than two times the turbine diameter, measured from the centre of rotation of the turbine.

The floor and the roof may in a practical embodiment for instance be oriented essentially perpendicular to the walls, so that a tube with an essentially square cross section is obtained, but multiple shapes and configurations are thinkable.

15 The turbine may be any type of turbine, both with wicks extending parallel to its axis of rotation, which may be vertical or horizontal. In such cases, the axis of rotation is also the centre of rotation. The turbine may also have wicks extending from its axis of rotation, which in that case will be horizontal. In this (propeller type) case the origin at the axis of rotation from where the wicks extend will be the centre of rotation.

20 The duct may have a throughput area that decreases downstream, for converging and thus focussing the air flow, causing a higher speed inside the duct, which is beneficial for the power transfer to the turbine. However, after the turbine, for an optimal air flow, that is an air outflow that as a whole encounters the least resistance, it is important that, no more pressure increase takes place.

25 For that reason, an area free of pressure increasing obstructing elements, extending in the air outflow direction of the turbine over a length of at least one, and preferably more than two times the turbine diameter, and mostly preferred over a length of about three times the turbine diameter measured from the centre of rotation of the turbine may be provided. It has been determined by the applicant, that an area free of pressure increasing obstructing elements  
30 extending more than three times the turbine diameter does not improve the performance anymore.

Pressure increasing obstructing elements are to be understood as elements that cause at least a locally increased pressure, for instance because they impede a free air flow, or because they form a course of turbulence.

5 In many state of the art solutions, in particular those with turbines with vertical axis of rotation, walls are present around the turbine. Although they are generally considered as beneficial for creating a duct for every direction of incoming wind, when optimising for just one direction, according to the present invention they are found to have disadvantages.

10 In a further embodiment, the system according to the invention comprises a pressure decreasing element, such as a diffuser, arranged in the area free of pressure increasing obstructing elements. Such diffuser generally consists of sharp edged rounded blades (for instance having an almond or canoe shaped cross section), diverging an air flow without obstructing it. The beneficial effect of such diffuser is that it causes a (local) pressure decrease, which contributes to the desired optimal air flow.

15 In practice, the floor and the roof are oriented essentially horizontal in use, and the walls are oriented essentially vertical in use. A housing may be formed, being adapted for placement on the roof of a building. Said housing, and in particular the floor and the roof may be essentially rectangular, and in a particular embodiment square. In a preferred embodiment, the floor has a rectangular shape, with measurements of about 6 x 3 meters, wherein the axis of rotation of the turbine is oriented in the middle of one of the long sides.

20 The walls may be straight panels, put it is also thinkable that at least one of the walls is curved or folded, in order to reduce turbulence.

The combination of the floor, roof and walls forming the duct and the placement of the turbine with respect to the duct lead to a concentration of wind toward the turbine and as a result to an increased wind velocity through a venturi effect and increased power generation.

25 In a further embodiment, the walls extend under a respective first angle and second angle with respect to a line connecting their starting points, wherein the first angle lies between 45 and 90 degrees, and wherein the second angle lies between 25 and 65 degrees. This way the system according to the invention can be optimized for different dominant wind directions before it is actually mounted at site.

30 A duct can be thus formed that leads the wind towards one side of the turbine, while the other is – at least for wind coming from the same direction - covered by one of the walls. In a

turbine with a vertical axis, it is important to concentrate the wind to one site in which the blades of the turbine are oriented such that they catch the maximum amount of wind, while in the other orientation, when they should move against the wind, they are covered as much as possible.

- 5 It has appeared, that optimal results are obtained when the first angle and the second angle are together 90 degrees.

In a further embodiment, the side of the floor facing the roof is inclined, going upward from its edge inwardly, over a distance smaller than the distance from the edge to the turbine.

- 10 An advantage of this feature is that it reduces turbulence at the roof edge so that the air flow is more steady at the turbine, because a smoother entrance to the system is created, decreasing turbulence and leading to a more stable operation of the system, in particular when the system according to the invention is applied on the roof of a (high) building, whereby part of the wind or air is deflected by the building facade and thus obtains a directional component upwardly.

- 15 The turbulence reducing effect can be further increased when also the side of the roof facing the floor is inclined, going downward from its edge inwardly, over a distance smaller than the distance from the edge to the turbine. In particular, the angle under which the roof is inclined toward the floor may be between 15 and 20 degrees.

- 20 The system according to the invention may further comprise at least one louver, extending between the first and the second wall, and inclined upwardly in a direction toward the turbine. The louver may for example be under an angle between 5 and 30 degrees with the horizontal.

- 25 Such louver also contributes to a more homogeneous direction of the incoming air directing on turbine. In a practical embodiment, the system according to the invention comprises two louvers, wherein a first louver, arranged above the floor, is inclined at an angle between 20 and 30 degrees, and a second louver, arranged between the first louver and the roof, is inclined at an angle between 5 and 15 degrees.

In a further aspect of the present invention, the roof extends over the floor in a direction away from the turbine.

- 30 This has the advantage of capturing air with an upward component, but also enlarges the roof surface, which may be beneficial for further purposes, for instance for placing solar panels on

top of the roof of the system. The duct may in that case be configured for guiding air along the bottom side of the solar panels, for cooling the latter.

The direction from the edge of the floor to the edge of the roof may extend at an angle between 5 and 20, and in particular between 8 and 12 degrees from a direction perpendicular to the plane in which the roof or the floor lays. It has appeared that with these angles, optimum points of catching mass flow from façade are obtained.

Another aspect of the present invention is that the cross section of the duct decreases in a direction toward the turbine. Herewith, locally a higher air speed is obtained, which leads to a higher rotational speed of the turbine for a given wind force, and thus to a higher power generation. Preferably the cross section decreases between 1 and 3 times.

A further aspect of the invention comprises a deflector, arranged between the first wall and the second wall. The deflector may be movable. Herewith, instead of placing the walls in different angles, similar effect can be reached by placing a deflector before the turbine. The blade is, coming towards the edge of the building protected from the wind.

More in particular the device according to the invention may – combined or not with other features mentioned in this application - relate to a solar panel system, comprising an array of solar panels, the array essentially arranged parallel to and a distance from the plane of a substantially flat support surface, such as a roof or the sea surface, each solar panel inclined with respect to the array and thus to the flat surface, at least one air inlet, between the support surface and the array and at least one air outlet between adjacent solar panels in the array, wherein a duct for air is formed from the air inlet to the at least one air outlet, by at least two walls that extend from the support surface to the array and flank the space defined between the support surface and the array. Preferably all solar panels are equipped with an air outlet between adjacent solar panels.

By providing the solar panels at a distance from the support surface, a space is created between the solar panels and the support, through which space air is enabled to flow. The air is guided from the air inlet to the at least one air outlet, by the duct formed by the support surface, the walls, and the surfaces of the solar panels themselves. In most cases, this duct may thus have a tubular shape, with an essentially rectangular cross section in the direction of air flow. The bottom side of the solar panels may thus be uncovered, in order to allow air to flow along them directly.

The air flow itself is automatically created, by ambient air pressure and local weather conditions. In particular when the solar panel system according to the present invention is arranged on a rooftop of building that is higher than its surroundings, or for instance floating on the sea, an air flow is easily obtained. When positioning the system according to the invention on a rooftop, the air inlet may evidently be positioned toward the direction from  
5 where wind is blowing in general. The solar panel array structure may extend over the façade or wall of the hosting structure so that more wind flow is captured to be directed inward.

In a preferred embodiment, the duct may be essentially or completely closed, except for the air inlet and the at least one air outlet.

10 In that case, the air outlet between adjacent solar panels and the outlet between the support surface and the array are the sole outlets for air. Such configuration ensures that the entire air flow is directed toward the air outlet between adjacent solar panels, or in case its present, also partly through the air outlet between the support surface and the array.

When the solar panel system according to the invention comprises an air outlet between the support surface and the array, an airflow through the duct may be created, that may be used  
15 for generating electric power when a generator is arranged in the duct. Otherwise, the outlet may provide the advantage that the risk of airflow that becomes too high is limited, or that the airflow can even be controlled when the area of the outlet opening is variable. Such air outlet between the support surface and the array may preferably be arranged at the opposite side  
20 from air inlet.

In a further embodiment of the present invention, the air inlet may have a spoiler that directs wind toward the at least one air outlet between adjacent solar panels, or, if several outlets between adjacent panels are available, toward those several outlets. Such spoiler may for instance be inclined with respect to the support, and in particular be directed to the array of  
25 solar panels, to guide the air along the bottom surfaces of the solar panels.

In an advanced embodiment, the spoiler is movable in order to amend the angle of inclination. It may for instance be rotatable with respect to an axis of rotation, that may essentially coincide or lie in the plane of the support surface. The spoiler itself may comprise a plane, flat or curved, for deflecting the air flow. The solar panel system may further be configured for  
30 adjusting the angle the spoiler has with respect to the support surface in dependence of the speed or force of air at the air inlet. A configuration for adjusting the angle for instance comprises a spring, configured and or directed to increase the angle of inclination when no

force is exerted by an incoming air flow. The stronger the air flow, the smaller the angle, so that the air is less directly forced toward the solar panels.

The solar panel system may also comprise a second spoiler at the air outlet between the support surface and the array. Such second spoiler may also be used to control the amount of mass flow or in particular the fraction of air that passes through the duct to the air outlet  
5 between the support surface and the array, and the amount or fraction that passes through the air outlets between adjacent solar panels. Solar panel system according to claim 9, wherein the second spoiler is movable between a first position wherein air flow through the outlet opening is allowed and a second position wherein air flow is prohibited in order to force air to  
10 flow out via the at least one outlet between adjacent solar panels in the array.

In embodiments where the solar panel system according to the invention comprises multiple air outlets between adjacent solar panels in the array, the area of the outlets may be chosen proportional to the distance between the air inlet and the respective air outlet, to allow an even air flow along each solar panel. Generally, the airflow follows a path that causes the least  
15 resistance, which may lead to the undesired situation that relatively more air flows along solar panels close to the air inlet than along solar panels further from the air inlet.

To avoid a too high pressure, the solar panel system according to the invention comprises an over pressure valve, which may be integrated in an air outlet between adjacent solar panels.

In a further embodiment, the solar panel system may comprise or in particular may house an  
20 air conditioning system, arranged in the shadow of the array of solar panels. Herewith the shadow provided by the solar panels is taken advantage of. An exhaust for draining heat from the air conditioning system is preferably arranged such that it does not discharge hot air in the air stream to cool the solar panels.

In yet another embodiment, the solar panel system comprises a spherical spoiler below each  
25 panel to increase the air flow. These spherical spoilers may preferably be placed beneath the centre of the solar panels, where the temperature of the panels becomes the highest, in order to guide as much wind flux along the panels for cooling them. The system may also comprise a smog filter, which may be an electric smog filter comprising at least one cathode and anode, configured to remove particles in the air flow by means of magnetic attraction. Such electric  
30 smog filter may be placed after a generator that may form part of any embodiment of the present invention. An urban or any other wind flow interacting with the hosting structure is redirected between the solar array and bottom surface where it is led through, possibly first a

generator, a cathode anode smog filter array after which it release cleaner air into the environment.

Another aspect of the invention is that part of the device, in particular the support structure, louvers, deflectors and/or spoilers may be designed such that they have sound absorbing or limiting features. This may be obtained by a surface treatment, a structure or pattern by design  
5 or an additional sound dampening or absorbing layer, applied onto part of the device.

The supporting device may comprise spacers and a support structure for the solar panels insofar as they are not self-supporting. The plane may extend substantially parallel to the support, and the solar panels may each lie at an angle to the plane or in any case to the  
10 horizontal in order to make an optimal angle with respect to the sun, and can be placed in orientation are movable, in particular rotatable or pivotable. An alternative is that the surface or parts thereof are located at an angle with respect to the support and/or horizontally.

The maintenance device may be suspended from the mover by means of a suspension that is adjustable in height, such as a hoisting device or a winch. It may be provided with a power  
15 supply, both for movement of the mover and for height displacement of the maintenance device. Optionally there may also be a guide for cleaning fluids, other cleaning products, such as soap or foam, or a fire detergent medium. There may even be an additional mover for a dispensing device such as a nozzle for supplying such cleaning or fire detergent to the support, in most cases a building.

20 The air duct may thus comprise air guides for guiding the air along the underside of the solar panels and may in particular be provided with openings between the solar panels for discharging air.

The air duct may thus comprise at least one turbine, which is in particular rotatable about a vertical axis, wherein the air duct forms a guide for air through the turbine.

25 The displacement system may be configured for displacing the mover along a contour of the support. Normally, multiple, if not all sides of a building need to be reachable, so the displacement system may have a track that leads along the full contour of the support.

The maintenance device, in particular the gondola, may be suspended from at least one wire or winch, and extend further from its suspension point on a side facing the support than on the  
30 side remote from the support. This is to ensure that the building can be approached sufficiently close to allow workers to work safely. It may further be provided with a

counterweight, which is arranged at the side of its suspension point remote from the support at an adjustable distance thereof, to keep it hanging straight, especially with its floor surface in a horizontal neutral position.

5

The mover displacement device may comprise one (mono)rail or several rails extending along a track extending at least partly along that part of the plane projecting beyond the support along which the mover is movable.

Such track may extend at least partially above the support for providing a parking position  
10 above the support. This allows workers to enter and exit the maintenance device at a safe place, i.e. above a building rooftop.

The displacement device may also comprise an electrical contact, in particular also formed by rails, for delivering power for the movement, control and / or lifting of the device.

The rails may comprise only curves having a greater radius than a smallest radius of an outer  
15 edge of the surface, and more particularly wherein the rails follow a curve directed away from the support before following a corner of the surface, on order to allow smooth movement of the maintenance device.

The device according to the invention may also comprise a transmitter for telephone or data traffic is included in the support device, in particular in an upright thereof, and more in  
20 particular in an upright positioned on the contour of the base, more specifically a 5G transmitter. This feature may also be applied without some, more or all of the other features.

The invention is now elucidated into more detail with reference to the following figures.  
Herein:

- Figure 1 shows a first cut-away view of a device according to the invention;
- 25 - Figure 2 shows a cross section of a device according to the invention;
- Figure 3 shows a maintenance device forming part of the invention;
- Figure 4 shows a second cut-away view of a device according to the invention;
- Figure 5 shows a first detail from figure 1; and
- Figure 6 shows a second detail from figure 1.

- Figure 1 shows a cut-away view of a device 1 for generating renewable energy according to the present invention, comprising a carrying structure 2 for positioning a surface 3 with solar panels (not depicted, see cited prior art references from the same applicant) at a distance D from a support 4, in particular the roof of a building, an air duct 5, defined in height direction by the support 2 and the surface 3 wherein the surface area protrudes at least partially and preferably completely beyond the support area and wherein the carrying structure comprises a displacement system 6 for a mover 7 for a maintenance device (8, see figure 3) formed by a gondola, which displacement system 6 is designed for displacing the mover 7 at least partly along that part of the surface 3 that projects (a distance P) outside the support 4, see figure 2.
- Figure 2 shows a side view of the device 1 from figure 1. The view especially shows how a part of the surface 3 projects (a distance P) outside the support 4. Also visible in this figure is how the displacement device is integrated in the downwardly facing side of the surface 3 for carrying solar panels (not depicted). The maintenance device (8, see figure 3) is suspended from the mover 7 by means of a suspension 9 that is adjustable in height, formed by a winch 10.
- Figure 3 shows the maintenance device 8, formed by a such as the gondola, suspended from a winch 10 by cables 9, which extends further A from its suspension points 11 on a side facing the support than B on the side remote from the support. The gondola 8 is provided with a counterweight 12, which is arranged at the side of its suspension point 11 remote from the support at an adjustable distance thereof.
- Figure 4 shows that the mover 7 displacement device 6 comprises one monorail 6 extending along a track 6 extending at least partly along that part of the plane projecting P beyond the support 2. The track 6 extends in this embodiment at least partially above the support 2 for providing a parking position 13 above the support 2.
- Figure 5 shows a detail wherein the displacement device 6 also comprises an electrical contact 14 also formed by rails 14.
- Figure 6 shows a detail wherein the rails 6 comprise only curves having a greater radius R than a smallest radius r of an outer edge of the surface 3. The rails 6 follow a curve directed away 15, 16 from the support before following a corner of the surface 3.
- The above embodiments are examples only and do in no way limit the scope of the invention, as defined by the following claims.

**Claims**

1. Device for generating renewable energy, comprising:

- A carrying structure for positioning a surface with solar panels at a distance from a support, in particular the roof of a building;

5 - An air duct, defined in height direction by the support and the surface;

wherein

the surface area protrudes at least partially and preferably completely beyond the support area;

**characterised in that:**

10 - the carrying structure comprises a displacement system for a mover for a maintenance device, such as a gondola, which displacement system is designed for displacing the mover at least partly along that part of the surface that projects outside the support.

2. Device according to claim 1, wherein the maintenance device is suspended from the mover by means of a suspension that is adjustable in height, such as a hoisting device or a winch.

15 3. Device according to any of the preceding claims, wherein the air duct comprises air guides for guiding the air along the underside of the solar panels and wherein it is in particular provided with openings between the solar panels for discharging air.

4. Device according to any of the preceding claims, wherein the air duct comprises at least one turbine, which is in particular rotatable about a vertical axis, wherein the air duct forms a guide for air through the turbine.

20 5. Device according to any of the preceding claims, wherein the displacement system is configured for displacing the carrier about a contour of the support.

6. Device according to any of the preceding claims, wherein the maintenance device, such as the gondola, is suspended from a wire or winch, and extends further from its suspension point on a side facing the support than on the side remote from the support.

25 7. Device according to claim 6, wherein the maintenance device, such as the gondola, is provided with a counterweight, which is arranged at the side of its suspension point remote from the support, preferably at an adjustable distance thereof.

8. Device according to any of the preceding claims, wherein the mover displacement device comprises one monorail or several rails extending along a track extending at least partly along that part of the plane projecting beyond the support along which the mover is movable.
9. Device according to claim 8, wherein the track extends at least partially above the support  
5 for providing a parking position above the support.
10. Device according to claim 8 or 9, wherein the displacement device also comprises an electrical contact, in particular also formed by rails.
11. Device according to any of claims 8-10, wherein the rails comprise only curves having a greater radius than a smallest radius of an outer edge of the surface, and more particularly  
10 wherein the rails follow a curve directed away from the support before following a corner of the surface.
12. Device according to any of the preceding claims, wherein a transmitter for telephone or data traffic is included in the support device, in particular in an upright thereof, and more in particular in an upright positioned on the contour of the base. more specifically a 5G  
15 transmitter.
13. Device according to any of the preceding claims, wherein part of the device, in particular the support structure, louvers, deflectors and/or spoilers are sound absorbing or limiting, in particular by a surface treatment, a structure or pattern by design or an additional sound dampening or absorbing layer, applied onto part of the device.
- 20 14. Device according to any of the preceding claims, comprising a dispensing system for fluids such as water, cleaning products, such as soap or foam, or a fire detergent medium, more in particular comprising an additional mover for a dispensing device such as a nozzle for supplying such cleaning or fire detergent to the support.
15. Building, provided with a device according to any of the foregoing claims.

25

Fig. 1

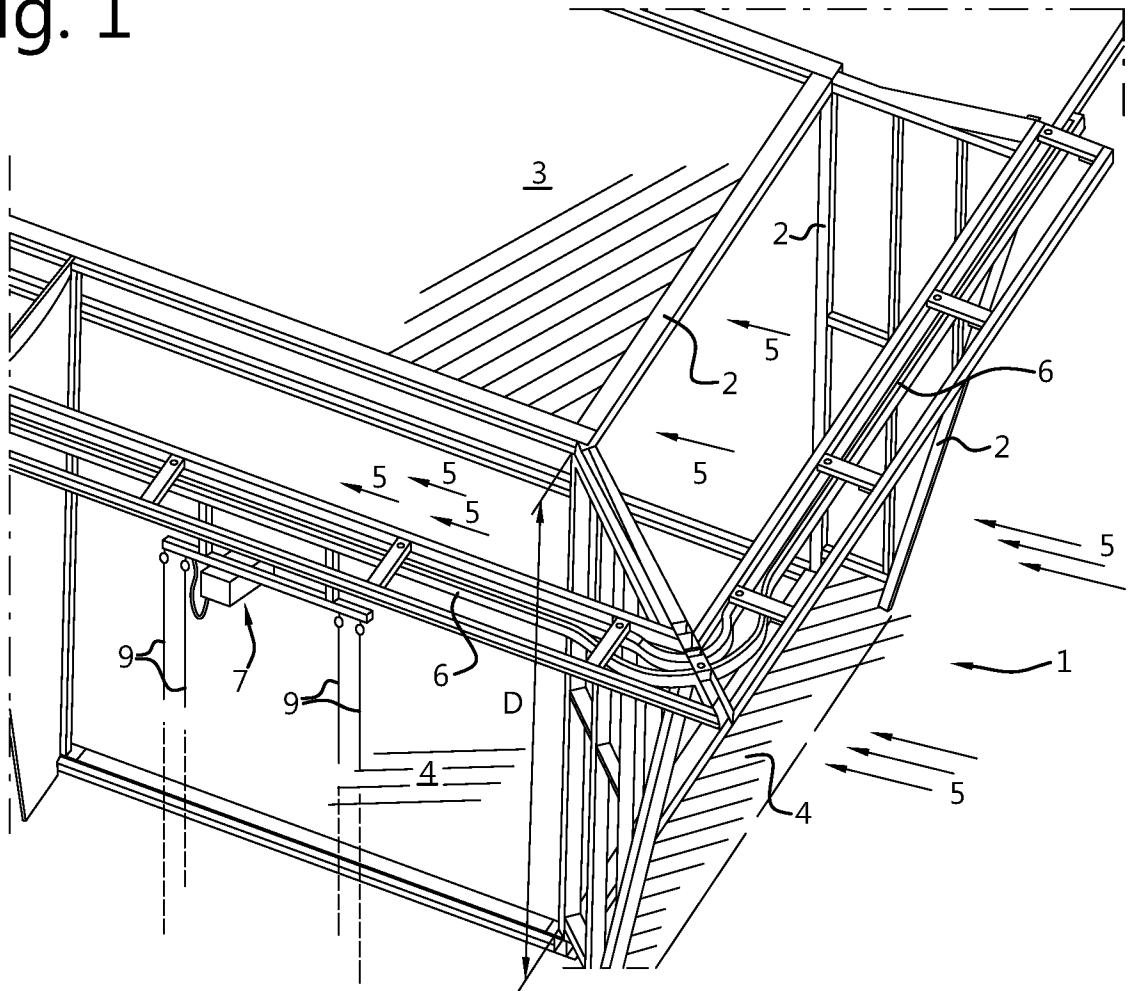

Fig. 2

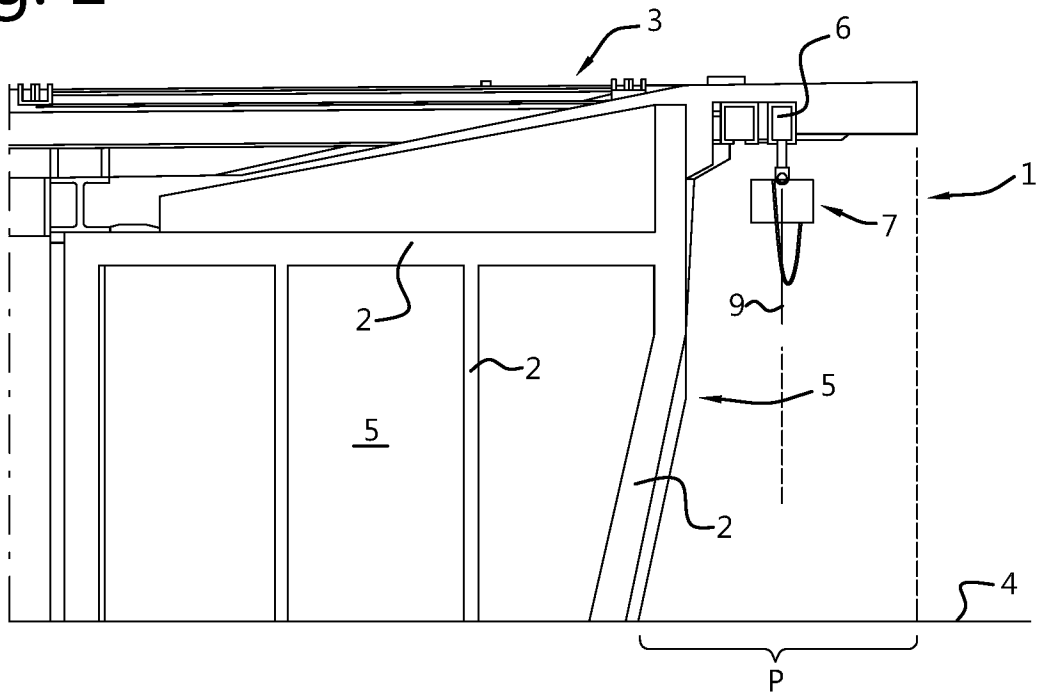

Fig. 3

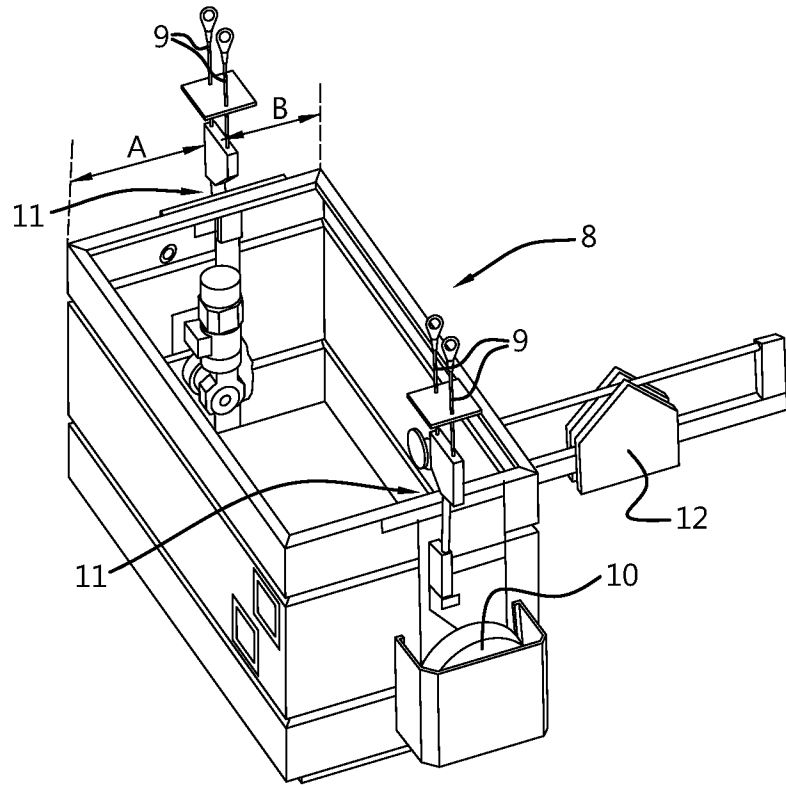

Fig. 4

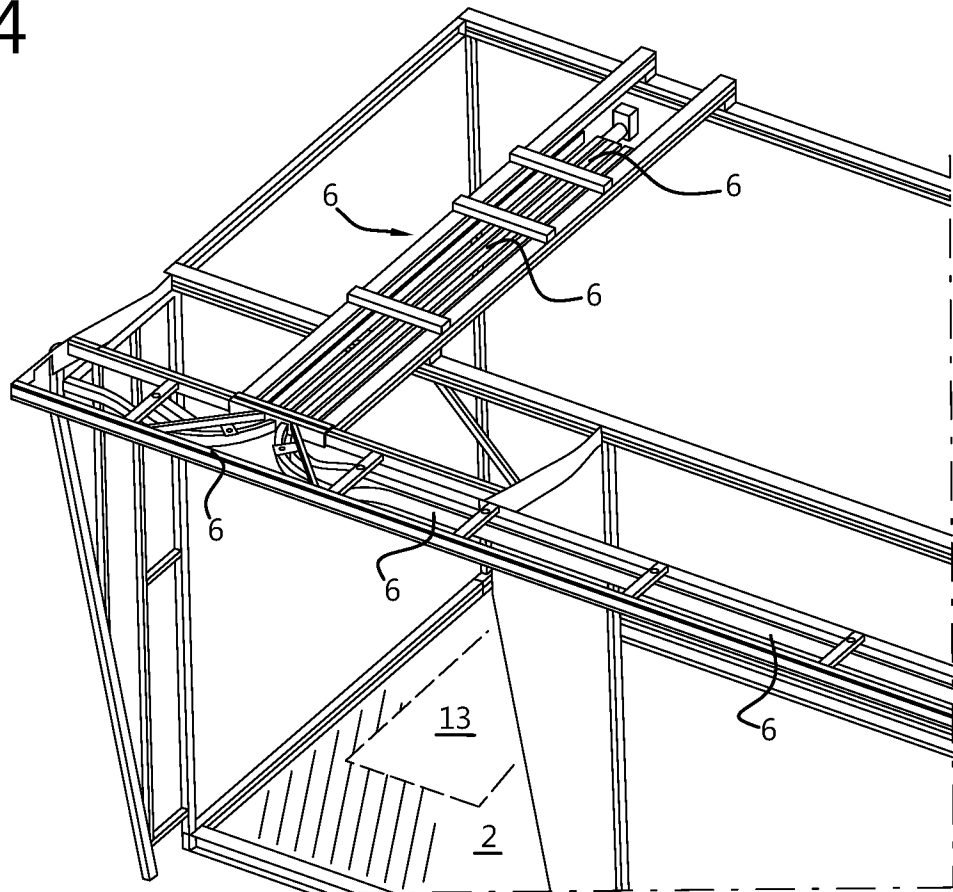

Fig. 5

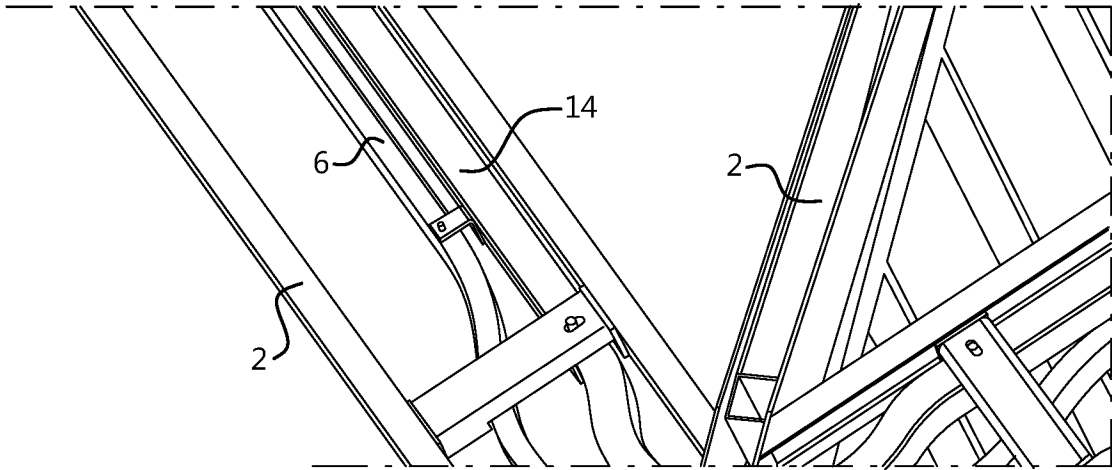
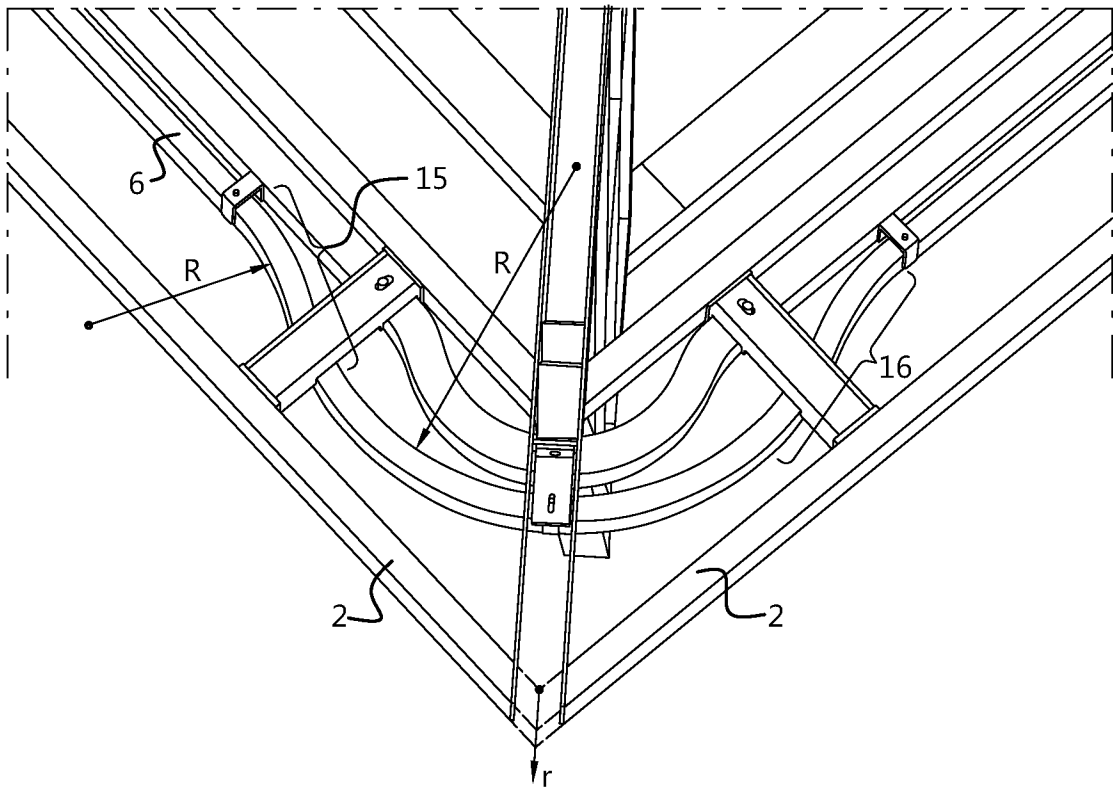

Fig. 6



## INTERNATIONAL SEARCH REPORT

International application No.  
PCT/NL2022/050 528

Box No. IV Text of the abstract (Continuation of item 5 of the first sheet)

Device for generating renewable energy, comprising a carrying structure (2) for positioning a surface (3) with solar panels at a distance (D) from a support (4), in particular the roof of a building, an air duct (5), defined in height direction by the support and the surface, wherein the surface area protrudes at least partially and preferably completely beyond the support area, wherein the carrying structure comprises a displacement system (6) for a mover (7) for a maintenance device (8), such as a gondola, which displacement system is designed for displacing the mover at least partly along that part of the surface that projects outside the support.

**INTERNATIONAL SEARCH REPORT**

International application No  
**PCT/NL2022/050528**

**A. CLASSIFICATION OF SUBJECT MATTER**  
**INV. H02S10/12 F03D3/04 H02S20/24 H02S40/10 H02S40/42**  
**ADD.**

According to International Patent Classification (IPC) or to both national classification and IPC

**B. FIELDS SEARCHED**  
 Minimum documentation searched (classification system followed by classification symbols)  
**H02S F03D**

Documentation searched other than minimum documentation to the extent that such documents are included in the fields searched

Electronic data base consulted during the international search (name of data base and, where practicable, search terms used)  
**EPO-Internal, WPI Data**

**C. DOCUMENTS CONSIDERED TO BE RELEVANT**

Category*	Citation of document, with indication, where appropriate, of the relevant passages	Relevant to claim No.
<b>A</b>	<b>WO 2020/027659 A1 (IBIS POWER HOLDING B V [NL]) 6 February 2020 (2020-02-06) page 1, line 33 - page 2, line 30 page 5, line 24 - page 6, line 10; figure 1</b>	<b>1-15</b>
<b>A</b>	<b>US 10 280 900 B1 (KRIPPENE BRETT C [US]) 7 May 2019 (2019-05-07) column 46, line 60 - column 47, line 35; figure 61</b>	<b>1-15</b>
<b>A</b>	<b>CN 108 612 183 A (ZHEJIANG WANCHUAN DECORATION DESIGN ENG CO LTD) 2 October 2018 (2018-10-02) abstract; figure 1</b>	<b>1-15</b>
	----- -/--	

Further documents are listed in the continuation of Box C.       See patent family annex.

\* Special categories of cited documents :

"A" document defining the general state of the art which is not considered to be of particular relevance	"T" later document published after the international filing date or priority date and not in conflict with the application but cited to understand the principle or theory underlying the invention
"E" earlier application or patent but published on or after the international filing date	"X" document of particular relevance; the claimed invention cannot be considered novel or cannot be considered to involve an inventive step when the document is taken alone
"L" document which may throw doubts on priority claim(s) or which is cited to establish the publication date of another citation or other special reason (as specified)	"Y" document of particular relevance; the claimed invention cannot be considered to involve an inventive step when the document is combined with one or more other such documents, such combination being obvious to a person skilled in the art
"O" document referring to an oral disclosure, use, exhibition or other means	"&" document member of the same patent family
"P" document published prior to the international filing date but later than the priority date claimed	

Date of the actual completion of the international search <b>10 November 2022</b>	Date of mailing of the international search report <b>22/11/2022</b>
--	---

Name and mailing address of the ISA/ European Patent Office, P.B. 5818 Patentlaan 2 NL - 2280 HV Rijswijk Tel. (+31-70) 340-2040, Fax: (+31-70) 340-3016	Authorized officer <b>Hofmann, Kerrin</b>
--	--

## INTERNATIONAL SEARCH REPORT

International application No  
PCT/NL2022/050528

C(Continuation). DOCUMENTS CONSIDERED TO BE RELEVANT		
Category*	Citation of document, with indication, where appropriate, of the relevant passages	Relevant to claim No.
A	<p>WO 2020/250261 A1 (VENUSIO TAMBURRINO LUIGI GIUSEPPE MARIA [IT]) 17 December 2020 (2020-12-17) abstract automatic translation relating to fig. E-G; figures E-G</p> <p style="text-align: center;">-----</p>	1-15
A	<p>CN 110 761 546 A (WUHAN RES INSTITUTE OF METALLURGICAL CONSTRUCTION MCC) 7 February 2020 (2020-02-07) abstract; figures 1,2</p> <p style="text-align: center;">-----</p>	1-15
A	<p>CN 210 433 392 U (UNIV HUNAN SCIENCE &amp; TECHNOLOGY) 1 May 2020 (2020-05-01) abstract; figures 1-15</p> <p style="text-align: center;">-----</p>	1-15
A	<p>WO 2016/015450 A1 (WEN JIAN [CN]) 4 February 2016 (2016-02-04) abstract; figures 1-3</p> <p style="text-align: center;">-----</p>	1-15

# INTERNATIONAL SEARCH REPORT

Information on patent family members

International application No

**PCT/NL2022/050528**

Patent document cited in search report	Publication date	Patent family member(s)	Publication date	
<b>WO 2020027659</b>	<b>A1</b>	<b>06-02-2020</b>	<b>AU 2019316515 A1</b>	<b>18-02-2021</b>
			<b>CA 3106964 A1</b>	<b>06-02-2020</b>
			<b>CN 112673566 A</b>	<b>16-04-2021</b>
			<b>EP 3830950 A1</b>	<b>09-06-2021</b>
			<b>KR 20210035863 A</b>	<b>01-04-2021</b>
			<b>US 2021273606 A1</b>	<b>02-09-2021</b>
			<b>WO 2020027659 A1</b>	<b>06-02-2020</b>
-----				
<b>US 10280900</b>	<b>B1</b>	<b>07-05-2019</b>	<b>NONE</b>	
-----				
<b>CN 108612183</b>	<b>A</b>	<b>02-10-2018</b>	<b>NONE</b>	
-----				
<b>WO 2020250261</b>	<b>A1</b>	<b>17-12-2020</b>	<b>BR 112021025052 A2</b>	<b>01-02-2022</b>
			<b>CL 2021003214 A1</b>	<b>07-10-2022</b>
			<b>CN 114222496 A</b>	<b>22-03-2022</b>
			<b>CO 2021016559 A2</b>	<b>17-01-2022</b>
			<b>EP 3982713 A1</b>	<b>20-04-2022</b>
			<b>US 2022217920 A1</b>	<b>14-07-2022</b>
			<b>WO 2020250261 A1</b>	<b>17-12-2020</b>
-----				
<b>CN 110761546</b>	<b>A</b>	<b>07-02-2020</b>	<b>NONE</b>	
-----				
<b>CN 210433392</b>	<b>U</b>	<b>01-05-2020</b>	<b>NONE</b>	
-----				
<b>WO 2016015450</b>	<b>A1</b>	<b>04-02-2016</b>	<b>CN 104140027 A</b>	<b>12-11-2014</b>
			<b>CN 107128853 A</b>	<b>05-09-2017</b>
			<b>WO 2016015450 A1</b>	<b>04-02-2016</b>
-----				