



Europäisches Patentamt
European Patent Office
Office européen des brevets



(11) **EP 0 831 548 A3**

(12) **EUROPEAN PATENT APPLICATION**

(88) Date of publication A3:
01.04.1998 Bulletin 1998/14

(51) Int. Cl.⁶: **H01Q 9/04**

(43) Date of publication A2:
25.03.1998 Bulletin 1998/13

(21) Application number: **97116385.2**

(22) Date of filing: **19.09.1997**

(84) Designated Contracting States:
**AT BE CH DE DK ES FI FR GB GR IE IT LI LU MC
NL PT SE**

(30) Priority: **24.09.1996 JP 251555/96**

(71) Applicant:
**MURATA MANUFACTURING CO., LTD.
Nagaokakyo-shi Kyoto-fu 226 (JP)**

(72) Inventors:
• **Itoh, Shigekazu**
Nagaokakyo-shi, Kyoto-fu (JP)
• **Suzuki, Nobuhiko**
Nagaokakyo-shi, Kyoto-fu (JP)

(74) Representative:
Schoppe, Fritz, Dipl.-Ing.
Schoppe & Zimmermann
Patentanwälte
Postfach 71 08 67
81458 München (DE)

(54) **Antenna**

(57) A strip-line-type antenna (1) is formed of dielectric layers (11a, 11b, 11c) made of a ceramic sheet, a grounding electrode layer (12) which is disposed on the upper layer of the dielectric layer (11a) and which has nearly the same area of the dielectric layer (11a), a first radiation electrode layer (13) in the shape of nearly a square which is disposed on the upper layer of the dielectric layer (11b), a second radiation electrode layer (14) which is disposed on the upper layer of the dielectric layer (11c) and which is disposed in the shape of nearly the letter L at a position corresponding to the portion where the first radiation electrode layer (13) is not disposed, a through hole (15) for feeding formed from the rear surface of the dielectric layer (11a) to the first radiation electrode layer (13) in order to feed to the first radiation electrode layer, a plurality of through holes (16) for connecting the second radiation electrode layer to the grounding electrode layer, and capacitive coupling sections (17a, 17b) which are protrusively formed in each of the first radiation electrode layer (13) and the second radiation electrode layer (14) in order to capacitively couple the first radiation electrode layer (13) to the second radiation electrode layer (14).

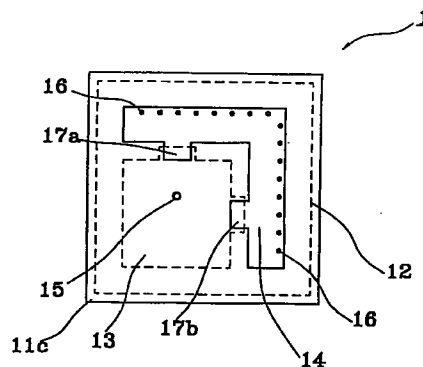

FIG. 1

EP 0 831 548 A3



European Patent
Office

EUROPEAN SEARCH REPORT

Application Number
EP 97 11 6385

DOCUMENTS CONSIDERED TO BE RELEVANT			
Category	Citation of document with indication, where appropriate, of relevant passages	Relevant to claim	CLASSIFICATION OF THE APPLICATION (Int.Cl.6)
Y	YOSHIO EBINE ET AL: "A WIDE BEAMWIDTH AND BROAD BANDWIDTH MICROSTRIP ANTENNA WITH A PAIR OF SHORT CIRCUIT PATCHES" IEICE TRANSACTIONS, vol. E74, no. 10, 1 October 1991, pages 3241-3245, XP000279305 * the whole document *	1,3,4	H01Q9/04
Y	LEGAY H ET AL: "NEW STACKED MICROSTRIP ANTENNA WITH LARGE BANDWIDTH AND HIGH GAIN" IEE PROCEEDINGS: MICROWAVES, ANTENNAS AND PROPAGATION, vol. 141, no. 3, PART H, 1 June 1994, pages 199-204, XP000459826 * the whole document *	1,3,4	
A	US 5 243 353 A (NAKAHARA ET AL.) * abstract; figures 1,7-12 *	1,7,8	
A	EP 0 655 797 A (MOTOROLA) * column 4, line 23 - line 42; figures 5,6 *	1,6	
			TECHNICAL FIELDS SEARCHED (Int.Cl.6)
			H01Q
The present search report has been drawn up for all claims			
Place of search		Date of completion of the search	Examiner
THE HAGUE		11 February 1998	Angrabeit, F
CATEGORY OF CITED DOCUMENTS			
X : particularly relevant if taken alone		T : theory or principle underlying the invention	
Y : particularly relevant if combined with another document of the same category		E : earlier patent document, but published on, or after the filing date	
A : technological background		D : document cited in the application	
O : non-written disclosure		L : document cited for other reasons	
P : intermediate document		
		& : member of the same patent family, corresponding document	

EPO FORM 1503 03.82 (P04C01)