



- (51) International Patent Classification:
A61C 8/00 (2006.01)
- (21) International Application Number:
PCT/US2012/044308
- (22) International Filing Date:
27 June 2012 (27.06.2012)
- (25) Filing Language: English
- (26) Publication Language: English
- (30) Priority Data:
61/502,091 28 June 2011 (28.06.2011) US
- (71) Applicant (for all designated States except US): **BIOMET 3I, LLC** [US/US]; 4555 Riverside Drive, Palm Beach Gardens, Florida 33410 (US).
- (72) Inventors; and
- (75) Inventors/Applicants (for US only): **BELLANCA, John, J.** [US/US]; 10432 Orchid Reserve Drive, West Palm Beach, Florida 33412 (US). **ROGERS, Dan, P.** [US/US]; 430 Oyster Road, North Palm Beach, Florida 33408 (US).

HERRINGTON, Stephen, M. [US/US]; 5935 Barclay Lane, Naples, Florida 34110 (US). **TOWSE, Ross, W.** [US/US]; 4435 SW LaPaloma Drive, Palm City, Florida 34990 (US). **GOODMAN, Ralph, E.** [US/US]; 4966 Summit Boulevard, West Palm Beach, Florida 33415 (US). **SUTTIN, Zachary, B.** [US/US]; 10436 Orchid Reserve Drive, West Palm Beach, Florida 33412 (US). **SCALISE, Isabel** [US/US]; 308 Sunset Road, West Palm Beach, Florida 33401 (US). **BOBBY, Michael** [US/US]; 139 Harbors Way, Boynton Beach, Florida 33435-2400 (US).

(74) Agents: **BURNHAM, Daniel, J.** et al.; Nixon Peabody LLP, 300 S. Riverside Plaza, 16th floor, Chicago, Illinois 60606 (US).

(81) Designated States (unless otherwise indicated, for every kind of national protection available): AE, AG, AL, AM, AO, AT, AU, AZ, BA, BB, BG, BH, BR, BW, BY, BZ, CA, CH, CL, CN, CO, CR, CU, CZ, DE, DK, DM, DO, DZ, EC, EE, EG, ES, FI, GB, GD, GE, GH, GM, GT, HN, HR, HU, ID, IL, IN, IS, JP, KE, KG, KM, KN, KP, KR, KZ, LA, LC, LK, LR, LS, LT, LU, LY, MA, MD, ME, MG, MK, MN, MW, MX, MY, MZ, NA, NG, NI, NO, NZ,

[Continued on next page]

(54) Title: SYSTEM AND METHOD OF DENTAL IMPLANT AND INTERFACE TO ABUTMENT FOR RESTORATION

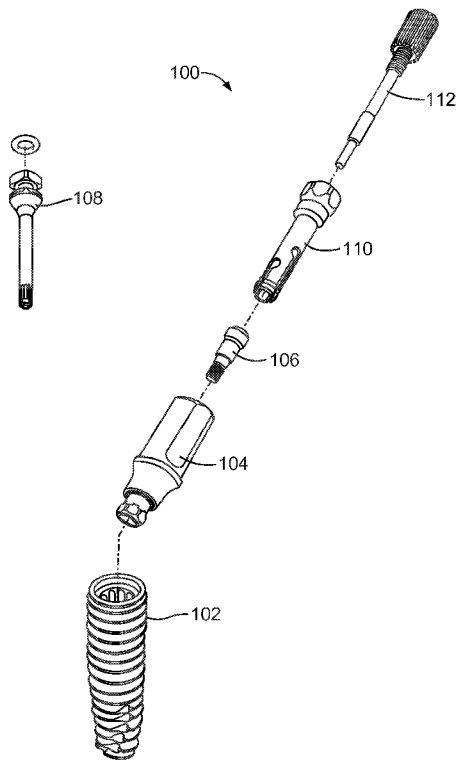

FIG. 1

(57) Abstract: A dental assembly for vertical attachment of an implant to a dental abutment for restorative dental procedures is disclosed. The implant includes a cylindrical body having an interior bore formed between a distal end and a proximal end. An abutment interface is formed on the proximal end of the cylindrical body. The interface includes a radial annular interior surface and a flat annular stop surface circumferentially bordering the interior bore. The assembly also includes an abutment including a stem and a post coupled to the stem. An interior bore is formed through the stem and the post. The abutment includes an interface section between the post and the stem. The interface section may include an annular radially curved exterior surface proximate to the post. The radially curved exterior surface and the circular flat surface interfaces with the abutment interface of the dental implant.

WO 2013/003408 A1

OM, PE, PG, PH, PL, PT, QA, RO, RS, RU, RW, SC, SD, SE, SG, SK, SL, SM, ST, SV, SY, TH, TJ, TM, TN, TR, TT, TZ, UA, UG, US, UZ, VC, VN, ZA, ZM, ZW.

(84) Designated States (unless otherwise indicated, for every kind of regional protection available): ARIPO (BW, GH, GM, KE, LR, LS, MW, MZ, NA, RW, SD, SL, SZ, TZ, UG, ZM, ZW), Eurasian (AM, AZ, BY, KG, KZ, RU, TJ, TM), European (AL, AT, BE, BG, CH, CY, CZ, DE, DK, EE, ES, FI, FR, GB, GR, HR, HU, IE, IS, IT, LT, LU, LV, MC, MK, MT, NL, NO, PL, PT, RO, RS, SE, SI, SK, SM, TR), OAPI (BF, BJ, CF, CG, CI, CM, GA, GN, GQ, GW, ML, MR, NE, SN, TD, TG).

Declarations under Rule 4.17:

- as to applicant's entitlement to apply for and be granted a patent (Rule 4.17(ii))
- as to the applicant's entitlement to claim the priority of the earlier application (Rule 4.17(iii))

Published:

- with international search report (Art. 21(3))

SYSTEM AND METHOD OF DENTAL IMPLANT AND INTERFACE TO ABUTMENT FOR RESTORATION

PRIORITY CLAIM AND CROSS REFERENCE TO RELATED APPLICATIONS

[0001] This application claims priority to U.S. Provisional Application No. 61/502,091, filed on June 28, 2011 which is incorporated herein its entirety.

TECHNICAL FIELD

[0001] This disclosure relates to restorative dental implants and abutments and related tools for the assembly and disassembly of the same.

BACKGROUND

[0002] Single tooth restorations present the unique requirement that they must be supported non-rotationally on an underlying abutment. When a prepared natural tooth is the underlying abutment, this requirement is met in the normal course of preparing the abutment with a non-circular cross-section. Likewise, when the underlying abutment is a post fitted onto an implant, this requirement is met by preparing the post with a noncircular cross-section. This latter scenario can be more complicated due to the added connection between the implant and the abutment.

[0003] Typically, a dental implant is implanted into the bone of a patient's jaw and comprises a socket, e.g., a bore, which is accessible through the overlying or surrounding gum tissue for receiving and supporting one or more attachments or components which, in turn, are useful to fabricate and support the prosthodontic restoration. Dental implant procedures may use a variety of implanting modalities, for example, blade, threaded implant, or smooth push-in implant.

[0004] While numerous design iterations have been marketed, overall there have been three generations of the implant-abutment interface within these assemblies: an external hex implant, an internal connection implant, and a vertical connection assembly. The external hexagonal implant design has a hexagonal shape (or another anti-rotation feature) protruding out of the implant and the corresponding abutment has a female hexagonal receptacle. There is a surface below the hexagonal protrusion on which the abutment is seated. The hexagonal protrusion acts to constrain the abutment from rotating around the longitudinal axis as well as preventing movement on the plane coincident with the implant seating surface.

Unfortunately, such an interface has virtually no stability until the screw is introduced and fully seated between the abutment and the implant. The screw is essentially the sole component resisting bending forces.

[0005] In contrast, the internal connection implant design has a hexagonal female member (or other anti-rotation feature) extruded into the implant, and the corresponding abutment has a male hexagonal protrusion. The abutment is seated on the same surface as the external hexagonal design, the only difference being that the anti-rotation feature on the implant is located below this surface. The benefit of this system is that it has intrinsic stability without the screw, and then experiences increased stability once the screw is introduced and fully seated. The system responds in a more unified manner to bending forces. While this system has advantages over the external hex implant, the disadvantage (which applies to the external hex as well) is that it is prone to leak at the implant-abutment interface (seating surface) due to “lifting” of the abutment under load that may create an intermittent gap resulting in bacteria penetration and subsequent crestal bone loss.

[0006] Another alternative interface is an internal/vertical connection implant assembly where the abutment sits “vertically” within the implant assembly and is supported by the internal sidewalls. In addition to this vertically interfacing aspect, many abutments contain a male anti-rotation feature at the bottom and the corresponding implants have a female receptacle (similar to the internal connection implant design). The main benefits of this design are that the two components effectively wedge together, creating a seal impenetrable to bacteria and the abutment receives added lateral support from the implant due to interaction of the abutment sidewalls with the interior surfaces of the implant. However, such designs suffer from vertical location variability. The accuracy of the fit of the final implant restoration (i.e., crown) is largely dependent on the ability to reliably transfer the location of the implant throughout the multiple steps involved in fabricating the restoration. The currently marketed vertical connection implant systems are susceptible to significant vertical location variability, and subsequent customer dissatisfaction. Location variability is undetectable until the very last step in the restorative process when the patient receives their restoration where it becomes apparent the restoration is too high or too low relative to the original tooth. For example, due to the required manufacturing tolerances, each time an abutment (or other male part) is mated with an implant (or other female part) the initial vertical position is destined to change. Further, once the parts are mated and torque is

applied to the screw attaching the abutment to the implant, there is relative motion (or vertical displacement) between the male and female components. The magnitude of this motion is dependent on multiple variables, including but not limited to the screw torque, the surface finishes, and the component specifications.

[0007] Known vertical implant systems therefore still allow the lateral movement of the abutment in relation to the implant thus causing the possibility of misalignment. It would be desirable to have an abutment implant interface that eliminates vertical location variability. As the vertical connection implant assembly becomes accepted, it is necessary to develop a system that maintains the benefits of this type of design, yet eliminates the known vertical location variability problem. It would also be desirable for a system to create seals between the abutment and implant. The increase in seals in a contemplated system may result in adhesion between the implant and the abutment. Therefore it would be desirable for a removal system to assist in the removal of an abutment that adheres to an implant due to an improved interface.

BRIEF SUMMARY

[0008] An aspect of the present disclosure is an abutment for use in conjunction with a dental implant. The abutment includes a stem and a post opposite of the stem. An interior bore is formed through the stem and the post. An interface section is formed between the post and the stem. The interface section has an annular radially curved exterior surface proximate to the post. The annular radially curved exterior surface interfaces with the dental implant.

[0009] Another disclosed aspect is a dental implant for use in conjunction with an abutment. The implant includes a cylindrical body having an interior bore formed between a distal end and a proximal end. An abutment interface is located on the proximal end of the cylindrical body. The interface includes a radial annular interior surface bordering the interior bore. An anti-rotational cavity is formed in the interior bore proximal to the interface.

[0010] Another disclosed aspect is a dental restoration system including an abutment and an implant. The implant attaches to a jaw bone of a patient. The implant includes a cylindrical body having an interior bore formed between a distal end and a proximal end. An abutment interface is located on the proximal end of the cylindrical body. The interface includes a radial annular interior surface circumferentially bordering the interior bore. An

anti-rotational cavity is formed in the interior bore proximal to the interface. The abutment includes a stem and a post opposite the stem. An interior bore is formed through the stem and the post. An interface section is located between the post and the stem. The interface section has an annular radially curved exterior surface proximate to the post. The radially curved exterior surface interfaces with the abutment interface of the dental implant.

[0011] Another aspect of the disclosure is an abutment for use in conjunction with a dental implant. The abutment includes a stem and a post opposite the stem. An interior bore is formed through the stem and the post. An interface section is located between the post and the stem. The interface section has an exterior surface proximate to the post. The exterior surface terminates into a circular flat surface. The post extends from the circular flat surface. An annular groove is cut into the circular flat surface to allow compliant fit of the interface section with a mating interface surface of the implant.

[0012] Another aspect of the present disclosure is an abutment removal tool system for removing an abutment from an implant. The abutment includes an interior bore extending therethrough having a groove and an interface in contact with a corresponding interface on the implant. An abutment removal insert has a cylindrical end insertable into a groove formed in the interior bore of the abutment. An abutment removal tool screw is insertable within the abutment removal insert. The abutment removal tool screw includes a grip end and an opposite end. The opposite end causes the abutment removal insert to contact the abutment. The grip is rotatable to cause the opposite end to create force against the implant to cause the abutment to be detached from the implant.

[0013] Another aspect of the present disclosure is an implant driver tool for imparting rotational force to a dental implant including an exterior threaded force and an interior bore having an anti-rotational cavity and a counter bore. The implant driver tool includes a shaft having a proximal end and a distal end including a driver section mateable with the anti-rotation cavity of the implant for driving the implant into bone. The implant driver tool includes an end attached to the driver section for contact with the counter bore to hold the driver tool to the implant. A grip section is coupled to the proximal end of the shaft.

[0014] The foregoing and additional aspects and implementations of the present disclosure will be apparent to those of ordinary skill in the art in view of the detailed description of various embodiments and/or aspects, which is made with reference to the drawings, a brief description of which is provided next.

BRIEF DESCRIPTION OF THE DRAWINGS

[0015] The foregoing and other advantages of the present disclosure will become apparent upon reading the following detailed description and upon reference to the drawings.

[0016] FIG. 1 is an exploded perspective view of an implant and abutment dental restoration system including an implant, an abutment, an insert screw, an implant driver, a removal tool, and a removal tool screw;

[0017] FIG. 2A is a perspective view of the dental implant with a vertical abutment interface shown in FIG. 1;

[0018] FIG. 2B is a side view of the implant shown in FIG. 2A;

[0019] FIG. 2C is a cross-section side view of the implant shown in FIG. 2A;

[0020] FIG. 2D is a view of the distal end of the implant shown in FIG. 2A;

[0021] FIG. 3A is a perspective view of the abutment with a vertical implant interface shown in FIG. 1;

[0022] FIG. 3B is a side view of the abutment shown in FIG. 3A;

[0023] FIG. 3C is a cross-section side view of the abutment shown in FIG. 3A;

[0024] FIG. 3D is a front view of the abutment shown in FIG. 3A;

[0025] FIG. 4A–B are perspective side cutaway views of the initial contact and final contact between abutment and implant in FIG. 1 when seating the abutment in the implant;

[0026] FIG. 4C-4E are side cutaway views of seating an alternate abutment in an alternate implant with a stop member for vertical location;

[0027] FIG. 5A–C are side cutaway views of the contacts between the abutment and implant in FIG. 1 in the process of seating the abutment in the implant;

[0028] FIG. 6A is a perspective view of an alternate design for the abutment with a groove in the interface to facilitate fit into an implant;

[0029] FIG. 6B is a side view of the abutment shown in FIG. 6A;

[0030] FIG. 6C is a cross-section side view of the abutment shown in FIG. 6A;

[0031] FIG. 6D is a close up perspective view of the groove on the alternate design for the abutment shown in FIG. 6A

[0032] FIG. 7A is a side view of the alternate abutment design in FIG. 6A in contact with an implant;

[0033] FIG. 7B is a stress diagram of the abutment in FIG. 6A in contact with the implant;

[0034] FIG. 8A is a perspective view of the implant driver tool shown in FIG. 1;

[0035] FIG. 8B is a side view of the implant driver tool shown in FIG. 8A;

[0036] FIG. 8C is a close up view of the implant driver tool shown in FIG. 8A showing the members of the tip;

[0037] FIG. 9A is a perspective view of the abutment removal tool screw shown in FIG. 1;

[0038] FIG. 9B is a side view of the abutment removal tool screw shown in FIG. 9A;

[0039] FIG. 9C is a front view of the abutment removal tool screw shown in FIG. 9A;

[0040] FIG. 10A is a perspective view of the abutment removal tool insert shown in FIG. 1;

[0041] FIG. 10B is a side view of the abutment removal tool insert shown in FIG. 10A;

[0042] FIG. 10C is a cross-section side view of the abutment removal tool insert shown in FIG. 10A;

[0043] FIG. 10D is a front view of the abutment removal tool insert shown in FIG. 10A;

[0044] FIG. 10E is a back view of the abutment removal tool insert shown in FIG. 1;

[0045] FIG. 11A–E are steps of the process of using the abutment removal tool implant and implant driver in FIG. 1 in separating the abutment from the insert;

[0046] FIG. 12A is a perspective view of an alternate implant driver tool with a friction fit tapered nose;

[0047] FIG. 12B is a close up view of the implant driver tool shown in FIG. 12A showing the friction fit tapered nose of the tip;

[0048] FIG. 12C is a close up view of the implant driver tool shown in FIG. 12A showing the fit taper nose with a bore;

[0049] FIG. 12D is a front view of the tip of the taper nose in FIG. 12C;

[0050] FIG. 13A is a perspective view of an alternate implant driver tool;

[0051] FIG. 13B is a side view of the implant driver tool shown in FIG. 13A;

[0052] FIG. 13C is a close up view of the implant driver tool shown in FIG. 13A showing the members of the tip; and

[0053] FIG. 13D is a front cross-section view of the tip of the implant driver tool shown in FIG. 13A from the perspective of the lines 13D-13D' in FIG. 13C.

[0054] While the invention is susceptible to various modifications and alternative forms, specific embodiments have been shown by way of example in the drawings and will be described in detail herein. It should be understood, however, that the invention is not intended to be limited to the particular forms disclosed. Rather, the invention is to cover all modifications, equivalents, and alternatives falling within the spirit and scope of the invention as defined by the appended claims.

DETAILED DESCRIPTION

[0055] FIG. 1 is an exploded perspective view of the implant and abutment installation system 100 including an implant 102, an abutment 104, an abutment screw 106, and an implant driver tool 108. FIG. 1 also shows a removal system for the abutment 104 including an abutment removal insert tool 110, and an abutment removal tool screw 112. The components shown in FIG. 1 are used in dental restorative processes. As is known, the implant 102 is implanted into the bone of a patient's jaw. The implant driver tool 108 is used to fix the implant 102 into the bone. The abutment 104 may be a standard part or customized to replace the patient's tooth and is attached to the implant 102. The abutment 104 is fixed to the implant 102 via the abutment screw 106, which may be installed via a screw driver tool. In cases where the abutment 104 must be removed from the implant 102 and cannot be readily removed by hand (after the abutment screw 106 is removed), the abutment removal insert tool 110 is used in conjunction with the removal tool screw 112 to remove the abutment 104 without displacing and or rotating the implant 102.

[0056] The implant 102 is further detailed in FIGs. 2A–2D where FIG. 2A is a perspective view of the implant 102, FIG. 2B is a side view of the implant 102, FIG. 2C is a cross-section side view of the implant 102, and FIG. 2D is a view of the distal end of the implant 102. The implant 102 comprises a proximal end 202, a distal end 204 opposite the proximal end 202 and at least one thread 206 disposed therebetween for screwing the implant 102 into the bone of a patient. The proximal end 202 includes an interface 208 adapted to guide the abutment 104 in FIG. 1 when seating the abutment 104 in the implant 102. The implant 102 also includes an interior bore 210 that extends distally from the proximal end 202 toward the distal end 204. The interior bore 210 includes a first anti-rotation cavity 214 and a second anti-rotation cavity 216 distal of the first anti-rotation cavity 214. The interface 208 is concentrically located around the interior bore 210 and is proximal to the first anti-rotation cavity 214. A counter bore 212 is formed between the two cavities 214 and 216.

[0057] As shown in detail in FIG. 2C, the two cavities 214 and 216 are separate, distinct and slightly spaced apart, and are connected with a series of concentric steps including the counter bore 212. Other arrangements, however, are equally suitable, such as, for example, where the cavities are adjacent with a tapered transition, or spaced apart and connected by one or more cavities. As will be explained below, the counter bore 212 is fabricated at a narrower diameter than the first cavity 214 to assist in fixing an implant driver tool such as the implant driver tool 108 in FIG. 1 to the implant 102.

[0058] Focusing on FIGs. 2C and 2D, the first anti-rotation cavity 214 of implant 102 includes a multi-sided socketed interior surface 220. The socketed interior surface 220 has a plurality of obtuse interior angles in a double hexagonal shape, but other socket shapes may be used. The second anti-rotation cavity 216 includes a threaded interior surface 222 that accepts the abutment screw 106 in FIG. 1.

[0059] For some applications, at least one of the anti-rotation cavities 214 and 216 is adapted to mate with a conventional driving tool, for example, a tool with a working end comprising a square, a pentagon, a hexagon, an octagon, etc. Some tools are described in detail such as the implant driver tool 108 shown in detail in FIGs. 8A–8C and the implant driver tool 1200 shown in detail in FIGs. 12A–12B. The cavities 214 or 216 may also be used to hold the abutment 104. However, the other cavity may be adapted to mate with an abutment stem having a predetermined shape other than the cavity that holds the driving tool.

[0060] The interface 208 is cylindrically shaped having an interior surface ending in a radially curved annular inner surface 230 proximate the first anti-rotation cavity 214. The annular inner surface 230 transitions to a flat circular vertical stop surface 232 that borders the first cavity 214. As will be explained below, the radially curved inner surface 230 and the vertical stop surface 232 function to guide the abutment 104 and prevent vertical location variability of the abutment 104 relative to the implant 102. The contact of the inner surface 230 and the vertical stop surface 232 of the interface 208 also form seals to prevent gaps in the interface between the implant 102 and the abutment 104.

[0061] FIG. 3A–3D are views of the abutment 104 shown in FIG. 1 where FIG. 3A is a perspective view of the abutment 104, FIG. 3B is a side view of the abutment 104, FIG. 3C is a cross-section side view of the abutment 104, and FIG. 3D is a front view of the abutment 104. The abutment 104 comprises a post 302 and a stem 304 extending in a relative downward direction from the post 302. The stem 304 includes a locking portion 306 adapted

to be positioned in the first anti-rotation cavity 214 when the abutment 104 is positioned in the implant 102. Accordingly, the locking portion 306 has a multi-sided exterior surface 308 that is adapted to rotationally-lockingly engage the interior multi-sided socketed surface 220 of the first anti-rotation cavity 214 in FIG. 2C, wherein the abutment 104 is prevented from rotating relative to the implant 102.

[0062] The abutment 104 includes a transitional section 310 between the post 302 and the stem 304. The transitional section 310 is roughly conical in shape with a larger end connected to the post 302 and an opposite smaller end connected to the stem 304. The smaller end of the transitional section 310 mates with the interface 208 of the implant 102 in FIGs. 2A–2D. The transitional section 310 includes an outer surface that has a curved shape from the larger end with the larger diameter closest to the post 302 to the opposite end with a smaller diameter connected to the stem 304. A radially shaped annular outer surface 320 terminates at the smaller end of the transitional section 310. The outer surface 320 forms a circular vertical stop surface 322 forming the bottom of the transitional section 310 from which the stem 304 protrudes. The circular vertical stop surface 322 includes a circular groove 324 that is cut into the transitional section 310. The circular groove 324 in this example is cut to a depth of approximately 0.012 inches. The circular groove 324 may be cut to a depth of 0.010 to 0.020 inches or deeper or shallower if desired.

[0063] In the abutment 104, a through-bore 326 extends through the post 302, the stem 304, and the transitional section 310 to allow the abutment screw 106 shown in FIG. 1 to be inserted therein. The abutment screw 106 is inserted into the through-bore 326 in the abutment 104 to threadably engage the threads of the interior surface 222 of the implant 102 as shown in FIG. 2C. The through-bore 326 also includes a groove 328 that is formed to roughly mate with the abutment removal insert tool 110 as will be explained below.

[0064] In FIG. 1, the abutment screw 106 includes a screw head adapted to mate with a driving tool (not shown) with a screw head such as an Allen wrench, a square driver, a flat head screwdriver, a Phillips screwdriver, etc. After the abutment 104 is placed in the implant 102, the abutment screw 106 is inserted in the through-bore 326 of the abutment 104 and the cavity 216 of the implant 102. The driving tool is used to tighten the abutment screw 106 by engaging the threaded interior surface 222 of the cavity 216. After the abutment screw 106 threadably engages the implant 102, the abutment screw 106 acts to retain the abutment 104 in the implant 102.

[0065] The combination of the radially shaped annular outer surface 320 and the vertical stop surface 322 allows for a seal between abutment 104 and the implant 102. The vertical stop surface 322 prevents vertical location variability of the abutment 104 relative to the implant 102. The insertion of the abutment 104 in the implant 102 may be shown with reference to FIGs. 4A–4B and 5A–5C. FIGs. 4A–4B are perspective side cutaway views of the initial contact and final contact between abutment 104 and implant 102 in FIG. 1 while FIG. 5A–C are side cutaway views of the contacts between the abutment 104 and implant 102 in the process of locating the abutment 104 on the implant 102. For convenience of illustration, the groove 324 has been omitted from FIGs. 4A–4B and FIG. 5C. As shown in FIG. 4A and 5A, the radially shaped outer surface 320 is inserted into the interface 208 of the implant 102 when the stem 304 is inserted in the cavity 214. The radially shaped outer surface 320 initially contacts the radially curved inner surface 230 of the interface 208. The abutment 104 is inserted into the implant 102 until the vertical stop surface 322 contacts the flat vertical stop surface 232 bordering the cavity 214 as shown in FIGs. 4B and 5B.

[0066] The radial interface 322 and the vertical stop surface 232 eliminate location variability from abutment 104 being seated in the implant 102. As may be seen in FIGs. 4 and 5, the vertical stop surface 232 of the implant 102 is connected to the radially curved inner surface 230. All the components in the restorative process requiring vertical location control use the vertical stop surface 232 for vertical location, so there is no error accumulated throughout the restorative process using the implant 102 and the abutment 104. During the restorative process involving the fabrication of the abutment 104, there is no contact with the radially curved sidewalls of the surface 320 for certain components because no seal is required. This is achieved in intermediate steps of the restorative process for these components by removing the radial interface on intermediate components such as the impression coping and the implant analog, thus ensuring that the abutment 104 contacts the vertical stop in the final assembly and prevent distortions from sidewall contact when using the intermediate components. Thus, the radially curved inner surface 230 of the implant 102 interfaces with the radially shaped outer surface 320 of the abutment 104, but the vertical position of the finish location is controlled by the radial interface 322 in contact with the vertical stop surface 232. This interface results in a first radial seal on the radially shaped outer surface 320 of the abutment 104 in contact with the radially curved inner surface 230 of the implant 102 as shown in FIG. 5C. A second horizontal seal on the bottom of the

transitional section 310 is formed via the contact of the radial interface 322 of the abutment 104 with the vertical stop surface 232 of the implant 102.

[0067] The radial interface 322 and the vertical stop surface 232 shown in FIG. 4A-4B and FIG. 5A-5C may be used with non-curved interfaces. FIG. 4C shows an implant 400 with a standard conical interface having a vertical stop surface 402 contacting an abutment 450. FIG. 4D is a close up view of the interface between the implant 400 and the abutment 450 prior to connection of the components while FIG. 4E is a close up view of the interface between the implant 400 and the abutment 450 when a seal has been established. The abutment 450 has a radial interface 452 that provides contact with the vertical stop surface 402. The vertical stop surface 402 eliminates location variability from the abutment 450 being seated in the implant 400. In this example, the abutment 450 has a standard conical interface surface 454 while the implant has a conical inner surface 404. As may be seen in FIGs. 4C and 4E, the vertical stop surface 402 of the implant 400 is connected to the conical inner surface 404. All the components in the restorative process requiring vertical location control use the vertical stop surface 402 for vertical location, so there is no error accumulated throughout the restorative process using the implant 400 and the abutment 450. During the restorative process involving the fabrication of the abutment 450, there is no contact with the conical surface 454 for certain components because no seal is required. This is achieved in intermediate steps of the restorative process for these components by removing the radial interface on intermediate components such as the impression coping and the implant analog, thus ensuring that the abutment 450 contacts the vertical stop surface 402 of the implant 400 in the final assembly and prevent distortions from sidewall contact when using the intermediate components. Thus, the conical inner surface 402 of the implant 400 interfaces with the conical surface 454 of the abutment 450, but the vertical position of the finish location is controlled by the vertical stop 402. A seal on the bottom of the transitional section of the abutment 450 is formed via the contact of the radial interface 452 of the abutment 450 with the vertical stop surface 402 of the implant 400. In this example, the angle of the conical inner surface 402 of the implant 400 is approximately 16 degrees while the angle of conical surface 454 of the abutment 450 is approximately 20 degrees. The lateral forces are concentrated at the top edge of the implant 400 on the conical inner surface 404 in order to aid in seating the abutment 450 in the implant 400. The contact between the conical inner

surface 404 and the conical interface surface 454 also create another seal in addition to the seal between the radial interface 452 against the vertical stop surface 402.

[0068] A further benefit of better compliance is realized via the groove 324 on the abutment 104 shown in detail in FIGs. 3A-3D. The groove 324 allows a more compliant interface of the abutment 104 with the implant 102. Due to the groove 324, the interface formed by the radially curved surface 320 of the transitional section 310 has built in flexibility to compress into the groove 324 to allow the radially curved surface 320 to better conform to the radially curved inner surface 230 of the implant 102 and in turn increase the seal contact area between the abutment 104 and the implant 102. This flexibility is achieved by removing material from the cross-section of transitional section 310 of the abutment 104 to form the groove 324. Further, because the abutment 104 is compliant with the implant 102, the design may be manufactured more robustly, as the system will work under a wider range of tolerance configurations.

[0069] The use of a groove such as the groove 324 shown in FIG. 3A-D in the interface of the abutment 104 may be used with conventional interfaces for vertical implant connection of abutments to any implant similar to the implant 102 in FIG. 1. For example, FIGs. 6A-6D are views of an abutment 600 having a conventional conical tapered interface but using the groove feature. FIG. 6A is a perspective view for the abutment 600 with a groove into the interface to the implant, FIG. 6B is a side view of the abutment 600 shown in FIG. 6A, FIG. 6C is a cross-section side view of the abutment 600 shown in FIG. 6A, and FIG. 6D is a close up perspective view of the groove on the alternate design for the abutment 600 shown in FIG. 6A.

[0070] The abutment 600 comprises a post 602 and a stem 604 extending in a relative downward direction from the post 602. The stem 604 includes a locking portion 606 adapted to be positioned in the first anti-rotation cavity 214 of the implant 102 when the abutment 104 is positioned in the implant 102. The locking portion 606 has a multi-sided exterior surface 608 that is adapted to rotationally-lockingly engage an interior multi-sided socketed surface such as the surface 220 of the first anti-rotation cavity 214 in FIG. 2C, wherein the abutment 600 is prevented from rotating relative to the implant.

[0071] The abutment 600 includes a transitional section 610 between the post 602 and the stem 604. The transitional section 610 mates with an exterior surface of the implant. The transitional section 610 includes an outer surface that generally slopes from a greater

diameter closest to the post 602 to a smaller diameter close to the stem 604. A conically shaped outer surface 620 terminates into a circular vertical stop surface 622. The circular vertical stop surface 622 includes a circular groove 624. The circular groove 624 permits built in flexibility to allow the abutment 600 to better conform to the corresponding shaped inner surface of the implant and in turn increase the seal contact area between the abutment 600 and the implant.

[0072] FIG. 7A is a side view of the abutment 600 in FIG. 6A in contact with an implant 700 and FIG. 7B is a stress diagram of the abutment 600 in contact with the implant 700. In this example, the implant 700 is similar to the implant 102, except that the implant 700 has a conventional conical interface surface 702. As may be seen in FIGs. 7A and 7B, a further benefit of better compliance is realized via the groove 624 on the abutment 600 which has a conventional conical interface surface 610. The inset portion of FIG. 7A is an extreme close up of the groove 624 cut into the transitional section 610. The groove 624 allows a more compliant interface of the abutment 600 with the implant 700. Due to the groove 624, the interface formed by the conically shaped outer surface 620 of the transitional section 610 has built in flexibility to compress into the groove 624 to allow the conically shaped outer surface 620 to better conform to the conically sloped interface inner surface 702 of the implant 700 and in turn increase the seal contact area between the abutment 600 and the implant 700. This flexibility is achieved by removing material from the cross-section of transitional section 610 of the abutment 600 to form the groove 624. Further, because the abutment is compliant with the implant 700, the design may be manufactured more robustly, as the system will work under a wider range of tolerance configurations. FIG. 7B shows compressive areas of stress 710 which are compressed from the conical sidewall 702 of the implant 700 pushing into the conically shaped outer surface 620 of the abutment 600.

[0073] FIG. 8A is a perspective view of the implant driver tool 108 shown in FIG. 1 and FIG. 8B is a side view of the implant driver tool 108. The implant driver tool 108 is adapted to mate with the first anti-rotation cavity 214 of the implant 102. When the implant driver tool 108 is mated with the implant 102, the driver tool 108 may be rotated to drive the threaded exterior surface 206 of the implant 102 into the bone. The implant driver tool 108 includes a first end 800 and a working end 802 that is adapted to fit within the bore 210 of the implant 102 in FIG. 2C. The first end 800 is a grip section that includes a wrench interface 804 that is spaced from a conical transition section 806 to form an annular groove 808. A

resilient ring, such as an O-ring 810, is seated in the annular groove 808 to help retain the implant driver tool 108 in proper engagement with a torque wrench. The implant driver tool 108 has a shaft 812 having a proximal end coupled to the grip section of the first end 800 and a distal end that forms the working end 802. The distal end of the shaft 812 includes a hexagonal male geometry driver section 820 adapted to mate with the socketed interior surface 220 of the anti-rotation cavity 214 of the implant 102. The contact between the driver section 820 and the socketed interior surface 220 of the implant 102 allows the transition of torque force from the driver tool 108 to the implant 102.

[0074] The wrench interface 804 of the implant driver tool 108 in this example has a four sided exterior surface to interface with a torque wrench that may be used to provide torque to turn the implant driver tool 108 and thereby the implant 102 to engage the threads on the exterior surface 206 with the bone to seat the implant 102. In order to maintain sterile conditions, the implant 102 is generally packed in a sterile package. The driver section 820 includes an end that is inserted in the bore 210 of the implant 102 to allow a user to hold the combined driver tool 108 and attached implant 102. The user may therefore use the implant driver tool 108 to move the implant 102 into the desired location in the bone without contacting the implant 102. FIG. 8C is a close up view of the end of the driver section 820 of the implant driver tool 108 shown in FIG. 8A showing a series of circumferential tips 822 extending from the exterior edge of the driving portion 820 of the working end 802. The diameter of the tips 822 in FIG. 8C are aligned with the counter bore 212 in the implant 102 to provide frictional contact thereby fixing the driver tool 108 to the implant 102.

[0075] The seal created by the interface 208 of the implant 102 with the abutment 104 creates the possibility of binding the abutment 104 to the implant 102 once assembled. In certain circumstances, such as replacement due to damage to the restoration, the abutment 104 requires removal from the implant 102. In some cases, the abutment 104 adheres to the implant 102 due to the sealing surfaces of the interface and cannot be removed manually. The abutment removal tool components 110 and 112 may then be used to insure that the abutment 104 may be removed without damaging or displacing the implant 102 if the abutment 104 remains adhered to the implant 102. As will be explained below, the abutment removal tool screw 112 is used in conjunction with the abutment removal insert tool 110 to engage the groove 328 within the through bore 326 of the abutment 104 as shown in FIG. 2C. The abutment removal tool screw 112 forces the abutment removal insert tool 110 into the

groove 328 in the bore 326 of the abutment 104. The abutment removal tool insert 110 is prevented from rotating by securing the insert 110 by a wrench that causes the screw 112 to push against the bottom of the inside of the implant 102 when the abutment removal tool screw 112 is turned. The resulting downward force applied by the screw 112 against the implant 102 frees the abutment 104 from the implant 102.

[0076] The abutment removal tool screw 112 is shown in FIGs. 9A–9C where FIG. 9A is a perspective view of the abutment removal tool screw 112, FIG. 9B is a side view of the abutment removal tool screw 112, and FIG. 9C is a front view of the abutment removal tool screw 112. The abutment removal tool screw 112 includes a proximal end 902 and a distal end 904. The proximal end 902 includes a grip section 906 that includes a ridged outer surface that allows a grip for turning the abutment removal tool screw 112. The grip section 906 may also be mated with a torque imparting tool such as a wrench to turn the abutment removal tool screw 112. The grip section 906 is connected to a thread section 908 that includes exterior threads 910 that may be engaged with a threaded interior surface of the abutment removal insert tool 110 shown in FIGs. 10A–10E. The thread section 908 is connected to a shaft 912 that extends to the distal end 904.

[0077] FIGs. 10A–10E show the abutment removal insert tool 110 where FIG. 10A is a perspective view of the abutment removal insert tool 110, FIG. 10B is a side view of the abutment removal insert tool 110, FIG. 10C is a cross-section side view of the abutment removal insert tool 110 along the line 10C-10C' in FIG. 10B, FIG. 10D is a front view of the abutment removal insert tool 110, and FIG. 10E is a back view of the abutment removal insert tool 110. The abutment removal insert tool 110 includes a distal end 1000 and a proximal end 1002. A multi-sided interface 1004 is formed on the distal end 1000 to provide an interface for a wrench. A cylinder 1006 extends from the distal end 1000 to the proximal end 1002. The cylinder 1006 forms an interior bore 1008. Two long notches 1010 are cut from the proximal end 1002 and two short notches 1012 are cut from the proximal end 1002 over part of the length of the cylinder 1006. An annular protrusion 1014 extends out from the cylinder 1006 at the members formed by the notches 1010 and 1012. The end of the interior bore 1008 on the proximal end 1002 includes an interior threaded surface 1020.

[0078] The process of removing the abutment 104 from the implant 102 using the abutment removal tool screw 112 and the abutment removal insert tool 110 is shown in FIGs. 11A–11E. FIG. 11A shows the abutment 104 and the implant 102 prior to connecting the

abutment 104 to the implant 102 via the screw 106. FIG. 11B shows the abutment 104 has been assembled to the implant 102 with an abutment screw 106. If it is desired to remove the abutment 104, the abutment screw 106 is removed with a driver tool such as a screwdriver. After the abutment screw 106 is removed, the abutment 104 is stuck to the implant 102 due to excessive side contact and/or interference from the interface described above with reference to FIGs. 4 and 5. As explained above, the abutment removal insert tool 110 in conjunction with the abutment removal tool screw 112 are used to remove the abutment 104 from the implant 102.

[0079] FIG. 11C shows the placement of the abutment removal insert tool 110 in the abutment 104. The protrusions 1014 at the distal end 1000 of the abutment removal insert tool 110 shown in FIG. 10A engage the groove 328 within the through-bore 326 of the abutment 104 shown in FIG. 3C. The abutment removal tool screw 112 is inserted in the interior bore 1008 of the abutment removal insert tool 110 and through the through-bore 326 of the abutment 104. The insertion of the abutment removal tool screw 112 in the interior bore 1008 of the abutment removal insert tool 110 forces the protrusions 1014 against the groove 328 thereby fixing the abutment removal insert tool 110 to the abutment 104.

[0080] FIG. 11D shows the resulting placement of the abutment removal tool screw 112 into the abutment removal insert tool 110. The exterior threads 910 of the thread section 908 engage the interior threaded surface 1020 of the abutment removal insert tool 110. The distal end 1000 of the removal tool screw 112 is inserted through the interior bore 1008 of the abutment removal insert tool 110 to the implant 102.

[0081] FIG. 11E shows the abutment removal insert tool 110 held with a wrench 1100 so that it and/or the implant 102 cannot rotate. A user then may grip the grip section 906 of the abutment removal tool screw 112 to turn the abutment removal tool screw 112. The distal end 1000 of the abutment removal tool screw 112 will contact the internal aspect of the implant 102. The resulting contact to the implant 102 will then apply a vertical force to the abutment 104 in relation to the implant 102 as further torque is applied to the abutment removal tool screw 112 translated through the thread section 908 to the interior threaded surface 1020 of the abutment removal insert tool 110. The abutment removal tool screw 112 is turned until the abutment 104 is freed from the implant 102.

[0082] Alternate designs may be made for each of the components shown in FIG. 1. For example, a different shaped driver tool may be used for the driver tool 108 such as the

driver tool 1200 shown in FIGs. 12A and 12B, where FIG. 12A is a perspective view of the implant driver tool 1200 and FIG. 12B is a close up view of the implant driver tool 1200 shown in FIG. 12A. The implant driver tool 108 includes a first end 1202 and a working end 1204 that is adapted to fit within the bore 210 of the implant 102. The first end 1202 includes a wrench interface 1206 that is spaced from a shaft 1208 to form an annular groove 1210. A resilient ring, such as an O-ring (not shown) is seated in the annular groove 1210 to help retain the implant driver tool 1200 in proper engagement with a torque wrench. The working end 1204 of the implant driver tool 1200 has a hexagonal male geometry driving portion 1220 adapted to mate with the socketed interior surface 220 of the anti-rotation cavity 214 of the implant 102.

[0083] FIG. 12B is a close up view of the implant driver tool 1200 shown in FIG. 12A showing a friction fit tapered nose 1222 that replaces the tips 822 shown in FIG. 8C. The tapered nose 1222 fits within the counter bore 212 of the implant 102 and serves to hold the implant driver tool 1200 to the implant 102 to allow a user to manipulate the implant 102 while maintaining sterility of the implant 102. The advantage of the shape of the tapered nose 1222 is ease of manufacture of the implant driver tool 108.

[0084] The implant driver tool 1200 shown in FIGs. 12A-12B may have alternative features of the tip to engage the implant to provide torque to the implant 102. An alternative tapered nose section 1250 is shown FIG. 12C which is a close up view of the tapered nose 1250 of the implant driver tool shown in FIG. 12A and FIG. 12D is a front view of the tip of the alternate tip configuration in FIG. 12C. Like elements are labeled with like element numbers in FIGs. 12C and 12D. The working end 1204 of the implant driver tool has a hexagonal male geometry driving portion 1220 adapted to mate with the socketed interior surface 220 of the anti-rotation cavity 214 of the implant 102. The alternative tapered nose 1250 has a circular bore 1252 as shown in FIG. 12D. The circular bore 1252 provides a reduction of the cross-sectional moment of inertia and reduces the stiffness of the tapered nose 1250 to decrease excessive contact between the tip and the implant 102.

[0085] FIG. 13A is a perspective view of an alternative implant driver tool 1300 that may be used instead of the implant driver tool 108 shown in FIG. 1. FIG. 13B is a side view of the implant driver tool 1300. The implant driver tool 1300 is adapted to mate with an anti-rotation cavity in an implant. When the implant driver tool 1300 is mated with the implant, the driver tool 1300 may be rotated to drive a threaded exterior surface of the implant into the

bone. The implant driver tool 1300 includes a first end 1310 and a working end 1312 that is adapted to fit within the bore of an implant. The first end 1310 is a grip section that includes a wrench interface 1314 that is spaced from a conical transition section 1316 to form an annular groove 1318. A resilient ring, such as an O-ring 1320, is seated in the annular groove 1318 to help retain the implant driver tool 1300 in proper engagement with a torque wrench. The implant driver tool 1300 has a shaft 1322 having a proximal end coupled to the grip section of the first end 1310 and a distal end that forms the working end 1312. The distal end of the shaft 1322 includes a hexagonal male geometry driver section 1330 adapted to mate with a socketed interior surface of the anti-rotation cavity of the implant. The contact between the driver section 1330 and the socketed interior surface of the implant allows the transition of torque force from the driver tool 1300 to the implant.

[0086] The wrench interface 1314 of the implant driver tool 1300 in this example has a four sided exterior surface to interface with a torque wrench that may be used to provide torque to turn the implant driver tool 1300 and thereby the implant to engage the threads on the exterior surface with the bone to seat the implant. In order to maintain sterile conditions, the implant is generally packed in a sterile package. The driver section 1330 includes an end that is inserted in the bore of the implant to allow a user to hold the combined driver tool 1300 and attached implant. The user may therefore use the implant driver tool 1300 to move the implant into the desired location in the bone without contacting the implant.

[0087] FIG. 13C is a close up view of the end of the driver section 1330 of the implant driver tool 1300 shown in FIG. 13B. FIG. 13D is a close up front view of the driver section 1330 along the line 13D-13D' in FIG. 13C. The driver section 1330 has six tabs 1332 that extend out from the body of the driver section 1330. The six tabs 1332 are formed between sidewalls 1334 that contact similar surfaces in the socketed interior surface of the implant to connect the driver 1300 with the implant. The tabs 1332 are inserted in slots that are formed on the socket interior surface that provide additional contact between the driver 1300 and the implant. The driver section 1330 therefore has six points of contact in the form of the sidewalls 1334 as well as additional contacts from the six tabs 1332 contacting corresponding slots in the socket portion of the implant.

[0088] While particular implementations and applications of the present disclosure have been illustrated and described, it is to be understood that the present disclosure is not limited to the precise construction and compositions disclosed herein and that various

modifications, changes, and variations can be apparent from the foregoing descriptions without departing from the spirit and scope of the invention as defined in the appended claims.

WHAT IS CLAIMED IS:

1. An abutment for use in conjunction with a dental implant, the abutment comprising:
a stem;
a post opposite of the stem;
an interior bore formed through the stem and the post; and
an interface section between the post and the stem for interfacing with the dental implant, the interface section terminating into a circular flat surface, the post extending from the circular flat surface, the circular flat surface interfacing with the dental implant
2. The abutment of claim 1, wherein the interface section has an annular radially curved exterior surface proximate to the post.
3. The abutment of claim 1, further comprising an annular groove cut into the circular flat surface to allow compliant fit of the interface section with a mating interior radially curved interface surface of the implant.
4. The abutment of claim 1, further comprising a circular groove in the interior bore in the post to accept an abutment removal tool.
5. The abutment of claim 1, wherein the stem includes an exterior interface surface with polygonal sides to lock into an anti-rotation cylinder in the implant.
6. A dental implant for use in conjunction with an abutment, the implant comprising:
a cylindrical body having an interior bore formed between a distal end and a proximal end;
an abutment interface on the proximal end of the cylindrical body, the interface including a flat annular stop surface circumferentially bordering the interior bore; and
an anti-rotational cavity formed in the interior bore proximal to the interface.
7. The dental implant of claim 6, wherein the abutment interface further includes a radial annular interior surface bordering the interior bore.
8. The dental implant of claim 6 further comprising an external screw thread on the exterior of the cylindrical body.
9. The dental implant of claim 6, wherein the interior bore includes a second cavity including internal screw threads to accept a screw attaching the implant to an abutment
10. The dental implant of claim 6, wherein the cavity has a polygonal interior wall.
11. The dental implant of claim 10, wherein the interior wall of the cavity forms a double sided hexagonal socket for attachment to an abutment.

12. The dental implant of claim 6, wherein the bore includes a groove to accept the tip of a screw tool to hold the dental implant via the contact with the groove.
13. A dental restoration system comprising:
an implant for attachment to a jaw bone of a patient, the implant including:
a cylindrical body having an interior bore formed between a distal end and a proximal end;
an abutment interface on the proximal end of the cylindrical body, the interface including a flat annular stop surface circumferentially bordering the interior bore;
an anti-rotational cavity formed in the interior bore proximal to the interface;
and
an abutment including:
a stem;
a post opposite the stem;
an interior bore formed through the stem and the post; and
an interface section between the post and the stem, the interface section interfacing with the abutment interface of the dental implant and having a circular flat surface.
14. The dental restoration system of claim 13, wherein the abutment interface includes a radial annular interior surface circumferentially bordering the interior bore and wherein the interface section of the abutment has an annular radially curved exterior surface proximate to the post, the radially curved exterior surface interfacing with the abutment interface of the dental implant.
15. An abutment for use in conjunction with a dental implant, the abutment comprising:
a stem;
a post opposite the stem;
an interior bore formed through the stem and the post; and
an interface section between the post and the stem, the interface section having an exterior surface proximate to the post, the exterior surface terminating into a circular flat surface, the post extending from the circular flat surface, an annular groove cut into the circular flat surface to allow compliant fit of the interface section with a mating interface surface of the implant.

16. The abutment of claim 15, wherein the exterior surface of the interface portion is radially curved to interface with an interior surface of the implant.
17. The abutment of claim 15, further comprising a circular groove in the interior bore in the post to accept an abutment removal tool.
18. The abutment of claim 15, wherein the stem includes an exterior interface surface with polygonal sides to lock into an anti-rotation cylinder in the implant.
19. An abutment for use in conjunction with a dental implant, the abutment comprising:
 - a stem;
 - a post opposite of the stem;
 - an interior bore formed through the stem and the post; and
 - an interface section between the post and the stem, the interface section having an annular radially curved exterior surface proximate to the post, the annular radially curved exterior surface for interfacing with the dental implant.
20. The abutment of claim 19, further comprising a circular flat surface having an annular groove to allow compliant fit of the interface section, the interface section terminating into the circular flat surface.
21. A dental restoration system comprising:
 - an implant for attachment to a jaw bone of a patient, the implant including:
 - a cylindrical body having an interior bore formed between a distal end and a proximal end;
 - an abutment interface on the proximal end of the cylindrical body;
 - an anti-rotational cavity formed in the interior bore proximal to the interface;
 - and
 - an abutment including:
 - a stem;
 - a post opposite the stem;
 - an interior bore formed through the stem and the post; and
 - an interface section between the post and the stem, the interface section interfacing with the abutment interface of the dental implant;
 - an abutment removal insert having a cylindrical end insertable into a groove formed in the interior bore of the abutment; and

an abutment removal tool screw insertable within the abutment removal insert, the abutment removal tool screw including a grip and an opposite end, the opposite end causing the abutment removal insert to contact the abutment, the grip being rotatable to cause the opposite end to create force against the implant to cause the abutment to be detached from the implant.

22. The dental restoration system of claim 21, further comprising an implant driver tool having a driver section mateable with the anti-rotation cavity of the implant for driving the implant into bone.

23. The dental restoration system of claim 12, wherein the interior bore of the implant includes a counter bore, and the implant driver tool includes an end extending from the driver section for contact with the counter bore to hold the implant to the driver tool.

24. The dental restoration system of claim 23, wherein the end is a tapered nose.

25. The dental restoration system of claim 23, wherein the end includes a plurality of circumferential tips.

26. An abutment removal tool system for removing an abutment from an implant, the abutment including an interior bore extending therethrough having a groove and an interface in contact with a corresponding interface on the implant, the system comprising:

an abutment removal insert having a cylindrical end insertable into a groove formed in the interior bore of the abutment; and

an abutment removal tool screw insertable within the abutment removal insert, the abutment removal tool screw including a grip end and an opposite end, the opposite end causing the abutment removal insert to contact the abutment, the grip being rotatable to cause the opposite end to create force against the implant to cause the abutment to be detached from the implant.

27. The abutment removal tool system of claim 26, wherein the cylindrical end of the abutment removal insert includes at least one notch.

28. The abutment removal tool system of claim 26, wherein the abutment removal insert includes an interior threaded surface, and wherein the abutment removal tool screw includes a threaded exterior surface on the opposite end that engages the interior threaded surface of the abutment removal insert.

29. The abutment removal tool system of claim 26, wherein the grip of the abutment removal tool screw is mateable with a wrench to impart rotational force on the abutment removal tool screw.
30. An implant driver tool for imparting rotational force to a dental implant including an exterior threaded surface and an interior bore having an anti-rotational cavity and a counter bore, the implant driver tool comprising:
- a shaft having a proximal end and a distal end including a driver section mateable with the anti-rotation cavity of the implant for driving the implant into bone;
 - an end attached to the driver section for contact with the counter bore to hold the driver tool to the implant; and
 - a grip section coupled to the proximal end of the shaft.
31. The implant driver tool of claim 30, wherein the end is a tapered nose.
32. The implant driver tool of claim 30, wherein the end includes a plurality of circumferential tips.
33. The implant driver tool of claim 30, wherein the grip section includes an annular groove seating an O-ring.
34. The implant driver tool of claim 30, wherein the grip section includes a multi-sided exterior surface for interface with a wrench to impart torque force to the implant driver tool.
35. The implant driver tool of claim 30, wherein the driver section has a hexagonal male geometry.
36. The implant driver tool of claim 30, wherein the end includes a flat front surface with a bore.
37. The implant driver tool of claim 30, wherein the end includes a plurality of flat sides that interface with corresponding surfaces on the anti-rotational cavity.
38. The implant driver tool of claim 37, wherein the end includes a plurality of exterior fins between the plurality of flat sides, the exterior fins corresponding to slots in the anti-rotational cavity.

1/11

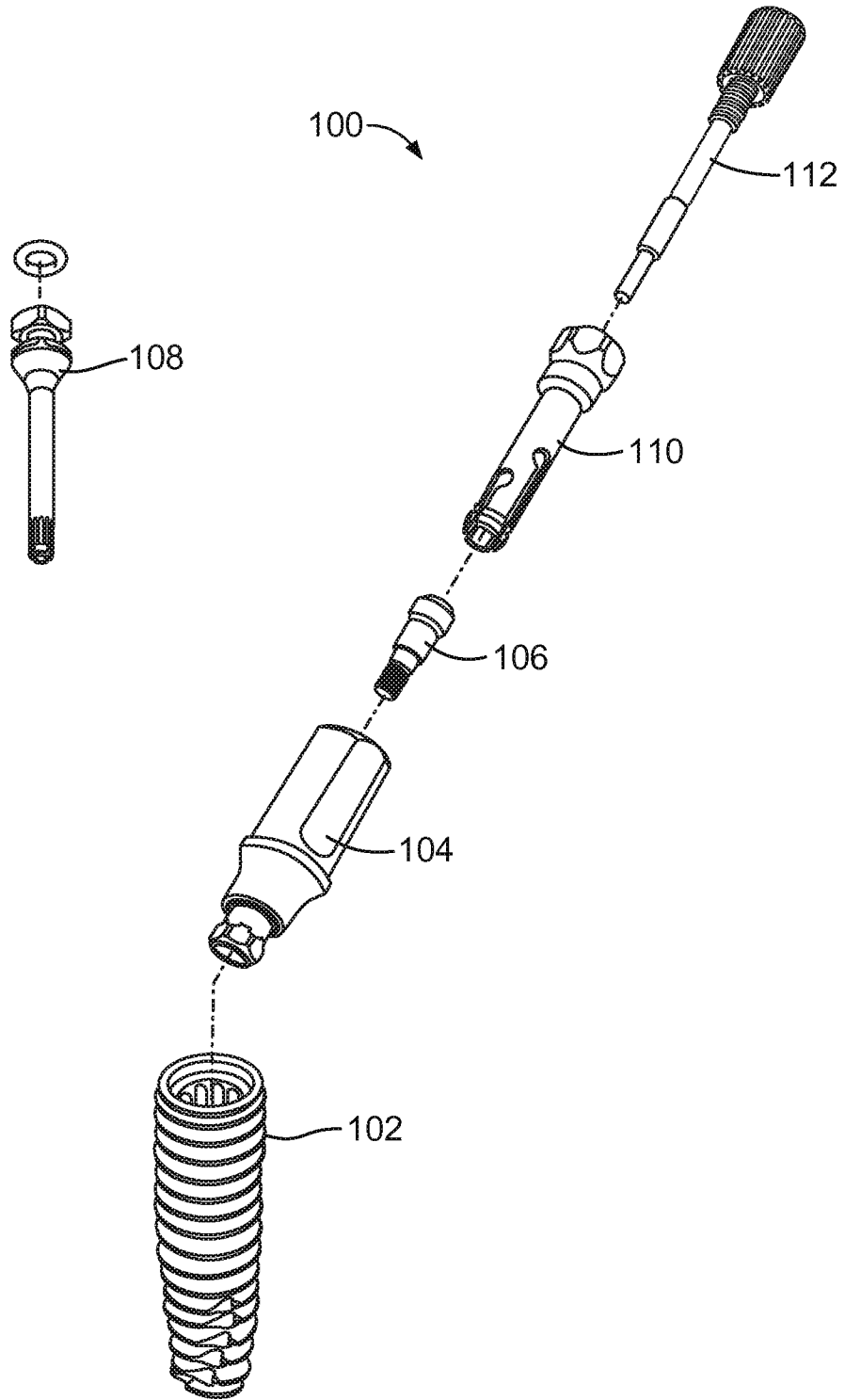

FIG. 1

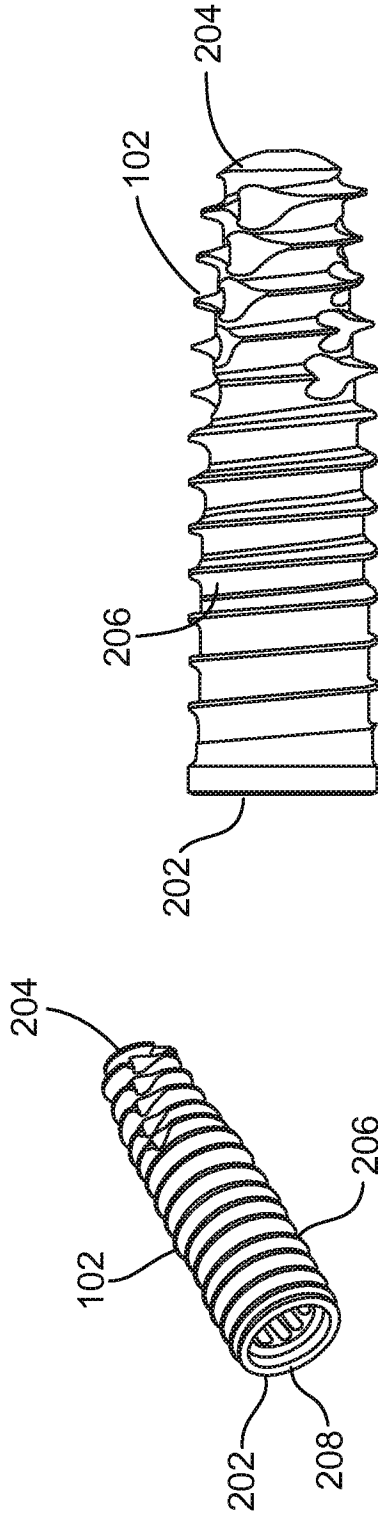

FIG. 2B

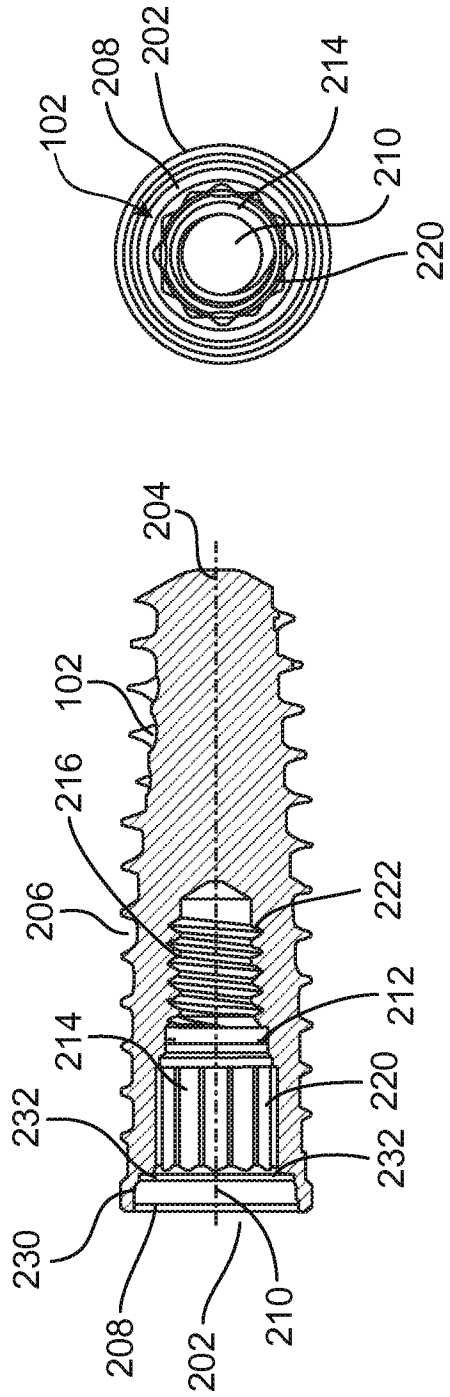

FIG. 2D

FIG. 2C

3/11

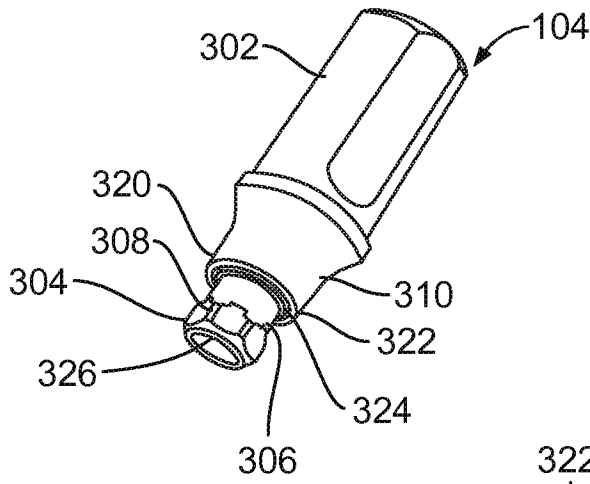

FIG. 3A

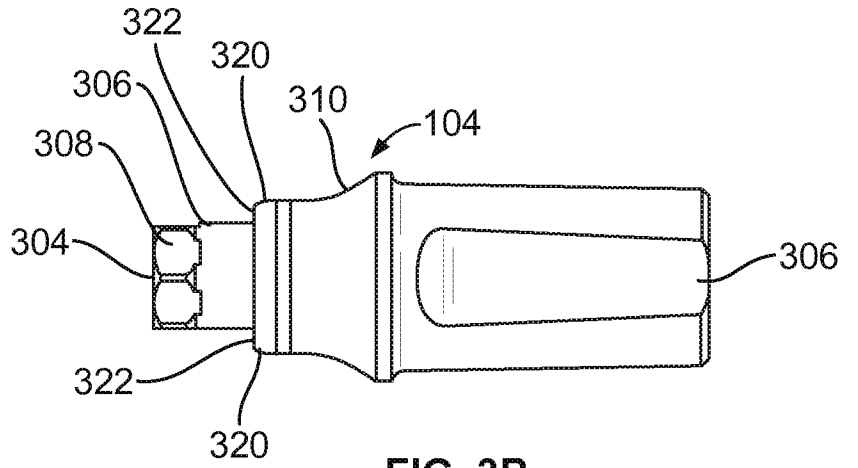

FIG. 3B

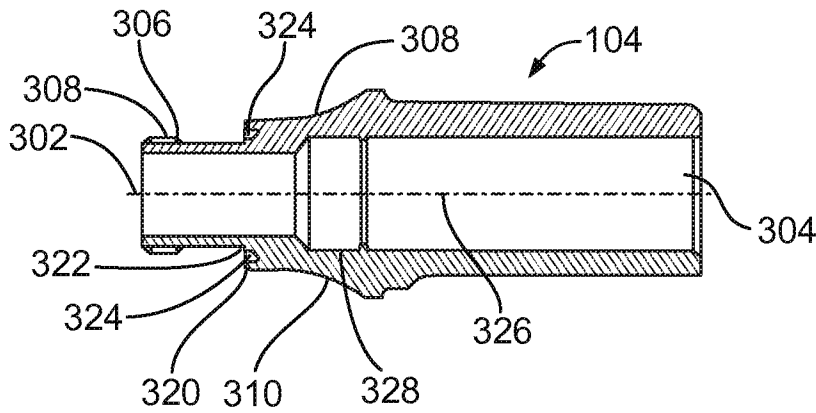

FIG. 3C

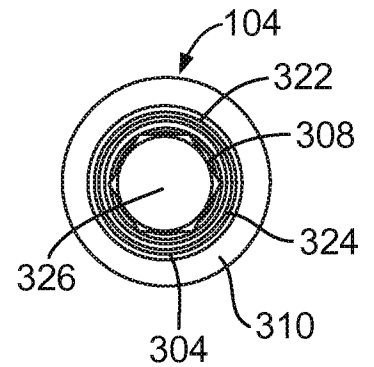

FIG. 3D

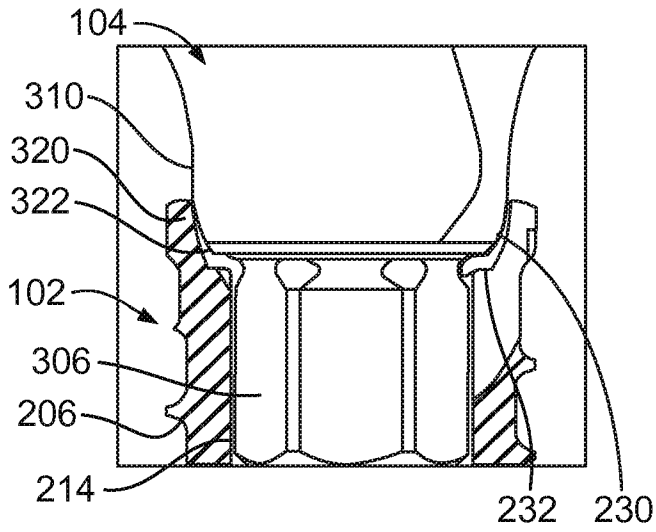

FIG. 4A

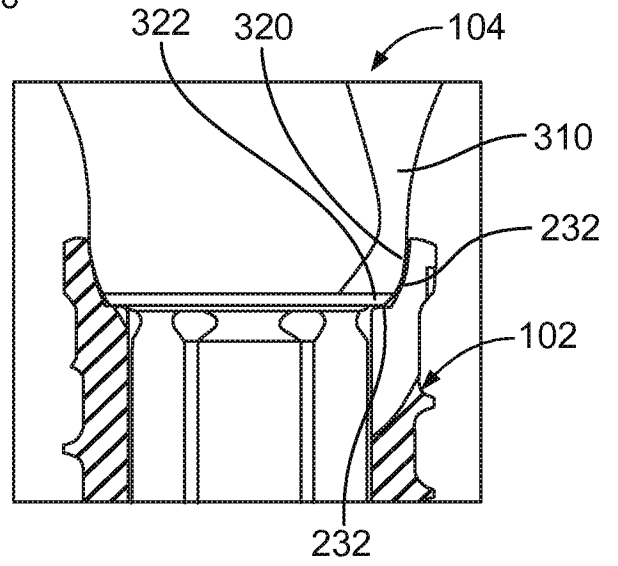

FIG. 4B

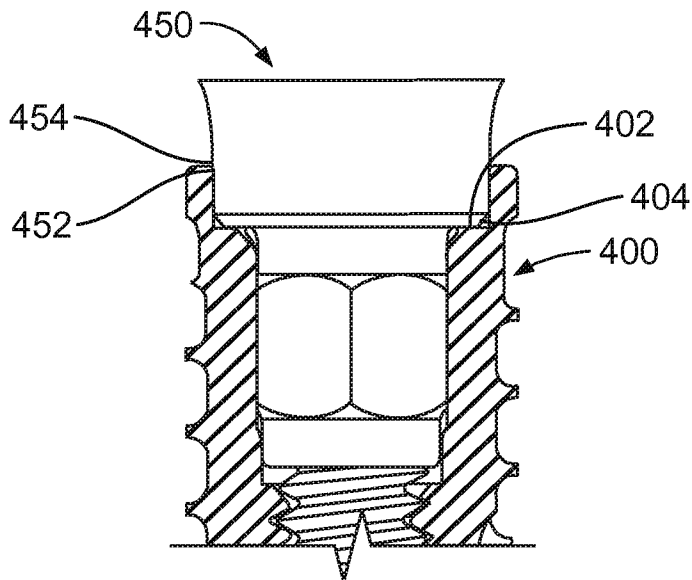

FIG. 4C

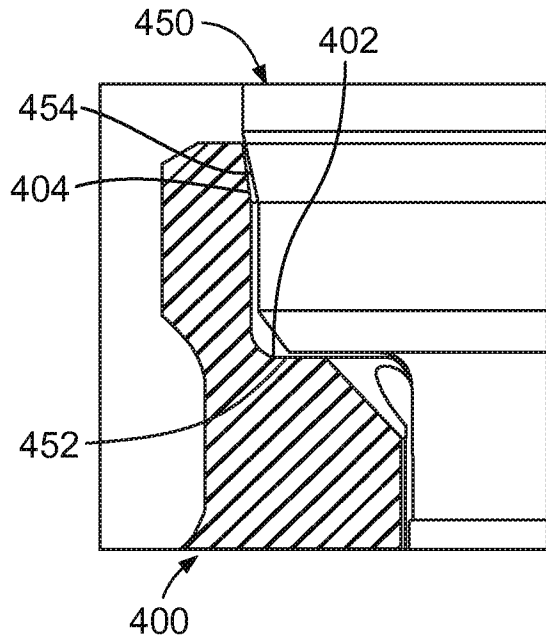

FIG. 4D

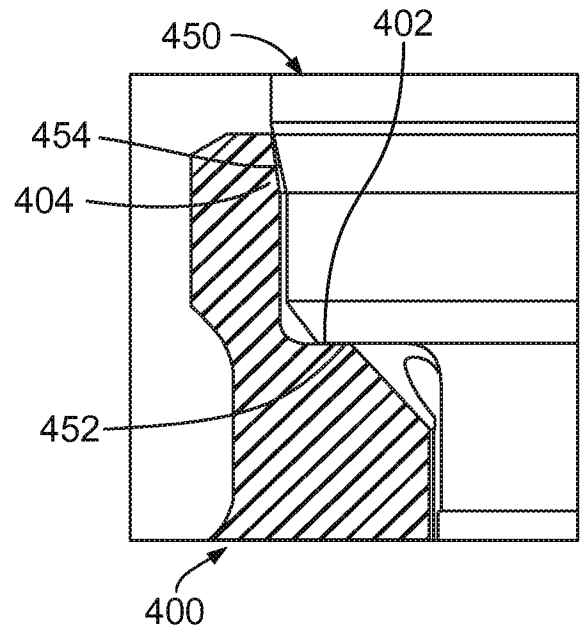

FIG. 4E

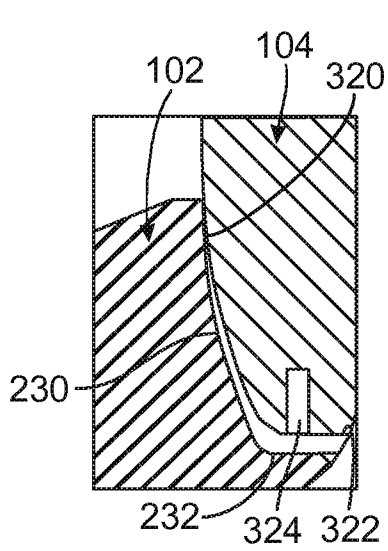

FIG. 5A

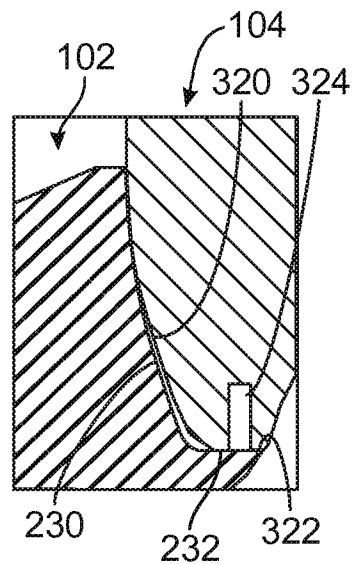

FIG. 5B

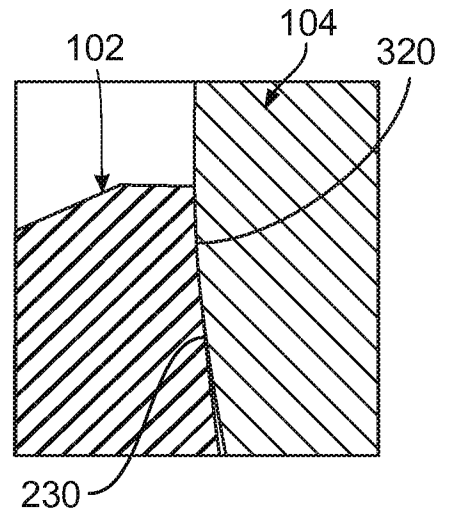

FIG. 5C

6/11

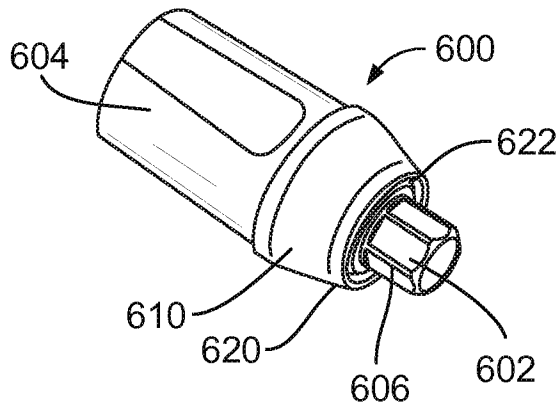

FIG. 6A

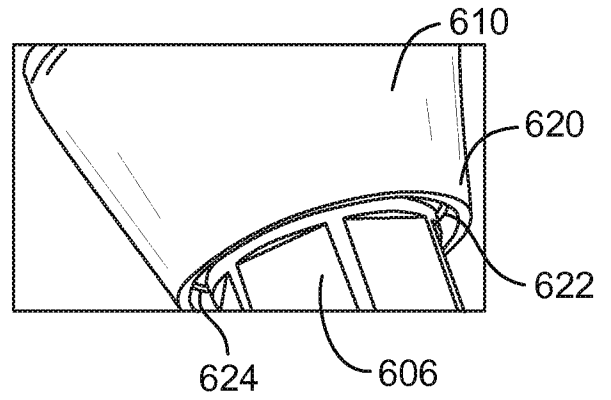

FIG. 6B

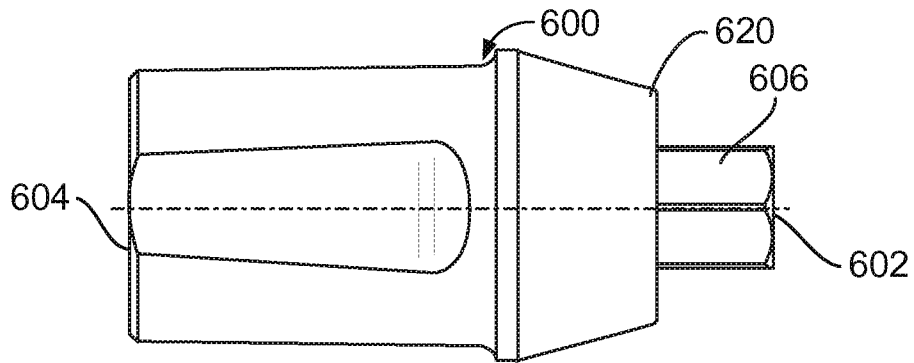

FIG. 6C

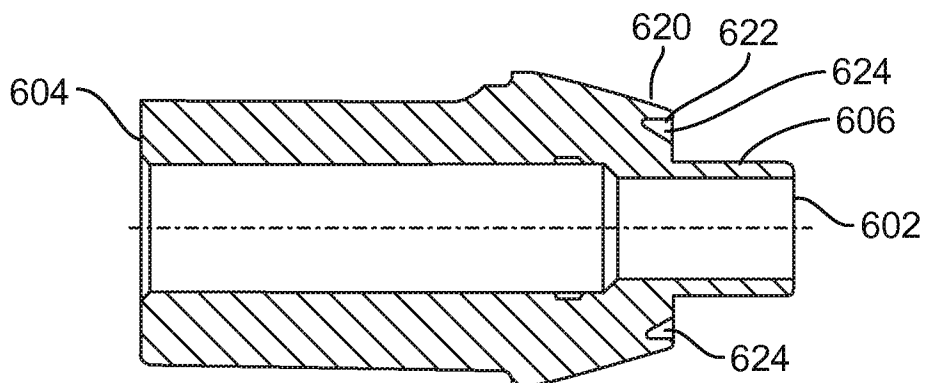

FIG. 6D

7/11

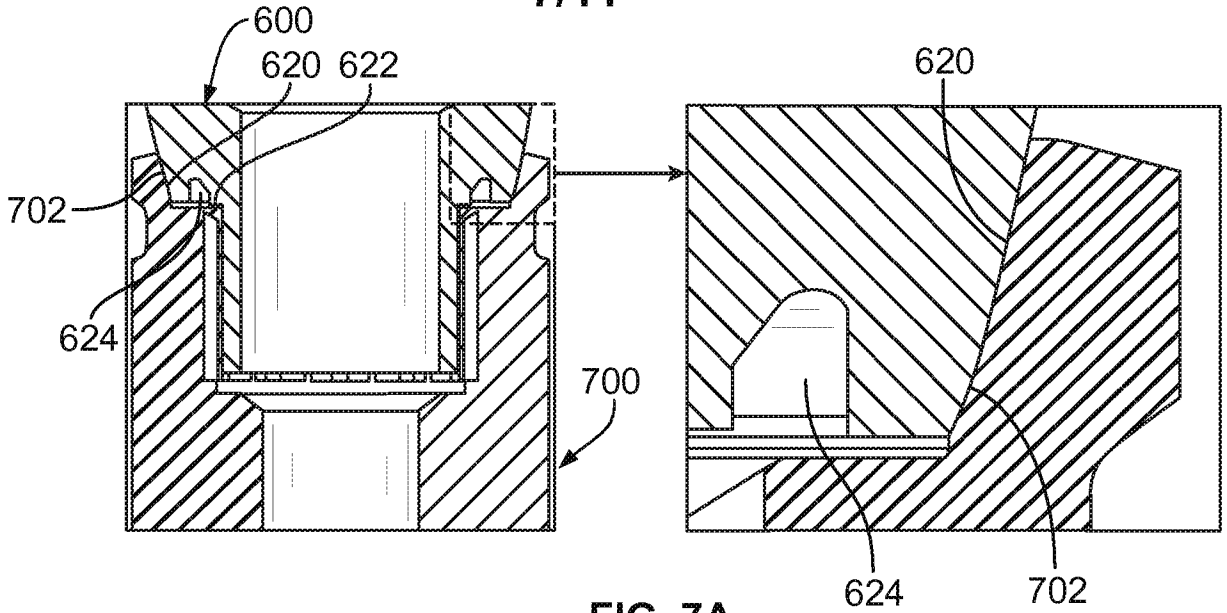

FIG. 7A

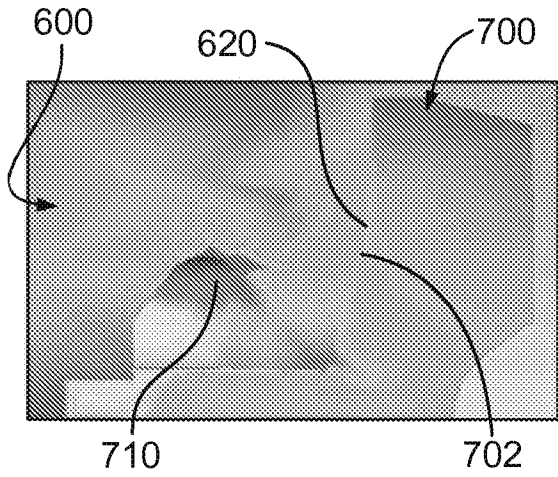

FIG. 7B

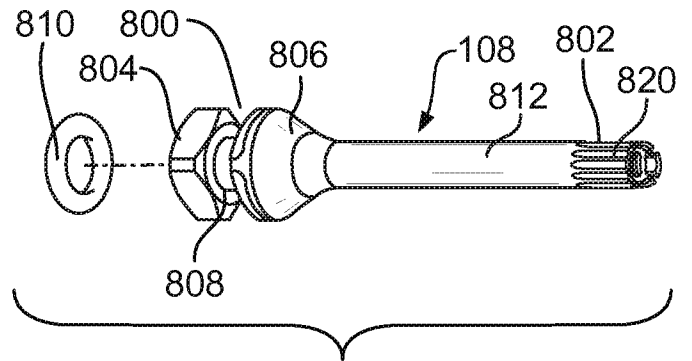

FIG. 8A

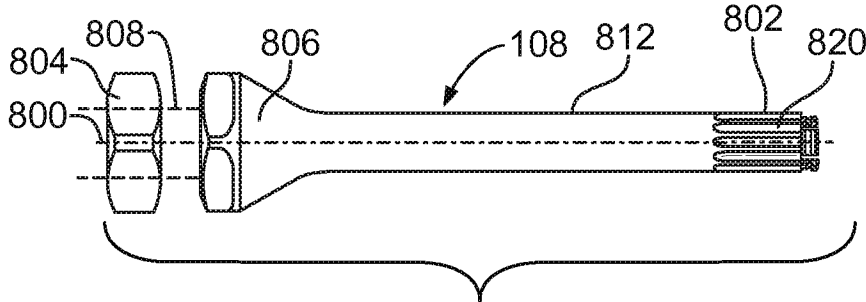

FIG. 8B

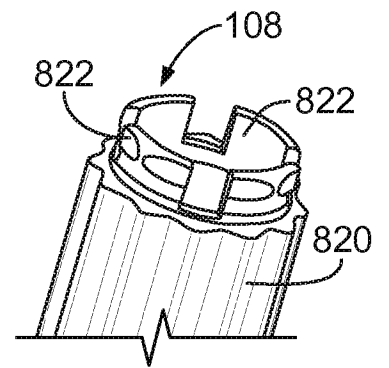

FIG. 8C

8/11

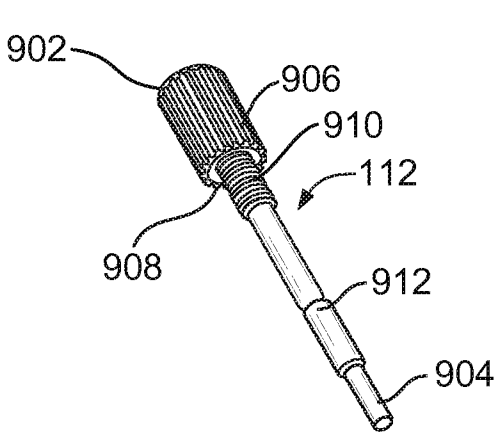

FIG. 9A

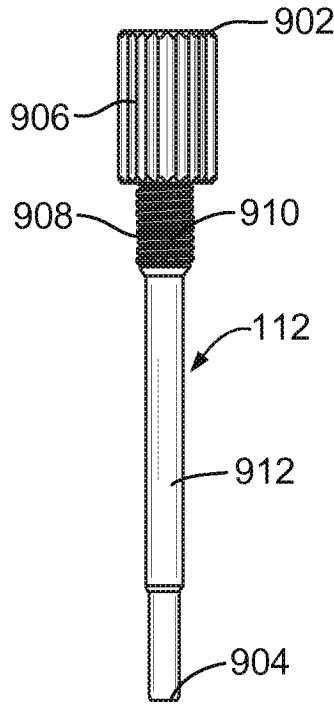

FIG. 9B

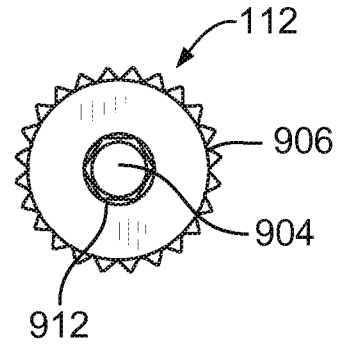

FIG. 9C

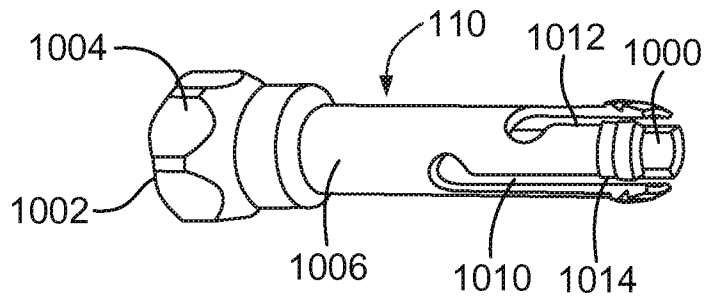

FIG. 10A

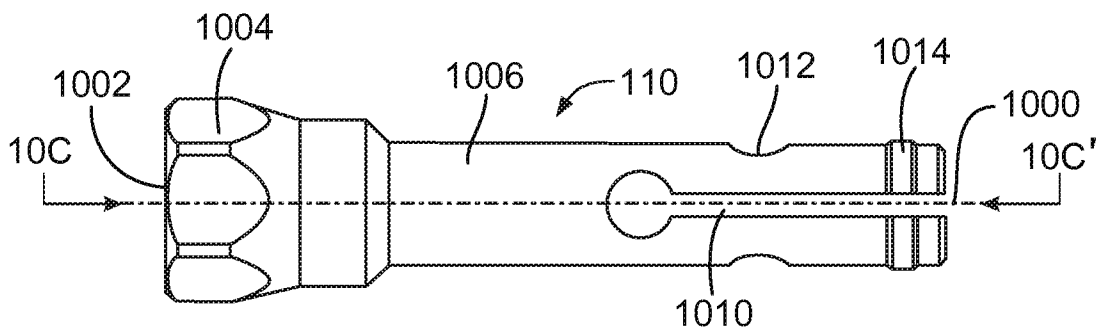

FIG. 10B

9/11

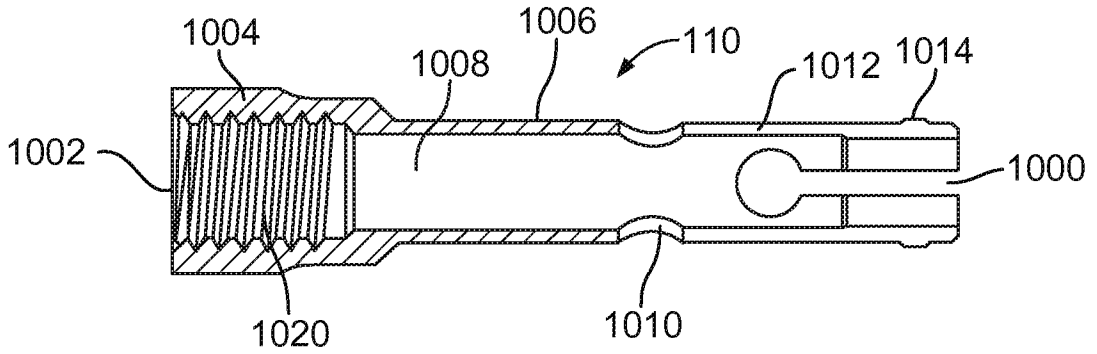

FIG. 10C

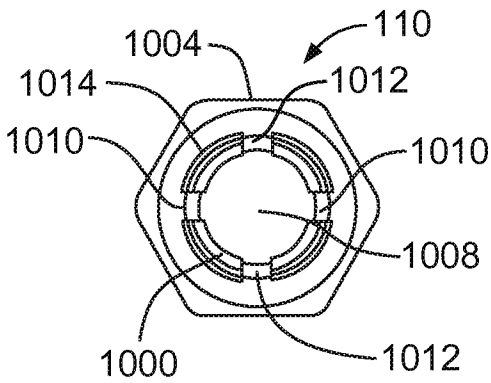

FIG. 10D

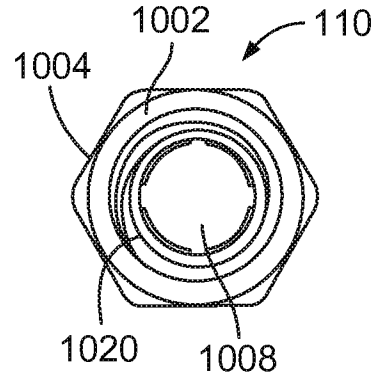

FIG. 10E

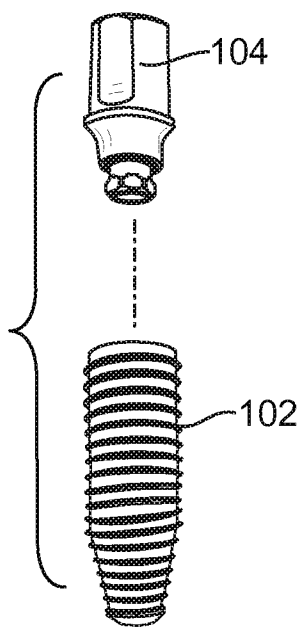

FIG. 11A

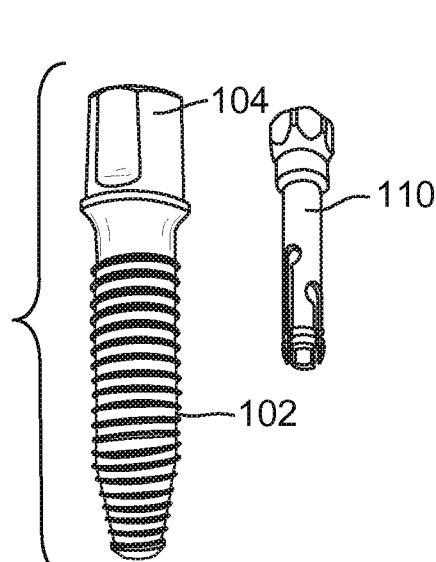

FIG. 11B

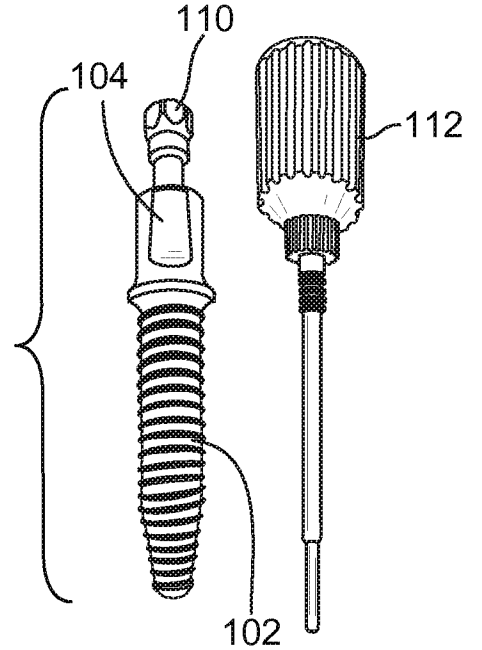

FIG. 11C

10/11

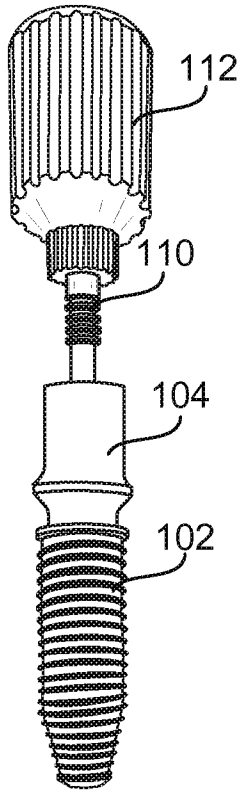

FIG. 11D

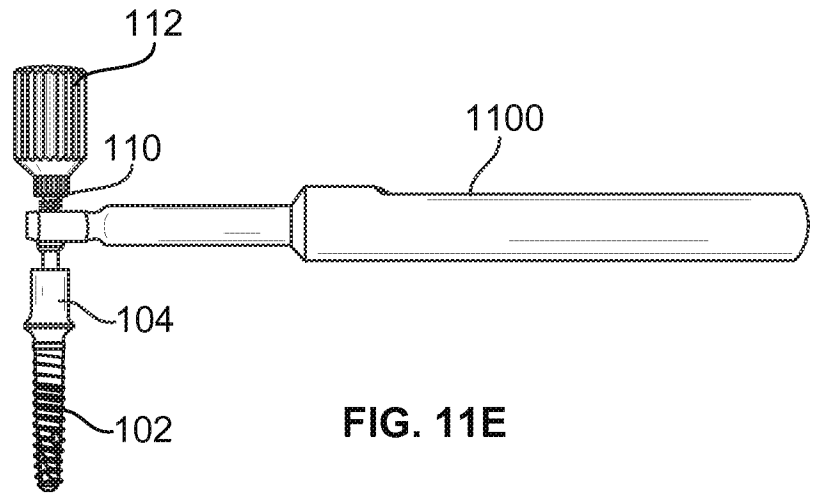

FIG. 11E

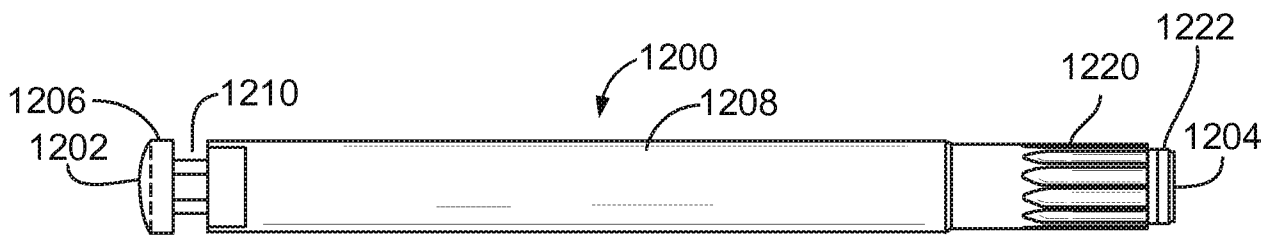

FIG. 12A

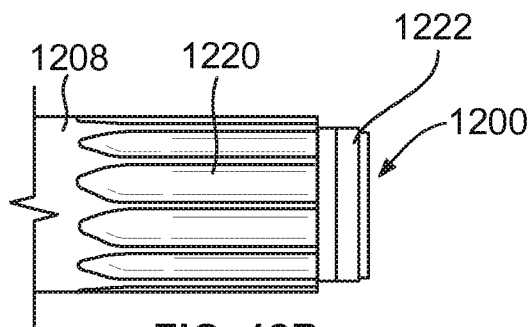
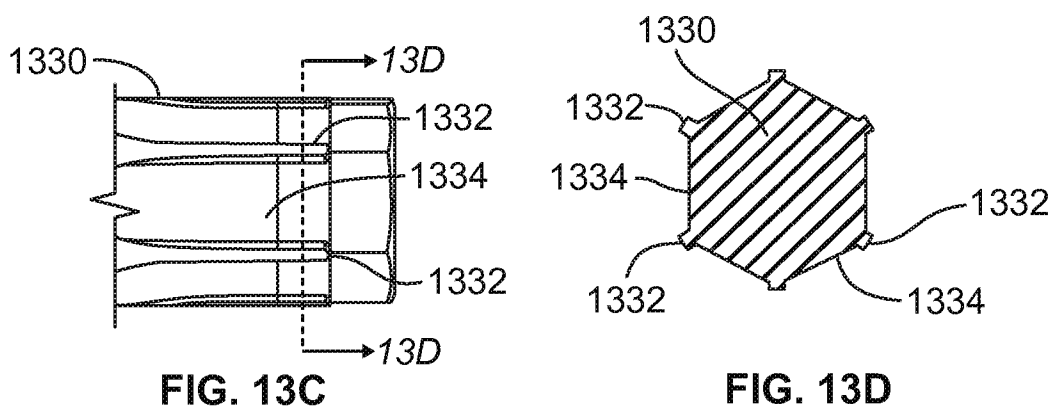
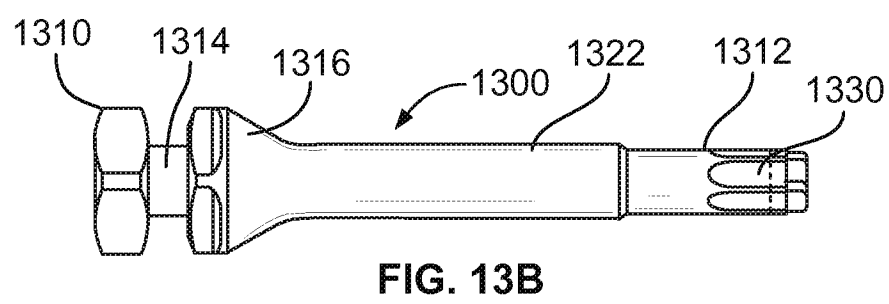
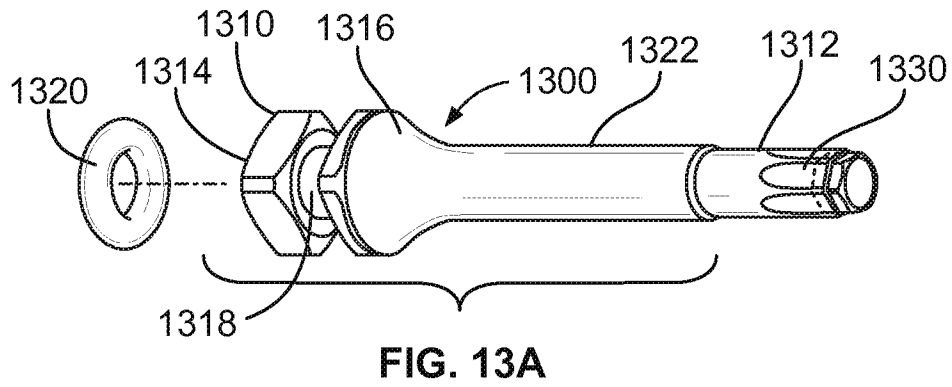
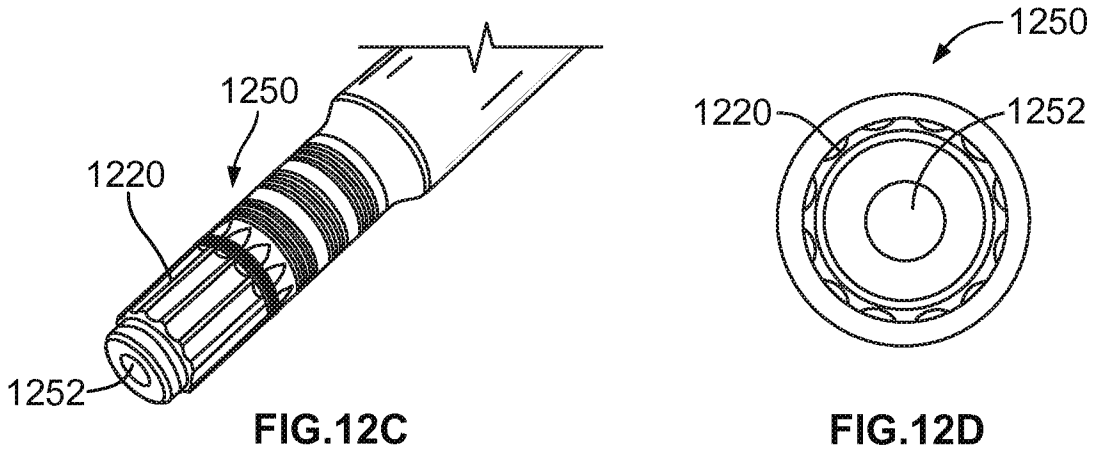

FIG. 12B

11/11



INTERNATIONAL SEARCH REPORT

International application No.

PCT/US2012/044308

A. CLASSIFICATION OF SUBJECT MATTER

IPC(8) - A61C 8/00 (2012.01)

USPC - 433/173

According to International Patent Classification (IPC) or to both national classification and IPC

B. FIELDS SEARCHED

Minimum documentation searched (classification system followed by classification symbols)

IPC(8) - A61C 8/00; 13/08 (2012.01)

USPC - 81/459; 411/386, 419, 426; 433/172, 173, 174, 176, 177, 191, 193, 201.1, 206, 220

Documentation searched other than minimum documentation to the extent that such documents are included in the fields searched

Electronic data base consulted during the international search (name of data base and, where practicable, search terms used)

PatBase, Google Patents

C. DOCUMENTS CONSIDERED TO BE RELEVANT

Category*	Citation of document, with indication, where appropriate, of the relevant passages	Relevant to claim No.
X ---	US 2009/0111072 A1 (LOMBARDO et al) 30 April 2009 (30.04.2009) entire document	1, 2, 4, 21, 26-29
Y		3, 5, 14-18, 22-25, 34
X ---	US 7,484,959 B2 (PORTER et al) 03 February 2009 (03.02.2009) entire document	6-13, 19, 30-31, 35, 37-38
Y		5, 14, 18, 20, 22-25, 32-34, 36
Y	US 6,666,685 B2 (FILHO) 23 December 2003 (23.12.2003) entire document	3, 15-18, 20
Y	US 6,206,696 B1 (DAY) 27 March 2001 (27.03.2001) entire document	23-25, 32
Y	US 2002/0025505 A1 (BEATY et al) 28 February 2002 (28.02.2002) entire document	33, 36

 Further documents are listed in the continuation of Box C.

* Special categories of cited documents:

"A" document defining the general state of the art which is not considered to be of particular relevance

"E" earlier application or patent but published on or after the international filing date

"L" document which may throw doubts on priority claim(s) or which is cited to establish the publication date of another citation or other special reason (as specified)

"O" document referring to an oral disclosure, use, exhibition or other means

"P" document published prior to the international filing date but later than the priority date claimed

"T" later document published after the international filing date or priority date and not in conflict with the application but cited to understand the principle or theory underlying the invention

"X" document of particular relevance; the claimed invention cannot be considered novel or cannot be considered to involve an inventive step when the document is taken alone

"Y" document of particular relevance; the claimed invention cannot be considered to involve an inventive step when the document is combined with one or more other such documents, such combination being obvious to a person skilled in the art

"&" document member of the same patent family

Date of the actual completion of the international search

06 September 2012

Date of mailing of the international search report

24 SEP 2012

Name and mailing address of the ISA/US

Mail Stop PCT, Attn: ISA/US, Commissioner for Patents

P.O. Box 1450, Alexandria, Virginia 22313-1450

Facsimile No. 571-273-3201

Authorized officer:

Blaine R. Copenheaver

PCT Helpdesk: 571-272-4300

PCT OSP: 571-272-7774