

BAMFORD & TATE, Jr.

2 Sheets—Sheet 1.

Stove.

No. 48,037.

Patented June 6, 1865.

Fig. 1.

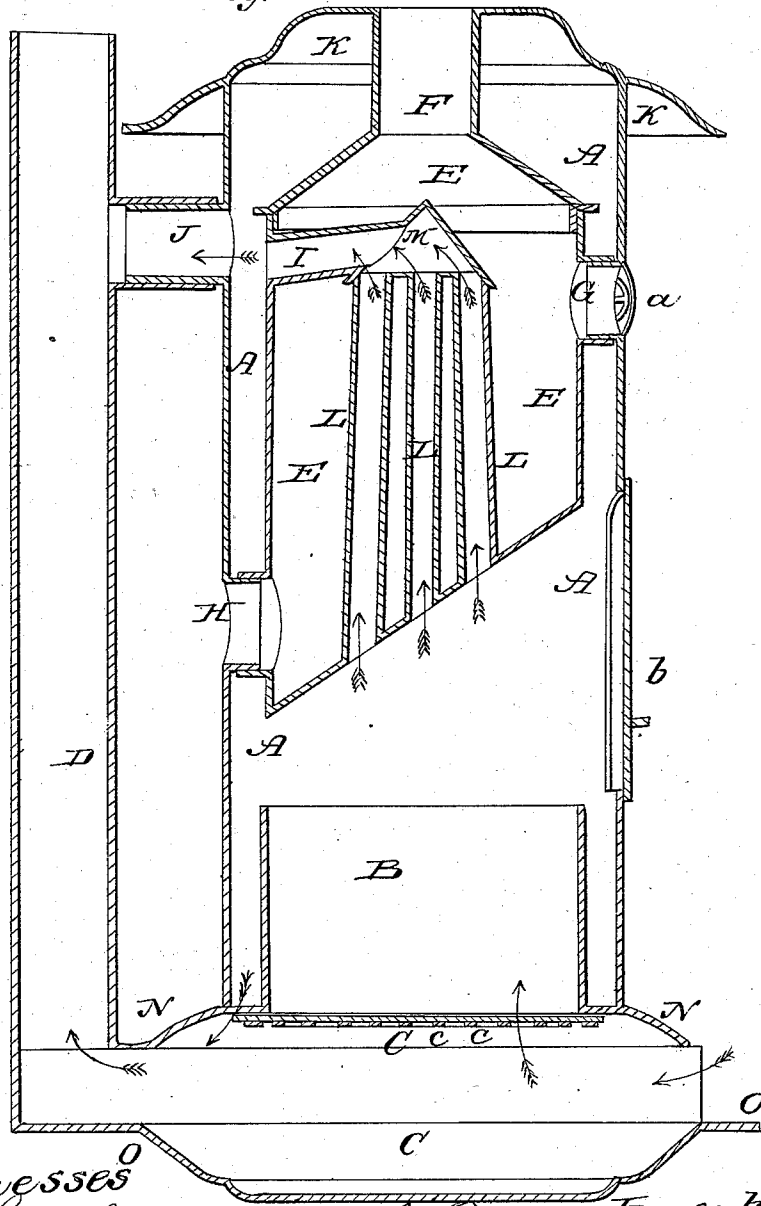

Witnesses
J. S. Clark
J. Foley

Inventor
William Bamford
John T. Tate

BAMFORD & TATE, Jr.

Stove.

No. 48,037.

Patented June 6, 1865.

Fig. 2

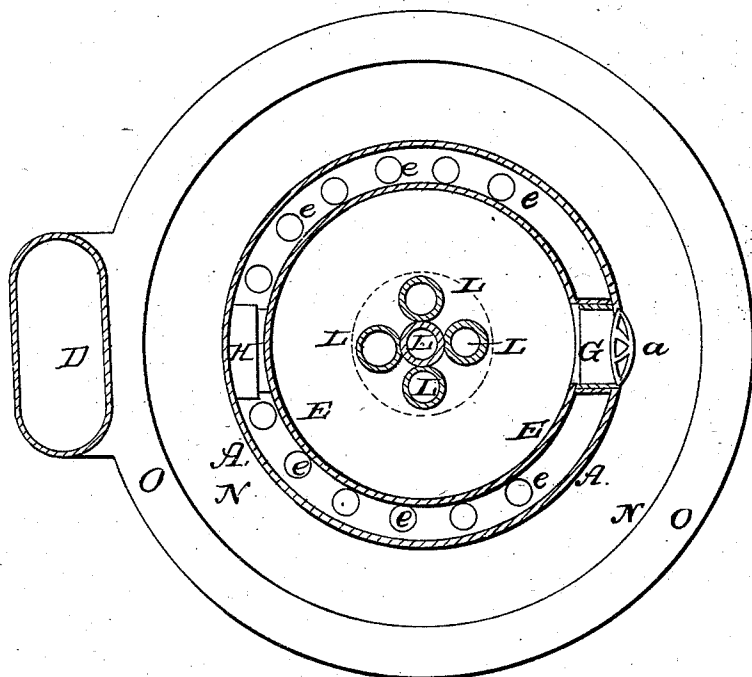

Witnesses
 L. S. Clark
 J. Foley

Inventor
 William Bamford
 John T. Tate, Jr.

UNITED STATES PATENT OFFICE.

WILLIAM BAMFORD AND J. F. TATE, JR., OF MILWAUKEE, WISCONSIN.

STOVE.

Specification forming part of Letters Patent No. 48,037, dated June 6, 1865.

To all whom it may concern:

Be it known that we, WILLIAM BAMFORD and JOHN F. TATE, Jr., of the city of Milwaukee, county of Milwaukee, and State of Wisconsin, have invented certain new and useful Improvements in Stoves; and we do hereby declare that the following is a full, clear, and exact description of the construction and operation of the same, reference being had to the accompanying drawings, making a part of this specification, in which—

Figure 1 is a vertical section of an ordinary stove with our improvements inserted, and Fig. 2 a lateral section of the same.

Like letters refer to similar parts in both figures.

The nature of our invention consists in providing the upper portion of an ordinary stove with an air-chamber, having pipes or flues inserted in it and connected with the main pipe or flue; in providing such air-chamber with an opening which connects it directly with the outer air, and also attaching hot-air registers, and in new and useful combinations of the several parts, as claimed.

To enable others skilled in the art to make and use our invention, we will proceed to describe the construction and operation of our improvements.

We construct our stoves in any of the known forms, except that in some of them a greater height is required. In the form shown the stove A is made of sheet-iron and provided with a cast-iron cap, K, bases N and O, fire-box B, grate *c*, and ash-pan C in the usual manner of stoves of that construction. Near the upper end of the case A we insert the air-chamber E, which is supported by resting on the pipe or orifice H and the register G, and held in place by the pipe F. It may, however, be held in place by arms or any other suitable device. In the form shown the bottom of the air-chamber is inclined from the horizontal, for two reasons. These are to give a more perfect use of the door *b*, and, as the back of a stove is usually near a wall, to incline the draft and heat forward; but if the stove is of sufficient height the bottom can be made on a plane with the base of the stove. The interior of the air-chamber is provided with fire flues or pipes L, the number being increased or diminished, according to the diameter or size of the stove. These flues are

brought together or into a smoke-chamber at M, and from that point are discharged into the space between the chamber E and the stove A or into the pipe J by means of the flue or pipe I. A portion of the heat and smoke from the fire passes through these flues L L, while the balance passes over and around the air-chamber and between it and the outer case of the stove A, thus giving a great heating surface and power to the air-chamber. The air-chamber is connected directly with the outer air by means of the opening or tube H. The air is heated rapidly and without consuming its oxygen, as it is in no place brought in contact with any flame, and when heated passes out of the register G or F. When only a single room is desired to be heated, one register will be sufficient. If it should be desirable to warm an upper room or rooms, a pipe will be attached at F and carried up through the floor. If an adjoining one, a pipe will be attached at G and carried through the wall, as it will be seen that the register G can be attached as well at the back or sides as to the front. A number of rooms can be heated from a usual-sized stove, as by reason of our great heating-surface we can pass a strong current of air rapidly through the air-chamber and heat it sufficiently hot to warm them in a few minutes.

Our device or improvements can easily be attached to most stoves now in use and to those where the main pipe D connects by an elbow at J, as well as to those where it is connected with the base, as shown. It will readily be seen that this device greatly economizes the heat, as it is placed far enough from the case A to prevent injuring that as a radiating-surface, and uses the central heat of the stove, which is otherwise wasted or nearly lost. It is adapted to either coal or wood stoves. This device varies in size, form, and dimensions, according to the size or form of the stove in which it is placed. The holes *e e* shown in Fig. 2 are draft and air passages at the base of the stove, between the fire-box B and the case A. Our device can also be inserted into the pipe by simply putting the pipe I on the top of the smoke-chamber M, and we also claim it for that purpose.

Having thus fully described our invention, what we claim, and desire to secure by Letters Patent, is—

1. The air-chamber E, provided with one or more draft-flues, L L, discharging into the main pipe or flue D.

2. The flues L L and pipe I, in combination with an air-chamber placed inside of a stove.

3. The opening or pipe H, when used for passing the outer air through a heated space and into an inner chamber provided with flues, as specified.

4. The air-chamber E, flues L L, pipe I, pipe

or orifice H, and register G or F, in combination with the outer case or stove, A—each of said parts and combinations being substantially as set forth and specified.

WILLIAM BAMFORD.
JOHN F. TATE, JR.

Witnesses:

I. S. CLARK,
J. FOLEY.