

(No Model.)

J. A. MURRAY.
INVALID'S DRINKING VESSEL.

No. 455,452.

Patented July 7, 1891.

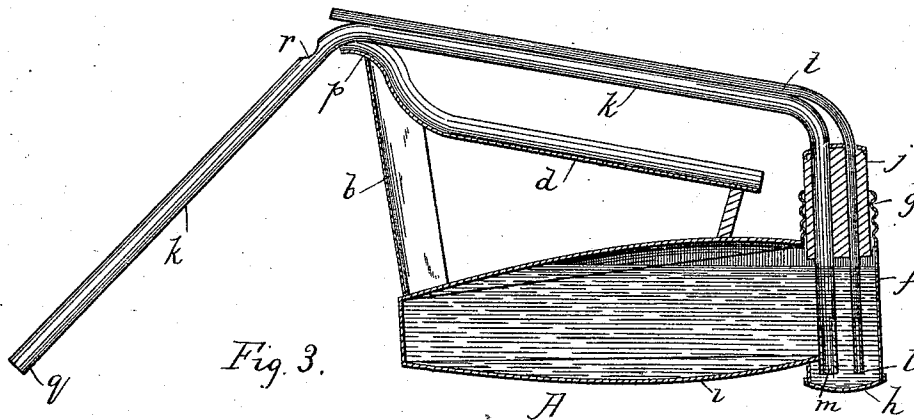
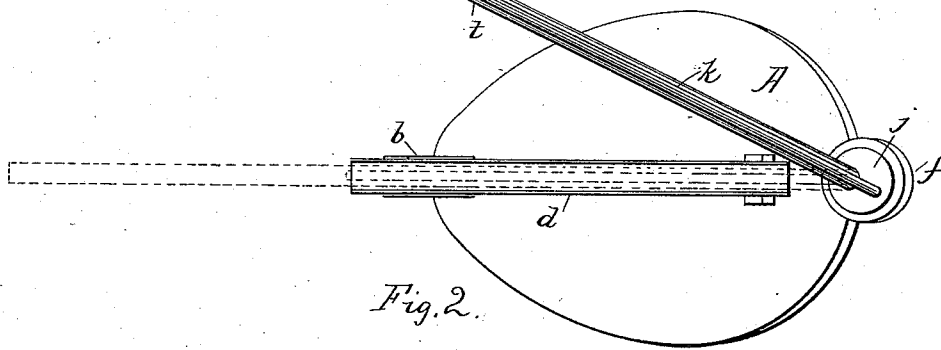
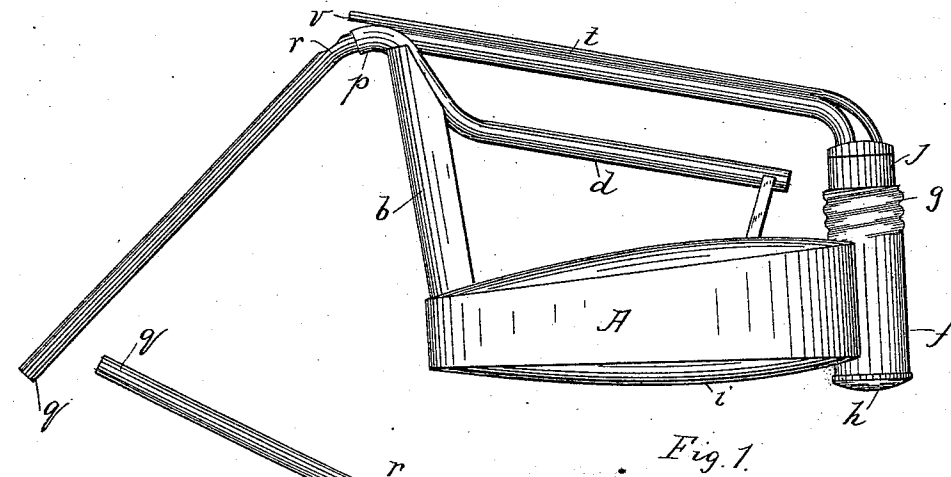

WITNESSES

M. J. Cogan.
W. Duffel

INVENTOR
John A. Murray,
By C. A. Shaw & Co.,
ATTYS

UNITED STATES PATENT OFFICE.

JOHN A. MURRAY, OF WINCHESTER, MASSACHUSETTS.

INVALID'S DRINKING-VESSEL.

SPECIFICATION forming part of Letters Patent No. 455,452, dated July 7, 1891.

Application filed April 21, 1891. Serial No. 389,781. (No model.)

To all whom it may concern:

Be it known that I, JOHN A. MURRAY, of Winchester, in the county of Middlesex, State of Massachusetts, have invented certain new and useful Improvements in Drinking-Vessels for Invalids and Children, of which the following is a description sufficiently full, clear, and exact to enable any person skilled in the art or science to which said invention appertains to make and use the same, reference being had to the accompanying drawings, forming part of this specification, in which—

Figure 1 is a side elevation of my improved drinking-vessel; Fig. 2, a top plan view, and Fig. 3 a vertical longitudinal section, of the same.

Like letters of reference indicate corresponding parts in the different figures of the drawings.

My invention relates especially to a device whereby invalids or others in reclining position may be enabled to drink from a vessel without spilling the contents; and it consists in certain novel features hereinafter fully set forth and claimed, the object being to produce a simpler, cheaper, and more effective device of this character than is now in ordinary use.

The nature and operation of the improvement will be readily understood by all conversant with such matters from the following explanation.

In the drawings, A represents the body of the vessel, which may be of any suitable form and construction, and which is represented as a metallic tank oval or egg-shaped in top plan view.

At the forward end of the body a vertical standard *b* is mounted, to which a curved handle *d* is secured.

At the rear or large end of the tank a tubular portion *f* is formed, the upper end being spirally fluted or screw-threaded at *g*, and its lower end *h* extending below the bottom *i* of said tank. A plug *j* closes the mouth of said tube. A discharge-pipe *k* passes through said plug, its lower end opening within the tank at *m*, below the bottom *i* thereof and in the bottom of the tubular por-

tion *f*, as shown in Fig. 3. Said pipe is bent longitudinally to project over the body, and rests loosely in the handle *d* at *p*, said handle being grooved in this portion to receive said tube. The tube at this point is bent vertically downward until its mouth *q* is practically in the same plane as the bottom *i* of the tank. Near the standard *b* and directly below the vertical bend in the pipe a vent-opening *r* is formed in said tube. A vent-pipe *t* has one end *v* opening near said vent *r*, said pipe extending parallel with the tube *k* through the plug *j*, and opening at *l* under the bottom of the tank *i*.

In the use of my improvement the vessel is filled through the nipple *g*, the plug *j* being removed. The operator then grasps the handle *d*, closing the vent *r* with the thumb. The mouth *q* of the pipe *k* is inserted in the mouth of the invalid, a suitable mouth-piece or rubber nipple being employed on said tube, if desired. Air passing into the body of the tank through the pipe *t* permits the contents of said tank to be readily withdrawn through the tube *k*. Said tube can be swung laterally from the handle *d*, as shown in Fig. 2, and its peculiar form enables the tank to be tipped into any desired position convenient for the user. As soon as the thumb is removed from the vent *r* air passing therein prevents further flow of the liquid from the tank, the portion in that part of the tube between said vent and the mouth *q* readily flowing into the mouth of the user and preventing spilling or dripping of the contents when said tube is removed. The elongated air-pipe *t* prevents the contents of the tank from flowing through said pipe when the tank is inverted or tipped to discharge the contents of the tube *k*.

Having thus explained my invention, what I claim is—

1. In a device of the character described, the body or tank for containing liquid, in combination with a bent or irregular discharge-tube opening into said tank below its bottom, and provided outside of said tank with a vent-opening, substantially as described.

2. In a drinking-vessel for invalids, a bent

or curved discharge-tube provided with a vent-opening outside said vessel, substantially as and for the purpose set forth.

3. In a device of the character described, a
5 body, in combination with a discharge-tube opening into said body below its bottom and provided with a vent adapted to be closed by

the finger, and an elongated air-tube opening into said body, substantially as described.

JOHN A. MURRAY.

Witnesses:

O. M. SHAW,
K. DURFEE.