

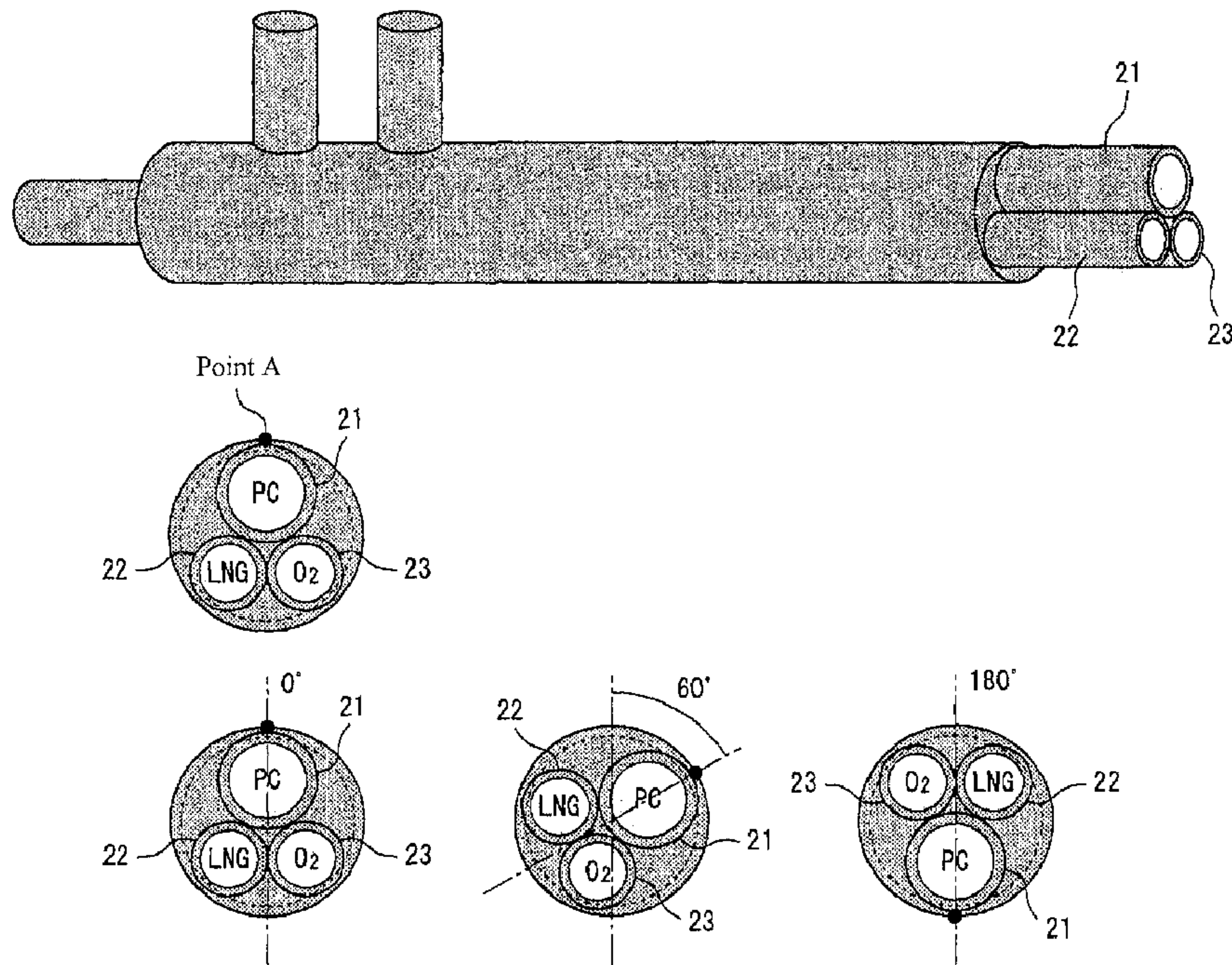

(86) **Date de dépôt PCT/PCT Filing Date:** 2014/03/27
 (87) **Date publication PCT/PCT Publication Date:** 2014/10/09
 (45) **Date de délivrance/Issue Date:** 2017/01/24
 (85) **Entrée phase nationale/National Entry:** 2015/09/22
 (86) **N° demande PCT/PCT Application No.:** JP 2014/058797
 (87) **N° publication PCT/PCT Publication No.:** 2014/162965
 (30) **Priorité/Priority:** 2013/04/03 (JP2013-077523)

(51) **Cl.Int./Int.Cl. C21B 7/00** (2006.01),
C21B 5/00 (2006.01)
 (72) **Inventeurs/Inventors:**
FUJIWARA, DAIKI, JP;
MURAO, AKINORI, JP;
KAJISA, TAKESHI, JP;
TOKUDOME, MITSUSHI, JP
 (73) **Propriétaire/Owner:**
JFE STEEL CORPORATION, JP
 (74) **Agent:** ROBIC

(54) **Titre : PROCÉDE D'EXPLOITATION DE HAUT-FOURNEAU ET LANCE**
 (54) **Title: BLAST FURNACE OPERATION METHOD AND LANCE**



(57) **Abrégé/Abstract:**

[Problem] To provide a blast furnace operation method and a lance making it possible to improve cooling power, improve the combustion quality of pulverized coal blown in from a tuyere, and reduce the unit consumption of the reducing agent. [Solution] A

(57) Abrégé(suite)/Abstract(continued):

blast furnace operation method in which a solid reducing agent, a flammable gaseous reducing agent, and a combustion-sustaining gas are blown from a tuyere into the furnace through a lance, wherein: a parallel-type lance in which three independent blowing tubes are bundled in parallel and integrated with an outer tube is used; the gaseous reducing agent and/or the combustion-sustaining gas, and the solid reducing agent, are simultaneously blown in through the respective blowing tubes; and the blowing-in from the parallel-type lance is performed in an orientation in which the solid reducing agent blowing tube and the gaseous reducing agent blowing tube are positioned above the combustion-sustaining gas blowing tube. In addition, a lance structure used in the blast furnace operation method.

(12) 特許協力条約に基づいて公開された国際出願

(19) 世界知的所有権機関
国際事務局(43) 国際公開日
2014年10月9日(09.10.2014)(10) 国際公開番号
WO 2014/162965 A1

- (51) 国際特許分類:
C21B 7/00 (2006.01) C21B 5/00 (2006.01) 町二丁目2番3号 JFEスチール株式会社
知的財産部内 Tokyo (JP).
- (21) 国際出願番号: PCT/JP2014/058797 (74) 代理人: 特許業務法人銀座マロニエ特許事務所
(GINZA MARONIE P.C.); 〒1040061 東京都中央区
銀座2丁目8番9号木挽館銀座ビル Tokyo (JP).
- (22) 国際出願日: 2014年3月27日(27.03.2014)
- (25) 国際出願の言語: 日本語 (81) 指定国 (表示のない限り、全ての種類の国内保
護が可能): AE, AG, AL, AM, AO, AT, AU, AZ, BA,
BB, BG, BH, BN, BR, BW, BY, BZ, CA, CH, CL, CN,
CO, CR, CU, CZ, DE, DK, DM, DO, DZ, EC, EE, EG, ES,
FI, GB, GD, GE, GH, GM, GT, HN, HR, HU, ID, IL, IN,
IR, IS, JP, KE, KG, KN, KP, KR, KZ, LA, LC, LK, LR,
LS, LT, LU, LY, MA, MD, ME, MG, MK, MN, MW, MX,
MY, MZ, NA, NG, NI, NO, NZ, OM, PA, PE, PG, PH,
PL, PT, QA, RO, RS, RU, RW, SA, SC, SD, SE, SG, SK,
SL, SM, ST, SV, SY, TH, TJ, TM, TN, TR, TT, TZ, UA,
UG, US, UZ, VC, VN, ZA, ZM, ZW.
- (26) 国際公開の言語: 日本語 (84) 指定国 (表示のない限り、全ての種類の広域保
護が可能): ARIPO (BW, GH, GM, KE, LR, LS, MW,
MZ, NA, RW, SD, SL, SZ, TZ, UG, ZM, ZW), ユーラシ
ア (AM, AZ, BY, KG, KZ, RU, TJ, TM), ヨーロッパ
(AL, AT, BE, BG, CH, CY, CZ, DE, DK, EE, ES, FI, FR,
GB, GR, HR, HU, IE, IS, IT, LT, LU, LV, MC, MK, MT,
NL, NO, PL, PT, RO, RS, SE, SI, SK, SM, TR), OAPI
- (30) 優先権データ:
特願 2013-077523 2013年4月3日(03.04.2013) JP
- (71) 出願人: JFEスチール株式会社 (JFE STEEL
CORPORATION) [JP/JP]; 〒1000011 東京都千代田
区内幸町二丁目2番3号 Tokyo (JP).
- (72) 発明者: 藤原 大樹 (FUJIWARA Daiki); 〒1000011
東京都千代田区内幸町二丁目2番3号 JFE
スチール株式会社 知的財産部内 Tokyo (JP). 村
尾 明紀 (MURAO Akinori); 〒1000011 東京都千代
田区内幸町二丁目2番3号 JFEスチール株
式会社 知的財産部内 Tokyo (JP). 加治佐 健
(KAJISA Takeshi); 〒1000011 東京都千代田区内幸
町二丁目2番3号 JFEスチール株式会社
知的財産部内 Tokyo (JP). ▲徳▲留 三士 (TOK-
UDOME Mitsushi); 〒1000011 東京都千代田区内幸

[続葉有]

(54) Title: BLAST FURNACE OPERATION METHOD AND LANCE

(54) 発明の名称: 高炉操業方法及びランス

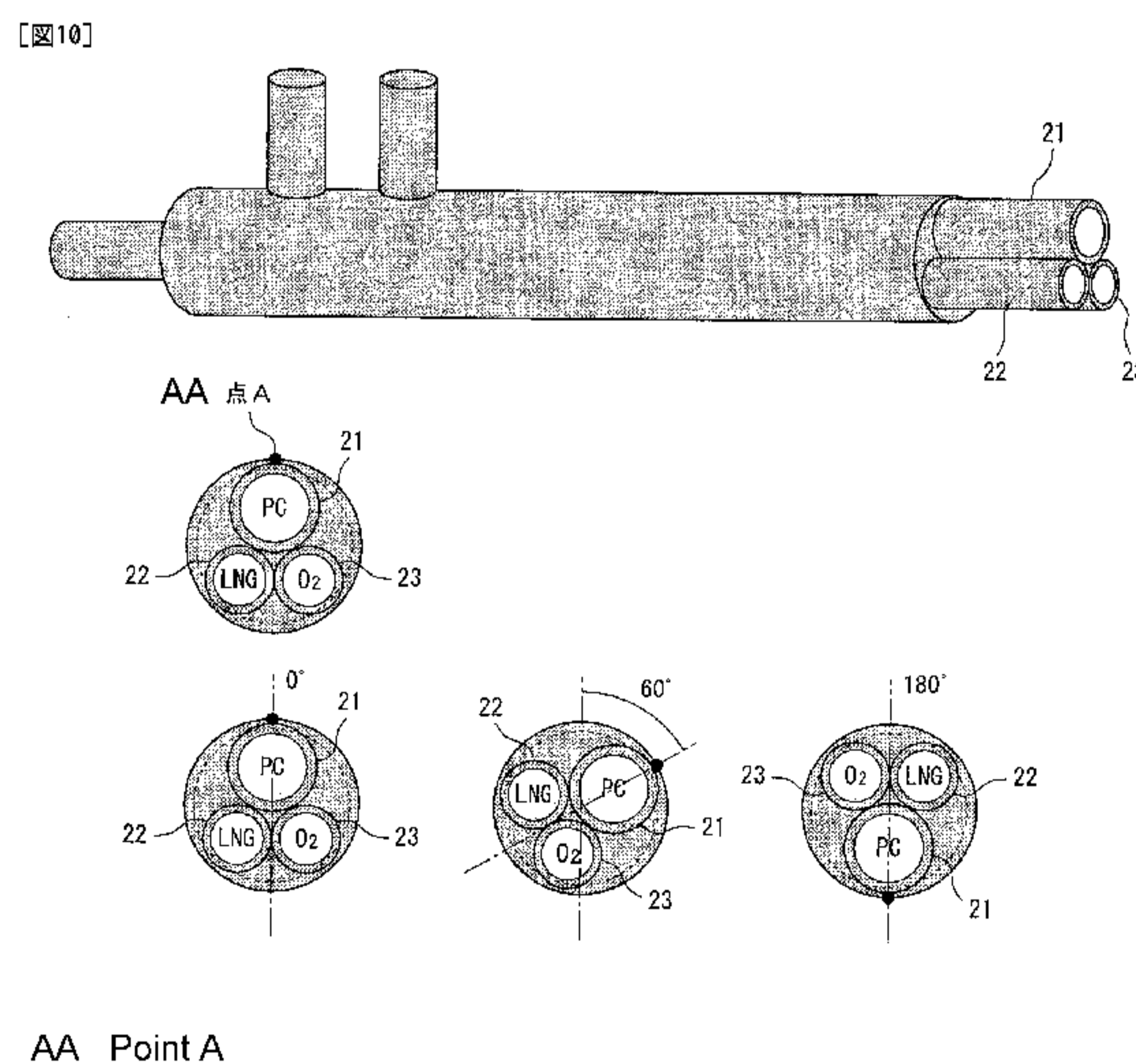

(57) Abstract: [Problem] To provide a blast furnace operation method and a lance making it possible to improve cooling power, improve the combustion quality of pulverized coal blown in from a tuyere, and reduce the unit consumption of the reducing agent. [Solution] A blast furnace operation method in which a solid reducing agent, a flammable gaseous reducing agent, and a combustion-sustaining gas are blown from a tuyere into the furnace through a lance, wherein: a parallel-type lance in which three independent blowing tubes are bundled in parallel and integrated with an outer tube is used; the gaseous reducing agent and/or the combustion-sustaining gas, and the solid reducing agent, are simultaneously blown in through the respective blowing tubes; and the blowing-in from the parallel-type lance is performed in an orientation in which the solid reducing agent blowing tube and the gaseous reducing agent blowing tube are positioned above the combustion-sustaining gas blowing tube. In addition, a lance structure used in the blast furnace operation method.

(57) 要約:

[続葉有]



WO 2014/162965 A1

WO 2014/162965 A1 

(BF, BJ, CF, CG, CI, CM, GA, GN, GQ, GW, KM, ML, MR, NE, SN, TD, TG).

添付公開書類:
— 国際調査報告 (条約第 21 条(3))

【課題】羽口から吹き込まれる微粉炭の燃焼性の向上と冷却能の向上及び還元材原単位の低減を可能とする高炉操業方法及びランスを提供する。 【解決手段】羽口から高炉内に固体還元材、易燃性の気体還元材及び支燃性ガスをランスを介して吹き込む高炉操業方法において、独立した3個の吹き込み管が並列かつ束ねられて外管と共に一体化した並列型ランスを用い、それぞれの吹き込み管から、気体還元材及び支燃性ガスのいずれか1又は2と固体還元材とを同時に吹き込むと共に、該並列型ランスからの吹き込みに際し、固体還元材用吹き込み管及び気体還元材用吹き込み管が支燃性ガス吹き込み管よりも上方に位置する姿勢にして行なう高炉操業方法と、そのランス構造。

SPECIFICATION

TITLE: Blast furnace operation method and lance

5 TECHNICAL FIELD

[0001] This invention relates to a blast furnace operation method effective for the improvement of productivity and the reduction of specific consumption of a reducing material by blowing a flammable gaseous reducing material such as LNG (liquefied natural gas) or a combustible gas together with a solid reducing material such as pulverized coal or the like into the furnace through tuyeres to raise combustion temperature at tips of the tuyeres as well as a lance used in the operation of this method.

RELATED ART

[0002] Recently, global warming comes into problem with the increase of carbon dioxide emissions, and the suppression of CO₂ discharged becomes an important issue in the iron industry. As to such an issue, the operation with a low reduction agent ratio (abbreviated as low RAR, total amount of a reducing material blown through tuyeres and coke charged from a top of the furnace per 1 ton of pig iron) is driven forward in the recent blast furnace operations. Since coke and pulverized coal are mainly used as a reducing material in the blast furnace, in order to attain the low reduction agent ratio and hence the suppression of carbon dioxide emissions, it is effective to replace coke or the like with a reducing material having a high hydrogen content ratio such as waste plastic, LNG, heavy oil or the like.

[0003] Patent Document 1 discloses a technique wherein a solid reducing material, a gaseous reducing material and a combustible gas are simultaneously blown with a plurality of lances to promote the heating of the solid reducing material in a combustion field of the gaseous reducing material. In this technique, it is said that the combustion rate of the solid reducing material can be improved to suppress the generation of unburned powder or coke breeze to thereby improve the air permeability and decrease the reduction agent ratio. Patent Document 2 discloses a technique wherein a lance is multiple-tube type

and, for example, a solid reducing material is blown through an inner tube and a combustible gas is blown from a gap between inner tube and middle tube and a gaseous reducing material is blown from a gap between middle tube and outer tube. Further, Patent Document 3 discloses that a plurality of small-size tubes
5 are arranged around a main tube of the lance in parallel.

PRIOR ART DOCUMENTS

PATENT DOCUMENTS

[0004] Patent Document 1: JP-A-2007-162038

Patent Document 2: JP-A-2003-286511

10 Patent Document 3: JP-A-H11-12613

SUMMARY OF THE INVENTION

TASK TO BE SOLVED BY THE INVENTION

[0005] The blast furnace operation method disclosed in Patent Document 1 has an effect of raising the combustion temperature at the tip of the tuyere and
15 reducing the specific consumption of the reducing material as compared to the method of blowing only the pulverized coal through the tuyere, but the effect is insufficient in only the adjustment of blowing positions. In the multiple-tube type lance disclosed in Patent Document 2, it is necessary to increase an outer blowing rate for ensuring the cooling ability of the lance. To this end, the gap
20 between inner tube and outer tube should be made extremely narrow, which cannot flow the predetermined gas amount in view of the restriction of equipment and has a fear of obtaining no effect of improving the combustibility. If it is intended to establish the gas amount and the flow rate, the diameter of the lance becomes extremely large to bring about the decrease of blast volume in a
25 blowpipe (blast tube), and hence an amount of molten iron tapped is decreased or the risk of breaking the surrounding refractories is increased associated with the increase of the diameter in the insert port of the lance. In the lance disclosed in Patent Document 3 are arranged a plurality of small-size blowing tubes, so that there are problems that not only a risk of clogging the blowing tube is enhanced
30 due to the decrease of the cooling ability but also the precess cost of the lance is increased. Furthermore, the multiple-tube structure is changed into a parallel-tube structure on the way thereof, so that there is a problem that the

pressure loss and the diameter become large.

[0006] It is an object of the invention to propose a blast furnace operation method capable of overcoming the aforementioned problems inherent to the conventional techniques as well as a lance used in the operation of this method.

5 Especially, it is to propose a blast furnace operation method capable of attaining the enhancement of cooling ability and the improvement of combustibility and the reduction of specific consumption of a reducing material without making the diameter of the lance extremely large.

SOLUTION FOR TASK

10 **[0007]** The invention is developed for solving the above tasks and is a method of operating a blast furnace by blowing a solid reducing material, a gaseous reducing material and a combustible gas into a blast furnace from tuyeres through a lance, characterized in that a parallel type lance prepared by bundling
15 three independent blowing tubes in parallel and integrally housing them into an outer tube for the lance is used, and either one or both of the gaseous reducing material and the combustible gas and the solid reducing material are simultaneously blown through the respective blowing tubes, while the blowing
20 tube for the solid reducing material and the blowing tube for the gaseous reducing material are positioned above the blowing tube for the combustible gas in the blowing through the parallel type lance.

[0008] Also, the invention is a lance for blowing a solid reducing material, a gaseous reducing material and a combustible gas through tuyeres into a blast furnace, characterized by having a structure that three independent blowing tubes are bundled in parallel and integrally housed in an outer tube for lance when
25 either one or both of the gaseous reducing material and the combustible gas are simultaneously blown together with the solid reducing material, and disposing the respective blowing tubes so as to satisfy a position relation that the blowing tube for the solid reducing material and the blowing tube for the gaseous reducing material are positioned above the blowing tube for the combustible gas.

30 **[0009]** In the invention are provided the followings as a preferable means:

(1) the blowing tube for solid reducing material, the blowing tube for gaseous reducing material and the blowing tube for combustible gas in the

parallel type lance are arranged so that an angle of a face passing an outer contact point between a center of the blowing tube for solid reducing material and the outer tube for lance to a radially vertical face of the lance inserted into a blowpipe is within $\pm 90^\circ$; and

- 5 (2) each of the blowing tubes is a tube having an inner diameter of not less than 6 mm but not more than 30 mm.

EFFECT OF THE INVENTION

[0010] According to the invention, the parallel type lance prepared by bundling the respective blowing pathways in parallel and integrally housing into the outer tube for lance is used when the solid reducing material, flammable
10 gaseous reducing material and combustible gas are simultaneously blown into the blast furnace, whereby the pathway of the blowing tube can be made large without increasing the outer diameter of the lance. According to the invention, therefore, it can be attempted to establish the increase of the cooling ability and
15 the improvement of the combustibility, and hence the decrease of the specific consumption of the reducing material can be attained in the operation of the blast furnace.

BRIEF DESCRIPTION OF THE DRAWINGS

[0011] FIG. 1 is a longitudinal section view illustrating an example of the
20 blast furnace.

FIG. 2 is a view explaining a combustion state when only pulverized coal is blown through a lance.

FIG. 3 is a view explaining a combustion mechanism of pulverized coal.

25 FIG. 4 is a view explaining a combustion mechanism when LNG and oxygen are blown together with pulverized coal.

FIG. 5 is an explanatory diagram illustrating an arrangement of blowing tubes in a lance (outer tube).

FIG. 6 is a graph showing pressure loss in combustion experiments.

30 FIG. 7 is a graph showing a lance surface temperature in combustion experiments.

FIG. 8 is an explanatory diagram of an outer diameter in a lance.

FIG. 9 is a schematic view of an apparatus for combustion experiment.

FIG. 10 is a view explaining an arrangement of each blowing tube in a lance.

5 FIG. 11 is a graph showing a change of combustion temperature in combustion experiments.

EMBODIMENTS FOR CARRYING OUT THE INVENTION

[0012] The blast furnace operation method according to the invention and the lance used in this operation will be described with reference to the accompanying
10 drawings below. FIG. 1 is a schematic view of a blast furnace applied to the blast furnace operation method according to the invention. As shown in this figure, the blast furnace 1 is provided with plural tuyeres in its peripheral direction. To the tuyere 3 is connected a blowpipe (blast pipe) 2 for blowing hot
15 air, and the blowpipe 2 is provided with a lance 4 inserted obliquely mainly from above toward a center of an axial direction of the blowpipe. Forward a blowing direction of hot air from the tuyere 3 (inside the furnace) is formed a combustion space called as a raceway 5 being also a coke deposit layer, and reduction of iron
ore is mainly performed in the combustion space to produce a molten iron.

[0013] FIG. 2 shows a combustion state when only a pulverized coal 6 is
20 blown from the lance 4. The pulverized coal 6 is blown from the lance 4 through the tuyere 3 into the raceway 5 and lumpy coke 7 is charged from the top of the furnace and deposited in the raceway 5, where volatile matter and fixed carbon thereof are combusted. An aggregate of unburned residual carbon and ash, which is generally called as a char, is dispersed from the raceway 5 inside
25 the furnace as an unburned char 8. A blowing rate of hot air forward the blowing direction of hot air blown from the tuyere 3 into the furnace is about 200 m/sec and an O₂ existing region from the front end of the lance 4 into the raceway 5 is about 0.3-0.5 m. Therefore, the heating of pulverized coal particles and the contact efficiency (dispersibility) with oxygen (O₂) as a combustible gas are
30 necessary to be improved substantially in a level of 1/1000 second.

[0014] FIG. 3 is an explanatory view of a combustion mechanism when only the pulverized coal (PC) 6 as a solid reducing material is blown from the lance 4

into the blowpipe 2. The particles of the pulverized coal 6 blown from the tuyere 3 into the raceway 5 are heated by radiant heat transfer from the flame in the raceway 5 and further the temperature of the particles is violently raised by radiant heat transfer and conduction transfer. Thermal decomposition is started from a time of heating to not less than 300°C and volatile matter is ignited to form flame and the combustion temperature (particle temperature) reaches 1400-1700°C. After the volatile matter is discharged, the aforementioned char 8 is formed. Since the char 8 is composed mainly of fixed carbon, carbon dissolving reaction is caused together with the combustion reaction.

10 [0015] FIG. 4 is an explanatory view of a combustion mechanism when LNG as a preferable example of the flammable gaseous reducing material and oxygen as a preferable example of the combustible gas (not shown) are blown together with the pulverized coal 6 from the lance 4 into the blowing pipe 2. This figure is a case of simultaneously blowing the pulverized coal, LNG and oxygen simply. 15 Moreover, a dashed line in the figure shows a combustion (particle) temperature in the blowing of only the pulverized coal shown in FIG. 3 as reference. When the pulverized coal and LNG and oxygen are simultaneously blown as mentioned above, it is considered that the pulverized coal is dispersed associated with the diffusion of gas, and LNG is combusted by the contact with oxygen, and the 20 pulverized coal is rapidly heated by the combustion heat. In this case, therefore, the combustion of the pulverized coal is performed in a position near to the lance. As the position of starting the combustion becomes near to the lance, a chance of damaging the lance becomes higher, so that it is necessary to enhance the durability of the lance or a cooling ability.

25 [0016] FIG. 5a shows a general multiple-tube type lance conventionally used. FIG. 5b shows a parallel type lance proposed in the invention. The multiple-tube type lance is a coaxially triple tube of an inner tube I, a middle tube M and an outer tube O made of stainless steel tube, and dimensions of the respective tubes are shown in the figure. Moreover, a gap between the inner 30 tube I and the middle tube M is 1.15 mm, and a gap between the middle tube M and the outer tube O is 0.65 mm.

[0017] In the parallel type lance according to the invention, a blowing tube

21 for solid reducing material, a blowing tube 22 for gaseous reducing material and a blowing tube 23 for combustible gas such as oxygen or the like are bundled in parallel and integrally housed in an outer tube for lance, and the dimensions of the respective tubes are shown in the figure.

5 [0018] In FIG. 6 are shown results of comparative measurement on pressure loss of the multiple-tube type lance and the parallel type lance. As seen from this figure, the pressure loss is less in the parallel type lance as compared to the multiple-tube type lance under the same pathway. This is considered due to the fact that the blowing space (volume in the blowing tube) is made relatively
10 large to decrease airflow resistance in the case of the parallel type lance.

[0019] FIG. 7 shows a comparison chart of cooling ability between the lances (multiple-tube type and parallel type). As seen from this figure, the cooling ability under the same pressure loss is higher in the parallel type lance than in the multiple-tube type lance. This is considered due to the fact that the flow rate
15 capable of flowing under the same pressure loss is large because the airflow resistance in the tube is small.

[0020] In FIG. 8 is noticed an outer diameter of a lance. FIG. 8a shows an outer diameter of a non-water cooling type lance, and FIG. 8b shows an outer diameter of a water cooling type lance. As seen from this figure, the outer
20 diameter of the lance is small in the parallel type lance as compared to the multiple-tube type lance. This is considered due to the fact that the parallel type lance can decrease the pathway, tube thickness and sectional area of water cooling portion as compared to the multiple-tube type lance.

[0021] In order to compare the combustibility between the parallel type lance and the multiple-tube type lance, combustion experiment is performed with an
25 apparatus for combustion experiment shown in FIG. 9. In an experimental furnace 11 are filled lumpy cokes, and an interior of a raceway 15 can be observed through an inspection window. A lance 14 is inserted into a blowpipe (blast pipe) 12, whereby hot air produced by a combustion burner 13 can be
30 blown into the experimental furnace 11 at a given blowing rate. In the blast pipe 12, it is also possible to adjust an oxygen enriched amount during the air blowing. The lance 14 can blow the pulverized coal and either one or both of LNG and

oxygen into the blast pipe 12. An exhaust gas produced in the experimental furnace 11 is separated into an exhaust gas and dust by a separating device 16 called as a cyclone, in which the exhaust gas is supplied to an equipment for treating the exhaust gas such as auxiliary combustion furnace or the like, and the dust is collected in a collection box 17.

[0022] [Combustion Experiment]

As a lance 14 are used a single tube lance, a triple tube lance (which is also called as multiple-tube type lance hereinafter) and a parallel type lance prepared by bundling three blowing tubes in parallel and integrally housing them in this combustion experiment. Based on a case that only the pulverized coal is blown through the single tube lance, the pulverized coal is blown through the inner tube and oxygen is blown from a gap between the inner tube and the middle tube and LNG is blown from a gap between the middle tube and the outer tube in the multiple-tube type lance. In the parallel type lance, the pulverized coal, LNG and oxygen are blown through the bundled independent blowing tubes. As to a case that blowing positions are changed around the axis of the lance are measured combustion temperature with a two-color thermometer, pressure loss in the lance, lance surface temperature and outer diameter of a lance. As is well-known, the two-color thermometer is a radiation thermometer for measuring temperature by utilizing heat radiation (movement of electromagnetic wave from high-temperature object to low-temperature object). Noting that wave distribution shifts toward a short wave side as the temperature becomes higher, it is one of wave distribution forms for determining the temperature by measuring the change of temperature in the wave distribution. Especially, radiation energies at two waves are measured for grasping the wave distribution, and the temperature is determined from a ratio thereof.

[0023] In this experiment, the pulverized coal (PC) is blown from the blowing tube 21 for solid reducing material and LNG is blown from the blowing tube 22 for gaseous reducing material and oxygen is blown from the blowing tube 23 for combustible gas as shown in FIG. 10. In the case of using a lance prepared by bundling three independent blowing tubes in parallel and integrally housing them into an outer tube for lance, the blowing through the parallel type

lance is performed so that the blowing tube for the solid reducing material and the blowing tube for the gaseous reducing material are positioned above the blowing tube for the combustible gas. That is, the position relation of pulverized coal, LNG and oxygen blown into the blowpipe is a relation that oxygen is blown beneath an axial center of the blowpipe and the pulverized coal and LNG are blown above.

[0024] Such a position relation means that the blowing through the parallel type lance is performed by such an arrangement of a lance that an angle of a face passing an outer contact point between a center of the blowing tube for solid reducing material and the lance to a radially vertical plane of the lance inserted into a blowpipe is within $\pm 90^\circ$ or an arrangement relation of each of the blowing tubes. Namely, when a position corresponding to an outer diameter of the lance on an outer peripheral surface of the blowing tube 21 for pulverized coal is a point A, combustion temperature is measured by the two-color thermometer at a position of 0° that the point A lies in an uppermost part, a position clockwise rotating the point A by 60° around the axial line of the lance and a position rotating the point A by 180° , respectively. Moreover, the insert length of the lance into the blowpipe is 50 mm.

[0025] The pulverized coal as a solid reducing material has a fixed carbon (FC) content of 71.3%, a volatile matter (VM) content of 19.6% and an ash content (Ash) of 9.1% and the blowing condition thereof is 50.0 kg/h (corresponding to 158 kg/t as a specific consumption of molten iron). The blowing condition of LNG is 3.6 kg/h ($5.0 \text{ Nm}^3/\text{h}$, corresponding to 11 kg/t as a specific consumption of molten iron). The coke is used to satisfy $^{150}_{15}\text{D183}$ by a test method described in JIS K2151. Blast condition is that a blast temperature of 1100°C , a flow amount of $350 \text{ Nm}^3/\text{h}$, a flow rate of 80 m/s and O_2 enrichment + 3.7 (oxygen concentration: 24.7%, enriched to 3.7% with respect to oxygen concentration in air of 21%).

[0026] FIG. 11 shows results of combustion temperature in the combustion experiment. As seen from this figure, when the position of the first tube in the parallel type lance or the pulverized coal blowing tube is changed to 0° , 60° and 180° around the axial line of the lance, the combustion temperature becomes

highest at 60° or at a position that the blowing tubes for pulverized coal and LNG are above the oxygen blowing tube. This is considered due to the fact that the combustion field of LNG is made adjacent to the pulverized coal to heat the pulverized coal and oxygen is positioned beneath LNG and pulverized coal to efficiently mix with both LNG and pulverized coal and hence the combustion is promoted.

[0027] In the blast furnace operation method adapted to the embodiment of the invention, when the pulverized coal (solid reducing material) 6, LNG (flammable gaseous reducing material) 9 and oxygen (combustible gas) are simultaneously blown through the lance 4 into the tuyere 3, the blowing area of the blowing tube (gap) can be largely maintained without making the outer diameter of the lance extremely large by using the parallel type lance prepared by bundling the respective blowing tubes in parallel and integrally housing them into the outer tube for lance. According to the invention method and lance, therefore, it can be attained to establish the increase of the cooling ability and the improvement of the combustibility, and hence the specific consumption of the reducing material can be decreased.

[0028] Although the above embodiment is described by using LNG as a flammable gaseous reducing material, it is possible to use a town gas. In addition to the town gas and LNG, propane gas, hydrogen as well as converter gas, blast furnace gas and coke-oven gas produced in the the iron foundry can be used as the other gaseous reducing material. Moreover, shale gas may be utilized in equivalence to LNG. The shale gas is a natural gas obtained from a shale stratum, which is called as a non-conventional natural gas resource because it is produced in a place different from the conventional gas field.

DESCRIPTION OF REFERENCE SYMBOLS

[0029] 1: blast furnace, 2: blowpipe, 3: tuyere, 4: lance, 5: raceway, 6: pulverized coal (solid reducing material), 7: coke, 8: char, 9: LNG (flammable gaseous reducing material)

CLAIMS

1. A method of operating a blast furnace by blowing a solid reducing material, a gaseous reducing material and a combustible gas into a blast furnace from tuyeres through a lance into a blast furnace, characterized in that a parallel type lance prepared by bundling three independent blowing tubes in parallel and integrally housing them into an outer tube for the lance is used, and either one or both of the gaseous reducing material and the combustible gas and the solid reducing material are simultaneously blown through the respective blowing tubes, while the blowing tube for the solid reducing material and the blowing tube for the gaseous reducing material are positioned above the blowing tube for the combustible gas in the blowing through the parallel type lance.

2. The method of operating a blast furnace according to claim 1, wherein the blowing tube for solid reducing material, the blowing tube for gaseous reducing material and the blowing tube for combustible gas in the parallel type lance are arranged so that an angle of a face passing an outer contact point between a center of the blowing tube for solid reducing material and the outer tube for lance to a radially vertical plane of the lance inserted into a blowpipe is within $\pm 90^\circ$.

3. A lance for blowing a solid reducing material, a gaseous reducing material and a combustible gas through tuyeres into a blast furnace, characterized by having a structure that three independent blowing tubes are bundled in parallel and integrally housed in an outer tube for lance when either one or both of the gaseous reducing material and the combustible gas are simultaneously blown together with the solid reducing material, and disposing the respective blowing tubes so as to satisfy a position relation that the blowing tube for the solid reducing material and the blowing tube for the gaseous reducing material are positioned above the blowing tube for the combustible gas.

4. A lance according to claim 3, wherein the blowing tubes are arranged so that an angle of a face passing an outer contact point between a center of the blowing tube for solid reducing material and the outer tube for lance to a radially vertical plane of the lance inserted into a blowpipe is within $\pm 90^\circ$.

5. A lance according to claim 3 or 4, wherein each of the blowing

tubes is a tube having an inner diameter of not less than 6 mm but not more than 30 mm.

FIG. 1

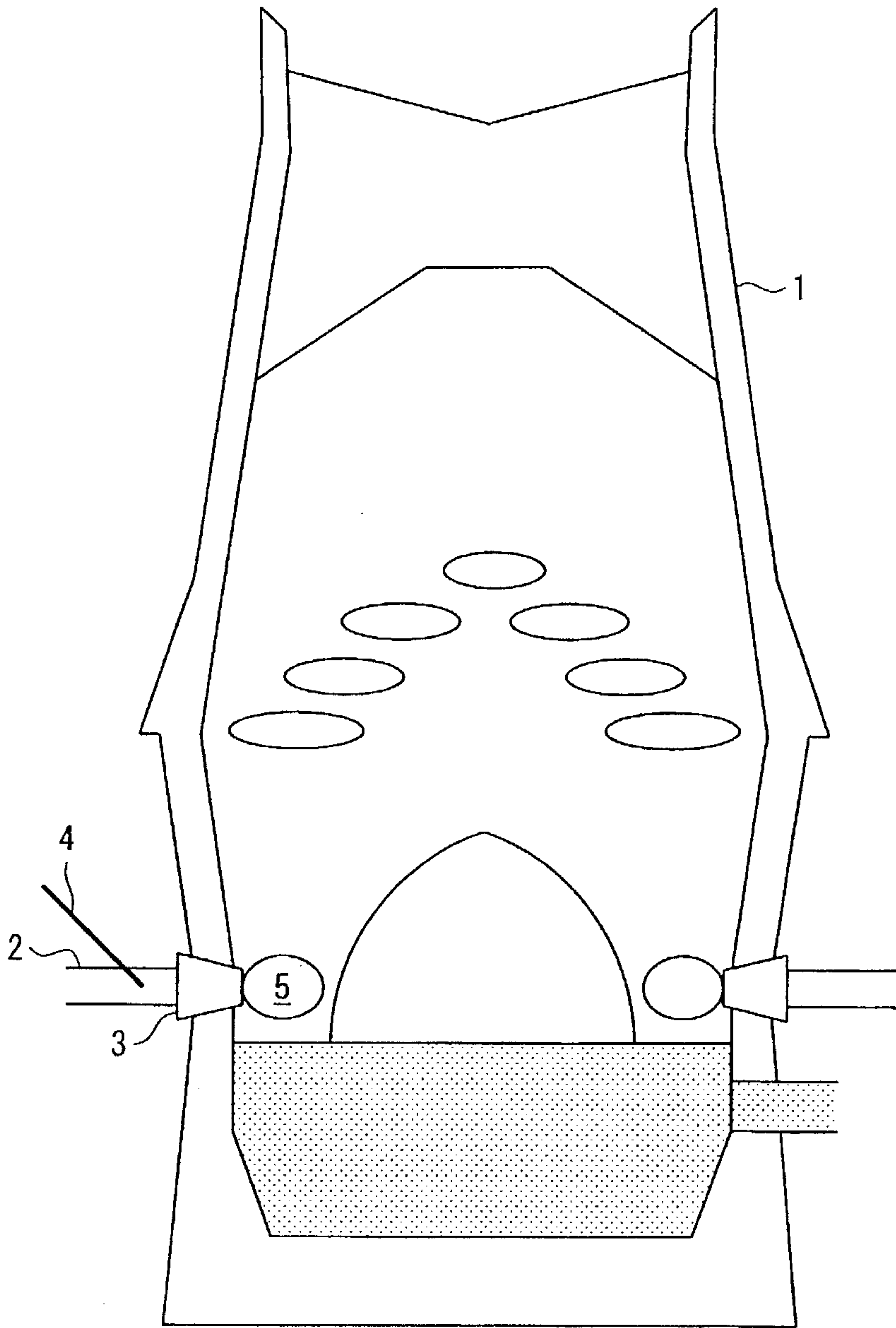

FIG. 2

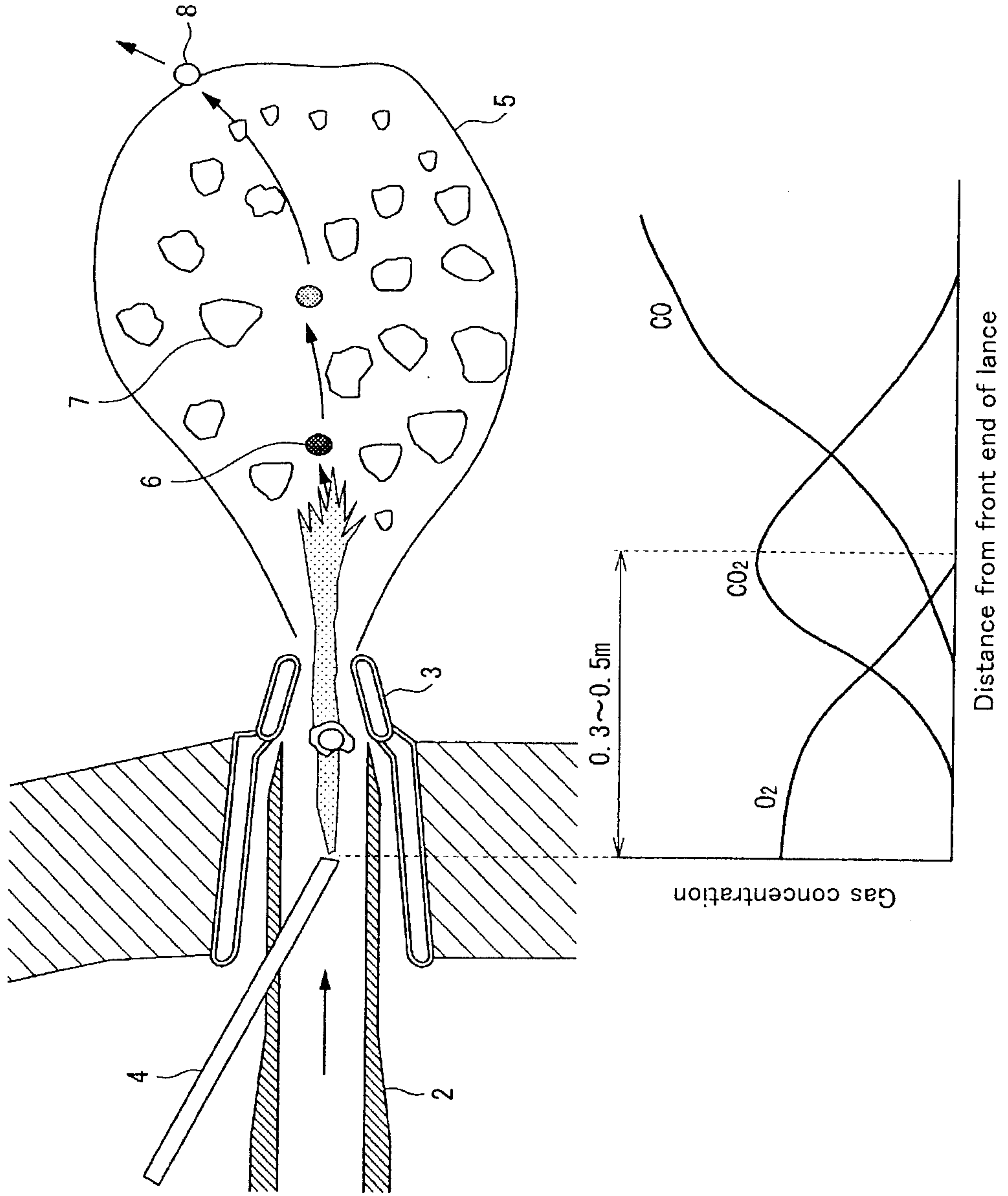

FIG. 3

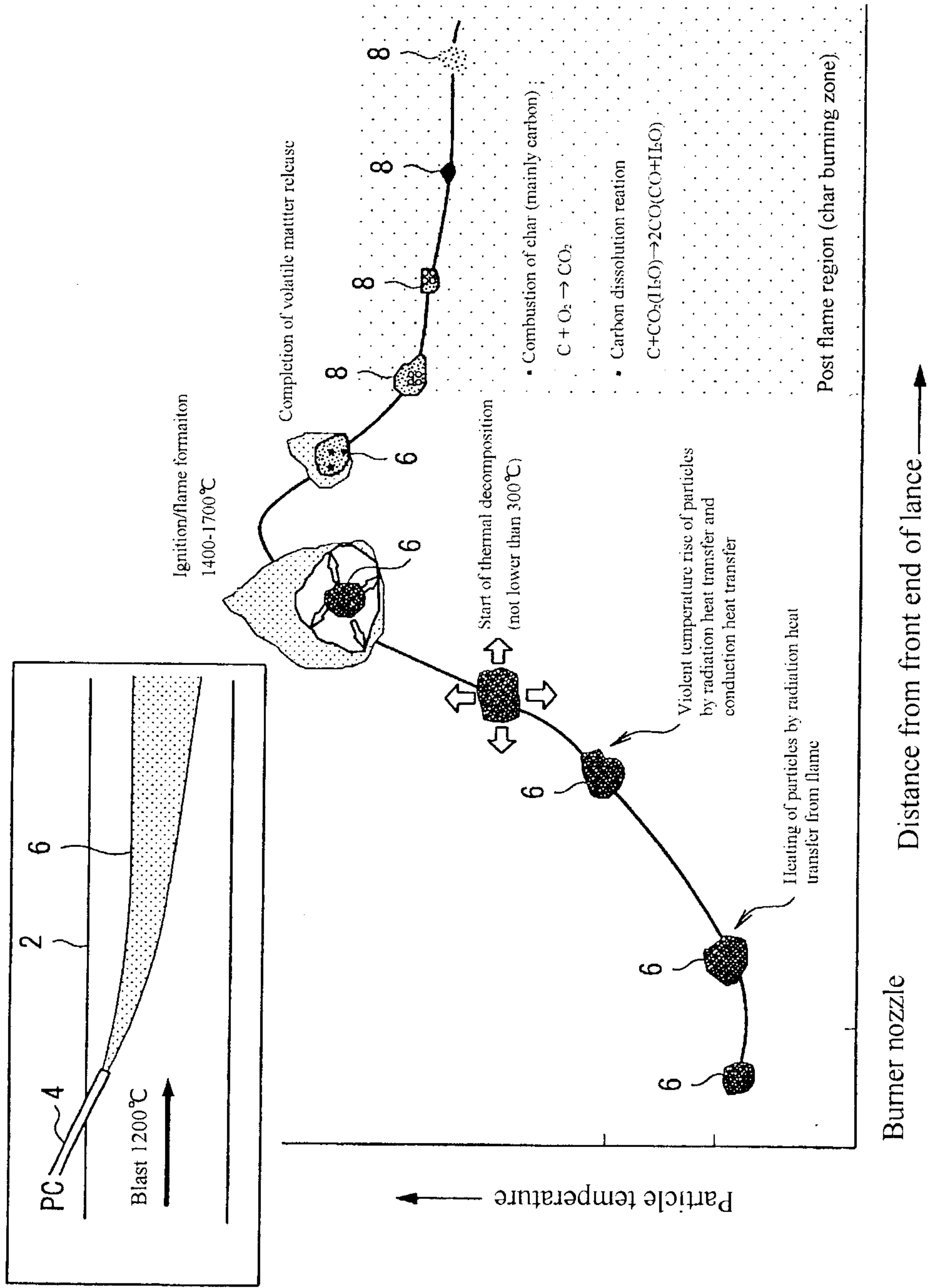

FIG. 4

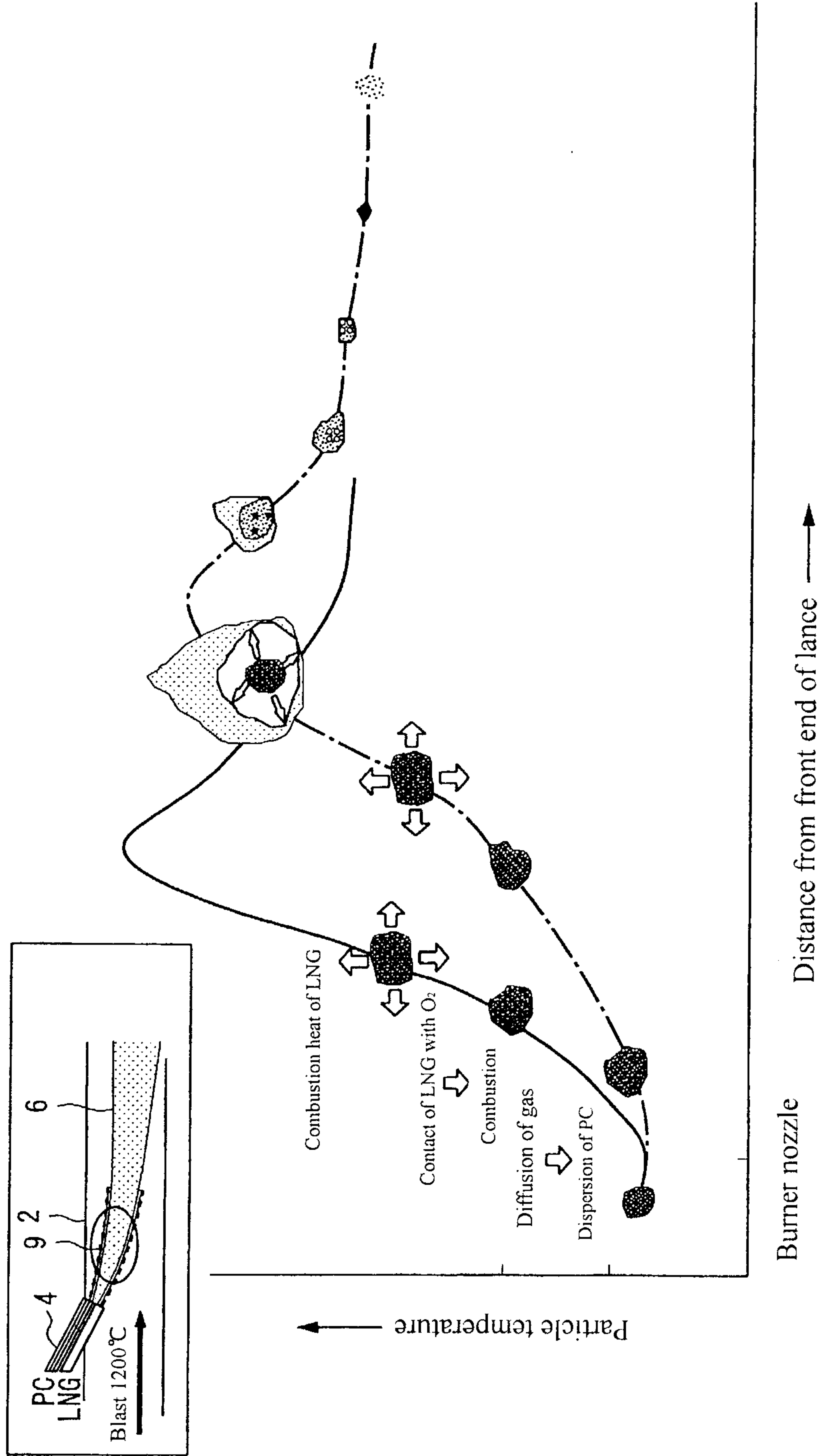

FIG. 5

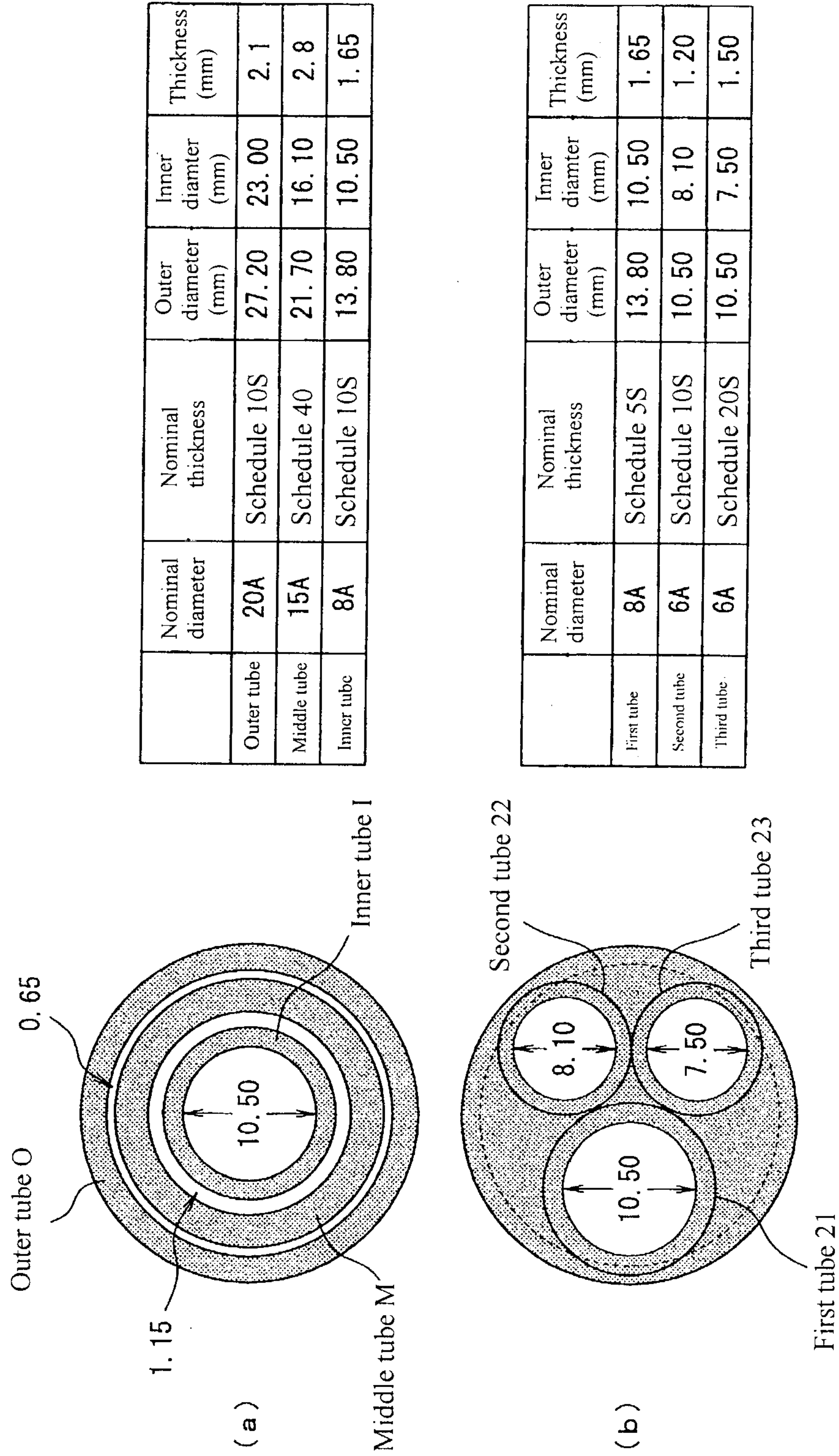
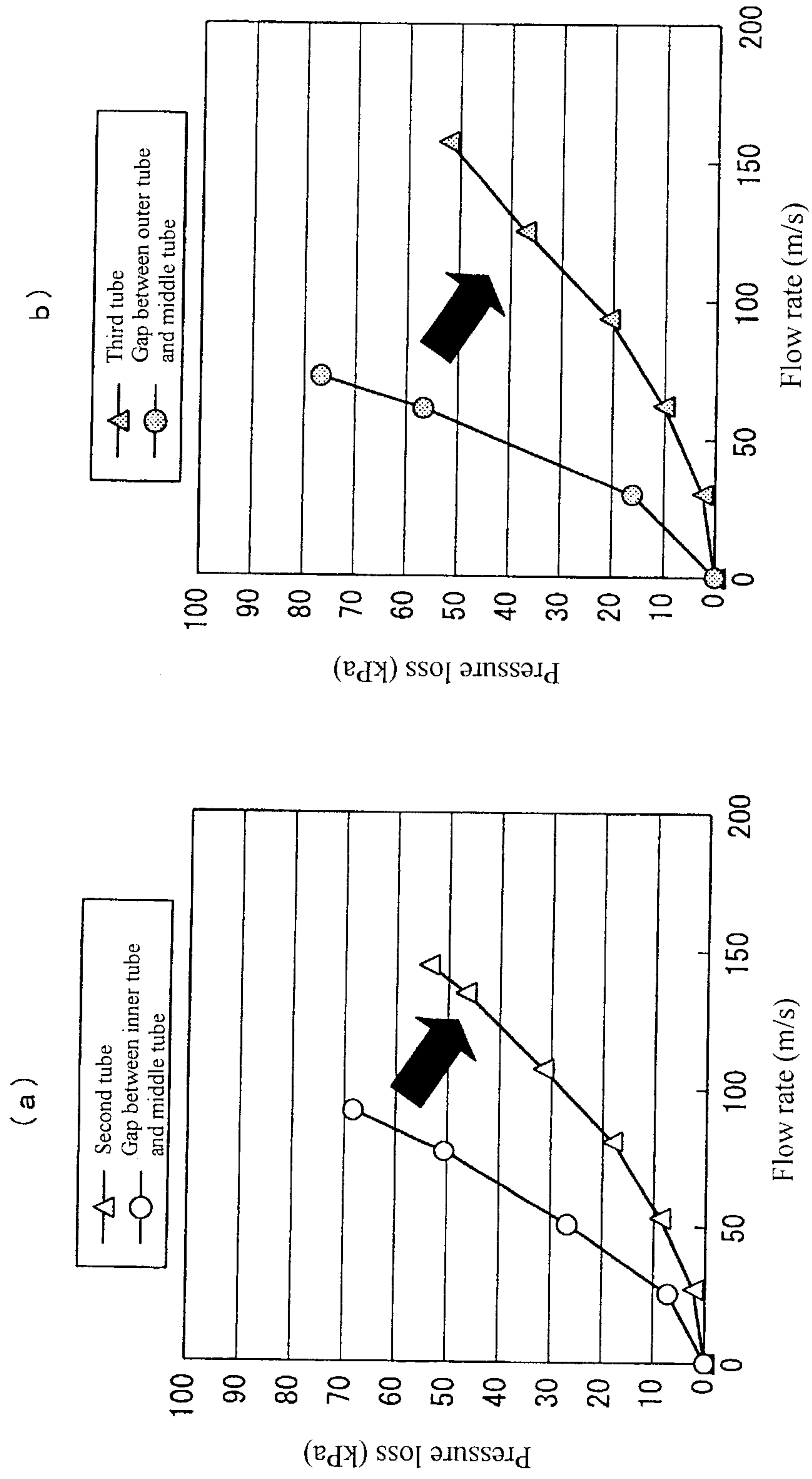

FIG. 6



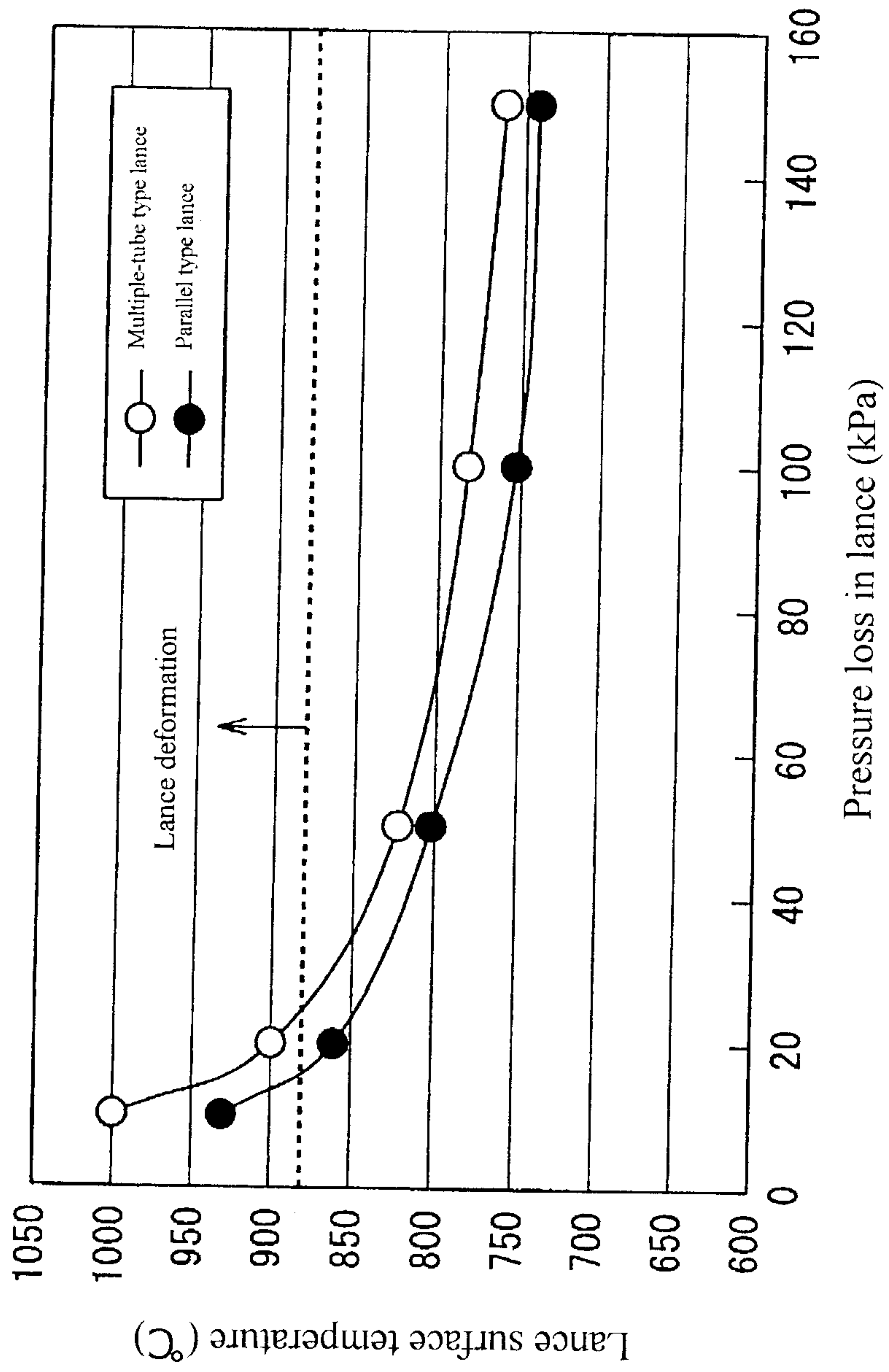
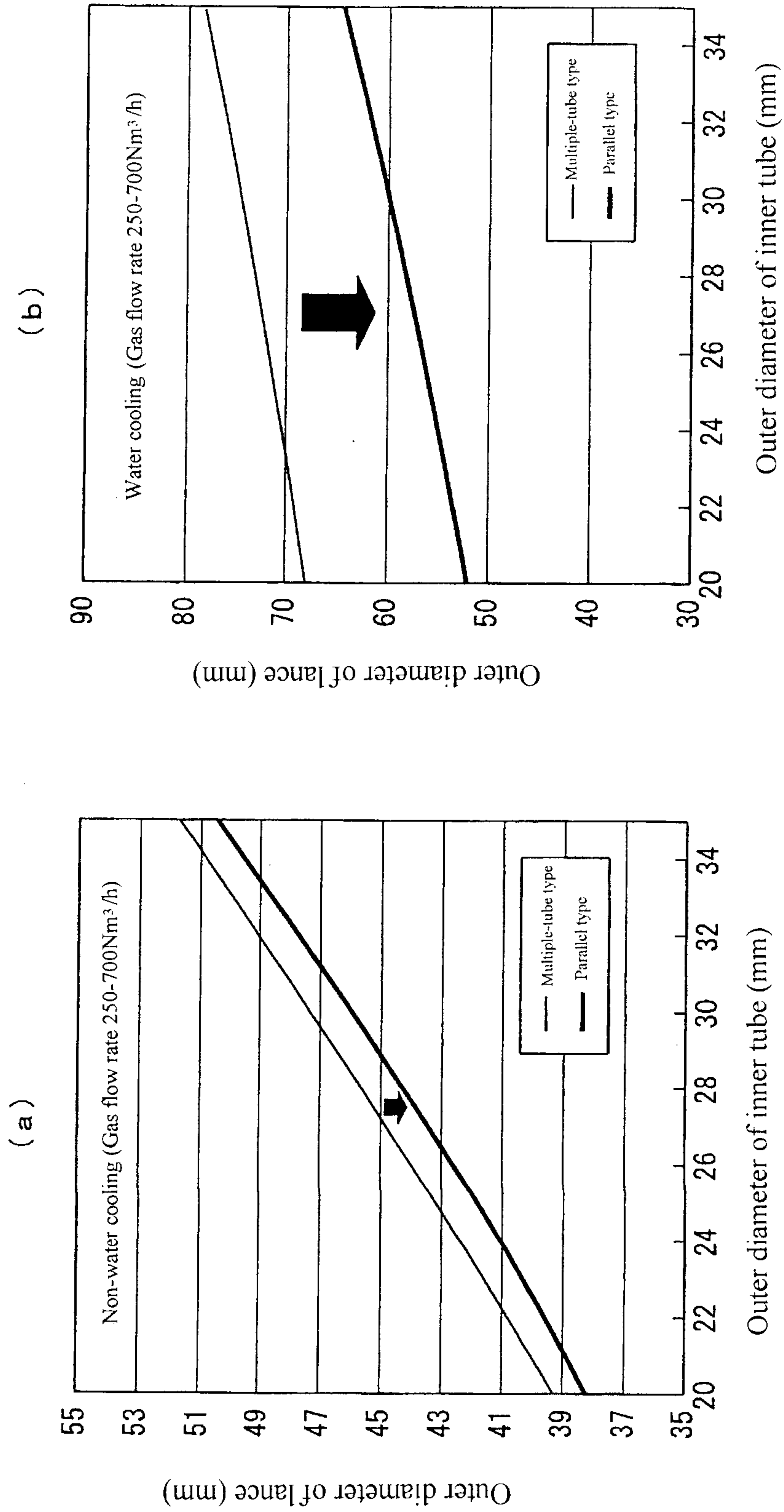

FIG. 7

FIG. 8



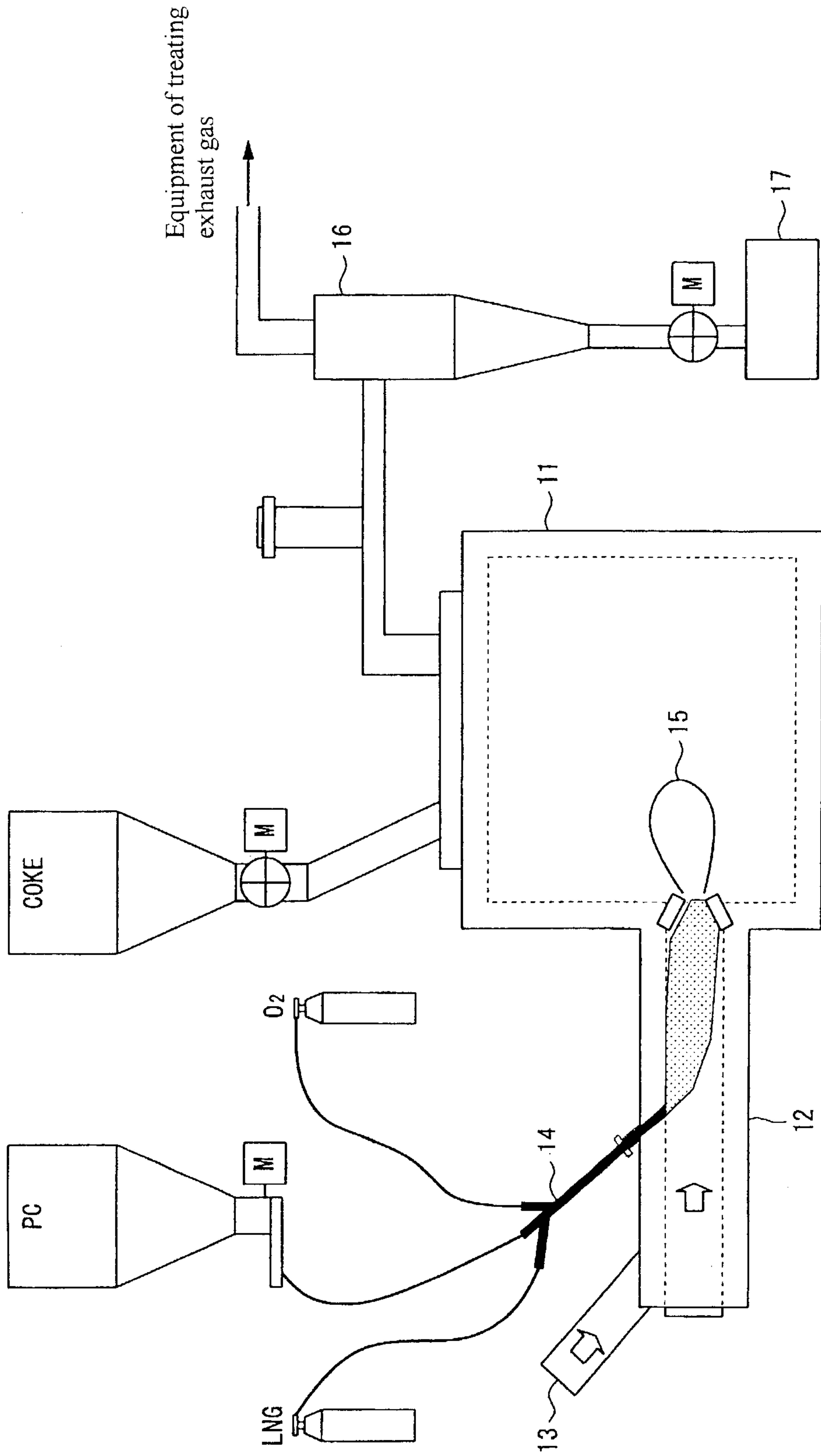
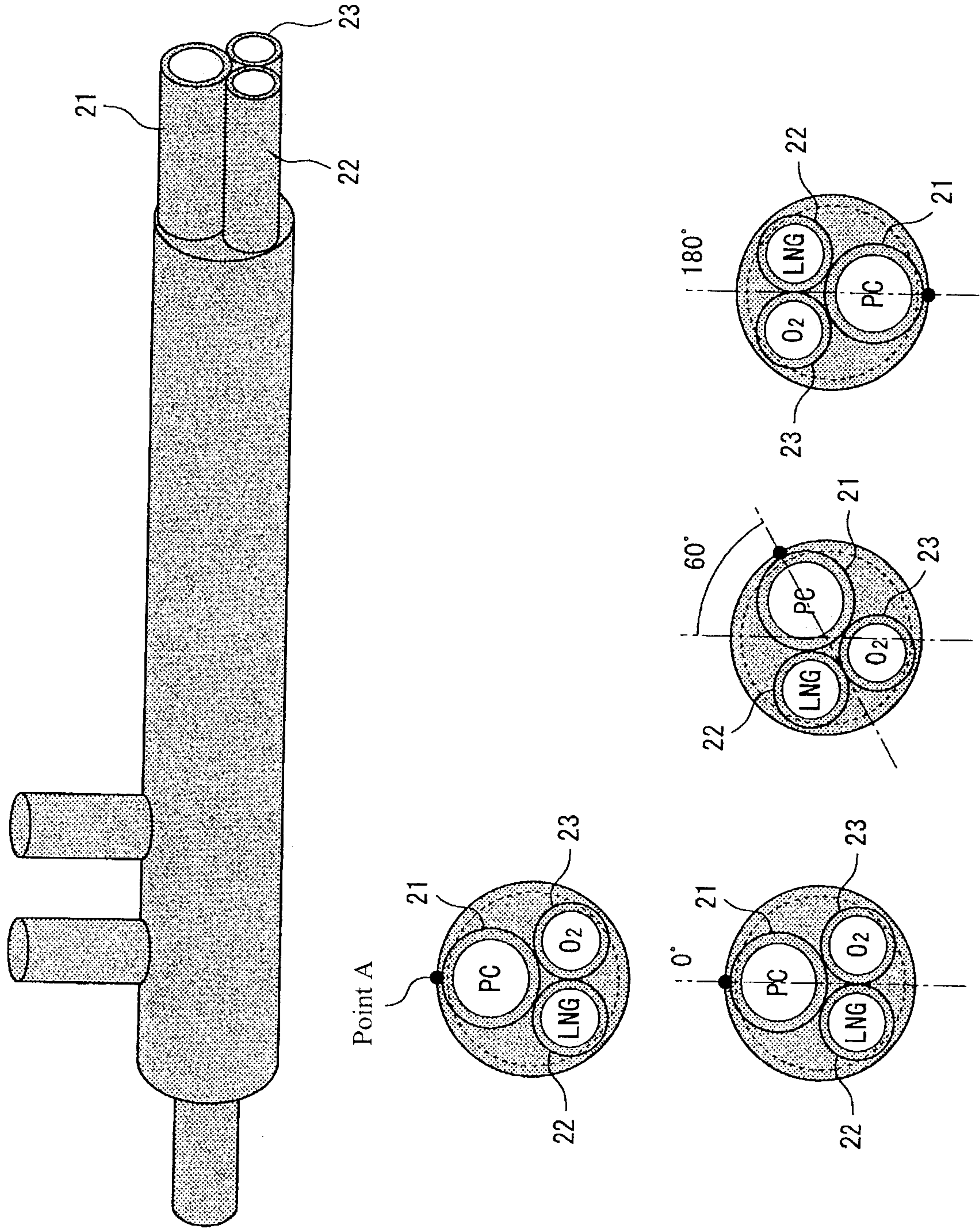

FIG. 9

FIG. 10



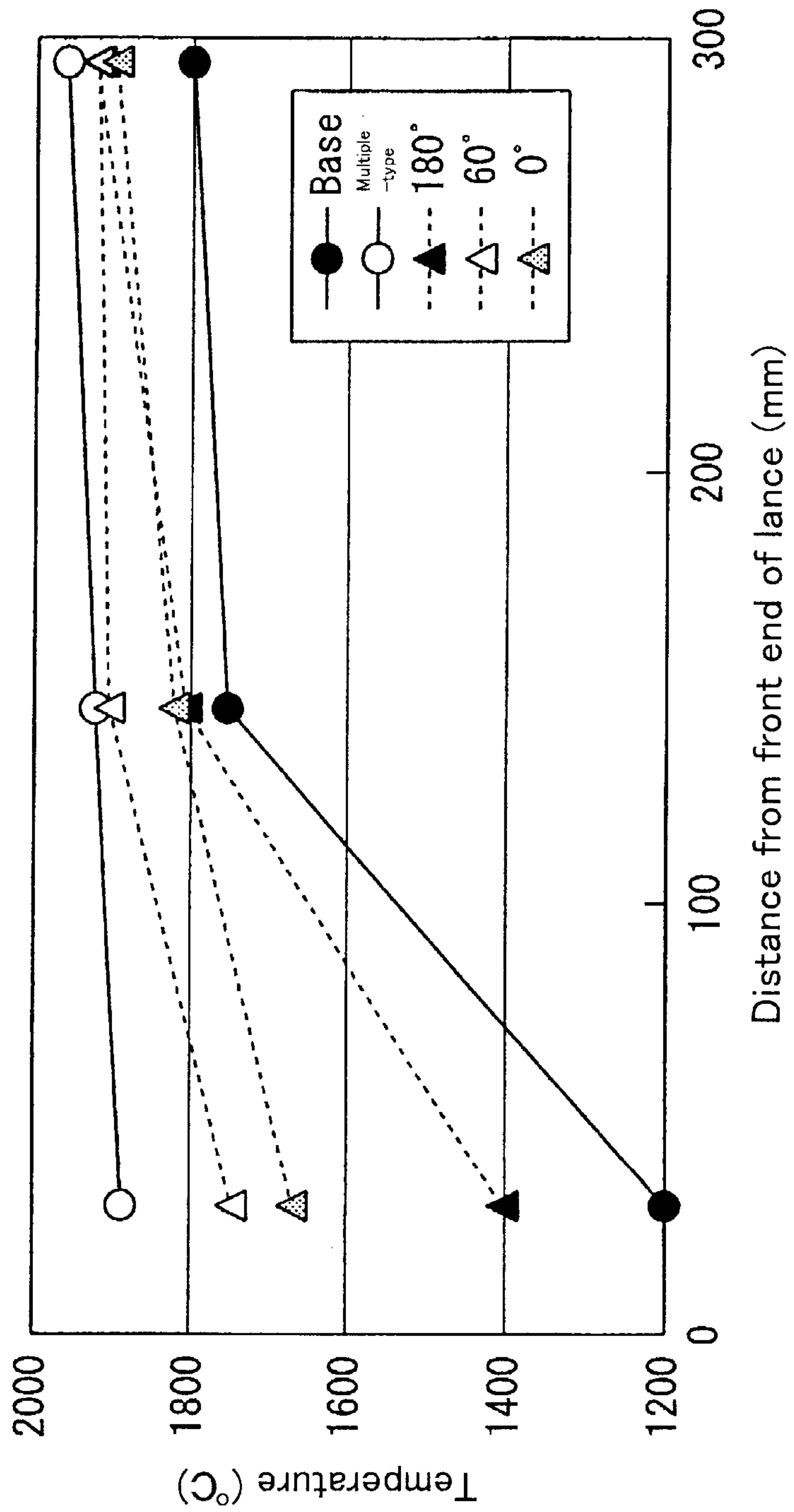

FIG. 11

