



(11) **EP 1 967 766 A3**

(12) **EUROPEAN PATENT APPLICATION**

(88) Date of publication A3:  
**08.10.2008 Bulletin 2008/41**

(51) Int Cl.:  
**F16H 55/48<sup>(2006.01)</sup> F16H 7/20<sup>(2006.01)</sup>**

(43) Date of publication A2:  
**10.09.2008 Bulletin 2008/37**

(21) Application number: **08004300.3**

(22) Date of filing: **07.03.2008**

(84) Designated Contracting States:  
**AT BE BG CH CY CZ DE DK EE ES FI FR GB GR HR HU IE IS IT LI LT LU LV MC MT NL NO PL PT RO SE SI SK TR**  
Designated Extension States:  
**AL BA MK RS**

(72) Inventors:  
• **Yanai, Kunio**  
**Osaka-shi**  
**Osaka 542-8502 (JP)**  
• **Hamada, Kazuki**  
**Osaka-shi**  
**Osaka 542-8502 (JP)**

(30) Priority: **07.03.2007 JP 2007056791**

(74) Representative: **Görz, Ingo**  
**Hofer & Partner**  
**Patentanwälte**  
**Pilgersheimer Strasse 20**  
**81543 München (DE)**

(71) Applicant: **JTEKT Corporation**  
**Osaka-shi**  
**Osaka 542-8502 (JP)**

(54) **Component comprising a ring-shaped metal member and a ring-shaped resin portion and manufacturing method thereof**

(57) A resin wound component is configured such that a ring-shaped resin portion (1) is integrally formed with the outer circumference of a ring-shaped metal member (21). At this time, stoppers (30) formed of ther-

moplastic resin are disposed in the outer circumferential surface of the metal member (21) so as to prevent a relative rotation between the metal member (21) and the resin portion (1).

**FIG. 1**

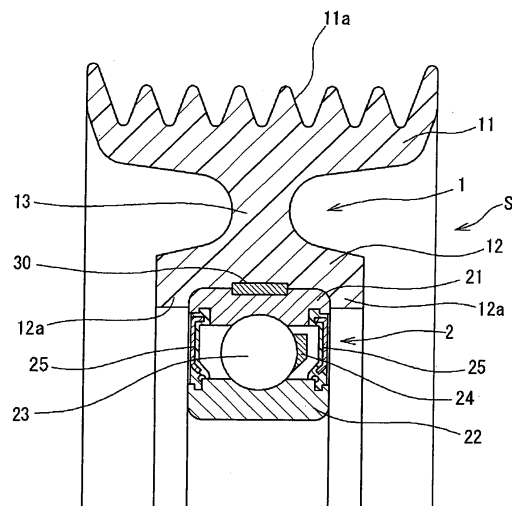

**EP 1 967 766 A3**



DOCUMENTS CONSIDERED TO BE RELEVANT			
Category	Citation of document with indication, where appropriate, of relevant passages	Relevant to claim	CLASSIFICATION OF THE APPLICATION (IPC)
X	JP 2005 220957 A (NSK LTD) 18 August 2005 (2005-08-18) * paragraphs [0001] - [0019] * * figures 1-18 *	1,4	INV. F16H55/48
X	JP 2004 286179 A (HIGH FREQUENCY HEATTREAT) 14 October 2004 (2004-10-14) * paragraphs [0018] - [0020] * * claims 1-7 * * figure 1 *	1,2	ADD. F16H7/20
X	US 3 990 136 A (HISHIDA TADASHI) 9 November 1976 (1976-11-09) * column 2, lines 5-31 * * claim 1 * * figures 1-3 *	1	
D,Y	JP 2004 162858 A (KOYO SEIKO CO) 10 June 2004 (2004-06-10) * abstract; figure 1 *	1-5	
Y	US 2 845 696 A (DE BOURGUES JACQUES) 5 August 1958 (1958-08-05) * column 2, line 47 - column 3, line 19 * * column 1, lines 14-37 * * claims 1,3 * * figures 4,5 *	1-5	TECHNICAL FIELDS SEARCHED (IPC) F16H F16C
Y	JP 2003 056677 A (NSK LTD) 26 February 2003 (2003-02-26) * paragraphs [0014] - [0017] * * figures 1,2 *	1,3-5	
The present search report has been drawn up for all claims			
Place of search Munich		Date of completion of the search 2 July 2008	Examiner Werner, Michael
<p>CATEGORY OF CITED DOCUMENTS</p> <p>X : particularly relevant if taken alone                      Y : particularly relevant if combined with another document of the same category                      A : technological background                      O : non-written disclosure                      P : intermediate document</p> <p>T : theory or principle underlying the invention                      E : earlier patent document, but published on, or after the filing date                      D : document cited in the application                      L : document cited for other reasons                      &amp; : member of the same patent family, corresponding document</p>			

5  
EPO FORM 1503 03.82 (F04C01)

**ANNEX TO THE EUROPEAN SEARCH REPORT  
ON EUROPEAN PATENT APPLICATION NO.**

EP 08 00 4300

This annex lists the patent family members relating to the patent documents cited in the above-mentioned European search report. The members are as contained in the European Patent Office EDP file on  
The European Patent Office is in no way liable for these particulars which are merely given for the purpose of information.

02-07-2008

Patent document cited in search report	Publication date	Patent family member(s)	Publication date
JP 2005220957 A	18-08-2005	NONE	
JP 2004286179 A	14-10-2004	NONE	
US 3990136 A	09-11-1976	JP 994639 C JP 51082850 A JP 54027501 B	22-04-1980 20-07-1976 10-09-1979
JP 2004162858 A	10-06-2004	NONE	
US 2845696 A	05-08-1958	NONE	
JP 2003056677 A	26-02-2003	NONE	

EPO FORM P0459

For more details about this annex : see Official Journal of the European Patent Office, No. 12/82