

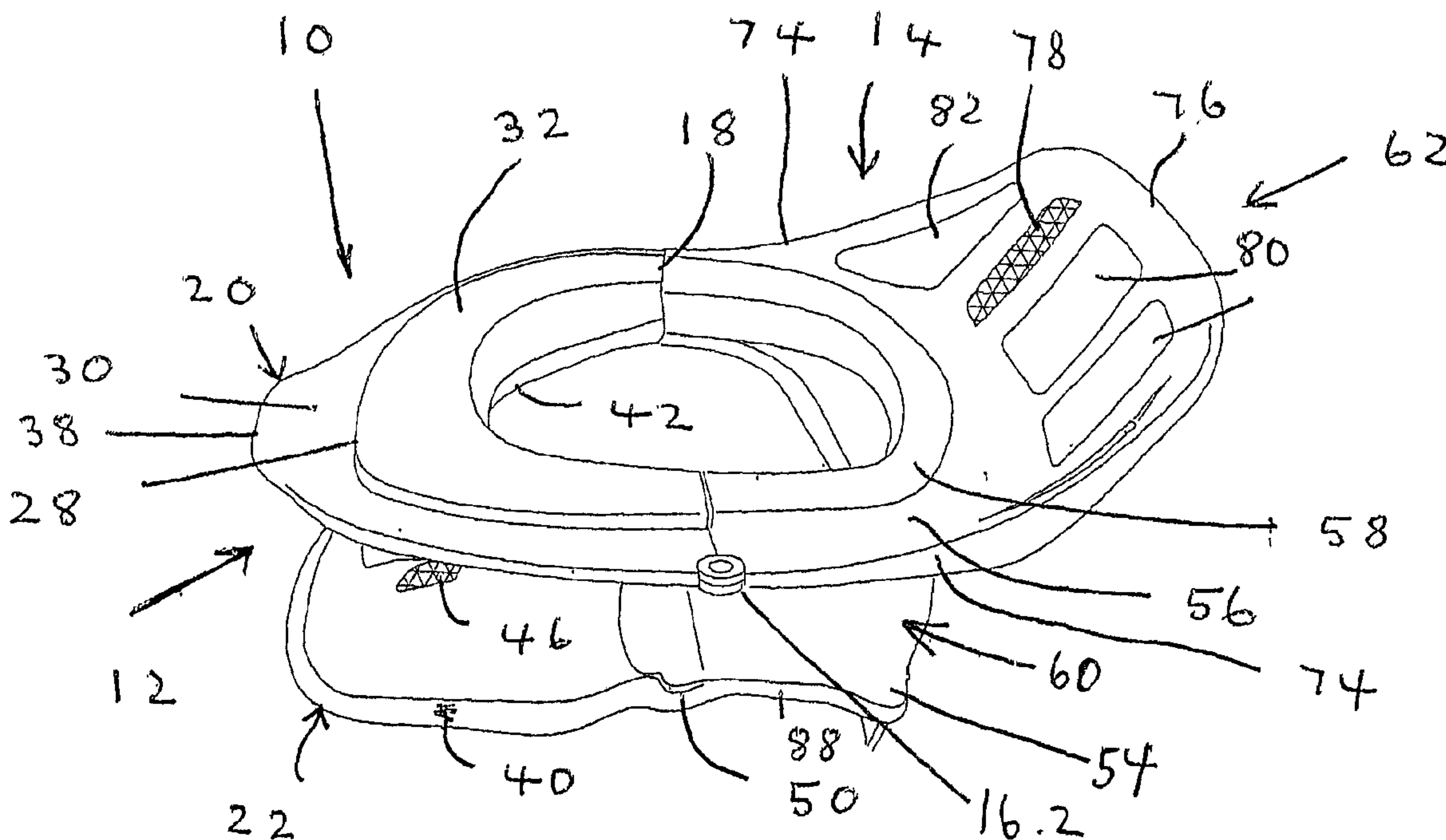

(86) Date de dépôt PCT/PCT Filing Date: 2004/11/26  
 (87) Date publication PCT/PCT Publication Date: 2005/06/09  
 (45) Date de délivrance/Issue Date: 2014/05/27  
 (85) Entrée phase nationale/National Entry: 2006/05/26  
 (86) N° demande PCT/PCT Application No.: ZA 2004/000148  
 (87) N° publication PCT/PCT Publication No.: 2005/051251  
 (30) Priorité/Priority: 2003/11/26 (ZA2003/9174)

(51) Cl.Int./Int.Cl. *A61F 5/055* (2006.01)  
 (72) Inventeur/Inventor:  
 LEATT, CHRISTOPHER JAMES, ZA  
 (73) Propriétaire/Owner:  
 XCEED HOLDINGS (PTY) LTD, ZA  
 (74) Agent: NORTON ROSE FULBRIGHT CANADA  
 LLP/S.E.N.C.R.L., S.R.L.

(54) Titre : MINERVE  
 (54) Title: NECK BRACE



(57) Abrégé/Abstract:

A neck brace (10) is disclosed which comprises two sections (12, 14) which are releasably connected to one another along a split line (18). The ring has upwardly facing surfaces (30, 76.1, 20.2) which limit tilting movement of a helmeted head in all directions. The brace further has a column (68, 70) which extends downwardly from the ring for transferring loads to the wearer's back on each side of the spine.



(12) INTERNATIONAL APPLICATION PUBLISHED UNDER THE PATENT COOPERATION TREATY (PCT)

(19) World Intellectual Property  
Organization  
International Bureau



(43) International Publication Date  
9 June 2005 (09.06.2005)

PCT

(10) International Publication Number  
**WO 2005/051251 A3**

(51) International Patent Classification<sup>7</sup>: **A61F 5/055**

GB, GD, GE, GH, GM, HR, HU, ID, IL, IN, IS, JP, KE, KG, KP, KR, KZ, LC, LK, LR, LS, LT, LU, LV, MA, MD, MG, MK, MN, MW, MX, MZ, NA, NI, NO, NZ, OM, PG, PH, PL, PT, RO, RU, SC, SD, SE, SG, SK, SL, SY, TJ, TM, TN, TR, TT, TZ, UA, UG, US, UZ, VC, VN, YU, ZA, ZM, ZW.

(21) International Application Number:  
PCT/ZA2004/000148

(22) International Filing Date:  
26 November 2004 (26.11.2004)

(25) Filing Language: English

(84) Designated States (unless otherwise indicated, for every kind of regional protection available): ARIPO (BW, GH, GM, KE, LS, MW, MZ, NA, SD, SL, SZ, TZ, UG, ZM, ZW), Eurasian (AM, AZ, BY, KG, KZ, MD, RU, TJ, TM), European (AT, BE, BG, CH, CY, CZ, DE, DK, EE, ES, FI, FR, GB, GR, HU, IE, IS, IT, LU, MC, NL, PL, PT, RO, SE, SI, SK, TR), OAPI (BF, BJ, CF, CG, CI, CM, GA, GN, GQ, GW, ML, MR, NE, SN, TD, TG).

(26) Publication Language: English

(30) Priority Data:  
2003/9174 26 November 2003 (26.11.2003) ZA

(71) Applicant and  
(72) Inventor: LEATT, Christopher, James [ZA/ZA]; 4 de Cock Avenue, 7800 Constantia (ZA).

(74) Agent: BACON, Brian; Brian Bacon & Associates Inc., 2nd floor, Mariendahl House, Newlands on Main, Main Road, 7700 Newlands (ZA).

**Published:**  
— with international search report  
— before the expiration of the time limit for amending the claims and to be republished in the event of receipt of amendments

(81) Designated States (unless otherwise indicated, for every kind of national protection available): AE, AG, AL, AM, AT, AU, AZ, BA, BB, BG, BR, BW, BY, BZ, CA, CH, CN, CO, CR, CU, CZ, DE, DK, DM, DZ, EC, EE, EG, ES, FI,

(88) Date of publication of the international search report:  
11 August 2005

[Continued on next page]

(54) Title: NECK BRACE

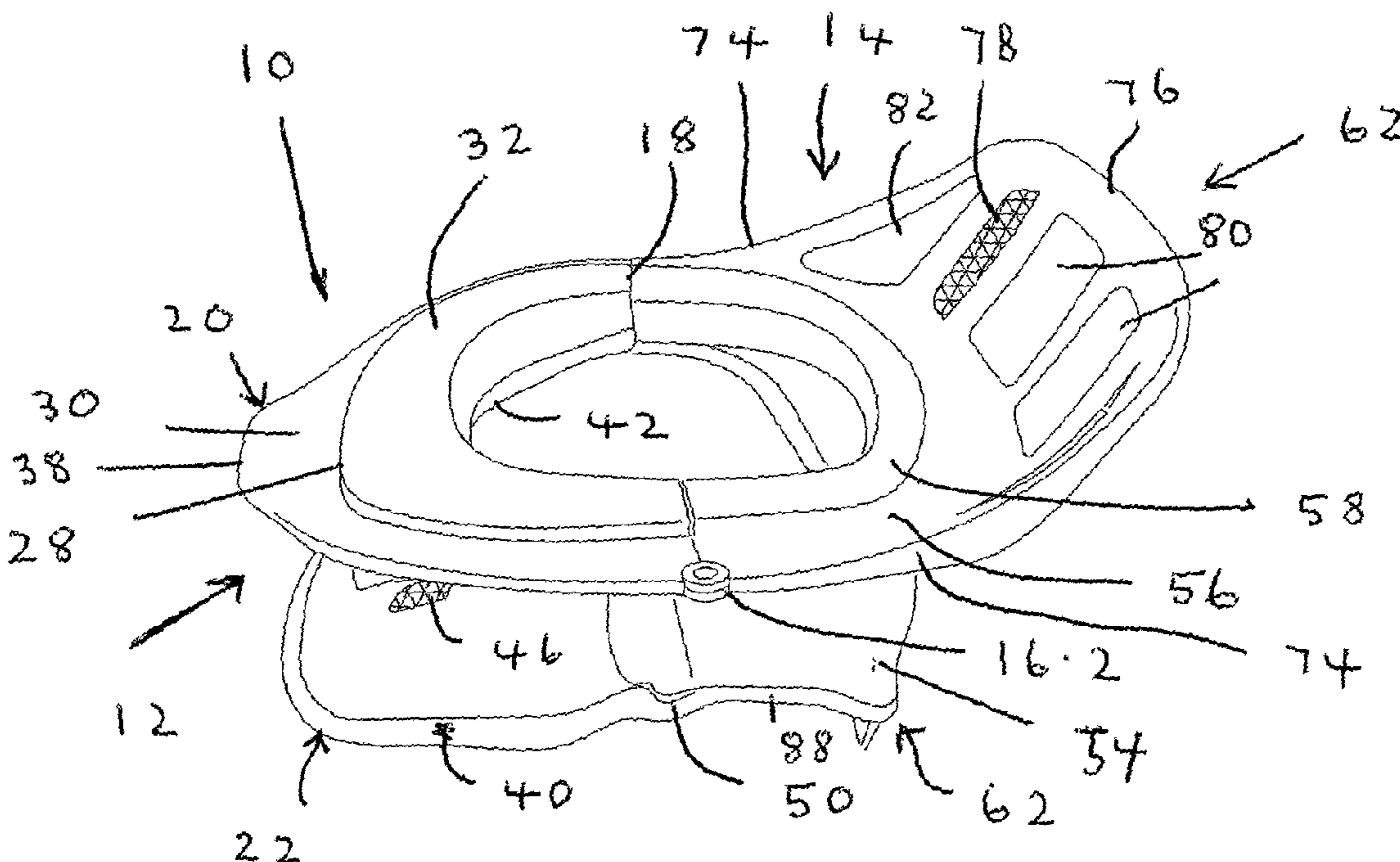

(57) Abstract: A neck brace (10) is disclosed which comprises two sections (12, 14) which are releasably connected to one another along a split line (18). The ring has upwardly facing surfaces (30, 76.1, 20.2) which limit tilting movement of a helmeted head in all directions. The brace further has a column (68, 70) which extends downwardly from the ring for transferring loads to the wearer's back on each side of the spine.

WO 2005/051251 A3

**WO 2005/051251 A3**



---

*For two-letter codes and other abbreviations, refer to the "Guidance Notes on Codes and Abbreviations" appearing at the beginning of each regular issue of the PCT Gazette.*

-1-

## NECK BRACE

### FIELD OF THE INVENTION

THIS INVENTION relates to neck braces.

### BACKGROUND TO THE INVENTION

A neck brace is generally used to support and immobilise the neck of the wearer after the wearer has sustained a neck injury.

The purpose of the neck brace of the present invention is to provide protection against most types of neck injuries such as fractures which may be sustained by a user, especially by a participant in a sport activity where there is a risk of serious neck injury such as high speed motor sports.

### BRIEF DESCRIPTION OF THE INVENTION

According to a first aspect of the present invention there is provided a neck brace comprising a ring which fits around the wearer's neck, a column which depends from the ring at a position at the rear of the ring so that it extends down the wearer's back, and cushioning along the vertical edges of the column for transmitting to the wearer's back, on each side of the spine, impact loads which are imposed on the brace.

According to a second aspect of the present invention there is provided

-2-

a neck brace which comprises a ring for fitting around the wearer's neck, an upper extension which protrudes from the ring in the rearward direction and a wall extending upwardly from said rearward extension for contacting the underside of the rear edge of a crash helmet and limiting tilting of the helmet in the rearward direction, a lower rearward extension, a column which depends from said lower rearward extension so that it extends down the wearer's back, and cushioning along the vertical edges of the column for transmitting to the wearer's back, on each side of the spine, impact loads which are imposed on the brace.

According to a third aspect of the present invention there is provided a neck brace comprising a ring which fits around the wearer's neck, the brace having an extension which protrudes from the ring in the rearward direction and a wall extending upwardly from said rearward extension for contacting the underside of the rear edge of a crash helmet and limiting tilting of the helmet in the rearward direction.

Said wall, in plan view, can be of curving configuration and extend across the rear of the brace and part of the way along each side of the brace, the part of the wall which extends across the rear of the brace being of substantially constant height and the parts of the wall at the sides of the brace decreasing in height with increasing distance from the part of the wall which extends across the brace.

Preferably said wall slopes in the rearward direction thereby to provide

-3-

an upwardly facing inclined surface which is positioned to intercept tilting movement and also projection of the rear part of the helmet.

According to a fourth aspect of the present invention there is provided a neck brace comprising a ring which fits around the wearer's neck, a forward and downward extension from said ring, and cushioning on the underside of the extension for bearing on the wearer's chest and transmitting to the chest impact loads that are imposed on the brace.

According to a fifth aspect of the present invention there is provided a neck brace comprising a ring which fits around the wearer's neck, a forward extension of the ring providing an upwardly facing impact surface which, when the brace is used with a full face crash helmet, limits downward tilting of the helmet by contacting the underside of the face guard of the helmet.

According to a sixth aspect of the present invention there is provided a neck brace comprising a ring which fits around the wearer's neck, an upper forward extension of the ring providing an upwardly facing impact surface which, when the brace is used with a full face crash helmet, limits downward tilting of the helmet by contacting the underside of the face guard of the helmet, a lower forward extension of the ring, cushioning on the underside of the lower extension for bearing on the wearer's chest and transmitting to the chest impact loads that are imposed on the brace, and a wall joining the upper and lower forward extensions, the wall being hollow and bounded by a radially outer skin and a radially inner skin.

In the preferred form said upper extension is hollow and bounded by an upper skin and a lower skin, the hollow interior of the upper extension communicating with the space between said inner and outer skins of the joining wall.

Said ring can comprise a U-shaped front section and a U-shaped rear section, there being releasable latching means for fastening said sections to one another.

In one constructional form said column comprises a vertically extending bar depending from the ring, a plate wider than the bar secured to the bar and protruding laterally therefrom on each side thereof, said cushioning being carried by said plate.

The wall joining the upper and lower forward extensions can be fabricated so that it constitutes a fracture zone.

In accordance with a further aspect, there is provided a neck brace, comprising:

a ring adapted to encircle a wearer's neck and provide a clearance between the ring and a front lower rim of a full face helmet when the helmet is worn by the wearer, the clearance allowing a range of freedom of movement of the helmet above the ring, the ring comprising:

a front section constructed and arranged to limit forward tilt of the helmet through contact of the front lower rim of the helmet with the front section of the ring, and

a rear section constructed and arranged to limit rearward tilt of the helmet through contact of a rear lower rim of the helmet with the rear section of the ring;

a lower forward extension coupled to the ring and having sufficient rigidity to transfer to the wearer's chest at least some of a force applied to the front section of the ring by the front lower rim of the helmet; and

a lower rearward extension coupled to the ring and having sufficient rigidity to transfer to the wearer's back at least some of a force applied to the rear section of the ring by the rear lower rim of the helmet.

In accordance with a further aspect, there is provided a neck brace, comprising:

a front section having a first upwardly facing surface;

a rear section having a second upwardly facing surface and constructed and arranged to releasably couple to the front section, such that the neck of a wearer is encircled

-4a-

and such that a helmet having a full face and worn by the user has lateral rotation above the front and rear sections;

a front downward extension coupled to the front section and having sufficient rigidity to transfer to the wearer's front at least some of a force applied to the first upwardly facing surface by the front lower rim of the helmet; and

a rear downward extension coupled to the rear section and having sufficient rigidity to transfer to the wearer's back at least some of a force applied to the second upwardly facing surface by a rear lower rim of the helmet.

In accordance with a further aspect, there is provided a neck brace comprising:

a ring constructed and arranged to encircle a wearer's neck and provide a clearance between the ring and a front lower rim of a helmet having a full face when the helmet is worn by the wearer, the clearance allowing a range of freedom of movement of the helmet above the ring, the ring including,

a front generally upwardly facing impact surface constructed and arranged to limit forward tilt of a helmet through contact of the front lower rim of the full face of the helmet with the front generally upwardly facing impact surface of the ring; and

a rear generally upwardly facing impact surface constructed and arranged to limit rearward tilt of the helmet through contact of the rear lower rim of the helmet with the rear generally upwardly facing impact surface of the ring;

a lower forward extension coupled to the ring and having sufficient rigidity to transfer to the wearer's front at least some of a force applied to the front generally upwardly facing impact surface by the front lower rim of the full face of the helmet;

a lower rearward extension coupled to the ring and having sufficient rigidity to transfer to the wearer's back at least some of a force applied to the rear generally upwardly facing impact surface by the rear lower rim of the helmet; and

a rigid wall that extends between the ring and the lower forward extension.

In accordance with a further aspect, there is provided a neck brace, comprising:

a ring adapted to substantially encircle a wearer's neck and to provide a clearance between the ring and a front lower rim of a full face helmet when the helmet is

-4b-

worn by the wearer, the clearance allowing a range of freedom of movement of the helmet above the ring, the ring having a front section constructed and arranged to limit forward tilt of the helmet through contact of the front lower rim of the helmet with the front section of the ring; and

a lower forward member extending from the ring and having sufficient rigidity to transfer to the wearer's chest at least some of a force applied to the front section of the ring by the front lower rim of the helmet.

In accordance with a further aspect, there is provided a neck brace, comprising:

a ring adapted to substantially encircle a wearer's neck and to provide a clearance between the ring and a front lower rim of a full face helmet when the helmet is worn by the wearer, the clearance allowing a range of freedom of movement of the helmet above the ring, the ring having an upwardly extending rear surface configured to limit rearward tilt of the helmet through contact of a rear lower rim of the helmet with the upwardly extending rear surface; and

a lower rear member extending from the ring and having sufficient rigidity to transfer to the wearer's back at least some of a force applied to the upwardly extending rear surface by the rear lower rim of the helmet.

In accordance with a further aspect, there is provided a neck brace, comprising:

a first U-shaped section adapted to be operatively positioned around the neck of a wearer and configured to allow clearance between a lower rim of a full face helmet when worn on the wearer's head and the first U-shaped section, the clearance allowing freedom of movement of the helmet above the first U-shaped section, the first U-shaped section including a rear section configured to limit tilt of the helmet through contact of a rear lower rim of the helmet with the rear section of the first U-shaped section; and

a lower section, extending from the first U-shaped section, and having sufficient rigidity to transfer to the wearer's back at least some of a force applied to the rear section of the first U-shaped section by the rear lower rim of the helmet.

4c

**BRIEF DESCRIPTION OF THE DRAWINGS**

For a better understanding of the present invention, and to show how the same may be carried into effect, reference will now be made, by way of example, to the accompanying drawings in which:-

Figure 1 is a front elevation of a neck brace according to the present invention;

Figure 2 is a pictorial view of the neck brace;

-5-

Figure 3 is a top plan view of the neck brace;

Figure 4 is an underneath plan view of the neck brace;

Figure 5 is a rear elevation of the neck brace;

Figure 6 is a side elevation of the neck brace;

Figure 7 is a front elevation of a further neck brace according to the present invention;

Figure 8 is a pictorial view from one side and above of the brace of Figure 7;

Figure 9 is a top plan view of the neck brace of Figure 7;

Figure 10 is an underneath plan view of the neck brace of Figure 7;

Figure 11 is a rear elevation of the brace of Figure 7; and

Figure 12 is a side elevation of the brace of Figure 7.

#### DETAILED DESCRIPTION OF THE DRAWINGS

The neck brace illustrated in Figures 1 to 6 is generally designated 10 and comprises a front section 12 and a rear section 14 which are secured together to form a ring which goes around the wearer's neck. The connection can comprise two spring loaded latches or, preferably, one spring loaded latch 16.1 and a hinge 16.2. The split line between the front and rear sections is designed 18.

The front section 12 is U-shaped in plan and includes a hollow top flange 20 and a lower forward extension in the form of a solid bottom flange 22 which are joined by a composite wall 24.

The top flange has an upper face which is stepped along the curving line 28 to provide an upwardly facing outer surface 30 and an upwardly facing inner

-6-

surface. The outer surface 30 is above the inner surface. The inner surface is not visible in the drawings as it is concealed by a piece of horse-shoe shaped cushioning 32. The cushioning 32 is releasably secured to said inner surface by, for example, a strip of the "hook and loop" fastener (not shown), which is generally sold under the trade mark "Velcro", fixed to the transverse portion of the inner, lower surface. The cushioning 32 protrudes above the surface 30.

The top flange 20, when its rear end is viewed along the split line 18, slopes in such a manner that the inner edge of the inner, lower surface is below its outer edge, and the inner edge of the surface 30 is below its outer edge. The front, transversely extending portion of the surface 30 is wider in the radial direction than the side portions of this surface and curves upwardly (see particularly Figure 6) to form a forwardly facing lip designated 38.

The bottom flange 22 is wider than the top flange 20 and protrudes beyond the top flange both laterally and in the forward direction. The underside of the flange 22 has a layer of cushioning material 40 secured thereto. The layer 40, when the brace 10 is being worn, is in contact with the part of the wearer's chest which is immediately below the neck.

The wall 24 which joins the flanges 20, 22 is of double skin hollow construction at the forward end of the section 12 and of single skin construction towards the free ends of the limbs of the U-shaped section 12.

-7-

The inner edges of the flanges 20, 22 of the section 12 are joined by a curving inner skin 42 of the wall 24. The outer skin of the wall is designated 44 and extends from the underside of the top flange 20 to the top surface of the bottom flange 22.

The bottom flange 22 is constituted by a single skin whereas the top flange 20, as mentioned above, is of hollow construction. The upper skin of the top flange 20 provides the surface 30, the surface to which the cushioning 32 is fixed and the top surface of the lip 38. The lower skin forms the underside of the lip 38 and merges with the outer skin 44 of the wall 24.

Thus the forward part of the neck brace is hollow, the internal space being bounded by the top and bottom flanges 20, 22 and by the skins of the wall 24. The hollow lip 38 forms a forward extension of the space between the skins 42, 44 and the flanges 20, 22.

Air vents (not shown) are provided in the skin 44 and further air vents 46 are provided in the flange 22. These vents all communicate with said internal space and allow air to flow through the hollow front section of the brace.

The free edges of the lower flanges are stepped down at 50 (see Figure 2) to allow the two sections 12, 14 to be overlapped as will be described in more detail later.

-8-

The rear section 14 includes top and bottom flanges 52, 54 which form continuations of the top and bottom flanges 20, 22 of the front section 12 when the sections are joined.

The top flange 52 is configured with a step in it so that its upper surface has a radially inner part which is lower than the radially outer part. The radially outer part is designated 56 and the radially inner part has cushioning 58 secured to it by one or more strips of "Velcro". The flange 52 is hollow and bounded by an upper skin constituting the stepped top surface of the flange and by a lower skin.

The rear of the brace is constituted by a first wall designated 60 and a second wall designated 62.

The bottom flanges 54 curve downwardly at their rear ends to merge with the wall 60, and the bottom flanges 54 and wall 60, together, form a lower rearward extension. Air vents 64 are provided in the wall 60 and there is a vertically extending recess 66 in the centre of the rearwardly facing surface of the wall 60.

A bar 68 has its upper end in the recess 66 and is screwed to the wall 60. A plate 70 which is wider than the bar 68 is secured to the bar 68 by screws or other suitable means and protrudes in both horizontal directions beyond the bar 68. A U-shaped pad 72 of cushioning material is secured to the forwardly facing surface of the plate 70. The bar 68 and plate 70 constitute a column.

-9-

A wedge shaped shim (not shown) can be fitted between the bar 68 and the wall 60 so as to cause the bar to adopt a non-vertical orientation.

Alternatively, two wedge shape shims in face-to-face contact can be used to displace the bar 68 rearwardly with respect to the wall 60 whilst leaving it vertical.

Shims can also be used between the bar 68 and plate 70 so as to angle the plate 70 with respect to the bar, or displace it rearwardly with respect to the bar.

The wall 62 constitutes an upward extension of the part 56 of the flange 52. The wall 62, in plan, has side sections 74 of generally triangular shape which increase in height towards the zones where they merge with a transverse section 76 of the wall 62. The section 76 slopes in the rearward direction to provide a surface 76.1 (see Figure 1) and has two mesh covered air vents 78 in it. On its forwardly facing surface the section 76 has two cushioning pads 80 and there are further cushioning pads 82 on the inner faces of the sections 74.

Pads 88 of cushioning material are provided on the underside of the flanges 54.

The forward edges of the flanges 54 are configured so that they overlap with the rear edges of the flanges 22 (see Figure 2).

The latch 16.1 is mounted on the section 14 and comprises a spring

-10-

loaded locking bar which is in a socket of the flange 54 and can be manually displaced by an actuating element external of the flange. A tang (not shown) is secured to the section 12 and enters the socket containing the locking bar when the sections 12 and 14 are being joined. The tang has an angled slot in its side edge. The tang cams the locking bar to one side against spring action until the bar enters the angled slot. Only by manually displacing the locking bar out of the slot can the sections 12, 14 be separated.

The top edge and the inclined forward face 76.1 of the wall section 76 lie close to the wearer's crash helmet and limit both projection and rearward tilting movement of the head. The column constituted by the bar 68 and plate 70 transmits, via the pad 72, impact loads to the wearer's back. These loads are imposed not on the spine but on two zones lying one on each side of the spine.

The top flange 20 of the front section lies below the lower rim of a helmet of the full face type and thus limits forward tilting motion of a helmeted head. The front part of the flange 22 lies on the wearer's chest and transmits loads to it through the cushioning 40 on the underside of the flange 22.

Most of the features of the brace of Figures 7 to 12 are common to it and to the brace of Figures 1 to 6. Like parts have been designated with like references to which the suffix ".1" has been added.

The most significant difference between the two braces is that the wall

-11-

section 76 of Figures 1 to 6 is of far smaller height as can best be seen in Figure 12. The wall section 76 limits movement of the helmet and head in the direction of the arrow A. Such movement is referred to, in medical terms, as "projection". The upper surface of the brace limits tilting of the head and helmet in the direction indicated by the arrow B.

Both braces illustrated are fabricated using resin and glass fibre or carbon fibre and a fabric such as "Kevlar" which are embedded in the resin. "Kevlar" is the strongest of these materials and is used on the inside of the brace. Thus if the brace does fracture, it fractures preferentially on the outside. Any fragments that break off are thus outside the brace and not adjacent the wearer's neck.

The braces are fabricated in such manner that certain zones are weaker than the remainder of the structure of the brace. In the event of an impact, these zones collapse before any other parts of the brace and absorb the forces exerted as a result of the impact. The fracture zones are marked FZ in Figures 5 and 6. The same zones exist in the brace shown in Figures 7 to 12, but the fracture zones are not marked in Figures 7 to 12.

These zones are created by, for example, using fabric of lesser strength, by making the zones thinner than the surrounding parts of the brace, or by configuring the brace such that fracturing naturally occurs at the desired zones.

The braces described are intended to be worn not by a person who has suffered a neck injury but by a person whose activities increase the chances

-12-

that a neck injury will be suffered.

By providing a rigid sub-structure of resin covered with cushioning material, and building fracture zones into the rigid sub-structure, it is possible to minimise the transmission of impact shocks to the wearer's neck region by absorbing the shocks. The lip 38, which forms a forward extension of the ring, controls forward tilting movement of the helmeted head. The lower edge of the rear part of the helmet is adjacent the sloping face 76.1 of the wall section 76 and limits both projection and tilting of the helmeted head. Finally the surfaces 20.2 of the top flanges which lie on opposite sides of the neck (see particularly Figures 1 and 11) inhibit sideways movement of the head by contact between themselves and the helmet.

## CLAIMS

## 1. A neck brace, comprising:

a ring adapted to encircle a wearer's neck and provide a clearance between the ring and a front lower rim of a full face helmet when the helmet is worn by the wearer, the clearance allowing a range of freedom of movement of the helmet above the ring, the ring comprising:

a front section constructed and arranged to limit forward tilt of the helmet through contact of the front lower rim of the helmet with the front section of the ring, and

a rear section constructed and arranged to limit rearward tilt of the helmet through contact of a rear lower rim of the helmet with the rear section of the ring;

a lower forward extension coupled to the ring and having sufficient rigidity to transfer to the wearer's chest at least some of a force applied to the front section of the ring by the front lower rim of the helmet; and

a lower rearward extension coupled to the ring and having sufficient rigidity to transfer to the wearer's back at least some of a force applied to the rear section of the ring by the rear lower rim of the helmet.

## 2. The neck brace of claim 1, wherein the ring comprises two U-shaped sections.

## 3. The neck brace of claim 2, wherein the U-shaped sections are configured to releasably latch together.

## 4. The neck brace of claim 1, further comprising:

a rigid wall that couples the ring and the lower forward extension.

## 5. The neck brace of claim 4, wherein the ring extends outwardly beyond the rigid wall.

## 6. The neck brace of claim 1, wherein the ring further has a side surface constructed and arranged to limit sideward tilt of the helmet through contact of a side lower rim of the helmet and the side surface of the ring.

7. The neck brace of claim 1, further comprising:

a first fracture zone adjacent the front section, configured to collapse prior to the remainder of the brace collapsing in response to a force applied to the front section of the ring by the lower rim of the helmet, thereby absorbing at least some of the force.

8. The neck brace of claim 7, wherein the rear section includes an upwardly extending rear surface constructed and arranged to limit rearward tilt of the helmet through contact of the rear lower rim of the helmet and the upwardly extending rear surface.

9. The neck brace of claim 8, further comprising:

a second fracture zone adjacent the upwardly extending rear surface, the second fracture zone configured to collapse prior to the remainder of the brace collapsing in response to a second force applied to the upwardly facing rear surface of the ring by the rear lower rim of the helmet, thereby absorbing at least some of the second force.

10. The neck brace of claim 9, wherein at least one of the first and second fracture zones is formed by using one or more materials collectively having a strength that is less than the strength of the materials forming the remainder of the brace.

11. The neck brace of claim 9, wherein at least one of the first and second fracture zones has walls that are thinner than the walls forming the remainder of the brace.

12. The neck brace of claim 1, wherein the lower rearward extension includes a column extending from the ring down the wearer's back.

13. The neck brace of claim 12, wherein the column is configured for transferring the forces to the wearer's back adjacent the spine.

14. A neck brace, comprising:

a front section having a first upwardly facing surface;

a rear section having a second upwardly facing surface and constructed and arranged to releasably couple to the front section, such that the neck of a wearer is encircled and such

that a helmet having a full face and worn by the user has lateral rotation above the front and rear sections;

a lower forward extension coupled to the front section and having sufficient rigidity to transfer to the wearer's front at least some of a force applied to the first upwardly facing surface by the front lower rim of the helmet; and

a lower rearward extension coupled to the rear section and having sufficient rigidity to transfer to the wearer's back at least some of a force applied to the second upwardly facing surface by a rear lower rim of the helmet.

15. The neck brace of claim 14, further comprising:

a rigid wall that extends between the ring and the lower forward extension.

16. The neck brace of claim 15, wherein the first upwardly facing surface extends outwardly beyond the rigid wall.

17. The neck brace of claim 14, further comprising:

a first fracture zone adjacent the first upwardly facing surface, configured to collapse prior to the remainder of the brace collapsing in response to a force applied to the first upwardly facing surface by the front lower rim of the helmet, thereby absorbing at least some of the force.

18. The neck brace of claim 17, further comprising:

a second fracture zone adjacent the second upwardly facing surface, the second fracture zone configured to collapse prior to the remainder of the brace collapsing in response to a second force applied to the second upwardly facing surface by the rear lower rim of the helmet, thereby absorbing at least some of the second force.

19. The neck brace of claim 18, wherein at least one of the first and second fracture zones is formed by using one or more materials collectively having a strength that is less than the strength of the materials forming the remainder of the brace.

20. The neck brace of claim 18, wherein at least one of the first and second fracture zones has walls that are thinner than the walls forming the remainder of the brace.
21. The neck brace of claim 14, wherein the lower rearward extension includes a column extending from the ring down the wearer's back.
22. The neck brace of claim 21, wherein the column is configured for transferring the forces to the wearer's back adjacent the spine.
23. A neck brace comprising:  
a ring constructed and arranged to encircle a wearer's neck and provide a clearance between the ring and a front lower rim of a helmet having a full face when the helmet is worn by the wearer, the clearance allowing a range of freedom of movement of the helmet above the ring, the ring including,  
a front generally upwardly facing impact surface constructed and arranged to limit forward tilt of a helmet through contact of the front lower rim of the full face of the helmet with the front generally upwardly facing impact surface of the ring; and  
a rear generally upwardly facing impact surface constructed and arranged to limit rearward tilt of the helmet through contact of the rear lower rim of the helmet with the rear generally upwardly facing impact surface of the ring;  
a lower forward extension coupled to the ring and having sufficient rigidity to transfer to the wearer's front at least some of a force applied to the front generally upwardly facing impact surface by the front lower rim of the full face of the helmet;  
a lower rearward extension coupled to the ring and having sufficient rigidity to transfer to the wearer's back at least some of a force applied to the rear generally upwardly facing impact surface by the rear lower rim of the helmet; and  
a rigid wall that extends between the ring and the lower forward extension.
24. The neck brace of claim 23, wherein the front generally upwardly facing impact surface extends outwardly beyond the rigid wall.
25. The neck brace of claim 23, wherein the ring comprises two U-shaped sections.

26. The neck brace of claim 25, wherein the U-shaped sections are configured to releasably latch together.
27. The neck brace of claim 23, further comprising:  
a fracture zone adjacent the front upwardly facing surface, configured to collapse prior to the remainder of the brace collapsing in response to a force applied to the first upwardly facing surface by the front lower rim of the helmet, thereby absorbing at least some of the force.
28. The neck brace of claim 27, further comprising:  
a fracture zone adjacent the rear upwardly facing surface, the fracture zone configured to collapse prior to the remainder of the brace collapsing in response to a force applied to the rear upwardly facing surface by the rear lower rim of the helmet, thereby absorbing at least some of the second force.
29. A neck brace, comprising:  
a ring adapted to encircle a wearer's neck and to provide a clearance between the ring and a front lower rim of a full face helmet when the helmet is worn by the wearer, the clearance allowing a range of freedom of movement of the helmet above the ring, the ring having an upwardly facing rear surface configured to limit rearward tilt of the helmet through contact of a rear lower rim of the helmet with the upwardly facing rear surface; and  
a lower rearward extension extending from the ring and having sufficient rigidity to transfer to the wearer's back at least some of a first force applied to the upwardly facing rear surface by the rear lower rim of the helmet.
30. The neck brace of claim 29, wherein the ring has a front section constructed and arranged to limit forward tilt of the helmet through contact of the front lower rim of the helmet with the front section of the ring.
31. The neck brace of claim 29, further comprising:

a lower forward extension extending from the ring and constructed and arranged to transfer to the wearer's chest at least some of a force applied to the front section of the ring by the front lower rim of the helmet.

32. The neck brace of claim 31, further comprising:

a rigid structure connected to and extending between the ring and the lower forward extension.

33. The neck brace of claim 32, wherein the ring extends outwardly beyond the rigid structure.

34. The neck brace of claim 29, wherein the ring further has a side surface constructed and arranged to limit sideward tilt of the helmet through contact of a side lower rim of the helmet and the side surface of the ring.

35. The neck brace of claim 29, further comprising:

a first fracture zone, adjacent the upwardly facing rear surface, configured to collapse prior to the remainder of the brace collapsing in response to a first force applied to the upwardly facing rear surface by the rear lower rim of the helmet thereby absorbing at least some of the first force.

36. The neck brace of claim 30, further comprising:

a fracture zone, adjacent the front section, configured to collapse prior to the remainder of the brace collapsing in response to a second force applied to the front section of the ring by the lower rim of the helmet thereby absorbing at least some of the second force.

37. The neck brace of claim 36, wherein the fracture zone is formed by using one or more materials collectively having a strength that is less than the strength of the remainder of the brace.

38. The neck brace of claim 35, wherein the first fracture zone has walls that are thinner than the walls forming the remainder of the brace.
39. The neck brace of claim 29, further comprising:  
flanges configured to prevent substantial rotation of the neck brace on the wearer.
40. The neck brace of claim 29, wherein the ring comprises:  
two U-shaped sections.
41. The neck brace of claim 40, wherein the U-shaped sections are configured to releasably latch together.
42. A neck brace, comprising:  
a first U-shaped section adapted to be operatively positioned around the neck of a wearer and configured to allow clearance between a lower rim of a full face helmet when worn on the wearer's head and the first U-shaped section, the clearance allowing freedom of movement of the helmet above the first U-shaped section, the first U-shaped section including a rear section configured to limit tilt of the helmet through contact of a rear lower rim of the helmet with the rear section of the first U-shaped section;  
a lower rearward extension, extending from the first U-shaped section, and having sufficient rigidity to transfer to the wearer's back at least some of a force applied to the rear section of the first U-shaped section by the rear lower rim of the helmet; and  
a second U-shaped section configured to releasably latch to the first U-shaped section so that the first and second U-shaped sections encircle the wearer's neck, the second U-shaped section including a front section.
43. The neck brace of claim 42, further comprising:  
a first fracture zone, adjacent the rear section, configured to collapse prior to the remainder of the brace collapsing in response to a force applied to the rear section of the U-shaped section by the rear lower rim of the helmet.

44. The neck brace of claim 43, further comprising:  
a second fracture zone, adjacent the front section, configured to collapse prior to the remainder of the brace collapsing in response to a second force applied to the front section of the U-shaped section by a front lower rim of the helmet.
45. The neck brace of claim 44, wherein at least one of the first and second fracture zones is formed by using one or more materials collectively having a strength that is less than the strength of the remainder of the brace.
46. The neck brace of claim 44, wherein at least one of the first and second fracture zones has walls that are thinner than the walls forming the remainder of the brace.
47. The neck brace of claim 42, wherein the first and second U-shaped sections further have a side surface constructed and arranged to limit sideward tilt of the helmet through contact of a side lower rim of the helmet and the side surface of the first and second U-shaped sections.
48. The neck brace of claim 42, further comprising:  
a rigid structure connected to and extending between the first and second U-shaped sections and a lower forward extension.
49. The neck brace of claim 48, wherein the first and second U-shaped sections extend outwardly beyond the rigid structure.
50. The neck brace of claim 42, further comprising:  
flanges configured to prevent substantial rotation of the neck brace on the wearer.

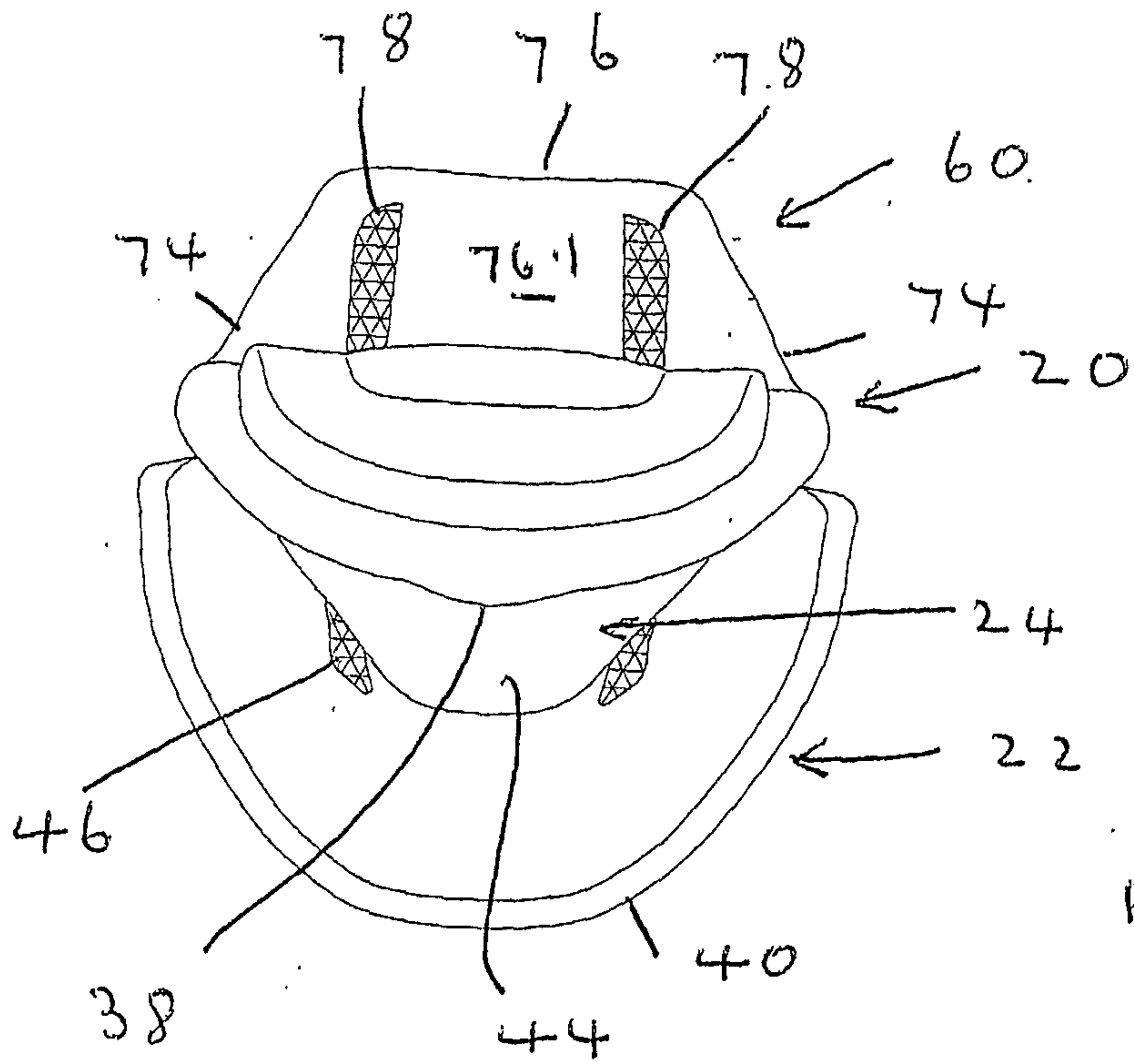

Fig. 1

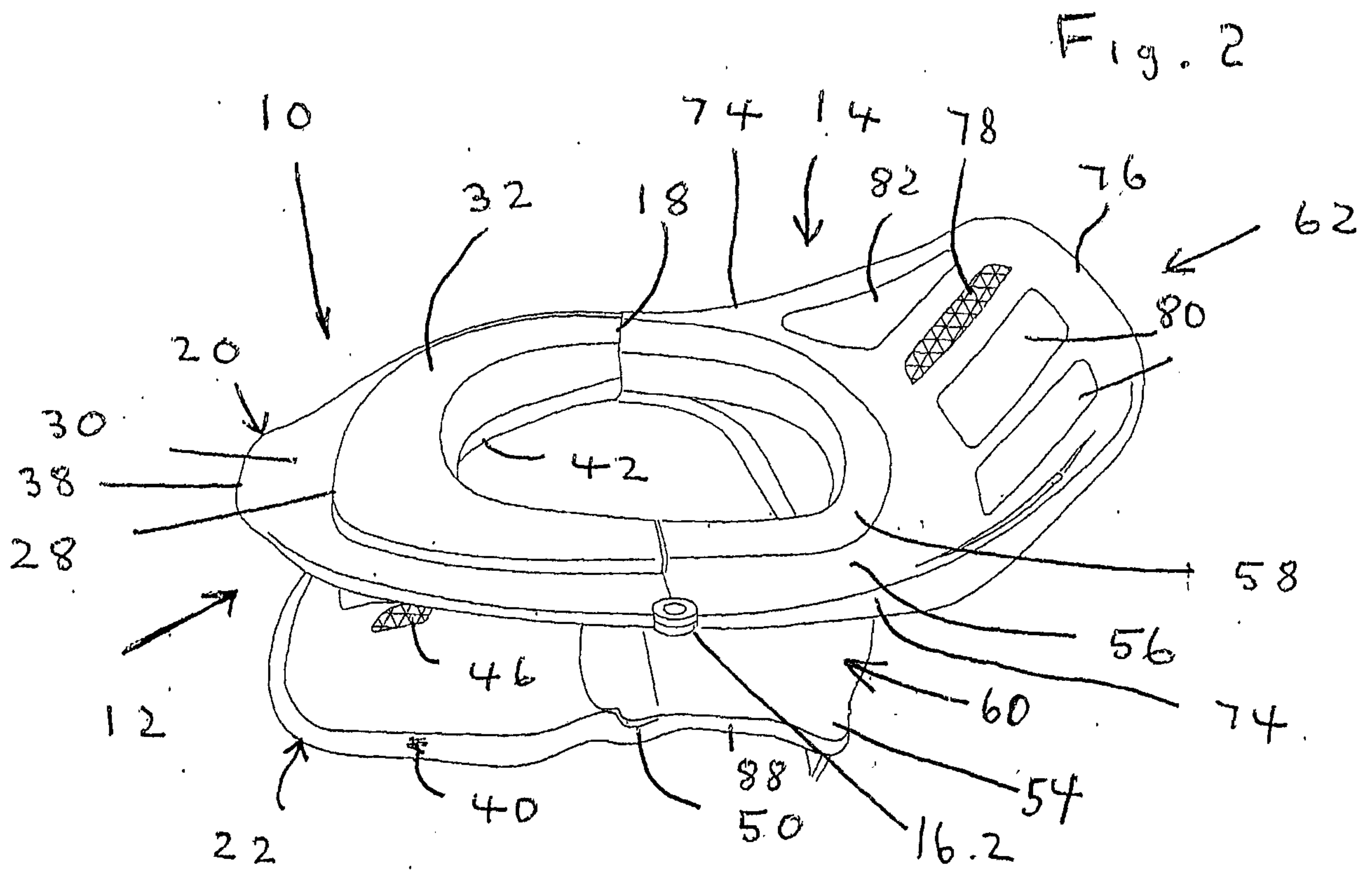

Fig. 2

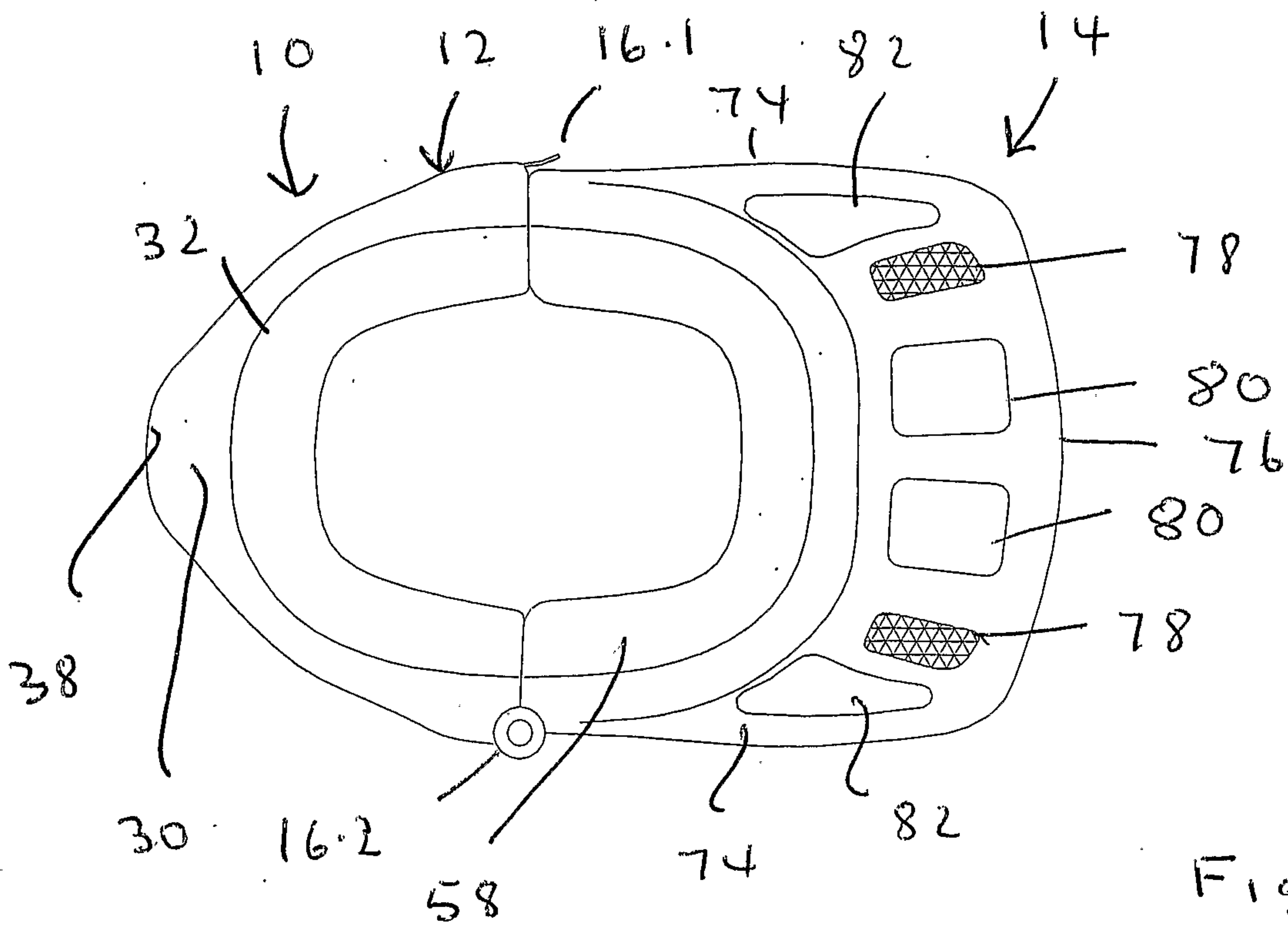

Fig. 3

2/6

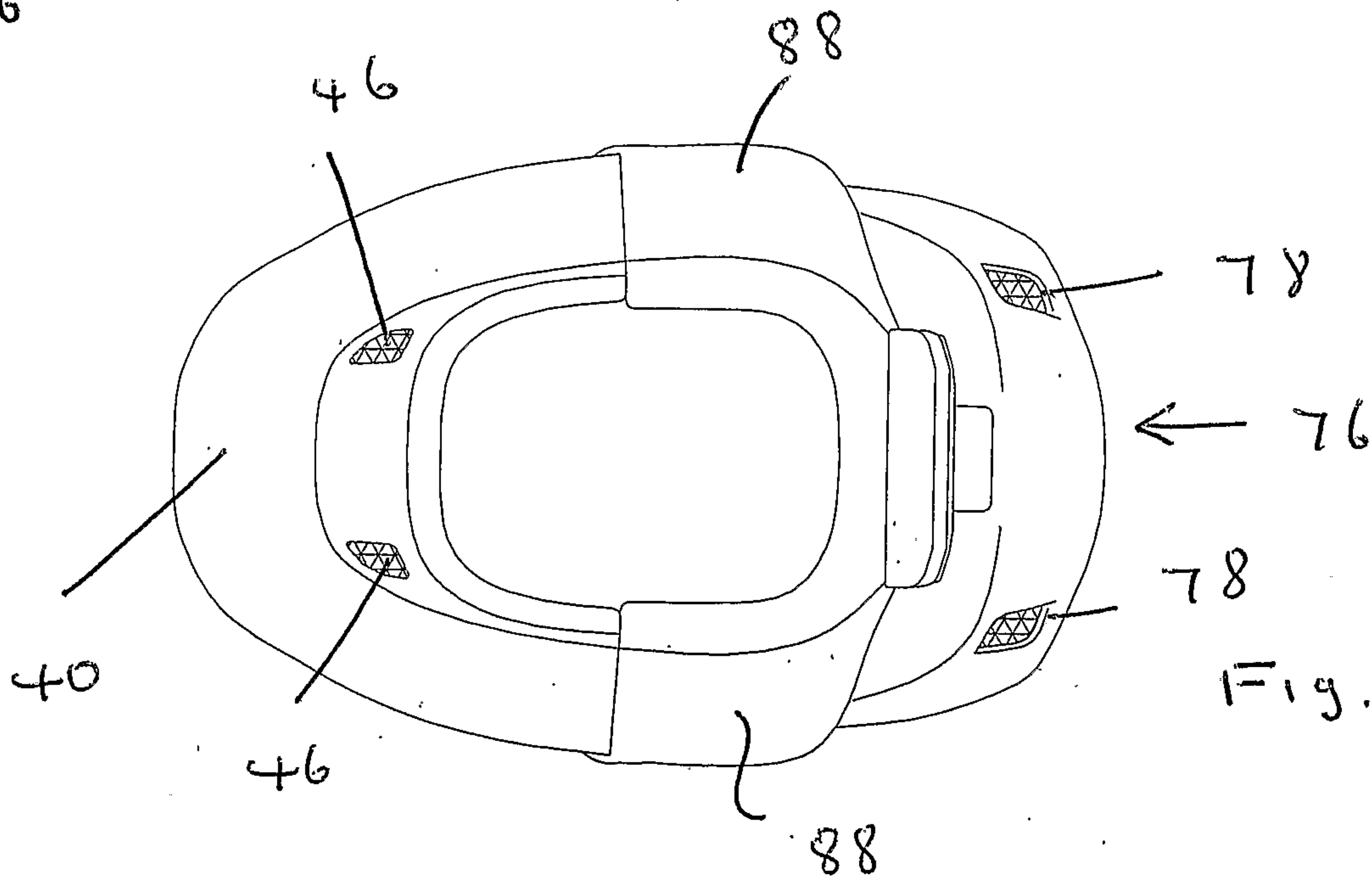

Fig. 4

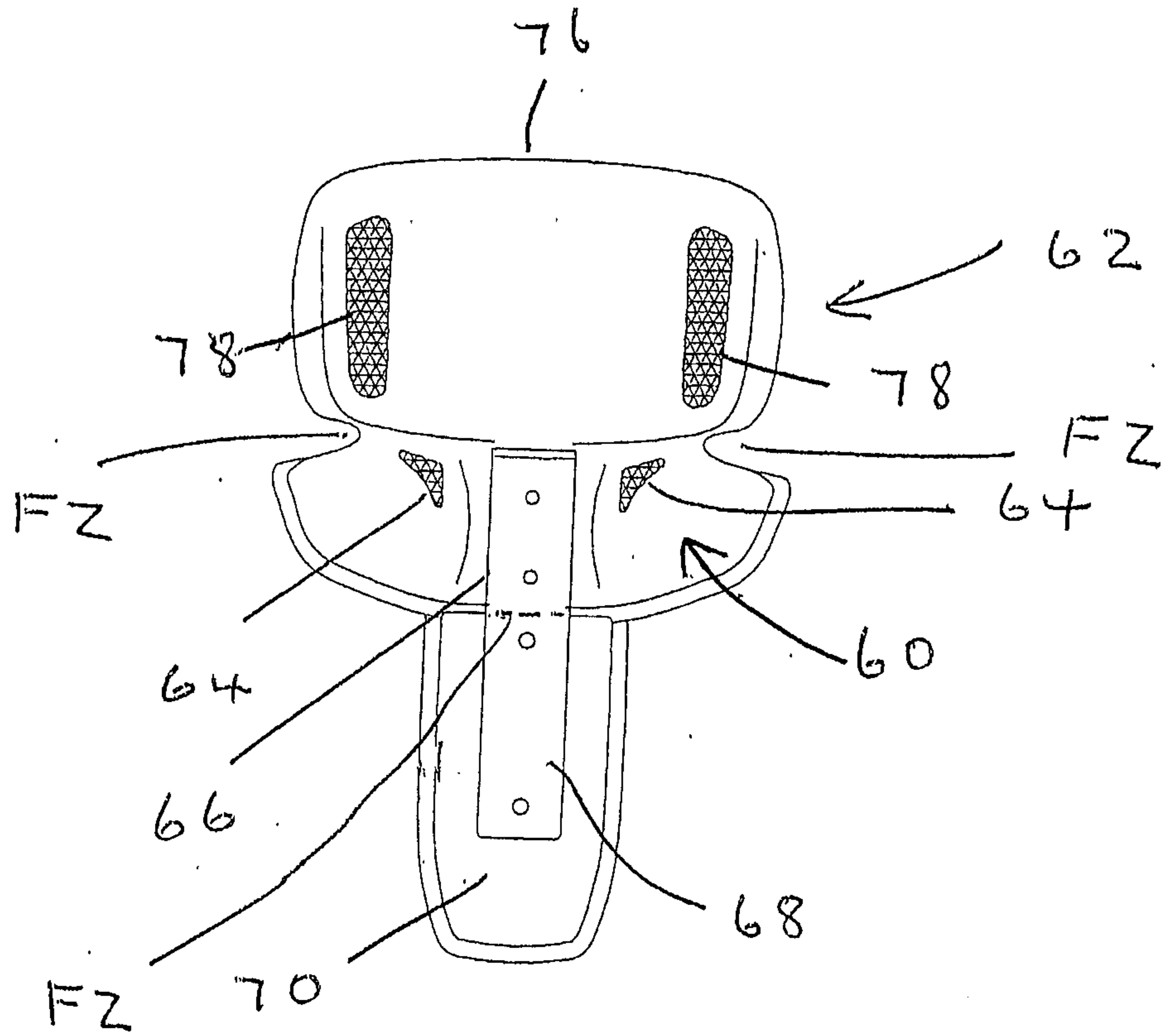

Fig. 5

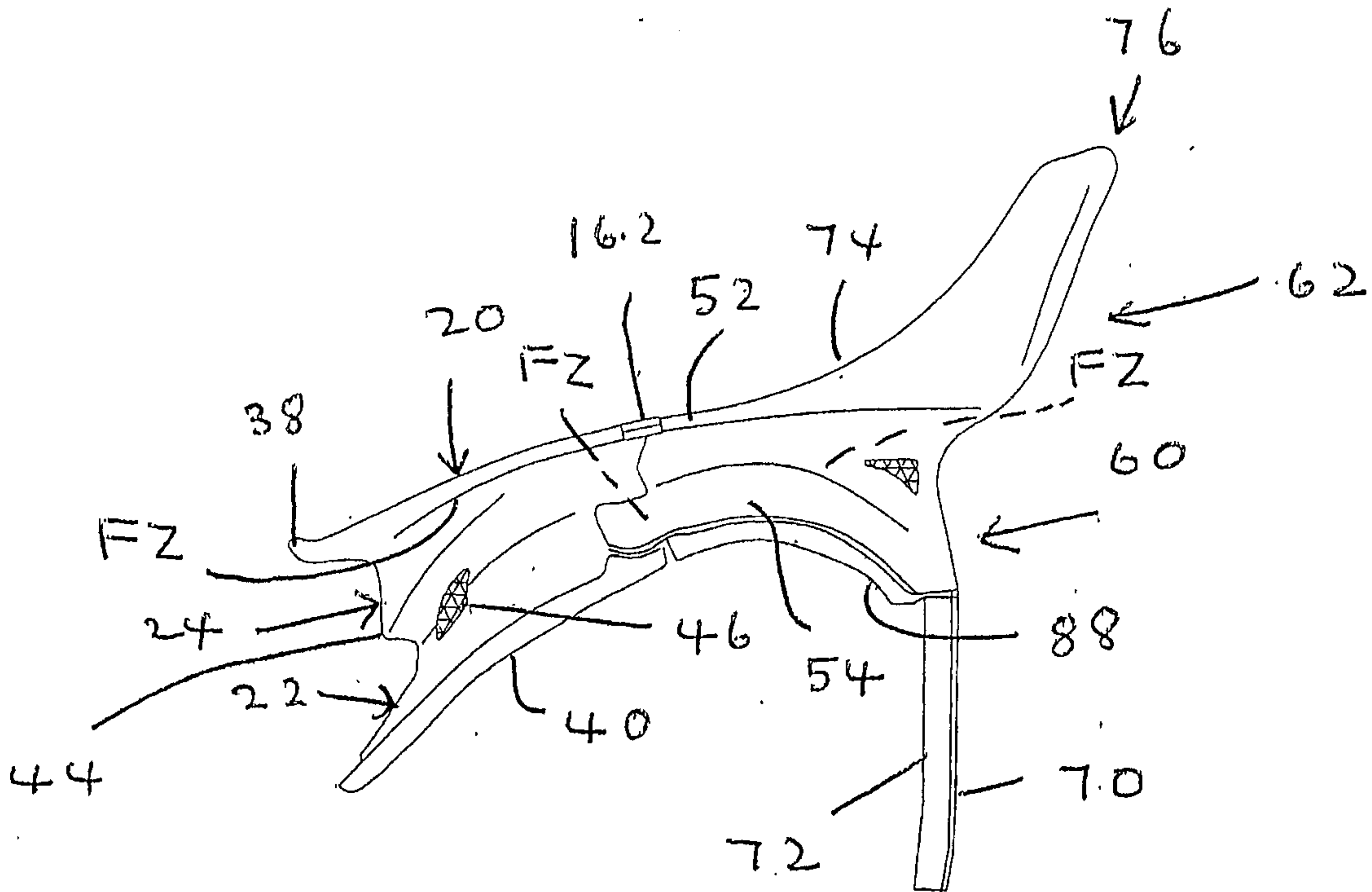

Fig. 6

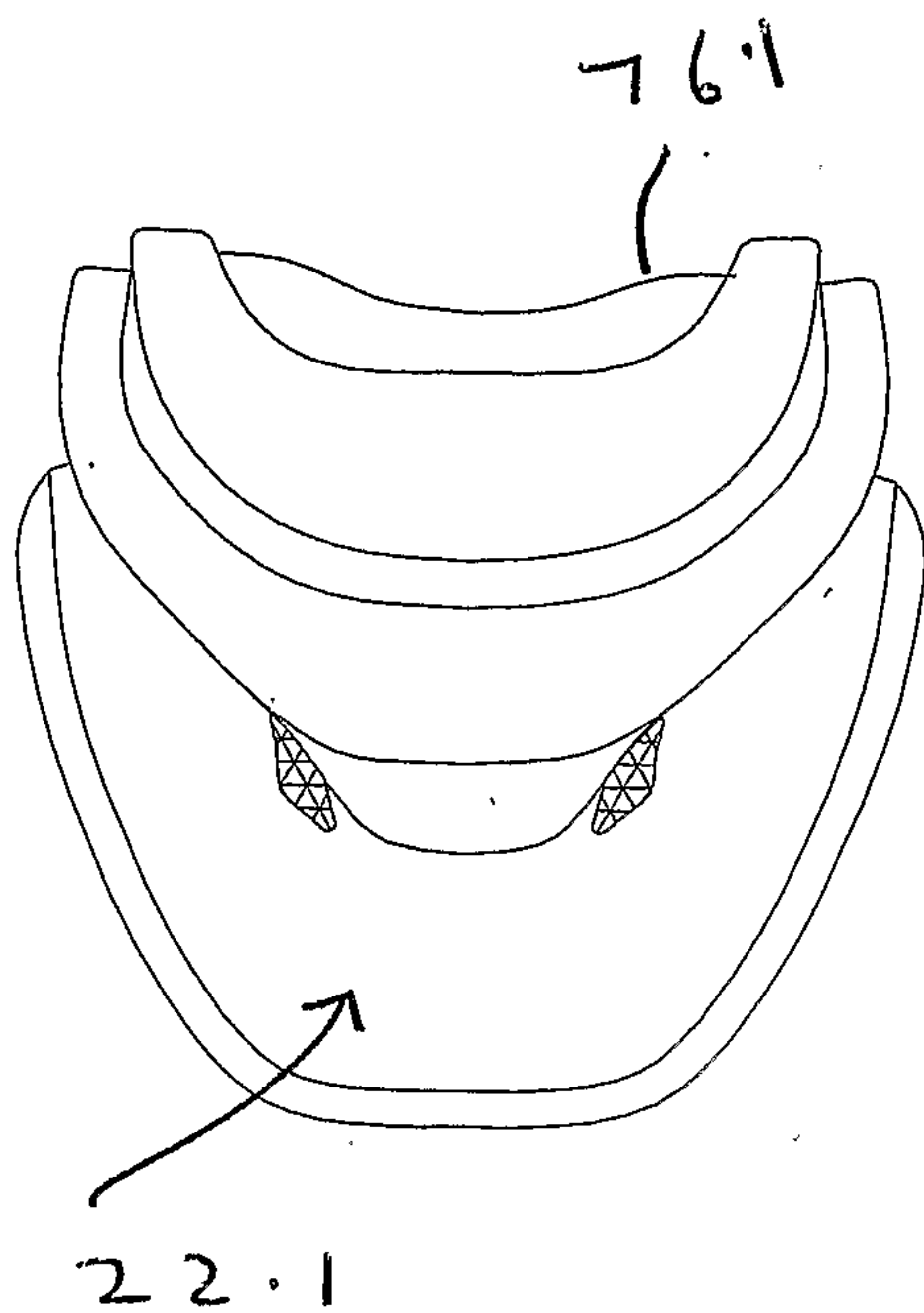

Fig. 7

4/6

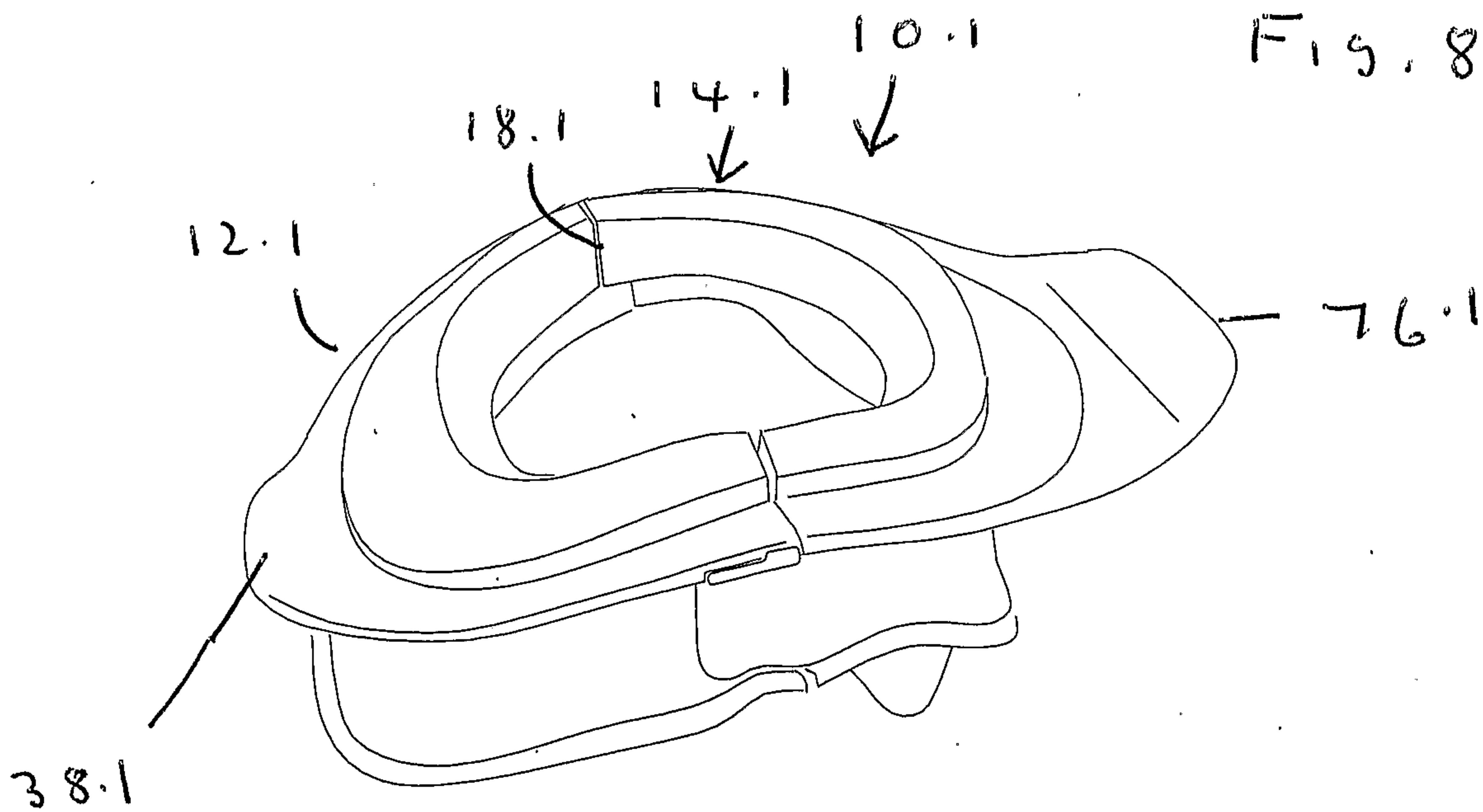

Fig. 8

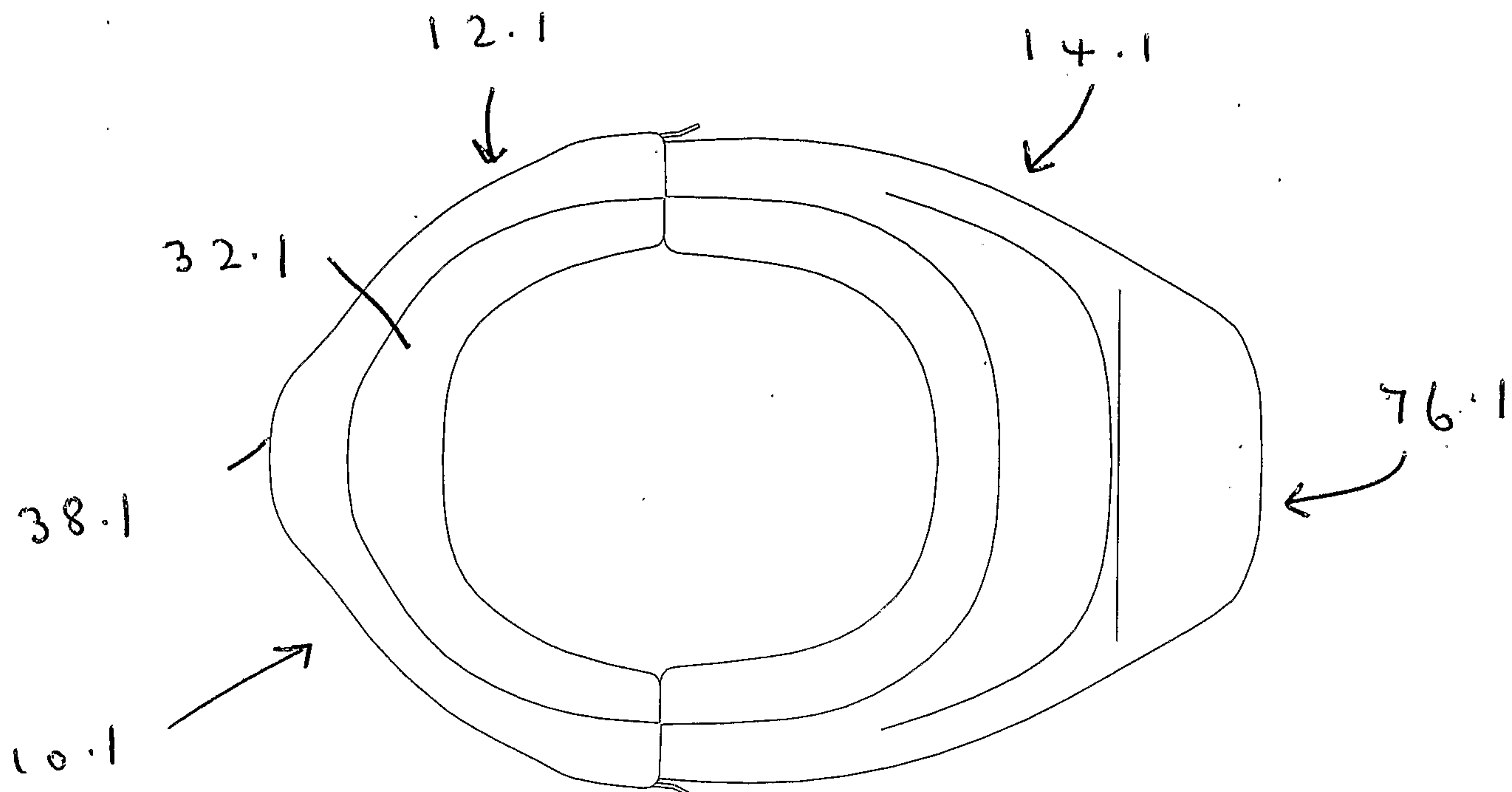

Fig. 9

5/6

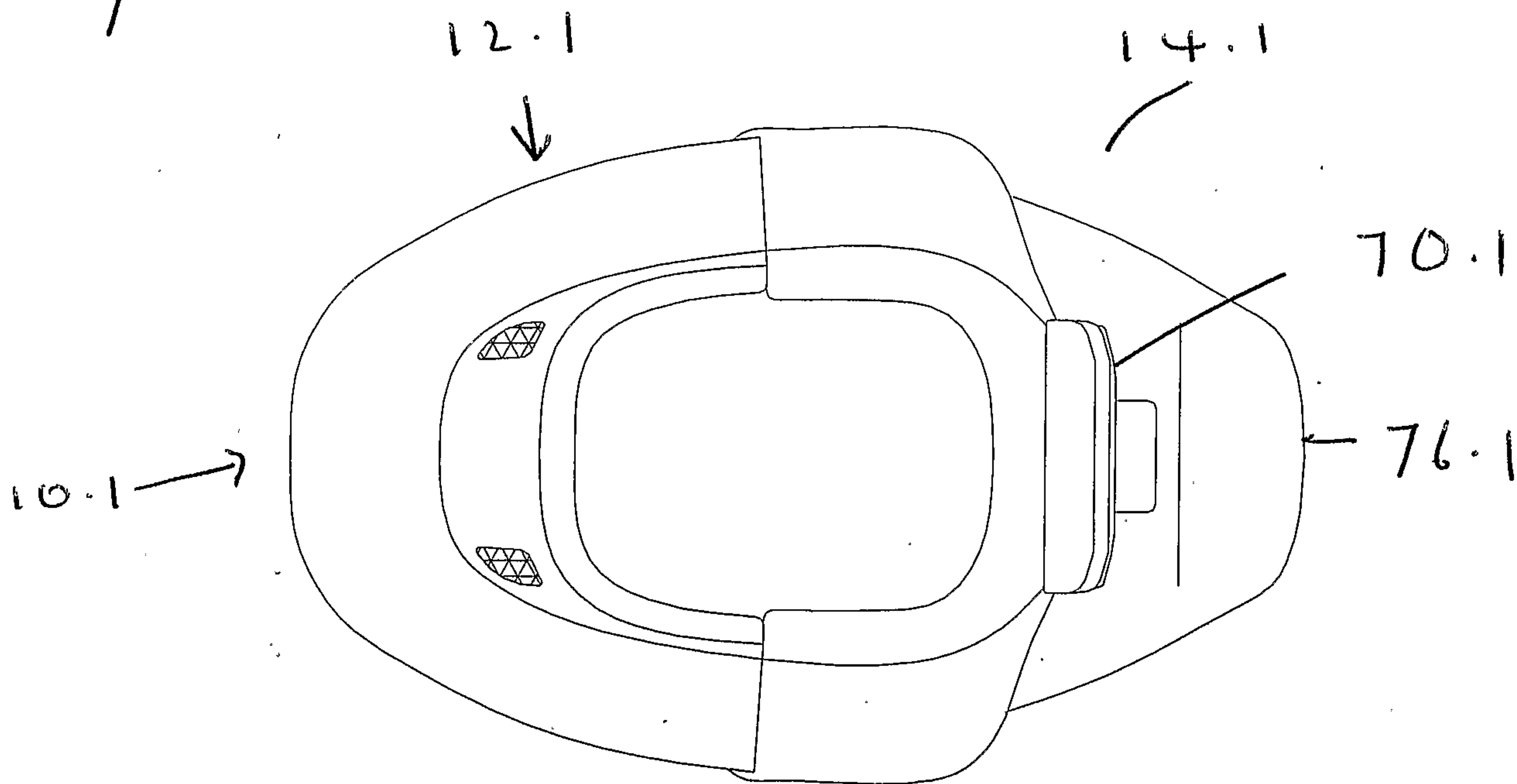

Fig. 10

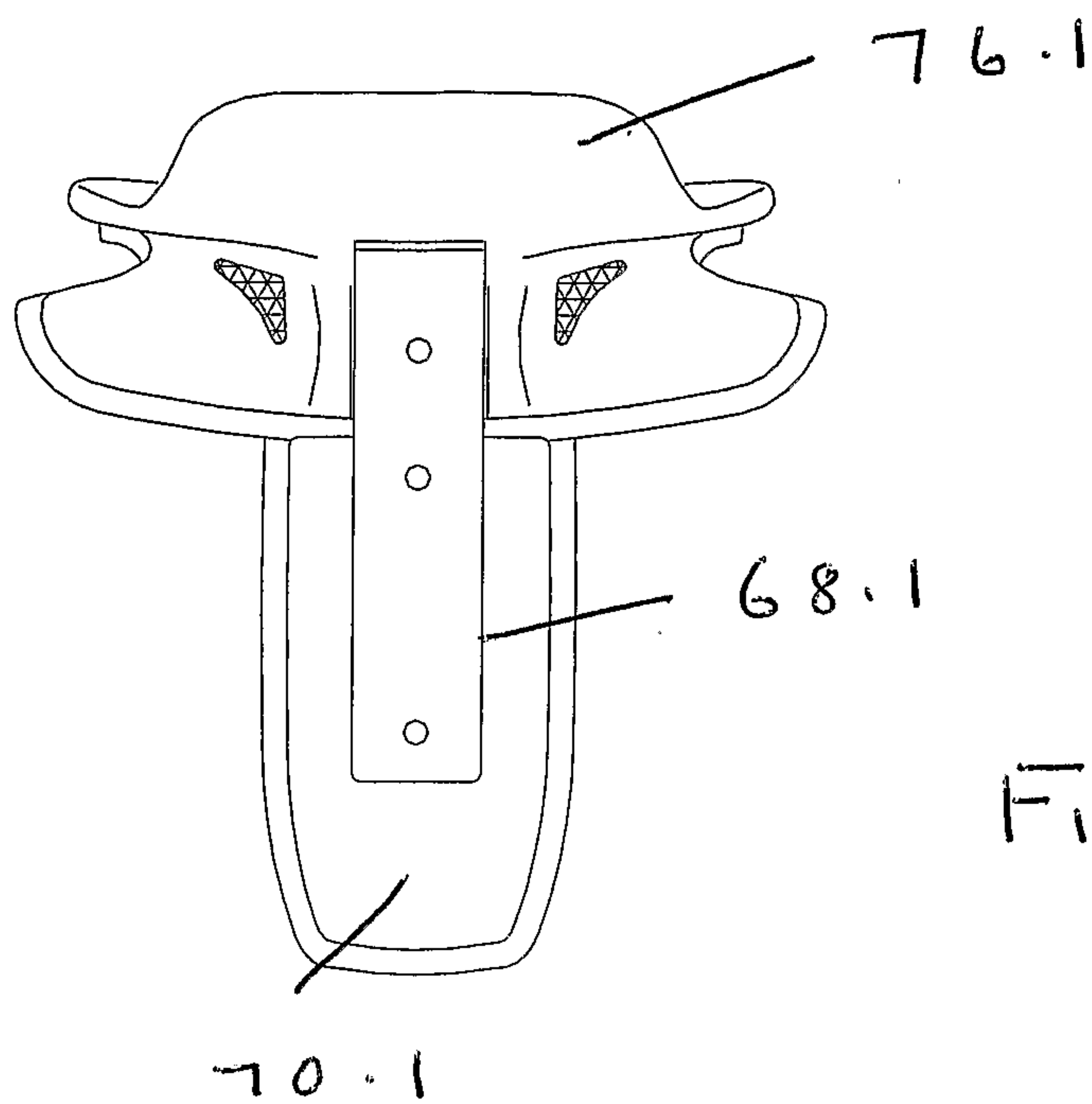

Fig. 11

6/6

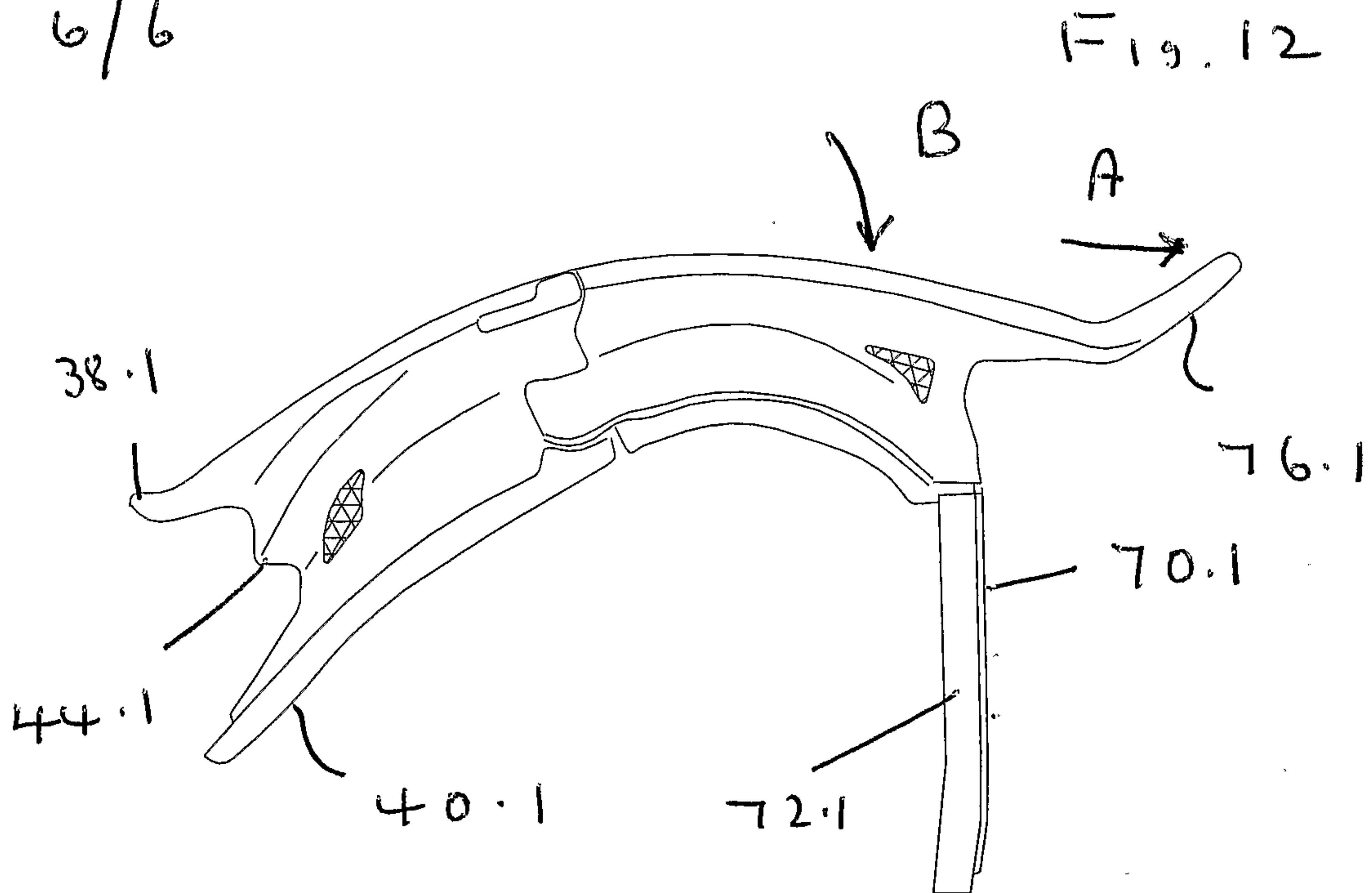

Fig. 12

