

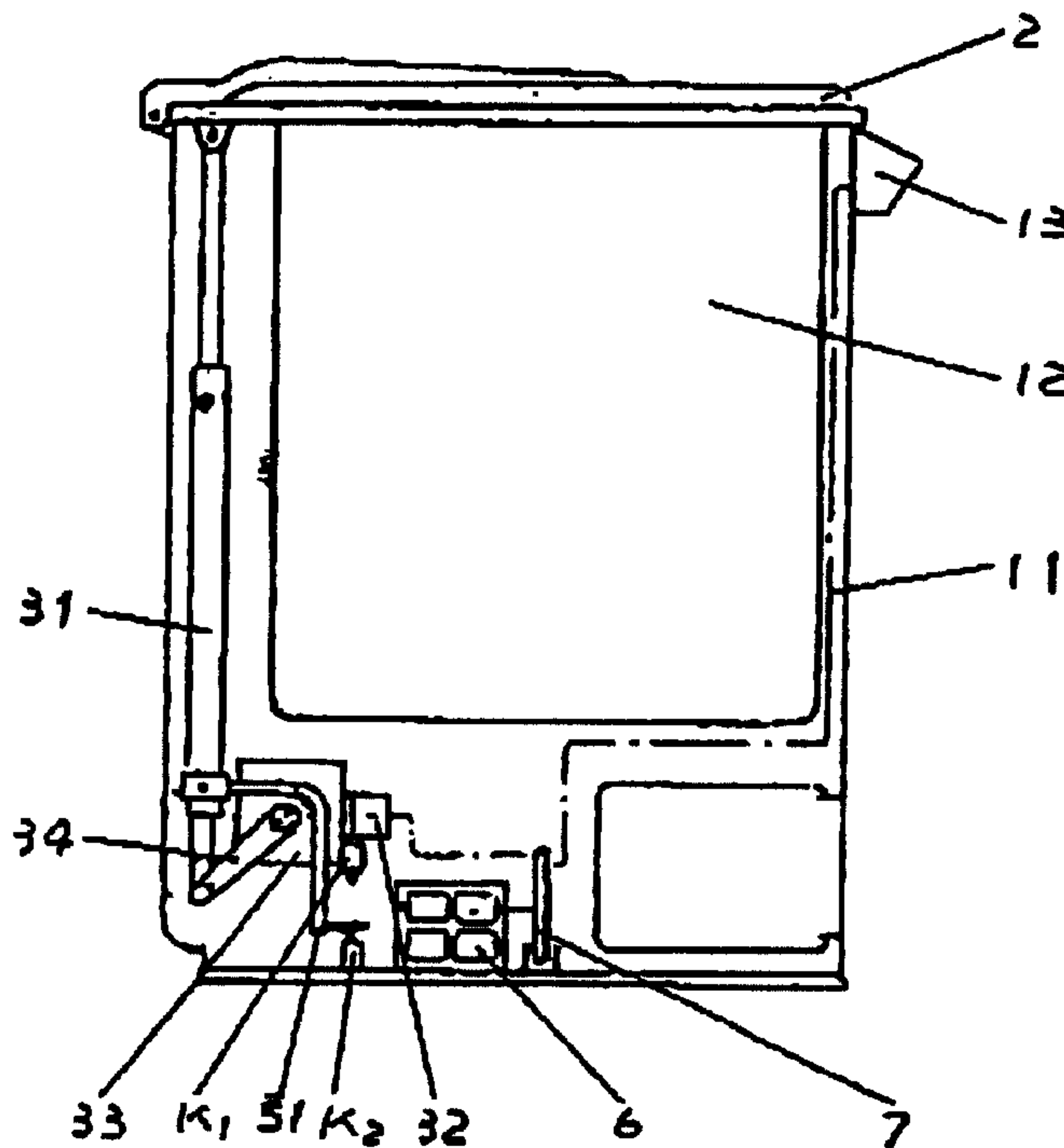

(86) Date de dépôt PCT/PCT Filing Date: 2000/05/23  
 (87) Date publication PCT/PCT Publication Date: 2001/08/30  
 (45) Date de délivrance/Issue Date: 2006/08/29  
 (85) Entrée phase nationale/National Entry: 2002/08/23  
 (86) N° demande PCT/PCT Application No.: CN 2000/000127  
 (87) N° publication PCT/PCT Publication No.: 2001/062617  
 (30) Priorité/Priority: 2000/02/26 (CN00 2 04125.1)

(51) Cl.Int./Int.Cl. *B65D 43/26* (2006.01),  
*B65F 1/16* (2006.01)  
 (72) Inventeurs/Inventors:  
WANG, XIN, CN;  
CHEN, WEN, CN  
 (73) Propriétaires/Owners:  
WANG, XIN, CN;  
CHEN, WEN, CN  
 (74) Agent: ROBIC

(54) Titre : CONTENEUR ACTIONNE PAR INDUCTION  
 (54) Title: AN INDUCTION ACTUATED CONTAINER



(57) **Abrégé/Abstract:**

The invention relates to an induction actuated container which includes a container body, a container cover, a drive means and an induction means. The drive means includes a driven operating member and a driving member. The induction means includes a sensor and an actuating controller for the driving member. One end of the driven operating member is transmissively connected with the container cover, the other end is transmissively connected with the driving member, and the sensor is electrically connected with the actuating controller for the driving member, and the actuating controller for the driving member is connected with a controlling end of the driving member. A signal caused by the approaching of a human or object is received by the sensor and is converted into an electrical signal. Then, the actuating controller for the driving member controls the driving member to perform a corresponding mechanical action.

## (12) 按照专利合作条约所公布的国际申请

(19) 世界知识产权组织  
国际局(43) 国际公布日:  
2001年8月30日(30.08.01)

PCT

(10) 国际公布号:  
WO 01/62617 A1

- (51) 国际分类号<sup>7</sup>: B65D 43/26, B65F 1/16
- (21) 国际申请号: PCT/CN00/00127
- (22) 国际申请日: 2000年5月23日(23.05.00)
- (25) 申请语言: 中文
- (26) 公布语言: 中文
- (30) 优先权:  
00204125.1 2000年2月26日(26.02.00) CN
- (71)(72) 发明人/申请人: 王昕(WANG, Xin) [CN/CN]; 中国福建省福州市台江区通太桥42号, Fujian 350000 (CN)。陈文(CHEN, Wen) [CN/CN]; 中国福建省福州市连江中路华林花园1号楼801室, Fujian 350011 (CN)。
- (74) 代理人: 中科专利商标代理有限责任公司(CHINA SCIENCE PATENT & TRADEMARK AGENT LTD); 中国北京市海淀区海淀路80号中科大厦16层, Beijing 100080 (CN)。
- (81) 指定国(国家): AM, AU, AZ, BR, BY, CA, CH, DE, DK, ES, FI, GB, GE, HU, IL, IS, JP, KP, KR, KZ, LR, LT, LU, MN, MX, NO, NZ, PT, RO, SE, SG, TR, UA, US, VN
- (84) 指定国(地区): 欧洲专利(AT, BE, CH, CY, DE, DK, ES, FI, FR, GB, GR, IE, IT, LU, MC, NL, PT, SE)
- 本国际公布:  
— 包括国际检索报告。  
— 包括经修改的权利要求。

所引用双字母代码和其它缩写符号, 请参考刊登在每期PCT公报期刊起始的“代码及缩写符号简要说明”。

(54) Title: AN INDUCTION ACTUATED CONTAINER

(54) 发明名称: 感应开启容器

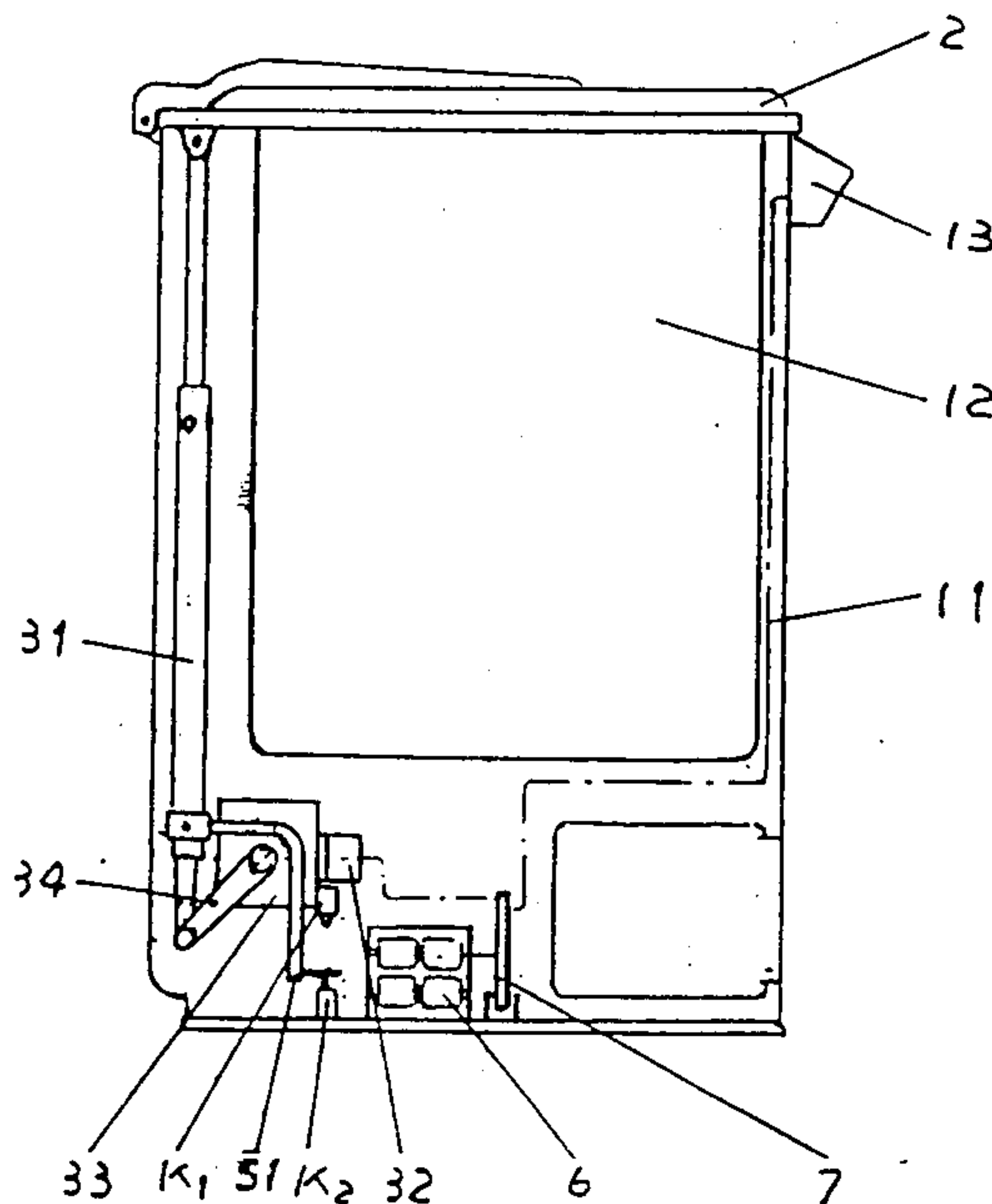

(57) **Abstract:** The invention relates to an induction actuated container which includes a container body, a container cover, a drive means and an induction means. The drive means includes a driven operating member and a driving member. The induction means includes a sensor and an actuating controller for the driving member. One end of the driven operating member is transmissively connected with the container cover, the other end is transmissively connected with the driving member, and the sensor is electrically connected with the actuating controller for the driving member, and the actuating controller for the driving member is connected with a controlling end of the driving member. A signal caused by the approaching of a human or object is received by the sensor and is converted into an electrical signal. Then, the actuating controller for the driving member controls the driving member to perform a corresponding mechanical action.

[见续页]



WO 01/62617 A1

## **An Induction Actuated Container**

### **Technical Field of the Invention**

The invention relates to a container with a cover, and more particularly to an induction-actuated container.

### **Description of the Related Art**

10 In prior art, containers with covers must be opened and closed manually. This creates inconvenience in operation. When the container is packed with special materials, such as rubbish or medical disposals, manual operation to the container cover will not only be inconvenient, but also have the risk of infection.

### **Summary of the Invention**

The object of the invention is to provide a convenient and hygiene induction actuated container so as to overcome the disadvantages of the prior art.

20 The object of the invention is realized through the following aspects.

According to the present invention, there is provided an induction actuated container having a container body, a container cover for covering the top opening of the container body and being hinged with one side of the container body, an induction means for detecting that human body or an object approaches the induction actuated container and a driving means for driving the container cover to open and close, wherein the induction means comprising:

a sensor for detecting when a human body or an object approaches the induction actuated container and generating a detecting signal, the sensor located in an induction window on the front side of the container body;

30 a filter shaping circuit for filtering and shaping the detecting signal; and

an actuating controller for receiving the detecting signal filtered and shaped from the filter shaping circuit and generating a triggering signal to the controlling end of a driving member, and the actuating controller having a delay circuit for delaying the period of the triggering signal to a predetermined time so as to control the container cover maintain an opening state during the predetermined time;

wherein the driving means comprising:

10 the driving member being installed at the bottom of the container body for generating a mechanical action based on the triggering signal delayed and output from the delaying circuit, and being connected with a driven operating member via a transmission part for driving the driven operating member; and

the driven operating member having a crown bar, the top end of the crown bar is hinged with the container cover, the hinging point between the top end of the crown bar and the container cover is apart from that between the container cover and the container body, and the bottom end of the crown bar is connected with the transmission part.

Preferably, the object of the invention could also be realized through the following features.

20 **Movements of the driven operating member and connections to the container cover can be the following modes:**

The container cover is hinged with one side of the container body; the driven operating member comprises a crown bar, the top end of the crown bar is hinged with the container cover, and the hinging point between the top end of the crown bar and the container cover is apart from that between the container cover and the container body. The up and down movement of the crown bar opens and closes the container cover respectively.

30 The driven operating member comprises a crown bar; the top end of the crown bar is connected with the container cover. The container cover in this arrangement only covers on the container without any connection. The up and down movement of the crown bar moves the cover up and down to realize its open and close action respectively.

The driven operating member comprises a rotating bar, the top end of the rotating bar is connected with the container cover at its side edge. The container cover in this arrangement also only covers on the container without any connection. When it is necessary, the rotating bar rotates to a certain angle to separate the container cover from the container to realize the open action of the container cover.

The drive member can be either a motor or an electromagnetic clutch, which provides with up and down movements.

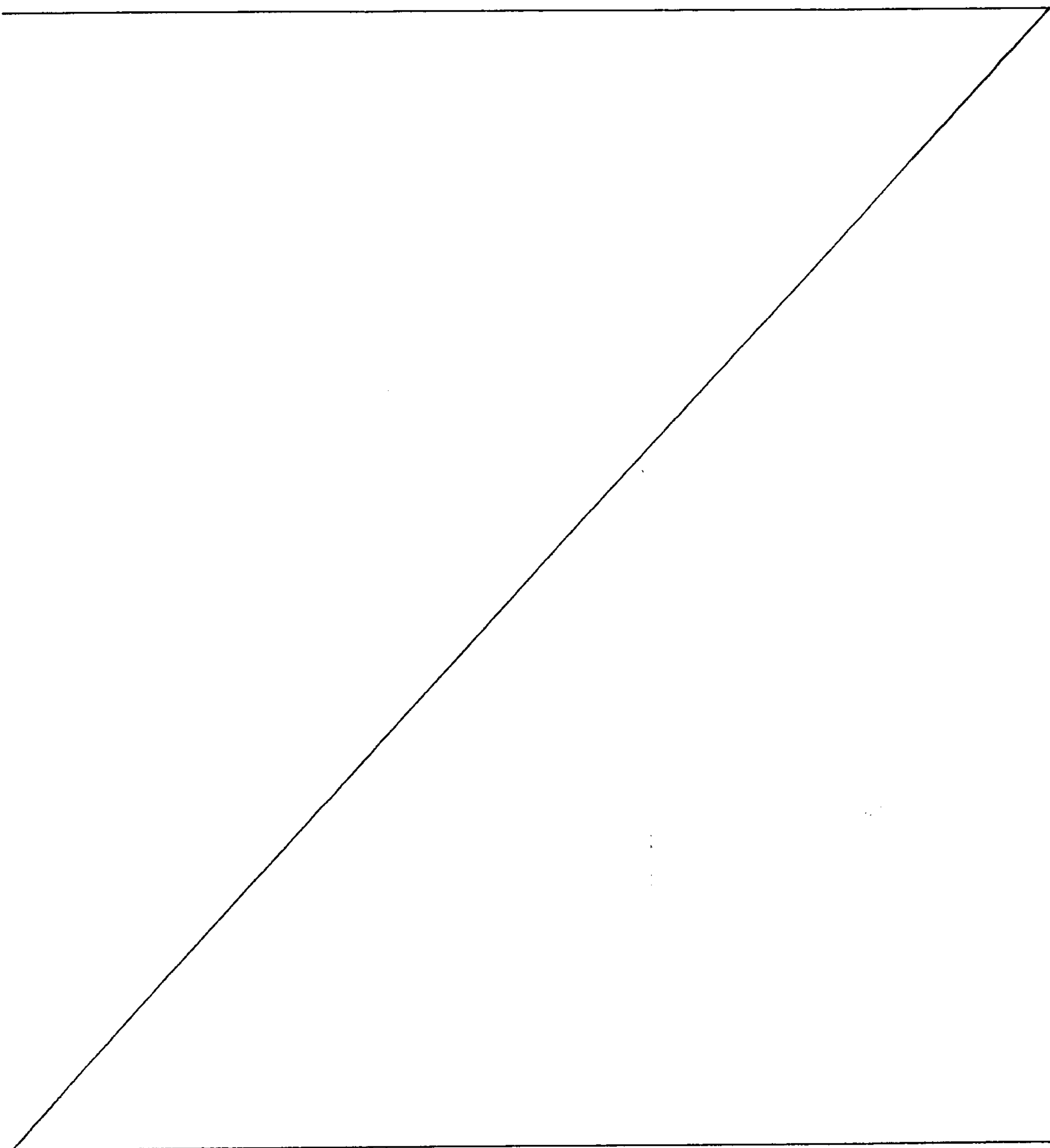

The open and close of the electromagnetic clutch make the crown bar move up and down.

The container body includes the outer body and the inner barrel. The inner barrel is sitted in the outer body.

The drive means and the induction means are generally installed on the outer body. The inner barrel is usually bare. When the container cover is open, the inner barrel could be moved out for the convenience of use.

There are several options to the induction means, especially to the sensor. Some of them are referred as below:

The sensor is an inductive oscillator; the induction means further comprising a filter shaping circuit, the actuating controller for driving member comprising a monostable trigger; the filter shaping circuit is connected between the sensor and the monostable trigger; the monostable trigger is connected to the actuating controller for the driving member; the approaching of an object or human body will change the oscillating frequency of the inductive oscillator, the signal output the inductive oscillator is first filtered and shaped, and then goes through the monostable trigger and the actuating controller for the driving member to make the driving member to perform corresponding mechanical action.

The sensor is a microwave probe, the induction means further comprising an amplifying comparator, and the actuating controller for the driving member further comprising a monostable trigger and a driving circuit; the amplifying comparator is connected between the microwave probe and the monostable trigger; when there is relative radial movement between the transmitted microwave signal and the being measured active object, the signal reflected from the being measured active object will have frequency shift, as a frequency shift signal, the frequency shift signal is amplified and compared by the amplifying comparator; the amplifying comparator then sends out a triggering signal to the monostable trigger and driving circuit to make the driving member to perform corresponding mechanical action.

The sensor comprises an infrared transmitter and an infrared receiver; the induction means further comprising an amplifying comparator, and the

actuating controller for the driving member comprising a monostable trigger and a driving circuit; the amplifying comparator is connected between the infrared receiver and the monostable trigger; the infrared receiver receives the signal reflected from human body or object, the amplifying comparator amplifies the received signal and compares with a reference value so that making a judgment, and sends out a triggering signal to the monostable trigger and driving circuit if necessary to make the driving member to perform corresponding mechanical action.

Further, it is preferably comprising a limit means. The limit means has an upper and a lower travel switches and triggering bar; upper and lower travel switches are arranged opposite to each other and mounted to the container body; one end of the triggering bar is connected to the driven operating member; another end is connected between the upper travel switch and the lower travel switch; and the limit means is mounted on the container body.

As a result, as compared with the prior art, the invention has the following advantages: Container cover automatically opens when human body or an object approaches without any direct body contacts. This is not only convenient in use, but also releases people from worries of body contacts with the containers. The invention is especially suitable for the containers for rubbish, medical apparatus, or food.

### **Brief Description of the Drawings**

The above and other objects, advantages, and features of the present invention will be more apparent from the following description taken in conjunction with the accompanying drawings in which:

Fig. 1 is a schematic diagram showing configurations of an induction-actuated container according to the first embodiment of the invention.

Fig. 2 is a block diagram showing the operating principle of the induction means used in the induction-actuated container according to the first embodiment of the invention.

Fig. 3 is a circuit diagram of the induction means used in the induction-

actuated container according to the first embodiment of the invention.

Fig. 4 is a schematic diagram showing configurations of an induction-actuated container according to second embodiment of the invention.

Fig. 5 is a block diagram showing the operating principle of the induction means used in the induction-actuated container according to the second embodiment of the invention.

10 Fig. 6 is a circuit diagram of the induction means used in the induction-actuated container according to the second embodiment of the invention.

### Detailed Description of the Preferred Embodiments

#### First Embodiment

Referring to Fig. 1, the induction-actuated container consists of a container body , container cover 2, drive means, and induction means. The container body includes an outer body 11 and an inner barrel 12. The inner barrel 12 is sat in the outer body 11. The driver means includes a driven operating member 31 and a drive member 32. The driven operating member is a crown bar, which is hinged at the top thereof with the container cover 2. The hinging connection point between the crown bar and the container cover is apart from the hinging point between the container cover 2 and container body and located at the inner side of the hinging point. The drive member 32 is an electromagnetic clutch comprising an electromagnet. The lower part of the crown bar is plugged through the core cavity of the electromagnetic and connected with a magnet. Sensor of the induction means is mounted in the induction window 13. The induction window 13 is located at the upper part of the side wall of the container outer body 11. Other components of the induction means (including battery set 6 and circuit 7) are mounted in the lower part of the container outer body 11.

Referring to Fig. 2, the induction means consists of a sensor 41, a filter shaping circuit 43, and an actuating controller 42 for the driving member. The

actuating controller 42 for the driving member includes a monostable trigger 421 and a driving circuit 422. The filter shaping circuit 43 is connected between the sensor and the monostable trigger 421, and the monostable trigger 421 is electrically connected to the drive member 32 via the driving circuit 422.

Referring to Fig. 3, the sensor 41 is an inductive oscillator, which consists of a triple point capacitor type oscillator by a transistor Q1, capacitors C1 to C3 and an inductance L1, and an induction board M. One end of the induction board M is connected to the inductance L1. There is a distributive capacitor C0 between the induction board M and grounding. The parameters of the distributive capacitor C0 are changed with the approaching of human body. The emitter of the transistor Q1 is connected with resistor R3, capacitor C4 and the base of transistor Q6. The collector of the transistor Q6 is connected with the base of transistor Q7. The collector of the transistor Q7 is connected with pin 9 of the NAND gate 74LS24. Capacitor C8 is connected between pin 9 of NAND gate 74LS24 and pin 3 of phase inverter 74HC14. Pin 3 of the phase inverter 74HC14 is also connected with diode D4 and resistor R10. The monostable trigger 421 is consisted by NAND gate 74LS24, inverter 74HC14, capacitor C8, diode D4, and resistor R10. Pin 4 of the inverter 74HC14 is connected with the base of transistor Q2 via resistor R7. The emitter of transistor Q2 is connected with power supply V. The collector of transistor Q2 is connected with the connector of electromagnetic clutch.

The operation principle of this embodiment is explained as follows.

When human body approaches to the induction board M, the voltage of the high frequency signal at both ends of the distributive capacitor C0 is decreased. Positive feedback voltage to the base of transistor Q1 via capacitor C3 is not enough to maintain continuous oscillation of the transistor Q1. So oscillation of transistor Q1 is stopped, so that the current pass through resistor R3 is decreased. Transistor Q6 is turned off, while transistor Q7 is turned on. Collector of transistor Q7 outputs a low level to trigger the monostable trigger 421 to output a low level for a certain interval (about 4 to 6 seconds). Meanwhile transistor Q2 is turned on to make

the electromagnet in the electromagnetic clutch to move the crown bar upward to open the container cover. After about 4 to 6 seconds, the electrical supply to the electromagnet is stopped. Then the container cover is fallen and closed with its own weight and the weight of the crown bar.

The same portions as those of the prior art are omitted here.

### **Second Embodiment**

Referring to Fig. 4, the induction-actuated container consists of a container body, a container cover 2, a drive means, and induction means, and a limit device. The drive means includes a driven operating member 31, a gear change mechanism 33 and a drive member 32. The driven operating member 31 is a crown bar, which is connected to a crank 34 at the lower end. The other end of the crank is connected to the output shaft of the gear change mechanism 33. The gear change mechanism 33 is transmissively connected to the output shaft of the motor, which forms the drive member 32. The limit device includes an upper travel switch K1, a lower travel switch K2 and a trigger bar 51. The upper and lower switches are mounted opposite to each other and fixed at the bottom of outer body 11 of the container. One end of the trigger bar is connected to the crown bar; the other end is plugged between of the upper travel switch K1 and the lower travel switch K2.

Referring to Fig. 5, the induction means consists of a sensor 41, an amplifying comparator 44 and an actuating controller 42 for the driving member. The actuating controller 42 for the driving member includes a monostable trigger 421, a driving circuit 422, and a rotating controller 423 of the drive member. The amplifying comparator 44 is connected between the sensor 41 and the monostable trigger 421. The monostable trigger first is electrically connected with the buck-boost rotating controller 423 of the drive member, then connected with the driving circuit 422. The base circuit 45 is connected with amplifying comparator 44.

Referring to Fig. 6, the sensor 41 consists of an infrared transmitter and an infrared receiver. Two units (IC1A and IC1B) of a hexad-inverter CD4069, resistors R3 and R4, diode D5 and capacitor C1 forms the narrow pulse oscillating circuit. The shaping and amplifying circuit is formed by the of the unit IC2A of the hexad-inverter 74HC14 and the transistor Q1, and

connected with the infrared LED D1. The infrared receiver is mainly consisted of the infrared detection diode D2. There are two amplifiers in the amplifying comparator 44. The comparator is consisted by unit IC4A and unit IC4B of the operational amplifier LM324, peripheral capacitors C2 to C6, and resistors R5 to R8. The infrared detection diode D2 is connected with the negative terminal (-) of unit IC4A via capacitor C2. Capacitor C4 is connected between the output terminal of unit IC4A and the negative terminal of unit IC3B. The output end of unit IC4B is connected to diode D3 via capacitor C6. Diode D3 is connected to capacitor C7, resistor R9, and the negative terminal of unit IC4C from operational amplifier LM324. The comparator of the amplifying comparator 44 is consisted of unit IC4C, diode D3, capacitor C7 and resistor R9. Varistor W1 is connected with the positive terminal (+) of unit IC4C to provide a reference voltage. The monostable trigger 421 is formed by the unit IC3C of NAND gate 74LS24, unit IC2B of hexad-inverter 74HC14, capacitor C8, diode D4 and resistor R10. Capacitor C8 is connected cross unit IC3C and unit IC2B, and is separately connected with diode D4 and resistor R10. Unit IC2B is connected with unit IC2D, and IC3C is connected with IC3B. The rotating controller 423 of the drive member is formed by the units IC2C, IC2D and IC2E of hexad-inverter 7p4LS24, travel switches K1 and K2, and resistors R11 and R12. The unit IC3A is connected to resistor R11 and travel switch K1; Unit IC3B is connected to resistor R12 and travel switch K2; Unit IC2E is connected to the base electrode of transistor Q2 via resistor R13; Unit IC2C is connected to the base of transistor Q3 via resistor R14; Collector of transistor Q2 is separately connected to the collector of transistor Q4 and the positive terminal (+) of a motor; Collector of transistor Q3 is separately connected to the collector of transistor Q5 and the negative terminal (-) of the motor. The driving circuit 422 is formed by the transistors Q2 to Q5 and resistors R13 to R18.

In this embodiment, only two units, IC1A and IC1B, of the hexad-inverter are used. Only five units, IC2A to IC2E, of hexad-inverter 74HC14 of the Schmidt trigger type are used. Only two units, IC3A and IC3B, quad-NAND gate 74LS24 of the Schmidt trigger type, in which each NAND gate has two input terminals, are used. Only three units, IC4A to IC4C, of the operational amplifier LM324 are used.

Operation principle of this embodiment is explained as follows:

Narrow pulse oscillating signal is transmitted by the infrared LED D1 after shaping and amplifying. When there is an approach of human body or an object to the upper part of the induction window 13 equipped with an infrared LED and an infrared detection diode, the infrared signal reflected is inverted into electrical pulse signal after the receiving of the infrared detection diode D2. The signal is sent to the comparator after amplification to compare with the reference voltage. When the amplitude of the amplified signal is higher than the reference voltage, output end of unit IC4C (pin 8 of LM324) is switched from the high level to the low level. The low level then triggers the monostable trigger 421 to make the output end of unit IC2B (pin 4 of 74HC14) send out the low level for a certain interval (about 4 to 6 seconds). The interval depends on the parameters of capacitor C8 and resistor R10.

If the container cover is closed, the upper travel switch is turned off, and the lower travel switch is turned on. The low level makes the output end of unit IC2E (pin 10 of 74HC14) produce a high level and the output end of unit IC2C (pin 6 of 74HC14) produce low level via the operation of the rotating controller 423 of the drive member. These two signals are applied to transistors Q2 and Q5 so that they are turned on, and transistors Q3 and Q4 are turned off. Reverse rotating voltage is applied to the motor terminal to make the motor to rotate reversely to lift the crown bar upward to open the container cover 2.

When the container cover is opened to a limit position, the upper travel switch K1 is turned on and the lower travel switch is turned off. The output ends of unit IC2E (pin 10 of 74HC14) and unit IC2C (pin 6 of 74HC14) are low level. The driving circuit 422 is not functioning and the motor is not energized to keep the container cover 2 at the highest position. When the delay signal interval of the monostable trigger 421 ends, output end of unit IC2B (pin 4 of 74HC14) is switched to high level to make the output ends of unit IC2E (pin 10 of 74HC14) and unit IC2C (pin 6 of 74HC14) become low level and high level respectively. The driving circuit 422, transistors Q3 and Q4 are turned on, transistors Q2 and Q5 are turned off. Forward voltage is applied to the motor to move the crown bar downward to close the container cover 2 gradually.

When the cover is closed to its position, the lower travel switch is turned on to make the output end of unit IC2C (pin 6 of 74HC14) is switched to low level. Transistors Q2 to Q5 are turned off and the motor is not energized. The whole circuit is ready for the next operation cycle. The same portions as those of the first embodiment are omitted in this embodiment for simplifying the description.

**WHAT IS CLAIMED IS:**

1. An induction actuated container having a container body, a container cover for covering the top opening of the container body and being hinged with one side of the container body, an induction means for detecting that human body or an object approaches the induction actuated container and a driving means for driving the container cover to open and close, wherein the induction means comprising:

10 a sensor for detecting when a human body or an object approaches the induction actuated container and generating a detecting signal, the sensor located in an induction window on the front side of the container body;

a filter shaping circuit for filtering and shaping the detecting signal; and

an actuating controller for receiving the detecting signal filtered and shaped from the filter shaping circuit and generating a triggering signal to the controlling end of a driving member, and the actuating controller having a delay circuit for delaying the period of the triggering signal to a predetermined time so as to control the container cover maintain an opening state during the predetermined time;

wherein the driving means comprising:

20 the driving member being installed at the bottom of the container body for generating a mechanical action based on the triggering signal delayed and output from the delaying circuit, and being connected with a driven operating member via a transmission part for driving the driven operating member; and

the driven operating member having a crown bar, the top end of the crown bar is hinged with the container cover, the hinging point between the top end of the crown bar and the container cover is apart from that between the container cover and the container body, and the bottom end of the crown bar is connected with the transmission part.

2. The induction actuated container according to claim 1, wherein the drive member could be either a motor or an electromagnetic clutch, which provides with up and down movements.

3. The induction actuated container according to claim 1, wherein the container body comprising an outer body having a up opening and an inner barrel, which is sitten in the outer body.

4. The induction actuated container according to claim 1, wherein the delaying circuit is a monostable trigger.

5. The induction actuated container according to claim 1 or 4, wherein  
10 the sensor is an inductive oscillator.

6. The induction actuated container according to claim 1 or 4, wherein the sensor is a microwave probe.

7. The induction actuated container according to claim 1 or 4, wherein the sensor comprising an infrared transmitter and an infrared receiver.

8. The induction actuated container according to claim 1 or 4, wherein further comprising: a limit means located at the bottom of the container body; the limit means having an upper and a lower travel switches (K1 and K2) and triggering bar; upper and lower travel switches (K1 and K2) are arranged  
opposite to each other and mounted to the container body; one end of the  
20 triggering bar is connected to the driven operating member; another end is connected between the upper travel switch and the lower travel switch (K1 and K2).

1/3

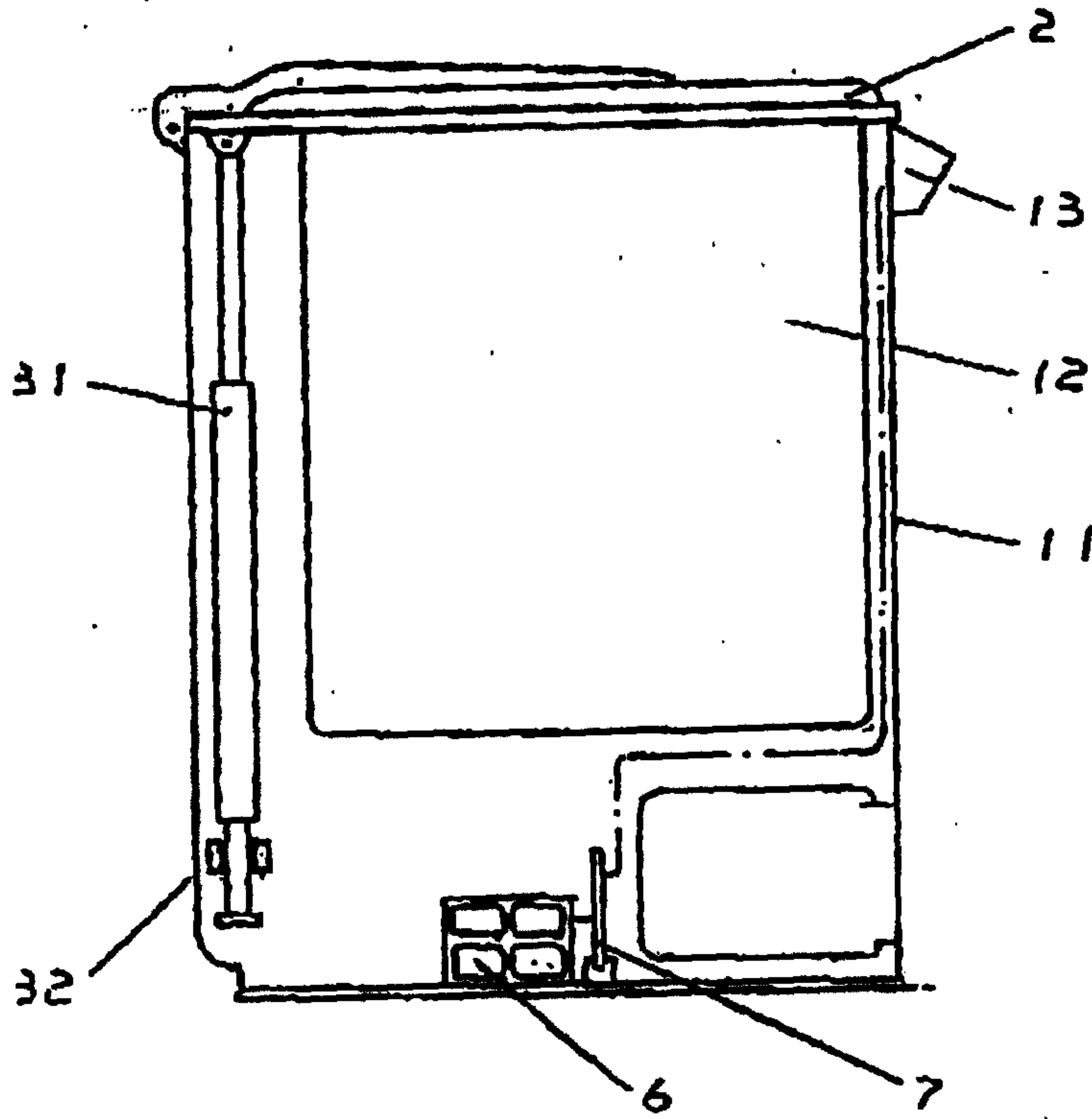

Fig.1

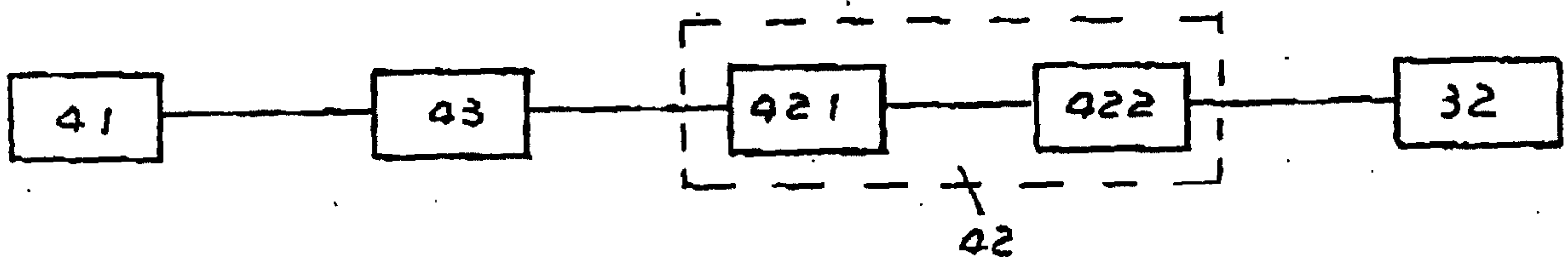

Fig.2

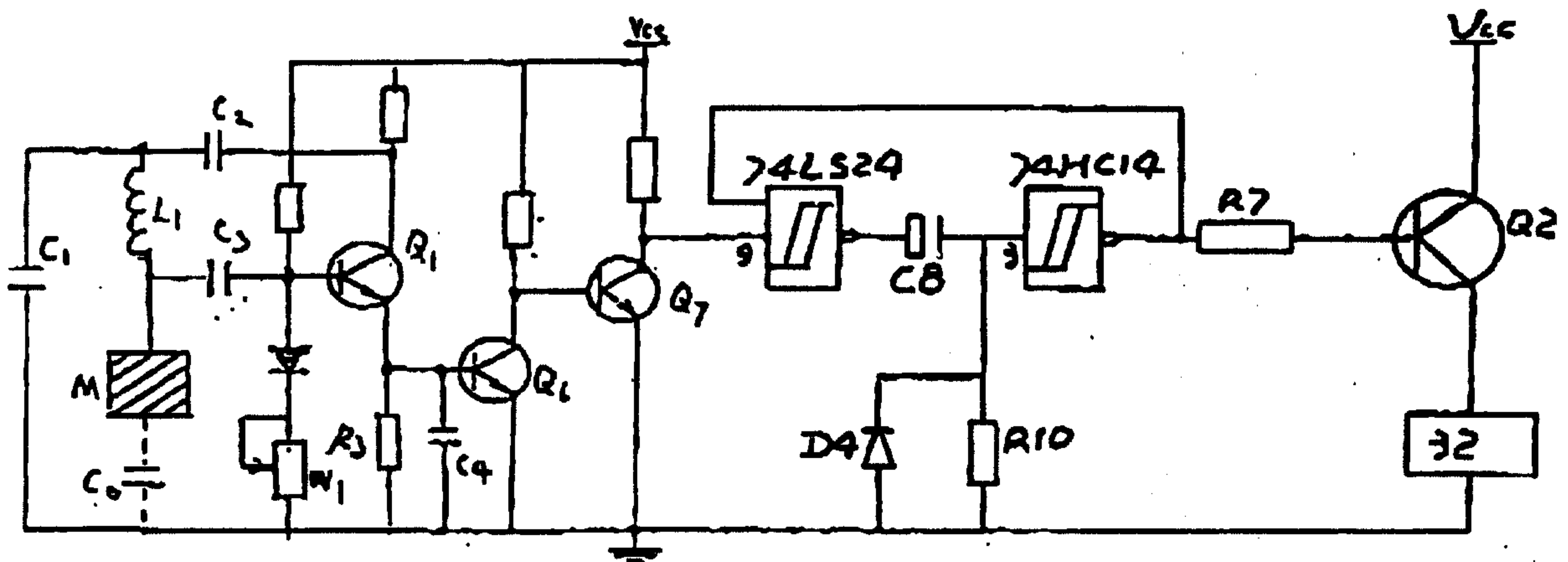

Fig.3

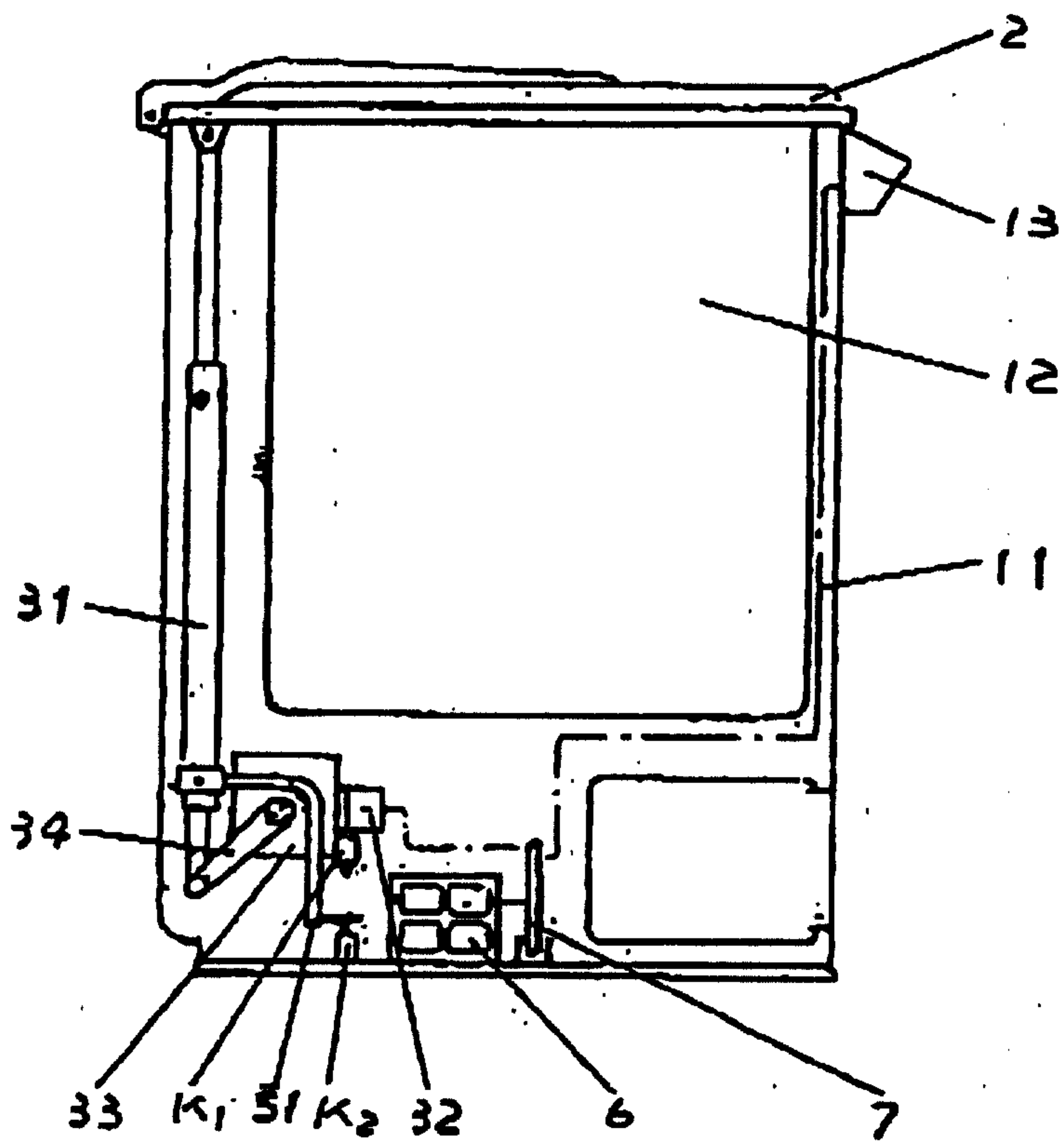

Fig.4



