

J. R. Lee,

Hydro Carbon Burner.

No. 112358.

Patented Mar. 7. 1871.

Fig. 1.

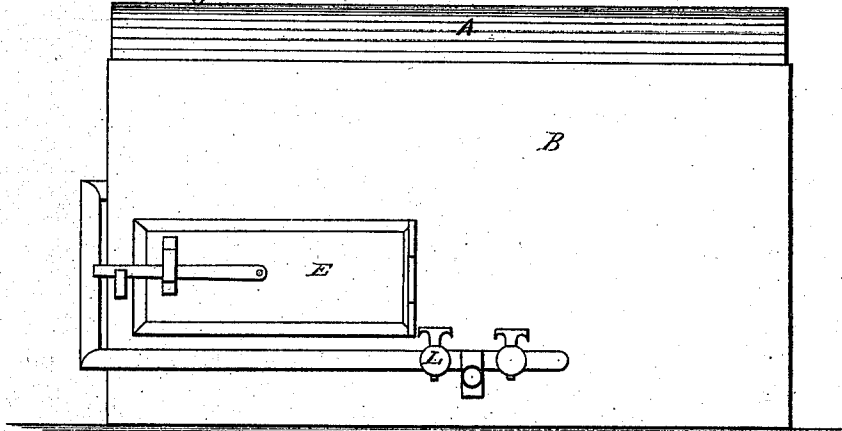

Fig. 4.

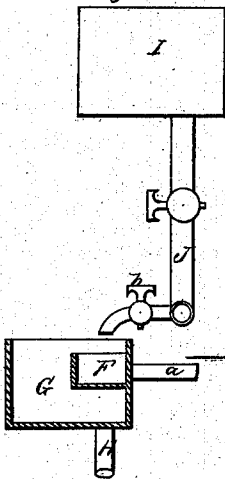

Fig. 2.

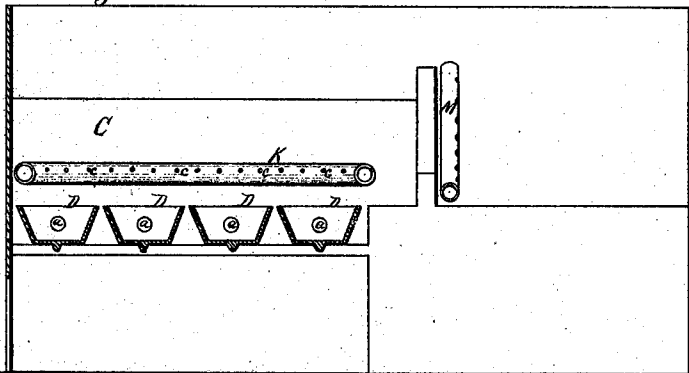
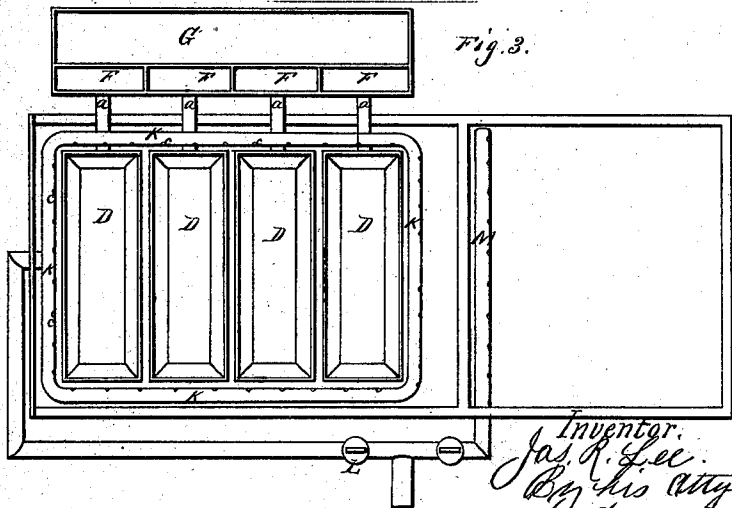

Fig. 3.



Witnesses:
Geo. H. Strong
Chas. Crowder

Inventor:
Jas. R. Lee
By Geo. H. Strong
S. Sewell

United States Patent Office.

JAMES R. LEE, OF GRASS VALLEY, CALIFORNIA.

Letters Patent No. 112,358, dated March 7, 1871.

IMPROVEMENT IN APPARATUS FOR BURNING HYDROCARBON OILS.

The Schedule referred to in these Letters Patent and making part of the same.

To all whom it may concern:

Be it known that I, JAMES R. LEE, of Grass Valley, county of Nevada, State of California, have invented an Improvement in the Combustion of Hydrocarbon Oils; and I do hereby declare the following description and accompanying drawing are sufficient to enable any person skilled in the art or science to which it most nearly appertains to make and use my said invention or improvement without further invention or experiment.

The object of my invention is to provide a device by which a more perfect combustion of hydrocarbon oils is secured when they are employed in the furnaces of steam-boilers, and also the employment and utilization of exhaust steam within the furnace to assist and promote such combustion.

It consists in the use of a series of shallow troughs, placed preferably in a transverse position in the furnace.

Into these troughs the oil is fed so as to have little depth, and is burned from them.

A pipe or series of pipes arranged around the interior of the furnace receives a portion of the exhaust steam, and throws it into the fire in fire-jets, so as to mingle with it as thoroughly as possible, and by its decomposition to supply oxygen.

A branch of the exhaust-pipe is carried in behind the bridge-wall, and is so perforated that the jets of steam issuing from it serve to increase the draught, as may be desired.

Referring to the accompanying drawing for a more complete explanation of my invention—

A is a boiler, set in brick-work B, having the ordinary fire-box C.

Within this fire-box or furnace a number of shallow iron pans, D, is placed transversely, being introduced or removed at pleasure through a side door, E.

The sides of these pans are made quite flaring, or so as to stand at a considerable angle with the bottom, this construction allowing the flame free access, so that the residual tar can also be burned.

The petroleum or other hydrocarbon oil to be used is fed into the pans through pipes *a*, and is intended to stand at a small depth, about one-fourth of an inch.

In order to regulate this the pipes *a* are connected with a series of boxes, F, which are themselves placed within a larger box or tank, G.

The inner edges of the boxes F are made of such a height that any surplus oil beyond what is necessary for the pans will flow over the edge into the tank G, from which it flows by a pipe, H, back to the general supply-tank.

This latter tank may be placed at any convenient point, and the oil may be pumped from it into a tank, I.

From the tank the oil flows by supply-pipes J to the boxes F, and is regulated by cocks *b*.

The pipes *a* are so constructed with the boxes F that they can be easily uncoupled, and the pans D can be easily removed for repairs or cleaning.

Any number of pans can be used, and the fire is regulated by shutting off the oil from one or more.

If found desirable, one or more rows of pieces of charcoal, set on end, may be employed to give a greater burning surface, serving as wicks to draw the oil up by capillary attraction.

In order to increase the combustion and give a more intense heat, as well as to economize steam, the exhaust steam from the engine is allowed to enter a pipe, K, or a series of pipes, as may be found best.

These pipes extend around the interior of the fire-box, and are perforated by numerous small jet-holes *c c*, from which the steam, superheated by the pipes, issues, being directed toward the center from all sides except the rear, and so finely divided as to mingle thoroughly with the flame. By its decomposition it furnishes the elements, oxygen and hydrogen, which greatly increase the heat of the fire, and change it from a red smoky blaze to a white one, with almost no smoke at all.

On the rear side the perforations are so arranged as to direct the steam backward, and thus, by creating a partial vacuum, to cause the flame to tend in that direction.

The amount of steam admitted to this part of the furnace can be regulated by a stop-cock, L.

The remainder of the exhaust steam, or such portion of it as may be desired, is carried into a pipe, M, just behind the bridge-wall, and issues through perforations into that part of the furnace, being directed toward the back part, and thus increasing the draught, as well as employing more oxygen and hydrogen to unite with any unconsumed carbon flame which may pass over the wall.

If found necessary the draught may be increased, when the fire is first started, by introducing air to the pipe K by bellows or other suitable device.

The use of steam as described above, although necessary to the perfect combustion of hydrocarbon oils, is not confined to those furnaces, as it may be used with good effect in coal and other furnaces.

Having thus described my invention,

What I claim as new, and desire to secure by Letters Patent, is—

1. The independent pans D, with their supply-tubes *a*, and the regulating-boxes F, constructed and operating substantially as and for the purpose herein described.

2. The perforated pipe K, placed in the furnace as shown, with the perforations on the rear side so arranged as to direct the steam backward, and thus, by creating a partial vacuum, to cause the flame to

tend in that direction, substantially as and for the purpose set forth.

In witness that the above-described invention is claimed by me I have hereunto set my hand and seal.

Witnesses: JAMES R. LEE. [L. S.]
CHAS. BROWN,
GEO. H. STRONG.