

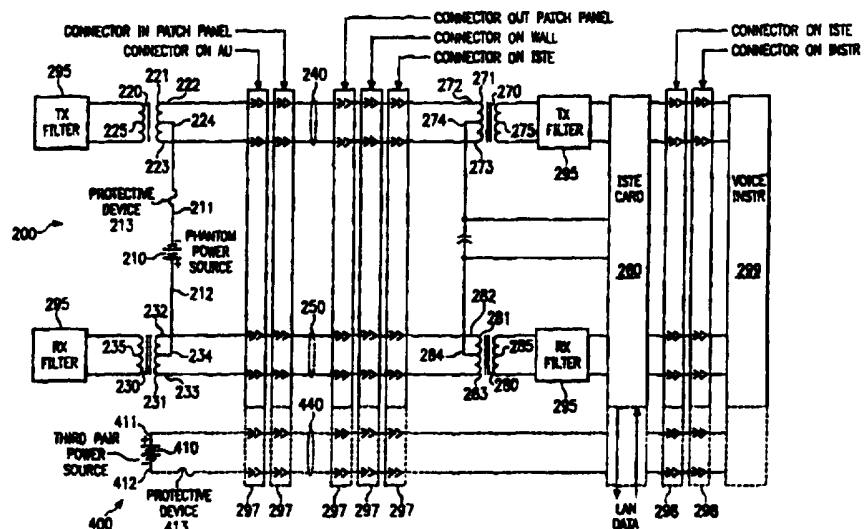

INTERNATIONAL APPLICATION PUBLISHED UNDER THE PATENT COOPERATION TREATY (PCT)

<p>(51) International Patent Classification ⁶ : H04L 12/10, H04Q 11/04, H04M 19/08</p>	<p>A1</p>	<p>(11) International Publication Number: WO 96/23377</p>
		<p>(43) International Publication Date: 1 August 1996 (01.08.96)</p>
<p>(21) International Application Number: PCT/IB96/00223</p>	<p>(81) Designated States: AL, AM, AT, AU, AZ, BB, BG, BR, BY, CA, CH, CN, CZ, DE, DK, EE, ES, FI, GB, GE, HU, IS, JP, KE, KG, KP, KR, KZ, LK, LR, LS, LT, LU, LV, MD, MG, MK, MN, MW, MX, NO, NZ, PL, PT, RO, RU, SD, SE, SG, SI, SK, TJ, TM, TR, TT, UA, UG, UZ, VN, ARIPO patent (KE, LS, MW, SD, SZ, UG), Eurasian patent (AZ, BY, KG, KZ, RU, TJ, TM), European patent (AT, BE, CH, DE, DK, ES, FR, GB, GR, IE, IT, LU, MC, NL, PT, SE), OAPI patent (BF, BJ, CF, CG, CI, CM, GA, GN, ML, MR, NE, SN, TD, TG).</p>	
<p>(22) International Filing Date: 26 January 1996 (26.01.96)</p>		
<p>(30) Priority Data: 08/379,365 27 January 1995 (27.01.95) US</p>		
<p>(71) Applicant: INTECOM, INCORPORATED [US/US]; 5057 Keller Springs Road, Dallas, TX 75248 (US).</p>		
<p>(72) Inventors: HUNTER, Richard, K.; Apartment 804, 4815 Westgrove Road, Dallas, TX 75248 (US). PLATT, Richard, B.; 1111 Ashby Drive, Allen, TX 75002 (US).</p>	<p>Published <i>With international search report. Before the expiration of the time limit for amending the claims and to be republished in the event of the receipt of amendments.</i></p>	
<p>(74) Agent: HITT, David, H.; Hitt Chwang & Gaines, P.C., Suite 225, 275 West Campbell Road, Richardson, TX 75080 (US).</p>		

(54) Title: MULTIMEDIA SYSTEM HAVING CENTRAL POWER SOURCE AND DISTRIBUTION SUBSYSTEM



(57) Abstract

A power subsystem and method for providing phantom power and third pair power via a computer network bus, the bus including first and second conductors. The phantom power subsystem comprises: (1) a power supply having a positive output and a negative output, the power supply adapted to provide power via the positive and negative outputs and (2) first and second transformers, each of the first and second transformers having a winding, each of the windings having a pair of end taps and a center tap, the first conductor coupled to the end taps of the winding of the first transformer to allow data communication therebetween, the second conductor coupled to the end taps of the winding of the second transformer to allow data communication therebetween, the positive and negative outputs of the power supply coupled to the center taps of the windings of the first and second transformers, respectively, to allow the power supply to transmit the power, via the first and second transformers and the first and second conductors, to equipment couplable to the first and second conductors.

FOR THE PURPOSES OF INFORMATION ONLY

Codes used to identify States party to the PCT on the front pages of pamphlets publishing international applications under the PCT.

AM	Armenia	GB	United Kingdom	MW	Malawi
AT	Austria	GE	Georgia	MX	Mexico
AU	Australia	GN	Guinea	NE	Niger
BB	Barbados	GR	Greece	NL	Netherlands
BE	Belgium	HU	Hungary	NO	Norway
BF	Burkina Faso	IE	Ireland	NZ	New Zealand
BG	Bulgaria	IT	Italy	PL	Poland
BJ	Benin	JP	Japan	PT	Portugal
BR	Brazil	KE	Kenya	RO	Romania
BY	Belarus	KG	Kyrgystan	RU	Russian Federation
CA	Canada	KP	Democratic People's Republic of Korea	SD	Sudan
CF	Central African Republic	KR	Republic of Korea	SE	Sweden
CG	Congo	KZ	Kazakhstan	SG	Singapore
CH	Switzerland	LI	Liechtenstein	SI	Slovenia
CI	Côte d'Ivoire	LK	Sri Lanka	SK	Slovakia
CM	Cameroon	LR	Liberia	SN	Senegal
CN	China	LT	Lithuania	SZ	Swaziland
CS	Czechoslovakia	LU	Luxembourg	TD	Chad
CZ	Czech Republic	LV	Latvia	TG	Togo
DE	Germany	MC	Monaco	TJ	Tajikistan
DK	Denmark	MD	Republic of Moldova	TT	Trinidad and Tobago
EE	Estonia	MG	Madagascar	UA	Ukraine
ES	Spain	ML	Mali	UG	Uganda
FI	Finland	MN	Mongolia	US	United States of America
FR	France	MR	Mauritania	UZ	Uzbekistan
GA	Gabon			VN	Viet Nam

**MULTIMEDIA SYSTEM HAVING CENTRAL POWER SOURCE
AND DISTRIBUTION SUBSYSTEM**

TECHNICAL FIELD OF THE INVENTION

The present invention is directed, in general, to
5 multimedia systems and, more specifically, to a power
subsystem for a multimedia subsystem and a method of
providing phantom and third pair power therefor, the
subsystem providing a central power source and distribution
of power to equipment comprising the system.

10

BACKGROUND OF THE INVENTION

Currently, "Information superhighway" and "multimedia"
are probably the most often spoken and least often
understood aspects of a coming revolution in data
communication. Although issues specific to an information
15 superhighway are beyond the scope of the present
discussion, interactive multimedia systems are very much
within the present scope.

An interactive multimedia system is broadly defined as
a system capable of processing, storing, communicating and
20 coordinating data pertaining to visual information, aural

information and other information. Visual information is generally divided into still picture or graphics and full motion video or animation categories. In the vernacular of those involved in multimedia, such visual information is generically referred to as "video." Aural information is generally divided into speech and non-speech categories and is generically referred to as "voice." "Other information" is directed primarily to computer data, often organized in files and records, and perhaps constituting textual and graphical data. Such computer data are generally referred to as "data."

To date, multimedia has, for the most part, been limited to stand-alone computer systems or computer systems linked together in a local area network ("LAN"). While such isolated systems have proven popular and entertaining, the true value of multimedia will become apparent only when multimedia-capable wide area networks ("WANs") and protocol systems are developed, standardized and installed that permit truly interactive multimedia. Such multimedia systems will allow long distance communication of useful quantities of coordinated voice, video and data, providing, in effect, a multimedia extension to the voice-only services of the ubiquitous telephone network.

Defining the structure and operation of an interactive multimedia system is a critical first step in the development of such system. Accordingly, before entering into a discussion herein of more specific design issues, it is important to discuss more general questions that need to be resolved concerning design objectives of the system as

a whole and some generally agreed-upon answers and specifications.

Interactive multimedia may be thought of as an electronic approximation of the paradigm of interactive group discussion. It involves the interactive exchange of voice, video and data between two or more people through an electronic medium in real time. Because of its interactive and real-time nature, there are some stringent requirements and required services not normally associated with multimedia retrieval systems. Some of the more obvious examples of those requirements and services include latency (transmission delay), conferencing, availability ("up-time") and WAN interoperability.

The evolution of existing private branch exchange ("PBX") and LAN topologies towards a composite interactive multimedia system based upon client/server architectures and isochronous networks is a natural trend. However, to merge the disparate mediums of voice, video and data successfully into a cohesive network requires that three fundamental integration issues be defined and resolved. The first of the fundamental integration issues is quality of service ("QoS"). QoS is defined as the effective communication bandwidth, services and media quality coupling of separate equipment or "terminals" together and the availability ("up-time") of the same. QoS parameters are divided into four groups: 1) terminal QoS, 2) network QoS, 3) system QoS, and 4) availability requirements. Thus, QoS parameters must be defined for both terminal equipment ("TE") and network equipment ("NE") governing the

communication of data between the TE. System QoS is derived from a combination of terminal and network QoS. The suggested values for QoS parameters are considered to be a practical compromise between required service quality, technology and cost. See, Multimedia Communications Forum ("MMCF") Working Document "Architecture and Network QoS", ARCH/QOS/94-001, Rev. 1.7, MMCF, (September 1994) and ITU-T Recommendation I.350 "General Aspects of Quality of Service and Network Performance in Digital Networks, including Integrated Services Digital Networks ("ISDNs"), (1993). The following Table I summarizes some suggested parameters for terminal QoS.

Parameter Type	Parameter Value	Parameter Explanation
Audio Frequency Range	3.4kHz	Optimization is for voice, and is consistent with existing Legacy voice systems.
Audio Level	-10dBmO	Optimization is for voice, and is consistent with Legacy voice systems.
5 Audio Encoding	G.711 (8-bit pulse code modulation ("PCM"))	Consistent with Legacy voice systems.
Video Resolution	≥ 352x288 (SIF)	Minimal acceptable size for video conferencing.
Video Frame Rate	≥ 20 frames per second (fps)	Minimal optimization for detection of facial expression transitions.
10 Voice/Video Intramedia-Intermedia Differential Delay	< 100 milliseconds (ms)	A differential delay greater than 100ms between voice & video is noticeably significant.
Video Encoding	H.261 & Motion Picture Experts Group ("MPEG")-1	H.261 meets WAN interoperability, MPEG-1 is more consistent with desktop trends and quality requirements.

Parameter Type	Parameter Value	Parameter Explanation
Intramedia Latency (TE)	< 100ms	The delay of the TE itself for encoding and framing purposes.
User Data Rate	≥ 64kbps	Minimal acceptable data bandwidth for data sharing applications. Consistent with ISDN Basic Rate Instrument ("BRI").
Data Encoding	HDLC encapsulation	Consistent with isochronous service bearer channels.

5

Table I - Terminal QoS Parameters

Network QoS parameter requirements consist of those parts of the system that are between two TE endpoints. This includes a portion of the TE itself, the private network (if required), and the public network (if required). Some of the requirements imposed upon the network QoS are a result of the terminal QoS parameters. The following Table II summarizes the network QoS requirements.

5

Parameter Type	Parameter Value	Parameter Explanation
Intramedia Latency (NE)	< 50ms	Intramedia latency is the delay between source TE transmission and destination TE reception; i.e. the delay of NE.
Network Capacity	≥ 1,536 kbps	G.711 Audio (64 kbps), MPEG-1 Video (1,344kbps), HDLC data (128kbps).

Table II - Network QoS Parameters

The system QoS encompasses the terminal and network elements. The particular value critical to the system is the intramedia latency. The following Table III summarizes this value that is the sum of the terminal and network values for the same parameter.

10

Parameter Type	Parameter Value	Parameter Explanation
Intramedia Latency (System)	< 150ms	Intramedia latency is the delay between source transmission and destination reception. It includes latency imposed by the source and destination TEs as well as the NE. These latency values might include encoding and decoding delays, transmission delays, and adaptation delays.

15

Table III - System QoS Parameters

The system QoS parameter of Intramedia Latency is the sum of the TE and NE latency. Intramedia Latency parameter value is bounded by voice requirements since latent delay is more readily perceived by the ear than the eye.
5 However, the delay itself is typically a function of video since it is the component requiring the most time for encoding and decoding.

Availability ("up-time") includes several aspects. In particular, the network elements have very strict
10 requirements. These requirements are typical of private branch exchanges ("PBXs") and other private network voice equipment, but are very atypical of Legacy LANs. Most LANs are susceptible to power-losses, single points of failure, and errant TE. An interactive multimedia system must
15 closely follow the availability requirements of the legacy voice systems. The following Table IV summarizes Availability QoS parameters.

Parameter Type	Parameter Value	Parameter Explanation
TE Power Requirements	5 watts (W) of phantom power (48 volts (V))	This power requirement is consistent with the ISDN BRI requirements and will allow the least common denominator of voice to function.
5 NE Power Requirements	Uninterruptable power supply ("UPS")	NE must be UPS capable including private NE.
Single point of failure	12 Users	No more than 12 users should be impacted by a single point of failure.
10 Error Free Seconds Ratio ("EFS")	> 99.9%	Meets requirement of random bit error rate of 10^{-6} .

Table IV - Availability QoS Parameters

The availability requirements are defined solely within the context of the private network. Additional availability parameters are discussed in G.821. See also, 15 MMCF Working Document "Architecture and Network QoS", ARCH/QOS/94-001, Rev. 1.7, Multimedia Communications Forum, Inc., (September 1994) and TR-TSY-000499, Transport Systems Generic Requirements (TSGR): Common Requirements, Bellcore Technical Reference, Issue 3, (December 1989).

20 The second of the fundamental integration issues is network services. Network services include transport

services, connection management and feature management. Multimedia communication involves the transmission of data having more varied characteristics than video, voice or data in isolation. Therefore, the manner in which the network transports and manages the flow of video, voice and data is critical to the efficiency, flexibility and overall effectiveness of the network.

Transport services can be categorized into three groups: 1) packet, 2) circuit and 3) cell. The following Table V summarizes different aspects of each of these transport services.

	Packet	Circuit	Cell
Typical technology	Ethernet®, Token Ring®, Frame Relay®, etc.	ISDN, T1	Asynchronous Transfer Mode ("ATM")
Media optimization	Packet data	Isochronous data (voice, video)	Packet & isochronous data
Transport optimization	Multicast, shared medium operations	Point-point, full-duplex, low-cost switching	Point-point, full-duplex, high-speed switching
Optimized data size	1500 bytes (Ethernet®)	1 byte (voice)	48 bytes
Transport Overhead	4.2% (64 bytes - IP)	none	11.3% (6 bytes - AAL1)
Transport Methodology	Shared	Switched	Switched

	Packet	Circuit	Cell
Route Methodology	Routing	Signalling (circuit switching)	Signalling (virtual circuit switching)
Typical Deployment	Widespread. Deployed as LAN	Widespread. Deployed as both public network and private NE	Very few installations. Typically deployed as private backbone network

5 Table V - Transport Services

Interactive multimedia requires the usage of an isochronous network because of the QoS requirements for voice and video. While it is possible to construct a packet network with sufficient bandwidth, buffering and intelligence to accommodate synchronous traffic it is considered to be prohibitively expensive and unnecessary. Nevertheless, both the LAN, PBX and WAN require interoperability.

At some point it is expected that the entire private network infrastructure will employ ATM. This will transpire upon the occurrence of several events. First, WANs must adapt to support ATM Points-of-Presence ("POPs"). Second, the telephone must disappear from the premise (replaced by an ATM audio device). Third, packet-based LAN TE must become ATM TE. Fourth, phantom power must be supported to the ATM TE (for availability purposes). Fifth, an 8kHz synchronous clock must be supported and

managed by all ATM equipment. Finally, the price of ATM TE and NE must approach that of Ethernet®, ISDN, and isoEthernet® equipment.

Regardless of the interim private network
5 infrastructure, ATM is the only backbone solution for the private network. It is the only scalable switching architecture that can transport packet and isochronous data. Furthermore, because it is deployed as a backbone, the aforementioned issues do not apply.

10 Connection management is the process employed by the private and public network routing functions. Because packet routing is a well established and defined process, it is not discussed further. Connection management within the confines of an isochronous network for interactive
15 multimedia is a newer technology (albeit with old roots) and deserves discussion.

Signalling for circuit and cell switching is best defined by the ISDN signalling standards (see, TR-NWT-000938, Network Transmission Interface and Performance
20 Specification Supporting Integrated Digital Services Network (ISDN), Bellcore Technical Reference, Issue 1, (August 1990)), isoEthernet® signalling (see, IEEE Proposed Standard 802.9a, "Isochronous services with Carrier Sense Multiple Access with Collision Detection (CSMA/CD) Media
25 Access Control (MAC) service", (December 1994)) and ATM signalling (see, ATM Forum, "ATM User-Network Interface Specification - Version 3.0", (September 1993) and ITU-T Recommendation Q.293x, "Generic Concepts for the Support of Multipoint and Multiconnection Calls"; (1993)).

Historically, isochronous networks carry the signalling channel as an isochronous channel. Nevertheless, the signalling function can be shown to be better suited to a packet channel. A hub/routing function is the ideal location to perform the bridging between an isochronous signalling channel and a packet signalling channel. The natural packet protocol choice for a signalling channel is an Internet Protocol ("IETF IP"). Available on most LAN networks, as well as global routing capability, IP greatly enhances the signalling requirement of interactive multimedia.

Feature management consists of those features provided by the private and public network for interactivity purposes. The PBX is followed as a model for interactive multimedia features. The following Table VI summarizes some of the more common features.

	System Services	User Services	Maintenance
	Account Codes	Buzz Station	Automatic Restart
	Authorization Codes	Callback	Connection Detail Recording
5	Automatic Number Identification	Call Forward	Default Installation
	Direct Inward Dialing ("DID")	Call Park	Class of Service
10	Direct Outward Dialing ("DOD")	Call Pickup	Hot Configuration
	Hunt Groups	Call Waiting	
	Multimedia on hold	Do Not Disturb/Override	
15	Network Numbering Plan	Hold/Consultation Hold	
	Number Dial Plan	Last Number Redial	
	Shared Resource Queuing	Multiple/Shared Call Appearances	
20	System Speed Dialing	Conference (multiparty)	
	Vacant Number Intercept	Transfer	

Table VI - Feature Management

The third of the fundamental integration issues is interoperability. An interactive multimedia system by nature implies interoperability, because a multimedia network as envisioned is too large and far-flung to employ the equipment of only a single supplier. Therefore, standards must be established that allow equipment from different suppliers to interact smoothly. To this end,

interoperability must extend to transport mechanisms, signalling and compression standards.

There are certain existing communication technologies that must be supported and others that are used. A truly interoperable interactive multimedia system should guarantee that the physical and logical interfaces of each component adheres to a standard. Prior to 1992, this would have been almost impossible. The present day affords the opportunity to evolve the proprietary telephony of the PBX and the proprietary video of the video conferencing systems into standards-based systems in the same manner that the data systems evolved from proprietary mainframes to the standards-based LAN systems of today. The following Table VII summarizes the required standards of interoperability.

Transport Standards	Signalling Standards	Compression Standards
isoEthernet® (IEEE 802.9a)	ISDN NI-2	G.711, G.722 (Audio)
ATM	QSIG	H.221 (Video)
ISDN	Q.2931	MPEG-1 (Video)
	H.320 (Audiovisual)	

Table VII - Interoperability Standards

In addition to the standards required for communications, there are other standards relating to application programming interfaces for terminal and server control. These include Microsoft® Telephony Application

Programming Interface ("TAPI®"), Novell TSAPI®, and Microsoft® ODBC®.

Having now set the stage with a discussion of general issues concerning multimedia systems, more specific design
5 issues may now be discussed. The specific design issue of concern is provision of power to guarantee TE availability.

IEEE draft standard 802.9a provides for the integration of video, voice and data services to a desktop computer system. A needed step in the evolution of this
10 integration is to provide for a level of service equal to or greater than that currently available from LAN, PBX and WAN systems.

In the case of voice services, i.e. telephony, users have come to expect service under all conditions. In the
15 PBX realm, this is commonly referred to as "dialtone is an inalienable right." Users expect basic voice service regardless of the state of the desktop computer system, building power, weather, time of day and other external factors.

This principal is in concert with the above-mentioned
20 requirement that power must be supported to the ATM TE for availability purposes to establish ATM as the foundation for the private network infrastructure. The TE thus must support at least voice in case of power or device failure
25 of the client.

Power for the TE can be supplied in one of three ways. First, a local (in the office) power supply can supply power to the TE, much in the same way an uninterruptable power supply functions to supply power to a personal

computer ("PC") in case of power failure. This is local powering. Second, power may be routed through the same cable employed to carry data through the network. This is phantom powering and is employed in current telephone systems. Third, power may be routed through a separate, dedicated power cable. Since LANs often operate with a two twisted-pair data bus, this method of delivering power is often called third pair powering.

Local powering, though possible, is relatively expensive, especially in the case of large multimedia installations, because a dedicated power supply providing power back-up must be purchased and coupled to the TE.

Phantom powering has the advantage of not requiring the installation of a dedicated power cable. However, since power is carried on the data bus a careful phantom power scheme must be implemented to avoid problems that may arise due to interactions between the power and the data, causing instability and imbalance on the bus and thereby reducing reliability.

Third pair powering has the advantage of separating the power from the data, thereby avoiding potentially harmful interactions. This also preserves existing standard bus interface circuitry. However, third pair powering requires a dedicated power cable, increasing the cost of new installations and existing installations where a dedicated power cable is not already in place.

It is desirable to provide options for both phantom and third pair powering in the environment of a local area network without significantly altering the topology of the

network. Accordingly, what is needed in the art are a power subsystem and method for a multimedia subsystem that provide a central power source and distribution of the power to equipment comprising the system within the context
5 of LAN or isochronous LAN transport mediums.

SUMMARY OF THE INVENTION

To address the above-discussed deficiencies of the prior art, it is a primary object of the present invention to provide power subsystems for providing either phantom or
5 third pair power to equipment coupled to a local area network, including, but not limited to, Ethernet®, Token Ring®, ATM and isoEthernet®. The subsystems allow equipment coupled to the network to be available even when the network is not operating due to an absence of local
10 power. It is a further primary object of the present invention to remain as compatible as possible with existing standards for video, voice and data communication.

In the attainment of the above primary objects, the present invention provides a power subsystem and method for
15 providing phantom power and third pair power via a computer network backbone, the bus including first and second conductors.

In a first aspect, the present invention provides a phantom power subsystem comprising: (1) a power supply
20 having a positive output and a negative output, the power supply adapted to provide power via the positive and negative outputs and (2) first and second transformers, each of the first and second transformers having a winding, each of the windings having a pair of end taps and a center
25 tap, the first conductor coupled to the end taps of the winding of the first transformer to allow data communication therebetween, the second conductor coupled to the end taps of the winding of the second transformer to

allow data communication therebetween, the positive and negative outputs of the power supply coupled to the center taps of the windings of the first and second transformers, respectively, to allow the power supply to transmit the
5 power, via the first and second transformers and the first and second conductors, to equipment couplable to the first and second conductors. In one embodiment, the first and second conductors are twisted-pair conductors, although untwisted-pair, coaxial and other conductors are within the
10 scope of the present invention.

Thus, the present invention, in this first aspect, provides a power supply, center-tap transformer combination allowing power to be introduced into the conductors and throughout the computer network. Thus, the concept of
15 phantom power has been extended significantly to operate with data-bearing LAN buses. At this point, it should be noted that "conductor" and "cable" may be used interchangeably.

It is also apparent that the above first aspect of the
20 present invention provides a phantom powering subsystem suitable for powering a multimedia system meeting the general design criteria set forth in the Background of the Invention.

In a preferred embodiment of the first aspect of the
25 present invention, the subsystem further comprises third and fourth transformers, each of the third and fourth transformers having a winding, each of the windings having a pair of end taps and a center tap, the first conductor coupled to the end taps of the winding of the third

transformer to allow data communication therebetween, the second conductor coupled to the end taps of the winding of the fourth transformer to allow data communication therebetween, the positive and negative inputs of equipment
5 coupled to the center taps of the windings of the third and fourth transformers, respectively, to allow the power supply to transmit the power, via the first and second transformers, the first and second conductors and the third and fourth transformers, to the equipment.

10 The third and fourth transformers allow the equipment to draw power from the conductors. In an overall LAN, many pieces of equipment, each with its own third and fourth transformers, can take power as well as data from the bus. Thus, telephone instruments coupled to the equipment can
15 remain powered even when associated devices are not or in the event of a power failure.

In a preferred embodiment of the first aspect of the present invention, the bus comprises a 10Base-T bus. Those of skill in the art will recognize, however, that the
20 present invention is also compatible with Ethernet®, Token Ring®, ATM and isoEthernet® standards.

A 10Base-T bus conventionally comprises two twisted-pair conductors, each used for unidirectional transmission of data. Thus, in this embodiment, one of the twisted
25 pairs is employed for transmitting data from equipment, while the other of the twisted-pairs is used for receiving data into the equipment. The present invention preferably employs each of the twisted-pair conductors as a rail by which to deliver DC power to the equipment.

The windings of the first and second transformers may have two center taps and may employ a balance circuit coupling the two center taps of each of the windings of the first and second transformers to the positive and negative
5 outputs, respectively. In a manner to be described more particularly, the balance circuit is designed to correct any current imbalances that may be present in the conductors due to varying impedances therein.

The subsystem may further comprise first and second
10 balance circuits coupling the positive and negative outputs to the center taps of the windings of the first and second transformers, respectively. Thus, two balance circuits may be employed to balance the two conductors against each other. Of course, those of skill in the art will recognize
15 that the balance circuits may be deleted at the risk of impairing signal quality.

In a preferred embodiment of the first aspect of the present invention, each of the first and second transformers has a second winding, the second windings
20 coupled to respective filter circuits.

The first and second transformers therefore act as isolation transformers, isolating the DC bias of the power subsystem from data inputs on the equipment. Accordingly, the second windings are coupled to filters to provide
25 further conditioning of the data signals before they are introduced into the equipment.

In a preferred embodiment of the first aspect of the present invention, the subsystem further comprises a protective device coupled to the power supply to prevent

power exceeding a desired amount from passing through the protective device.

The protective device is more preferably a resettable device, such as a thermistor or polyfuse, designed mutually
5 to protect the power supply and the bus from overcurrents that may damage either. Of course, such protective device is desirable, but not necessary to the present invention.

In a preferred embodiment of the first aspect of the present invention, the power is supplied at about 48V. As
10 previously mentioned, this power requirement is consistent with the ISDN BRI requirements and will allow the least common denominator of voice to function.

In a preferred embodiment of the first aspect of the present invention, the first and second transformers have
15 a mutual inductance of about 350 microhenrys (μHy). Transformers of such size are a standard size for a 10Base-T LAN system.

In a preferred embodiment of the first aspect of the present invention, the equipment is an Integrated Services
20 Terminal Equipment ("ISTE") device. Such equipment is compatible with ISDN standards. This is in accord with an object of the present invention concerning the compatibility of the present invention with existing standards.

25 In a second aspect, the present invention provides a bus interface for a LAN, comprising: an isolation transformer having a primary winding and a secondary winding, the primary winding having first and second end taps and first and second center taps, the secondary

winding having first and second end taps, the first and second end taps of the primary winding adapted to be coupled to a bus of the LAN, the first and second end taps of the secondary winding adapted to be coupled to a data
5 input of equipment, the first and second center taps of the primary winding cooperating to provide a power output adapted to be coupled to a power input of the equipment to provide a voltage reference therefor, the isolation transformer substantially preventing the voltage reference
10 from DC-biasing the secondary winding, the power output forming a portion of a power supply for the equipment.

This aspect of the present invention is directed to an interface, preferably modular, that allows the LAN bus to be coupled to equipment. The equipment can thereby derive
15 video, voice, data and power from the LAN bus with the interface as described.

In a preferred embodiment of the second aspect of the present invention, the interface further comprises: a second isolation transformer having a primary winding and
20 a secondary winding, the primary winding of the second isolation transformer having first and second end taps and first and second center taps, the secondary winding of the second isolation transformer having first and second end taps, the first and second end taps of the primary winding
25 of the second isolation transformer adapted to be coupled to the bus of the LAN, the first and second end taps of the secondary winding of the second isolation transformer adapted to be coupled to the data input of the equipment, the first and second center taps of the primary winding of

the second isolation transformer cooperating to provide a second power output adapted to be coupled to the power input of the equipment to provide a second voltage reference therefor, the second isolation transformer substantially preventing the voltage reference from DC-biasing the secondary winding of the second isolation transformer, the voltage reference and the second voltage reference cooperating to form the power supply for the equipment.

10 In this preferred embodiment, the interface bridges the bus with two isolation transformers, producing the rails of a DC power supply from each of the isolation transformers. Preferably, great care is taken to maintain isolation between the separate conductors of the bus to maintain data integrity and to maintain isolation between the bus and the data input on the equipment, thereby preventing power from entering the data input and compromising operation of the equipment.

Balance circuitry comprising a first resistor coupling the first center tap to the power output and a second resistor coupling the second center tap to the power output may aid in increasing signal quality. The resistors reduce imbalances in the bus due to varying connector and bus conductor impedances.

25 The balance circuitry may also comprise a capacitor coupling the first and second center taps. The capacitor reduces data loss that may be experienced through the first and second resistors of the embodiment immediately above. The isolation transformer may also comprise separate cores,

the first and second center taps spanning the separate cores.

In a preferred embodiment of the second aspect of the present invention, the bus comprises two twisted-pair
5 conductors. One standard that employs this arrangement of twisted-pair conductors is 10Base-T, as described above. Thus, in a preferred embodiment of the second aspect of the present invention, the bus comprises a 10Base-T bus. Those
of skill in the art will recognize, however, that the
10 present invention is also compatible with Ethernet[®], Token Ring[®], ATM and isoEthernet[®] standards.

In a preferred embodiment of the second aspect of the present invention, the first and second end taps of the secondary winding are adapted to be coupled to the data
15 input of the equipment via a filter circuit. Again, a filter circuit is employed on the equipment end of the interface to provide signal conditioning for the data prior to entering the data input of the equipment.

As with the first aspect, in a preferred embodiment of
20 the second aspect of the present invention, the equipment is an ISTE device.

In a preferred embodiment of the second aspect of the present invention, the interface further comprises a shunt capacitor coupling the power output and the second power
25 output. The shunt capacitor provides smoothing of the DC power derived from the center taps of the respective isolation transformers. Thus, any stray AC frequencies (perhaps gleaned from the data on the bus) may be filtered away.

In a third aspect, the present invention provides a third pair power subsystem comprising: (1) a power supply having a positive output and a negative output, the power supply adapted to provide power via the positive and negative outputs and (2) third pair conductors coupled to the positive and negative outputs, respectively, the third pair conductors adapted to deliver the power to the equipment coupled to the first and second conductors and the third pair conductors.

10 In this aspect of the present invention, third pair, rather than phantom powering, is the objective. As described previously, there may be applications in which third pair powering is advantageous. Accordingly, the present invention introduces a third pair of conductors to existing two-twisted-pair network buses. The third pair, which need not be twisted, acts as the power bus, couplable to equipment that also spans the first and second conductors.

20 It is also apparent that the above third aspect of the present invention provides a third pair powering subsystem suitable for powering a multimedia system meeting the general design criteria set forth in the Background of the Invention.

25 In a preferred embodiment of the third aspect of the present invention, the equipment is coupled to a voice instrument, the power supply thereby providing power to the voice instrument. As described previously, the present invention is, in some embodiments, directed toward providing only the necessary power to enable operation of

voice instruments. Accordingly, the third pair embodiment of the present invention is preferably coupled to a voice instrument.

In a preferred embodiment of the third aspect of the present invention, the bus comprises a 10Base-T bus. As described, a 10Base-T bus provides two twisted-pair conductors.

In a preferred embodiment of the third aspect of the present invention, the power is between about 1W and about 8W. Although it is anticipated that TE adhering to ISDN standards only requires about 3W-5W to operate, the present invention is capable of providing up to 8W in this preferred embodiment.

In a preferred embodiment of the third aspect of the present invention, the power supply is powered by a DC source. Those of skill in the art will recognize, however, that the power supply may be powered by an AC source, as converted by a rectifier circuit, or by some other means.

In a preferred embodiment of the third aspect of the present invention, the first and second conductors communicate data over a computer network.

In a preferred embodiment of the third aspect of the present invention, the subsystem further comprises a protective device coupled to the power supply to prevent power exceeding a desired amount from passing through the protective device. In the third pair powering aspect, data and power do not mix. However, the present invention still preferably includes a protective device, such as a thermistor or polyfuse mutually to protect the power supply

and the third pair conductor from overcurrents that may damage either. Again, such protective device is desirable, but not necessary to the present invention.

In a preferred embodiment of the third aspect of the present invention, the power is supplied at about 48V. Again, this power requirement is consistent with the ISDN BRI requirements and will allow the least common denominator of voice to function.

In a preferred embodiment of the third aspect of the present invention, the third pair conductors are twisted. Thus, the present invention is useful in an environment where three twisted pairs of cables may already be installed in place. Those of skill in the art will recognize, however, that the shielding afforded by twisted-pair wire is not critical to transmission of DC power.

Finally, in a preferred embodiment of the third aspect of the present invention, the equipment is an ISTE device. Thus, the third pair aspect is fully compatible with ISDN.

The foregoing has outlined rather broadly the features and technical advantages of the present invention so that those skilled in the art may better understand the detailed description of the invention that follows. Additional features and advantages of the invention will be described hereinafter that form the subject of the claims of the invention. Those skilled in the art should appreciate that they can readily use the disclosed conception and specific embodiment as a basis for designing or modifying other structures for carrying out the same purposes of the present invention. Those skilled in the art should also

realize that such equivalent constructions do not depart from the spirit and scope of the invention in its broadest form.

BRIEF DESCRIPTION OF THE DRAWINGS

For a more complete understanding of the present invention, and the advantages thereof, reference is now made to the following descriptions taken in conjunction
5 with the accompanying drawings, in which:

FIGURE 1 illustrates a system diagram of an interactive multimedia system employing the power subsystem of the present invention;

FIGURE 2 illustrates a schematic diagram of a phantom
10 powering subsystem according to the first aspect of the present invention and an alternative third pair powering subsystem according to the third aspect of the present invention; and

FIGURE 3 illustrates a schematic diagram of a portion
15 of the phantom powering subsystem of FIGURE 2, showing, in particular, a balance circuit.

DETAILED DESCRIPTION

Referring initially to FIGURE 1, illustrated is a system diagram of an interactive multimedia system employing the power subsystem of the present invention.

5 The system, generally designated 100, may comprise a multimedia chassis 110 adapted to receive a plurality of cards therein. The system 100 may alternatively or additionally comprise a plurality of hubs in separate chassis. In the latter case, each of the hubs would
10 contain one of the cards otherwise located in the multimedia chassis 110. Because the hubs are separate from each other, the following discussion will be directed to hubs as opposed to cards in the multimedia chassis 110, although it should be understood that the hubs can as
15 easily exist as cards within the multimedia chassis 110.

A multimedia hub 120 forms a principal component of the system 100. In the illustrated embodiment, the multimedia hub 120 contains the following functions: 10Base-T hub repeater, B-channel switch, isoEthernet®
20 interfaces (allowing a multimedia PC 125, including an associated video camera 126 and telephone instrument 127, to be coupled thereto), encapsulated D channel over IP bridge, encapsulated IP over D-channel bridge, tone plant, digital signal processing ("DSP") functions (such as a
25 conference bridge, tone detection, call progress detection, multimedia record/playback and a music interface) and a System Network Management Protocol ("SNMP") agent. Thus, it is readily apparent that most of the system 100

functions involving translation or bridging among standards is handled in the multimedia hub 120.

An ATM hub 137 provides bridging between the multimedia chassis 110 and/or one or more multimedia hubs 5 120. This allows the system 100 to interface with an ATM backbone. The ATM hub 137 preferably contains 16 155 Mbps OC-3c ATM interfaces. Thus, the ATM hub 137 can be connected to as many as 16 multimedia hubs 120 or non-multimedia PCS 135. The ATM hub 137 may interface to an 10 ATM backbone (not shown) via a higher rate OC-x ATM hub 137.

An ISDN Primary Rate Instrument ("PRI") hub 140 provides a bridge to a WAN 145 through multiple ISDN T1 or E1 Primary Rate interfaces. The ISDN PRI hub 140 contains 15 two isoEthernet® interfaces. This provides redundant connections between the ISDN PRI hub 140 and the multimedia hub 120.

An ISDN BRI hub 150 provides a bridge for ISDN BRI telephone instruments and interfaces 155. A workstation 20 (not shown) may therefore control its telephone via Ethernet®. The ISDN BRI hub 150 is capable of associating the workstation with its corresponding telephone since the ISDN BRI hub 150 has access to both Ethernet® and D-channel signalling. The ISDN BRI hub 150 appears as the network 25 end to the ISDN BRI instruments and interfaces 155 and supports NI-2 compatible BRI instruments only.

The ISDN BRI hub 150 contains between 12 and 24 BRI interfaces. As with the ISDN PRI hub 140, the ISDN BRI hub 150 contains two isoEthernet® interfaces. This provides

redundant connections between the ISDN BRI hub 150 and the multimedia hub 120.

An analog telephony hub 160 provides connectivity for Plain Old Telephone Sets ("POTS") 165. The analog
5 telephony hub contains coder/decoders ("CODECs") and DSP functionality. Consequently, the POTS 165 appear to the system 100 as BRI sets. Furthermore, a workstation (not shown) may control its POTS 165 via Ethernet®. The analog telephony hub 160 is capable of associating the workstation
10 with its corresponding telephone since the analog telephony hub 160 has access to both Ethernet® and D-channel signalling. The analog telephony hub 160 contains 12-24 analog ports. Again, as with the ISDN PRI hub 140 and the ISDN BRI hub 150, the analog telephony hub 160 contains two
15 isoEthernet® interfaces. This provides redundant connections between the analog telephony hub 160 and the multimedia hub 120.

A 10Base-T hub 170 provides 24 SNMP-managed 10 Base-T ports. The 10Base-T hub 170 further provides an Ethernet®
20 AU interface and a single 10Base-F network interface.

An isoBridge hub 180 provides a bridging function between an isochronous network and a packet network. The isoBridge hub 180 is typically used in work-at-home applications wherein an end station is communicating via a
25 fax/modem through an isochronous WAN into a packet-based Ethernet®. The isoBridge hub 180 performs the conversion of fax/modem data and/or HDLC data to and from Ethernet® packets. The isoBridge hub 180 contains no station

interface but does contain two isoEthernet® network interfaces.

A server 190 is coupled to the multimedia hub 120. The server performs a variety of connection management, feature management and system management functions. The
5 server is preferably comprised of server software executing on widely-available server platforms, such as Intel, MIPS and Digital Equipment Corporation (DEC) Alpha servers. The operating system of choice is Microsoft® Windows® NT
10 Server, adapted to execute on the above-listed servers.

Given this flexible platform, the server 190 is capable of the following features: preemptive multitasking, symmetric multi-processing ("SMP"), security, executing virtual device drivers, multiple packet network stacks
15 (such as TCP/IP and IPX), reliability (redundant array of inexpensive disks ("RAID"), for instance), multiple languages and SNMP management. The server 190 further contains a management function, effected in the illustrated embodiment by Hewlett-Packard's OpenView® and an object-
20 oriented database.

Turning now to FIGURE 2, illustrated is a schematic diagram of a phantom powering subsystem, generally designated 200, according to the first aspect of the present invention and an alternative third pair powering
25 subsystem, generally designated 400, according to the third aspect of the present invention.

The phantom powering subsystem 200 comprises a power supply 210 having a positive output 211 and a negative output 212. The power supply 210 is adapted to provide

power via the positive and negative outputs 211, 212. The subsystem 200 further comprises first and second transformers 220, 230. Each of the first and second transformers 220, 230 has a winding 221, 231 (respectively). Each of the windings has a pair of end taps 222, 223, 232, 233 and a center tap 224, 234. A first twisted-pair conductor 240 is coupled to the end taps 222, 223 of the winding 221 of the first transformer 220 to allow data communication therebetween. A second twisted-pair conductor 250 is coupled to the end taps 232, 233 of the winding 231 of the second transformer 230 to allow data communication therebetween. The positive and negative outputs 211, 212 of the power supply 210 are coupled to the center taps 224, 234 of the windings 221, 231 of the first and second transformers 220, 230, respectively, to allow the power supply 210 to transmit the power, via the first and second transformers 220, 230 and the first and second twisted-pair conductors 240, 250, to equipment 260 couplable to the first and second twisted-pair conductors 240, 250.

The subsystem 200 further comprises third and fourth transformers 270, 280. Each of the third and fourth transformers 270, 280 has a winding 271, 281 (respectively). Each of the windings has a pair of end taps 272, 273, 282, 283 and a center tap 274, 284. The first twisted-pair conductor 240 is coupled to the end taps 272, 273 of the winding 271 of the third transformer 270 to allow data communication therebetween. The second twisted-pair conductor 250 is coupled to the end taps 282, 283 of

the winding 281 of the fourth transformer 280 to allow data communication therebetween. Positive and negative inputs 261, 262 of the equipment 260 are coupled to the center taps 274, 284 of the windings 270, 280 of the third and
5 fourth transformers 270, 280, respectively, to allow the power supply 210 to transmit the power, via the first and second transformers 220, 230, the first and second twisted-pair conductors 240, 250 and the third and fourth transformers 270, 280, to the equipment 260.

10 The third and fourth transformers 270, 280 allow the equipment 260 to draw power from the twisted-pair conductors 240, 250, thereby enabling phantom powering. In an overall LAN, many pieces of equipment, each with its own third and fourth transformers 270, 280, can take power as
15 well as data from the bus. Thus, telephone instruments coupled to the equipment can remain powered even when associated devices are not or in the event of a power failure.

In the illustrated embodiment, the bus comprises a
20 10Base-T bus. A 10Base-T bus conventionally comprises two twisted-pair conductors 240, 250, each used for unidirectional transmission of data. Thus, in this embodiment, one of the twisted pairs (say, 250) is employed for transmitting data from the equipment 260, while the
25 other of the twisted-pairs (say, 240) is used for receiving data into the equipment 260. The present invention preferably employs each of the twisted-pair conductors as a rail by which to deliver DC power to the equipment 260.

In the illustrated embodiment, each of the first, second, third and fourth transformers 220, 230, 270, 280 has a second winding 225, 235, 275, 285. The second windings 225, 235, 275, 285 are coupled to respective
5 filter circuits 295. The first, second, third and fourth transformers 220, 230, 270, 280 therefore act as isolation transformers, isolating the DC bias of the power subsystem from data inputs on the equipment 260. Accordingly, the second windings 225, 235 are coupled to filters to provide
10 further conditioning of the data signals before they are introduced into the equipment 260.

The subsystem further comprises a protective device 213 coupled to the power supply 210 to prevent power exceeding a desired amount from passing through the
15 protective device 213. The protective device 213 is more preferably a thermistor or polyfuse, designed mutually to protect the power supply 210 and the bus (comprising the conductors 240, 250) from overcurrents that may damage either. Of course, such protective device 213 is
20 desirable, but not necessary to the present invention.

Various connectors are interposed to allow the twisted-pair conductors 240, 250 to be rerouted as necessary. These connectors include AU, patch panel, wall and NE-side ISTE connectors 297 and instrument-side ISTE
25 and instrument connectors 298. A voice instrument 299 is therefore couplable to the equipment 260 and receives both data and power therefrom.

In the illustrated embodiment, the power is supplied at about 48V. As previously mentioned, this power

requirement is consistent with the ISDN BRI requirements and will allow the least common denominator of voice to function. Power supplies with either AC or DC power backup mechanisms and a wide range of power levels are available
5 from multiple commercial sources. In addition DC-DC convertors to convert 48V to transistor-to-transistor logic ("TTL") voltage levels (i.e. 3V or 5V) are also readily commercially available. Use of 48V is below Underwriter's Laboratories-regulated levels and also reduces the current
10 levels to minimize voltage drop on connectors and cabling and impact to the transformers 220, 230. In the illustrated embodiment, the first and second transformers 220, 230 have a mutual inductance of about 350 μ Hy.

In the illustrated embodiment, the equipment 260 is an
15 ISTE device. Such equipment is compatible with ISDN standards. As previously stated, this is in accord with an object of the present invention concerning the compatibility of the present invention with existing standards.

20 Turning now to FIGURE 3 and with continuing reference to FIGURE 2, illustrated is a schematic diagram of a portion of the phantom powering subsystem of FIGURE 2, showing, in particular, a balance circuit 290. In the illustrated embodiment, the windings 221, 231, 271, 281 of
25 the first, second, third and fourth transformers 220, 230, 270, 280 have center taps 224, 234, 274, 284. A balance circuit 290 couples the respective center taps 224, 234, 274, 284 to the positive and negative outputs 211, 212 of the power supply 210 and positive and negative inputs on

the equipment 260, respectively. Thus, four balance circuits 290 are employed to balance the two twisted-pair conductors 240, 250 against each other. FIGURE 3 details one such balance circuit 290. Of course, those of skill in the art will recognize that the balance circuits 290 of the present invention may be deleted at the risk of impairing signal quality.

Preferably, data transmissions over the twisted-pair conductors are encoded to eliminate DC bias or offset, at least in theory. Such data may be Manchester-coded or, in a system employing isoEthernet®, coded 4B-5B with NRZI. In practice, however, some bias is inevitable when certain data patterns are transmitted; in fact, DC offset can be on the order of 6mA. The resistance imbalance in the twisted-pair conductors is 5% at the most. Using a transformer that can tolerate an 8mA offset, the maximum current that can be transmitted through the twisted-pair conductors is 320mA.

Table VIII, below, details the effects of connector imbalance. Such imbalance can be eliminated by adding 1% resistors 320, 330 in each leg.

	Output current	I_{out}	0.32A
	Cable resistance (5 meters 22 AWG)	R_c	0.481Ω
	Balancing Resistor	R_b	4Ω
	Resistance of connector(s) (5 @ .02Ω)	R_{conn}	0.1Ω
5	For Balance: $(I_{out}/2+.004) (R_c/1.05+R_b/1.01)$		
	$= (I_{out}/2-.004) (R_c*1.05+R_b*1.01+R_{conn})$		
	$(I_{out}/2+.004) (R_c/1.05+R_b/1.01) =$	0.725	
	$(I_{out}/2-.004) (R_c*1.05+R_b*1.01+R_{conn}) =$	0.725	

Table VIII - Connector Effects

10 The values of the balancing resistors 310, 320 are dependant on the current the load (the equipment 260 of FIGURE 2, for example) requires. Assuming 320mA load current and the worst case imbalance described below, the balancing resistors 310, 320 are preferably 4Ω per line.

15 This can be accomplished with 2Ω, 1% resistors at each end of the cable. Using eight such resistors 310, 320 allows the resistors to be built into a modular bus interface, described above as the second aspect of the present invention. The "worst case" resistors are based on: (1) 0Ω

20 in one path and 0.1Ω in the other path (.02Ω/connector * 5 connectors), (2) a five meter length of cable, with a 5% variation in the cables (a longer cable reduces imbalance) and (3) balancing resistors of 1% tolerance and at the extremes. Note that the two connectors 298 shown in FIGURE

25 2 between the equipment 260 (an ISTE device) and the voice

instrument 299 do not enter into the effects of connector imbalance.

The impact on power loss and voltage drop under normal operating conditions is minimal. The voltage drop at 320mA and 4Ω per leg is 1.28V. Loss of signal is eliminated by paralleling the resistors 310, 320 with a capacitor 330.

Table IX, below, lists the minimum and maximum resistances for 100 meters of copper wire. Note that, in calculating the resistance in the cable between the AU and ISTE in the case of phantom powering, the 2 wires of each twisted-pair conductor 240, 250 (transmit pair or receive pair) are in parallel and the 2 wires of each twisted-pair conductor 240, 250 (transmit pair and receive pair) are effectively in series.

AWG	Min @ 0°C	Max @ 0°C	Nominal	Min @ 50°C	Max @ 50°C
26	12.18	12.79	13.47	14.70	15.43
24	7.65	8.03	8.42	9.14	9.60
22	4.81	5.05	5.31	5.79	6.08

Table IX - Resistance of 100 Meters

Under conditions wherein a high current power supply is used for supplying multiple ISTE's, current limiting on each port should be used to protect against shorting. Thermistors and polyfuses are examples of inexpensive current-limiting devices that recover when the short is removed. The balancing resistors 310, 320 dissipate worst case power during overcurrent (short) fault conditions. Selection of the wattage rating of the balancing resistors

310, 320 should be coordinated with the current-limiting value of the protective device 213. For example, if the maximum short circuit is 500mA, then a ½W resistor is required ($P=I^2R=.5^2*2=.5W$).

5 Table X, below, lists (for the phantom powering case) the calculated voltage drop (resistance (wire + balance resistors + protective device + connectors) * current), power available to the load (ISTE) assuming low source voltage and power available to the load assuming nominal
 10 source voltage for 3 sizes of wire. The minimum power available to the ISTE is 8.89W. The conditions are: (1) 100 meters of 26 AWG cable and a cable temperature of 50°C, (2) voltage at the AU is 42V (allows for battery operation, batteries partially discharged), (3) the load current
 15 required by the ISTE is 320mA and (4) a current limiting device with a worst case resistance of 25Ω.

I	Worst Case Voltage Drop			Watts to Load - 42V at Hub			Watts to Load - 48V at Hub		
	26 AWG	24 AWG	22 AWG	26 AWG	24 AWG	22 AWG	26 AWG	24 AWG	22 AWG
.01	0.45	0.39	0.35	0.42	0.42	0.42	0.48	0.48	0.48
.02	0.89	0.77	0.70	0.82	0.82	0.83	0.94	0.94	0.95
20 .03	1.33	1.16	1.05	1.22	1.23	1.23	1.40	1.41	1.41
.04	1.78	1.54	1.40	1.61	1.62	1.62	1.85	1.86	1.86
.05	2.22	1.93	1.75	1.99	2.00	2.01	2.29	2.30	2.31
.06	2.67	2.32	2.10	2.36	2.38	2.39	2.72	2.74	2.75
.07	3.11	2.70	2.46	2.72	2.75	2.77	3.14	3.17	3.19
25 .08	3.55	3.09	2.81	3.08	3.11	3.14	3.56	3.59	3.62
.09	4.00	3.47	3.16	3.42	3.47	3.50	3.96	4.01	4.04
.10	4.44	3.86	3.51	3.76	3.81	3.85	4.36	4.41	4.45
.11	4.89	4.25	3.86	4.08	4.15	4.20	4.74	4.81	4.86

	Worst Case Voltage Drop			Watts to Load - 42V at Hub			Watts to Load - 48V at Hub			
	.12	5.33	4.63	4.21	4.40	4.48	4.53	5.12	5.20	5.25
	.13	5.78	5.02	4.56	4.71	4.81	4.87	5.49	5.59	5.65
	.14	6.22	5.40	4.91	5.01	5.12	5.19	5.85	5.98	6.03
	.15	6.67	5.79	5.26	5.30	5.43	5.51	6.20	6.33	6.41
5	.16	7.11	6.18	5.61	5.58	5.73	5.82	6.54	6.69	6.78
	.17	7.55	6.56	5.96	5.86	6.02	6.13	6.88	7.04	7.15
	.18	8.00	6.95	6.31	6.12	6.31	6.42	7.20	7.39	7.50
	.19	8.44	7.33	6.67	6.38	6.59	6.71	7.52	7.73	7.85
	.20	8.89	7.72	7.02	6.62	6.86	7.00	7.82	8.06	8.20
10	.21	9.33	8.11	7.37	6.86	7.12	7.27	8.12	8.38	8.53
	.22	9.78	8.49	7.72	7.09	7.37	7.54	8.41	8.69	8.86
	.23	10.22	8.88	8.07	7.31	7.62	7.80	8.69	9.00	9.18
	.24	10.66	9.26	8.42	7.52	7.86	8.06	8.96	9.30	9.50
	.25	11.11	9.65	8.77	7.72	8.09	8.31	9.22	9.59	9.81
15	.26	11.55	10.04	9.12	7.92	8.31	8.55	9.48	9.87	10.11
	.27	12.00	10.42	9.47	8.10	8.53	8.78	9.72	10.15	10.40
	.28	12.44	10.81	9.82	8.28	8.73	9.01	9.96	10.41	10.69
	.29	12.89	11.19	10.17	8.44	8.93	9.23	10.18	10.67	10.97
	.30	13.33	11.58	10.52	8.60	9.13	9.44	10.40	10.93	11.24
20	.31	13.77	11.97	10.88	8.75	9.31	9.65	10.61	11.17	11.51
	.32	14.22	12.35	11.23	8.89	9.49	9.85	10.81	11.41	11.77

Table X - Phantom Power Distribution from AU to ISTE

Table X also assumes that $R_b = 4\Omega$, $R_p = 25\Omega$ and $R_c = 0.2\Omega$.

25 Turning now back to FIGURE 2, the structure and operation of the third pair powering subsystem 400 of the third aspect of the present invention will now be described.

The third pair powering subsystem 400 is much simpler than the phantom power subsystem 200 first described. This is due entirely to the fact that power does not have to be first combined with, and then separated from, data signals.

5 Accordingly, the third pair power subsystem 400 comprises a power supply 410 (that may be of the same type as the power supply 210) has a positive output 411 and a negative output 412. The power supply 410 is adapted to provide power via the positive and negative outputs 411, 412. The

10 third pair powering subsystem 400 further comprises third pair conductors 440 coupled to the positive and negative outputs 411, 412, respectively. The third pair conductors 440 are adapted to deliver the power to the equipment 260 and the voice instrument 299 spanning to the first and

15 second twisted-pair conductors 240, 250 and the third pair conductors 440.

The present invention therefore introduces a third pair of conductors 440 to existing two-twisted-pair network buses. The third pair, which need not be twisted, acts as

20 the power bus, couplable to equipment that also spans the first and second twisted-pair conductors 240, 250.

As with the phantom powering subsystem 200, the third pair subsystem 400 further comprises a protective device 413 coupled to the power supply 410 to prevent power

25 exceeding a desired amount from passing through the protective device 413. The protective device 413 is more preferably a resettable device, such as a thermistor or polyfuse, designed mutually to protect the power supply 410 and the power bus (comprising the conductors 440) from

overcurrents that may damage either. Of course, such protective device 413 is desirable, but not necessary to the present invention.

Table XI enumerates, for the third pair powering case, the calculated voltage drop (Resistance (2*wire+protective device+connectors) * current), power available to the load (ISTE) assuming low source voltage, and power available to the load assuming nominal source voltage for 3 sizes of wire. The minimum power available to the ISTE is 7.70W. The conditions are: (1) 100 meters of 26 AWG cable and a cable temperature of 50°C, (2) voltage at the AU is 42 volts (allows for battery operation, batteries partially discharged), (3) the load current required by the ISTE is 320mA and (4) a current limiting device with a worst case resistance of 25Ω.

I	Worst Case Voltage Drop			Watts to Load - 42V at Hub			Watts to Load - 48V at Hub		
	26AWG	24AWG	22AWG	26AWG	24AWG	22AWG	26AWG	24AWG	22AWG
.01	0.56	0.44	0.37	0.41	0.42	0.42	0.47	0.48	0.48
.02	1.12	0.89	0.74	0.82	0.82	0.83	0.94	0.94	0.95
.03	1.68	1.33	1.11	1.21	1.22	1.23	1.39	1.40	1.41
.04	2.24	1.78	1.49	1.59	1.61	1.62	1.83	1.85	1.86
.05	2.80	2.22	1.86	1.96	1.99	2.01	2.26	2.29	2.31
.06	3.36	2.66	2.23	2.32	2.36	2.39	2.68	2.72	2.75
.07	3.92	3.11	2.60	2.67	2.72	2.76	3.09	3.14	3.18
.08	4.49	3.55	2.97	3.00	3.08	3.12	3.48	3.56	3.60
.09	5.05	4.00	3.34	3.33	3.42	3.48	3.87	3.96	4.02
.10	5.61	4.44	3.72	3.64	3.76	3.83	4.24	4.36	4.43
.11	6.17	4.88	4.09	3.94	4.08	4.17	4.60	4.74	4.83
.12	6.73	5.33	4.46	4.23	4.40	4.50	4.95	5.12	5.22
.13	7.29	5.77	4.83	4.51	4.71	4.83	5.29	5.49	5.61

	Worst Case Voltage Drop			Watts to Load - 42V at Hub			Watts to Load - 48V at Hub			
	.14	7.85	6.22	5.20	4.78	5.01	5.15	5.62	5.85	5.99
	.15	8.41	6.66	5.57	5.04	5.30	5.46	5.94	6.20	6.36
	.16	8.97	7.10	5.95	5.28	5.58	5.77	6.24	6.54	6.73
	.17	9.53	7.55	6.32	5.52	5.86	6.07	6.54	6.88	7.09
5	.18	10.09	7.99	6.69	5.74	6.12	6.36	6.82	7.20	7.44
	.19	10.65	8.44	7.06	5.96	6.38	6.64	7.10	7.52	7.78
	.20	11.21	8.88	7.43	6.16	6.62	6.91	7.36	7.82	8.11
	.21	11.77	9.32	7.80	6.35	6.86	7.18	7.61	8.12	8.44
	.22	12.33	9.77	8.18	6.53	7.09	7.44	7.85	8.41	8.76
10	.23	12.90	10.21	8.55	6.69	7.31	7.69	8.07	8.69	9.07
	.24	13.46	10.66	8.92	6.85	7.52	7.94	8.29	8.96	9.38
	.25	14.02	11.10	9.29	7.00	7.73	8.18	8.50	9.23	9.68
	.26	14.58	11.54	9.66	7.13	7.92	8.41	8.69	9.48	9.97
	.27	15.14	11.99	10.03	7.25	8.10	8.63	8.87	9.72	10.25
15	.28	15.70	12.43	10.41	7.36	8.28	8.85	9.04	9.96	10.53
	.29	16.26	12.87	10.78	7.46	8.45	9.05	9.20	10.19	10.79
	.30	16.82	13.32	11.15	7.55	8.60	9.26	9.35	10.40	11.06
	.31	17.38	13.76	11.52	7.63	8.75	9.45	9.49	10.61	11.31
20	.32	17.94	14.21	11.89	7.70	8.89	9.63	9.62	10.81	11.55

Table XI - Third Pair Power Distribution from AU to ISTE

Table XI also assumes that $R_p = 25\Omega$ and $R_c = 0.2\Omega$.

ISDN BRI instruments are limited to drawing a maximum of 1W for phantom powering and 7W for third pair powering. It is desirable, however, to provide 5W for phantom powering because of the higher speed of the interface and to provide for higher functionality in the telephone instrument. It is also desirable to limit the maximum power required to be available to each ISTE in consideration of the size and cost of a central power

source. Therefore, although the present invention is able to operate at higher or lower powers for either phantom or third pair powering, the optimum maximum power limit appears to be 5W for phantom powering and 5W for third pair
5 powering.

From the above description, it is apparent that the present invention provides a power subsystem and method for providing phantom power and third pair power via a computer network bus, the bus including first and second conductors.
10 The phantom power subsystem comprises: (1) a power supply having a positive output and a negative output, the power supply adapted to provide power via the positive and negative outputs and (2) first and second transformers, each of the first and second transformers having a winding,
15 each of the windings having a pair of end taps and a center tap, the first conductor coupled to the end taps of the winding of the first transformer to allow data communication therebetween, the second conductor coupled to the end taps of the winding of the second transformer to
20 allow data communication therebetween, the positive and negative outputs of the power supply coupled to the center taps of the windings of the first and second transformers, respectively, to allow the power supply to transmit the power, via the first and second transformers and the first
25 and second conductors, to equipment couplable to the first and second conductors.

Although the present invention and its advantages have been described in detail, those skilled in the art should understand that they can make various changes,

substitutions and alterations herein without departing from the spirit and scope of the invention in its broadest form.

WHAT IS CLAIMED IS:

1. A power subsystem for providing phantom power via
2 a computer network bus, said bus including first and second
3 conductors, said subsystem comprising:
4 a power supply having a positive output and a negative
5 output, said power supply adapted to provide power via said
6 positive and negative outputs; and
7 first and second transformers, each of said first and
8 second transformers having a winding, each of said windings
9 having a pair of end taps and a center tap, said first
10 conductor coupled to said end taps of said winding of said
11 first transformer to allow data communication therebetween,
12 said second conductor coupled to said end taps of said
13 winding of said second transformer to allow data
14 communication therebetween, said positive and negative
15 outputs of said power supply coupled to said center taps of
16 said windings of said first and second transformers,
17 respectively, to allow said power supply to transmit said
18 power, via said first and second transformers and said
19 first and second conductors, to equipment couplable to said
20 first and second conductors.

2. The subsystem as recited in Claim 1 further comprising third and fourth transformers, each of said third and fourth transformers having a winding, each of said windings having a pair of end taps and a center tap, said first conductor coupled to said end taps of said winding of said third transformer to allow data communication therebetween, said second conductor coupled to said end taps of said winding of said fourth transformer to allow data communication therebetween, said positive and negative inputs of equipment coupled to said center taps of said windings of said third and fourth transformers, respectively, to allow said power supply to transmit said power, via said first and second transformers, said first and second conductors and said third and fourth transformers, to said equipment.

3. The subsystem as recited in Claim 1 wherein said bus comprises a two-pair twisted-pair bus selected from the group consisting of:

4 10Base-T,
5 Ethernet[®],
6 Token Ring[®],
7 ATM,
8 100Base-T, and
9 isoEthernet[®].

4. The subsystem as recited in Claim 1 wherein connectors are interspersed along a length of said conductors.

5. The subsystem as recited in Claim 1 wherein said
2 power supply is a DC power supply.

6. The subsystem as recited in Claim 1 wherein each
2 of said first and second transformers has a second winding,
3 said second windings coupled to respective filter circuits.

7. The subsystem as recited in Claim 1 further
2 comprising a protective device coupled to said power supply
3 to prevent power exceeding a desired amount from passing
4 through said protective device.

8. The subsystem as recited in Claim 1 wherein said
2 power is supplied at about 48 volts.

9. The subsystem as recited in Claim 1 wherein said
2 equipment is coupled to a voice instrument, said power
3 supply thereby providing power to said voice instrument.

10. The subsystem as recited in Claim 1 wherein said
2 equipment is an Integrated Services Terminal Equipment
3 (ISTE) device.

11. A method of providing phantom power via a
2 computer network bus, said bus including first and second
3 conductors, said method comprising the steps of:
4 providing power via a positive output and a negative
5 output of a power supply; and
6 transmitting said power through first and second
7 transformers, each of said first and second transformers
8 having a winding, each of said windings having a pair of
9 end taps and a center tap, said first conductor coupled to
10 said end taps of said winding of said first transformer to
11 allow data communication therebetween, said second
12 conductor coupled to said end taps of said winding of said
13 second transformer to allow data communication
14 therebetween, said positive and negative outputs of said
15 power supply coupled to said center taps of said windings
16 of said first and second transformers, respectively, to
17 allow said power supply to transmit said power, via said
18 first and second transformers and said first and second
19 conductors, to equipment couplable to said first and second
20 conductors.

12. The method as recited in Claim 11 further
2 comprising the step of transmitting said power through
3 third and fourth transformers, each of said third and
4 fourth transformers having a winding, each of said windings
5 having a pair of end taps and a center tap, said first
6 conductor coupled to said end taps of said winding of said
7 third transformer to allow data communication therebetween,
8 said second conductor coupled to said end taps of said
9 winding of said fourth transformer to allow data
10 communication therebetween, said positive and negative
11 inputs of equipment coupled to said center taps of said
12 windings of said third and fourth transformers,
13 respectively, to allow said power supply to transmit said
14 power, via said first and second transformers, said first
15 and second conductors and said third and fourth
16 transformers, to said equipment.

13. The method as recited in Claim 11 wherein said
2 bus comprises a two-pair twisted-pair bus selected from the
3 group consisting of:
4 10Base-T,
5 Ethernet[®],
6 Token Ring[®],
7 ATM,
8 100Base-T, and
9 isoEthernet[®].

14. The method as recited in Claim 11 wherein said
2 connectors are interspersed along a length of said
3 conductors.

15. The method as recited in Claim 11 wherein said
2 power supply is a DC power supply.

16. The method as recited in Claim 11 further
2 comprising the step of coupling second windings of each of
3 said first and second transformers to respective filter
4 circuits.

17. The method as recited in Claim 11 further
2 comprising the step of preventing power exceeding a desired
3 amount from passing through a protective device coupled to
4 said power supply.

18. The method as recited in Claim 11 further
2 comprising the step of supplying said power at about 48
3 volts.

19. The method as recited in Claim 11 wherein said
2 equipment is coupled to a voice instrument, said power
3 supply thereby providing power to said voice instrument.

20. The method as recited in Claim 11 wherein said
2 equipment is an Integrated Services Terminal Equipment
3 (ISTE) device.

21. A bus interface for a local area network (LAN),
2 comprising:
3 an isolation transformer having a primary winding and
4 a secondary winding, said primary winding having first and
5 second end taps and first and second center taps, said
6 secondary winding having first and second end taps, said
7 first and second end taps of said primary winding adapted
8 to be coupled to a bus of said LAN, said first and second
9 end taps of said secondary winding adapted to be coupled to
10 a data input of equipment, said first and second center
11 taps of said primary winding cooperating to provide a power
12 output adapted to be coupled to a power input of said
13 equipment to provide a voltage reference therefor, said
14 isolation transformer substantially preventing said voltage
15 reference from DC-biasing said secondary winding, said
16 power output forming a portion of a power supply for said
17 equipment.

22. The interface as recited in Claim 21 further
2 comprising:

3 a second isolation transformer having a primary
4 winding and a secondary winding, said primary winding of
5 said second isolation transformer having first and second
6 end taps and first and second center taps, said secondary
7 winding of said second isolation transformer having first
8 and second end taps, said first and second end taps of said
9 primary winding of said second isolation transformer
10 adapted to be coupled to said bus of said LAN, said first
11 and second end taps of said secondary winding of said
12 second isolation transformer adapted to be coupled to said
13 data input of said equipment, said first and second center
14 taps of said primary winding of said second isolation
15 transformer cooperating to provide a second power output
16 adapted to be coupled to said power input of said equipment
17 to provide a second voltage reference therefor, said second
18 isolation transformer substantially preventing said voltage
19 reference from DC-biasing said secondary winding of said
20 second isolation transformer, said voltage reference and
21 said second voltage reference cooperating to form said
22 power supply for said equipment.

23. The interface as recited in Claim 21 wherein said
2 LAN is a Token Ring® LAN.

24. The interface as recited in Claim 21 wherein said
2 equipment is coupled to a voice instrument, said power
3 supply thereby providing power to said voice instrument.

25. The interface as recited in Claim 21 wherein said
2 isolation transformer is capable of communicating video and
3 voice data.

26. The interface as recited in Claim 21 wherein said
2 bus comprises two twisted-pair conductors.

27. The interface as recited in Claim 21 wherein said
2 bus comprises a two-pair twisted-pair bus selected from the
3 group consisting of:

4 10Base-T,
5 Ethernet[®],
6 Token Ring[®],
7 ATM,
8 100Base-T, and
9 isoEthernet[®].

28. The interface as recited in Claim 21 wherein said
2 first and second end taps of said secondary winding are
3 adapted to be coupled to said data input of said equipment
4 via a filter circuit.

29. The interface as recited in Claim 21 wherein said
2 equipment is an Integrated Services Terminal Equipment
3 (ISTE) device.

30. The interface as recited in Claim 22 further
2 comprising a shunt capacitor coupling said power output and
3 said second power output.

31. A method of providing an interface for a local
2 area network (LAN), comprising the steps of:

3 providing an isolation transformer having a primary
4 winding and a secondary winding, said primary winding
5 having first and second end taps and first and second
6 center taps, said secondary winding having first and second
7 end taps, said first and second end taps of said primary
8 winding adapted to be coupled to a bus of said LAN, said
9 first and second end taps of said secondary winding adapted
10 to be coupled to a data input of equipment; and

11 coupling said first and second center taps of said
12 primary winding to a power output adapted to be coupled to
13 a power input of said equipment to provide a voltage
14 reference therefor, said isolation transformer
15 substantially preventing said voltage reference from DC-
16 biasing said secondary winding, said power output forming
17 a portion of a power supply for said equipment.

32. The method as recited in Claim 31 further
2 comprising the steps of:

3 providing a second isolation transformer having a
4 primary winding and a secondary winding, said primary
5 winding of said second isolation transformer having first
6 and second end taps and first and second center taps, said
7 secondary winding of said second isolation transformer
8 having first and second end taps, said first and second end
9 taps of said primary winding of said second isolation
10 transformer adapted to be coupled to said bus of said LAN,
11 said first and second end taps of said secondary winding of
12 said second isolation transformer adapted to be coupled to
13 said data input of said equipment; and

14 coupling said first and second center taps of said
15 primary winding of said second isolation transformer to a
16 second power output adapted to be coupled to said power
17 input of said equipment to provide a second voltage
18 reference therefor, said second isolation transformer
19 substantially preventing said voltage reference from DC-
20 biasing said secondary winding of said second isolation
21 transformer, said voltage reference and said second voltage
22 reference cooperating to form said power supply for said
23 equipment.

33. The method as recited in Claim 31 LAN is a Token
2 Ring[®] LAN.

34. The method as recited in Claim 31 wherein said
2 equipment is coupled to a voice instrument, said power
3 supply thereby providing power to said voice instrument.

35. The method as recited in Claim 31 further
2 comprising the step of communicating video and voice data
3 across said isolation transformer.

36. The method as recited in Claim 31 wherein said
2 bus comprises two twisted-pair conductors.

37. The method as recited in Claim 31 wherein said
2 bus comprises a two-pair twisted-pair bus selected from the
3 group consisting of:

4 10Base-T,
5 Ethernet[®],
6 Token Ring[®],
7 ATM,
8 100Base-T, and
9 isoEthernet[®].

38. The method as recited in Claim 31 further
2 comprising the step of coupling said first and second end
3 taps of said secondary winding to said data input of said
4 equipment via a filter circuit.

39. The method as recited in Claim 31 wherein said
2 equipment is an Integrated Services Terminal Equipment
3 (ISTE) device.

40. The method as recited in Claim 32 further
2 comprising the step of coupling a shunt capacitor between
3 said power output and said second power output.

41. A power subsystem for providing third pair power
2 to equipment coupled to a computer network bus, said bus
3 including first and second conductors, said subsystem
4 comprising:
5 a power supply having a positive output and a negative
6 output, said power supply adapted to provide power via said
7 positive and negative outputs; and
8 third pair conductors coupled to said positive and
9 negative outputs, respectively, said third pair conductors
10 adapted to deliver said power to said equipment coupled to
11 said first and second conductors and said third pair
12 conductors.

42. The subsystem as recited in Claim 41 wherein said
2 equipment is coupled to a voice instrument, said power
3 supply thereby providing power to said voice instrument.

43. The subsystem as recited in Claim 41 wherein said
2 bus comprises a two-pair twisted-pair bus selected from the
3 group consisting of:

4 10Base-T,
5 Ethernet[®],
6 Token Ring[®],
7 ATM,
8 100Base-T, and
9 isoEthernet[®].

44. The subsystem as recited in Claim 41 wherein said
2 power is between about 1 watt and about 7 watts.

45. The subsystem as recited in Claim 41 wherein said
2 power supply is a DC power supply.

46. The subsystem as recited in Claim 41 wherein said
2 first and second conductors communicate data over a
3 computer network.

47. The subsystem as recited in Claim 41 further
2 comprising a protective device coupled to said power supply
3 to prevent power exceeding a desired amount from passing
4 through said protective device.

48. The subsystem as recited in Claim 41 wherein said
2 power is supplied at about 48 volts.

49. The subsystem as recited in Claim 41 wherein said
2 third pair conductors are twisted.

50. The subsystem as recited in Claim 41 wherein said
2 equipment is an Integrated Services Terminal Equipment
3 (ISTE) device.

51. A method of providing third pair power to
2 equipment coupled to a computer network bus, said bus
3 including first and second conductors, said method
4 comprising the steps of:
5 providing power via a positive output and a negative
6 output of a power supply; and
7 transmitting said power through third pair conductors
8 coupled to said positive and negative outputs,
9 respectively, said third pair conductors adapted to deliver
10 said power to said equipment coupled to said first and
11 second conductors and said third pair conductors.

52. The method as recited in Claim 51 further
2 comprising the step of coupling said equipment to a voice
3 instrument, said power supply thereby providing power to
4 said voice instrument.

53. The method as recited in Claim 51 wherein said
2 bus comprises a two-pair twisted-pair bus selected from the
3 group consisting of:
4 10Base-T,
5 Ethernet[®],
6 Token Ring[®],
7 ATM,
8 100Base-T, and
9 isoEthernet[®].

54. The method as recited in Claim 51 further
2 comprising the step of delivering said power at a wattage
3 between about 1 watt and about 7 watts.

55. The method as recited in Claim 51 further
2 comprising the step of providing DC power from said power
3 supply.

56. The method as recited in Claim 51 further
2 comprising the step of communicating data over a computer
3 network with said first and second conductors.

57. The method as recited in Claim 51 further
2 comprising the step of preventing power exceeding a desired
3 amount from passing through a protective device coupled to
4 said power supply.

58. The method as recited in Claim 51 further
2 comprising the step of supplying said power at about 48
3 volts.

59. The method as recited in Claim 51 wherein said
2 third pair conductors are twisted.

60. The method as recited in Claim 51 wherein said
2 equipment is an Integrated Services Terminal Equipment
3 (ISTE) device.

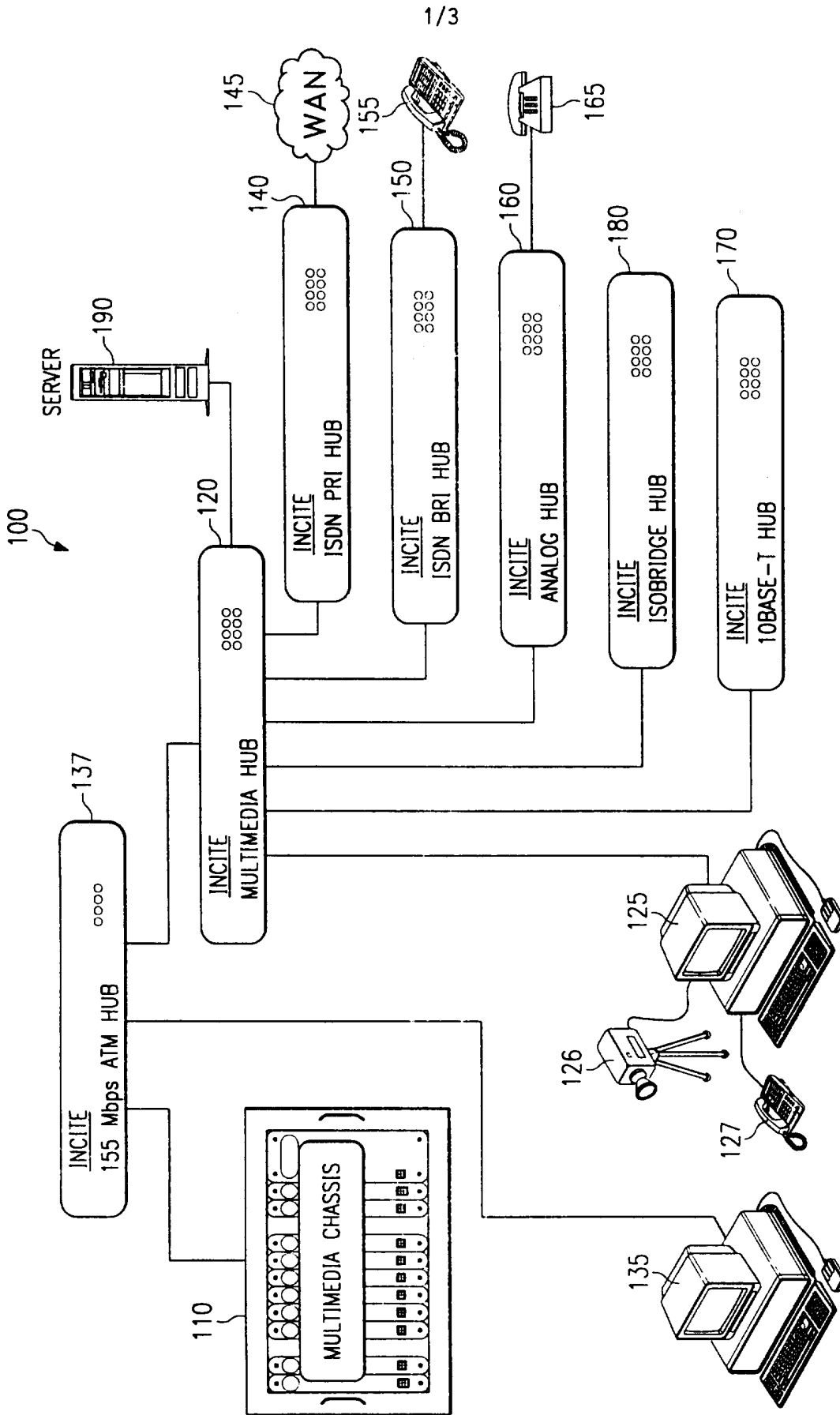

FIG. 1

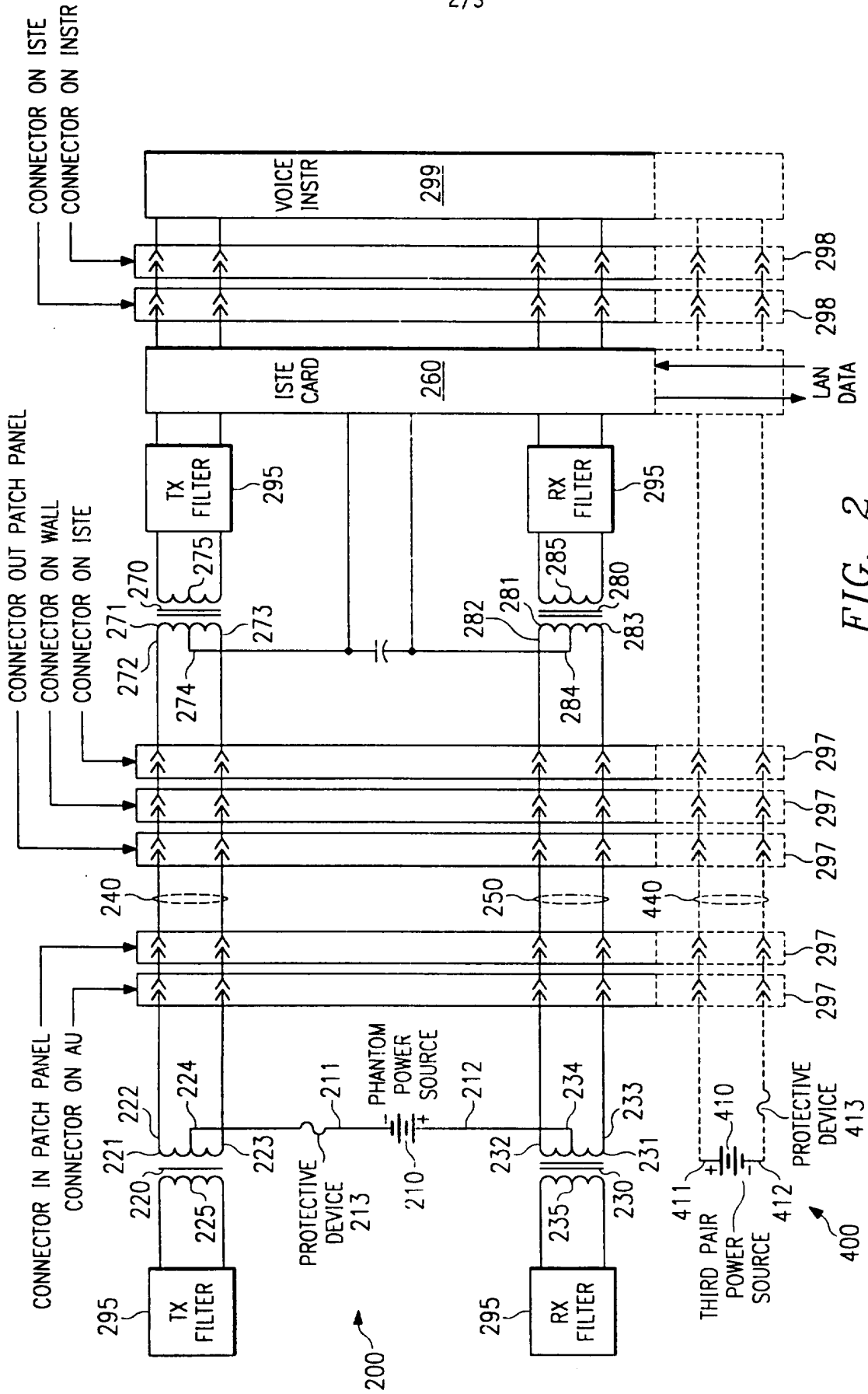

FIG. 2

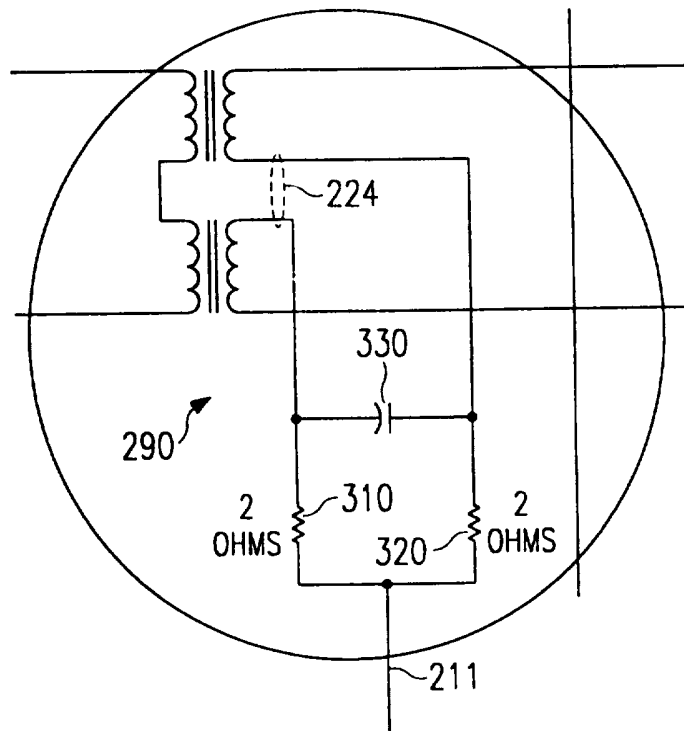

FIG. 3

INTERNATIONAL SEARCH REPORT

International Application No
PCT/IB 96/00223

A. CLASSIFICATION OF SUBJECT MATTER
IPC 6 H04L12/10 H04Q11/04 H04M19/08

According to International Patent Classification (IPC) or to both national classification and IPC

B. FIELDS SEARCHED

Minimum documentation searched (classification system followed by classification symbols)
IPC 6 H04M H04L H04Q

Documentation searched other than minimum documentation to the extent that such documents are included in the fields searched

Electronic data base consulted during the international search (name of data base and, where practical, search terms used)

C. DOCUMENTS CONSIDERED TO BE RELEVANT

Category *	Citation of document, with indication, where appropriate, of the relevant passages	Relevant to claim No.
X A	US,A,4 733 389 (PUVOGEL) 22 March 1988 see abstract; figure 2 ---	1,3-11, 13-40 2,12, 41-60
X A	WO,A,92 17968 (ECHELON CORPORATION) 15 October 1992 see the whole document ---	1,3-11, 13-40 2,12, 41-60
A	EP,A,0 307 781 (TELIC ALCATEL) 22 March 1989 see abstract; figure 1 ---	1-60
A	EP,A,0 384 259 (GEN INSTR CORP) 29 August 1990 see abstract; figure 1 ---	1-60
	-/--	

Further documents are listed in the continuation of box C.

Patent family members are listed in annex.

* Special categories of cited documents :

- *A* document defining the general state of the art which is not considered to be of particular relevance
- *E* earlier document but published on or after the international filing date
- *L* document which may throw doubts on priority claim(s) or which is cited to establish the publication date of another citation or other special reason (as specified)
- *O* document referring to an oral disclosure, use, exhibition or other means
- *P* document published prior to the international filing date but later than the priority date claimed

- *T* later document published after the international filing date or priority date and not in conflict with the application but cited to understand the principle or theory underlying the invention
- *X* document of particular relevance; the claimed invention cannot be considered novel or cannot be considered to involve an inventive step when the document is taken alone
- *Y* document of particular relevance; the claimed invention cannot be considered to involve an inventive step when the document is combined with one or more other such documents, such combination being obvious to a person skilled in the art.
- *&* document member of the same patent family

Date of the actual completion of the international search

21 June 1996

Date of mailing of the international search report

08.07.96

Name and mailing address of the ISA

European Patent Office, P.B. 5818 Patentlaan 2
NL - 2280 HV Rijswijk
Tel. (+ 31-70) 340-2040, Tx. 31 651 epo nl,
Fax (+ 31-70) 340-3016

Authorized officer

Montalbano, F

INTERNATIONAL SEARCH REPORT

International Application No
PCT/IB 96/00223

C.(Continuation) DOCUMENTS CONSIDERED TO BE RELEVANT

Category *	Citation of document, with indication, where appropriate, of the relevant passages	Relevant to claim No.
A	US,A,5 267 238 (YANO ET AL.) 30 November 1993 see the whole document ---	1-60
A	EP,A,0 590 242 (DETEWE) 6 April 1994 see the whole document ---	1-60
A	COMPCON SPRING '93, 22 - 26 February 1993, SAN FRANCISCO, CA, USA, pages 49-58, XP000379028 C.A.NORONHA ET AL.: "The evolution of campus network towards multimedia" see the whole document -----	

INTERNATIONAL SEARCH REPORT

Information on patent family members

International Application No
PCT/IB 96/00223

Patent document cited in search report	Publication date	Patent family member(s)	Publication date
US-A-4733389	22-03-88	NONE	
WO-A-9217968	15-10-92	US-A- 5148144	15-09-92
		AU-B- 1676892	02-11-92
		EP-A- 0577767	12-01-94
EP-A-307781	22-03-89	FR-A- 2620291	10-03-89
		DE-A- 3878105	18-03-93
		IE-B- 61599	16-11-94
		US-A- 4953055	28-08-90
EP-A-384259	29-08-90	US-A- 4937811	26-06-90
		CA-A- 2002782	24-08-90
US-A-5267238	30-11-93	JP-A- 4196844	16-07-92
		JP-A- 4192642	10-07-92
EP-A-590242	06-04-94	DE-A- 4233682	07-04-94