



(72) LADOUCEUR, HAROLD A., US

(71) FABRISTEEL PRODUCTS, INC., US

(51) Int.Cl.⁷ F16B 37/04, F16B 39/00

(30) 1997/08/04 (08/905,305) US

(54) **ELEMENT DE FIXATION A RIVETAGE AUTOMATIQUE**

(54) **SELF-RIVETING FASTENING ELEMENT**

(57) L'invention se rapporte à un élément de fixation à rivetage automatique destiné à être fixé de manière permanente à un panneau métallique, dans un orifice de ce dernier, au moyen d'une filière présentant une cavité concave annulaire. Ledit élément de fixation comporte une partie de rivetage tubulaire, une partie bride radiale et une partie de fixation. Les surfaces interne et externe de la partie de rivetage tubulaire sont inclinées de manière relativement uniforme en direction de la partie bride radiale de sorte que l'épaisseur de la partie de rivetage tubulaire, au niveau de son extrémité libre, soit inférieure à l'épaisseur adjacente à la partie bride radiale. Selon le mode de réalisation préféré, la surface interne de la partie de rivetage tubulaire est cylindrique et sa surface externe s'effilant vers l'intérieur en vue de former un cône orienté vers ladite extrémité libre et ce, aux fins de réduire la force nécessaire pour déformer dans le sens radial, et vers l'extérieur, l'extrémité libre de la partie tubulaire. En outre, la surface externe de la partie bride radiale est généralement polygonale et présente des surfaces latérales concaves courbées dans le sens radial et vers l'intérieur, ces surfaces étant séparées par des surfaces périphériques courbées et convexes relativement minces, ce qui permet de réduire la force nécessaire pour entraîner la partie bride dans le panneau au cours de l'installation finale de l'élément de fixation.

(57) An improved self-riveting fastening element for permanent attachment to a metal panel within a panel opening by a die member having an annular concave die cavity. The fastening element includes a tubular riveting portion and a radial flange portion and a fastening portion. The internal and external surfaces of the tubular riveting portion are relatively uniformly inclined toward the radial flange portion such that the thickness of the tubular riveting portion at the free end is less than the thickness adjacent the radial flange portion. In the preferred embodiment, the internal surface of the tubular riveting portion is cylindrical and the external surface is slightly conical tapering inwardly toward the free end to reduce the force required to radially deform the free end of the tubular portion radially outwardly. Further, the outer surface of the radial flange portion is generally polygonal having arcuately radially inwardly concave side surfaces spaced by relative thin convex arcuate edge surfaces reducing the force required to drive the flange portion into the panel during final installation of the fastening element.

PCTWORLD INTELLECTUAL PROPERTY ORGANIZATION
International Bureau

INTERNATIONAL APPLICATION PUBLISHED UNDER THE PATENT COOPERATION TREATY (PCT)

(51) International Patent Classification ⁶ : F16B	A2	(11) International Publication Number: WO 99/06716 (43) International Publication Date: 11 February 1999 (11.02.99)
(21) International Application Number: PCT/US98/16098 (22) International Filing Date: 3 August 1998 (03.08.98) (30) Priority Data: 08/905,305 4 August 1997 (04.08.97) US (71) Applicant: FABRISTEEL PRODUCTS, INC. [US/US]; 22900 West Eight Mile Road, Southfield, MI 48034 (US). (72) Inventor: LADOUCEUR, Harold, A.; 30123 Bentley, Livonia, MI 48154 (US). (74) Agents: HONAKER, William, H. et al.; Howard & Howard Attorneys, P.C., Suite 101, 1400 North Woodward Avenue, Bloomfield Hills, MI 48304 (US).		(81) Designated States: AL, AM, AT, AU, AZ, BA, BB, BG, BR, BY, CA, CH, CN, CU, CZ, DE, DK, EE, ES, FI, GB, GE, GH, GM, HR, HU, ID, IL, IS, JP, KE, KG, KP, KR, KZ, LC, LK, LR, LS, LT, LU, LV, MD, MG, MK, MN, MW, MX, NO, NZ, PL, PT, RO, RU, SD, SE, SG, SI, SK, SL, TJ, TM, TR, TT, UA, UG, UZ, VN, YU, ZW, ARIPO patent (GH, GM, KE, LS, MW, SD, SZ, UG, ZW), Eurasian patent (AM, AZ, BY, KG, KZ, MD, RU, TJ, TM), European patent (AT, BE, CH, CY, DE, DK, ES, FI, FR, GB, GR, IE, IT, LU, MC, NL, PT, SE), OAPI patent (BF, BJ, CF, CG, CI, CM, GA, GN, GW, ML, MR, NE, SN, TD, TG). Published <i>Without international search report and to be republished upon receipt of that report.</i>
(54) Title: SELF-RIVETING FASTENING ELEMENT		
(57) Abstract An improved self-riveting fastening element for permanent attachment to a metal panel within a panel opening by a die member having an annular concave die cavity. The fastening element includes a tubular riveting portion and a radial flange portion and a fastening portion. The internal and external surfaces of the tubular riveting portion are relatively uniformly inclined toward the radial flange portion such that the thickness of the tubular riveting portion at the free end is less than the thickness adjacent the radial flange portion. In the preferred embodiment, the internal surface of the tubular riveting portion is cylindrical and the external surface is slightly conical tapering inwardly toward the free end to reduce the force required to radially deform the free end of the tubular portion radially outwardly. Further, the outer surface of the radial flange portion is generally polygonal having arcuately radially inwardly concave side surfaces spaced by relative thin convex arcuate edge surfaces reducing the force required to drive the flange portion into the panel during final installation of the fastening element.		

SELF-RIVETING FASTENING ELEMENT

FIELD OF THE INVENTION

5 The present invention relates to an improved self-riveting or self-
attaching fastening element, preferably a self-riveting male fastening element
such as a stud, bolt or the like, which is permanently attached to a panel in
an opening in the panel. More specifically, the present invention relates to
a self-riveting fastening element having a tubular riveting portion which is
10 received through an opening in the panel into a concave annular die cavity to
permanently rivet the fastening element to the panel.

BACKGROUND OF THE INVENTION

15 Self-riveting male fastening elements of the type disclosed herein were
first developed by Profil Verbindungstechnik GmbH & Co. KG of Germany,
a company related to the assignee of the present application, as disclosed in
U.S. Patent No. 5,092,724. The fastening element includes a tubular or
annular piercing and riveting portion or barrel portion which in the preferred
20 embodiment pierced an opening in the panel which is then received through
the panel opening into a die member having an annular concave die cavity.
The die then deforms the free end of the barrel or riveting portion radially
outwardly to permanently attach the fastening element to the panel. The
fastening element further includes a radial flange portion which is driven into
25 the panel as the free end of the tubular riveting portion is deformed radially
outwardly forming a rigid secure installation in a panel. In the preferred
embodiment, the fastening element further includes a male fastening portion
integral with the radial flange or body portion coaxially aligned with the
tubular riveting portion. Female fastening elements of this type were also
30 developed, wherein the body portion includes an internal thread forming a

nut-type fastener. Alternatively, the bore may be smooth to receive a self-rolling or self-tapping screw or bolt.

5 Self-attaching fastening elements of this type have been used extensively particularly in automotive and other applications requiring a secure rigid installation of a fastening element such as a stud, bolt, or nut in a metal panel or plate including body panels, brackets, structural elements and the like. However, self-piercing fastening elements of this type are generally limited to applications where the metal panel has a thickness generally less than about 2.5 mm or 0.098 inches. In automotive applications for example 10 one problem solved by the self-piercing fastener disclosed in the above-referenced U.S. patent was to permanently attach a fastening element in relatively thin panels having a thickness of about 0.031 inches in a continuous operation. Later, fastening elements of this type were developed for permanent attachment of the fastening elements in relatively thick or heavy 15 gauge metal panels as disclosed, for example, in U.S. Patent Nos. 4,713,872; 5,237,733; and 5,564,873. In applications requiring the installation of a self-riveting fastening element of this type in heavy gauge metal panels having a thickness ranging from about 0.08 to 0.25 inches or greater, an opening configured to receive the tubular riveting portion of the fastening element is 20 first formed in the panel. The tubular riveting portion of the fastening element is then received through the panel opening into a concave annular die cavity and the fastening element is then driven toward the die member which deforms the free end of the tubular riveting portion radially outwardly, permanently riveting the fastening element to the panel. The fastening 25 element may include a radial flange portion which is driven into the panel to entrap the panel portion adjacent the panel opening and forming a flush mounting as disclosed in U.S. Patent Nos. 5,237,733 and 5,564,873. Alternatively, the body portion may include a conical surface adjacent the tubular riveting portion forming a press fit as disclosed in U.S. Patent No. 30 4,713,872. In the most preferred embodiment, however, the body portion

includes a radial flange portion forming a more secure rigid fastener and panel assembly.

5 There are, however, problems in the installation of a self-riveting fastening element of the type described having a radial flange portion for installation in heavier gauge metal panels, particularly, but not exclusively male self-riveting fastening elements. A male self-riveting fastening element, for example, is driven toward the die member by a plunger having an annular end portion which surrounds the male fastening portion as disclosed in the above-referenced U.S. patents. The annular driving surface of the plunger is
10 driven against an annular surface of the radial flange portion of the body portion of the fastening element which significantly deforms the radial flange portion during installation as shown in Figure 9, described below, because of the force required for installation. As described in the above-referenced U.S. patents, self-riveting fasteners of this type are normally installed in a die press generating several tons of force and the die press may simultaneously form
15 the plate or panel into a contoured shape. Several tons of force are required first to deform the free end of the tubular riveting or barrel portion radially outwardly in the concave arcuate annular die cavity, because of the extreme frictional resistance and large hoop stresses developed. These forces have been reduced by including an internal conical chamfer surface on the free end
20 of the self-riveting portion and by friction resistant coatings; however, these approaches have not eliminated this problem. Further, the force required to deform the radial flange portion of the self-riveting fastening element into the panel results in further deformation of the radial flange portion during the
25 final installation of the fastening element in the panel.

During installation of a self-riveting fastening element of the type described above, the radial flange portion is deformed by the driving surface of the plunger or ram toward and into the tubular riveting portion and radially, resulting in resulted in fewer structural integrity of the fastening
30 element and panel assembly. This problem has reduced applications of this

type of self-riveting fastening element in heavier gauge metal panels and problems following installation. As set forth below, this problem has been solved by the improved self-attaching fastening element of this invention by reducing the force required to install the self-riveting fastening element in a panel, thereby reducing the deformation of the radial flange portion during installation.

SUMMARY OF THE INVENTION

As described above, the improved self-riveting fastening element of this invention is designed for permanent attachment to a metal panel or plate within a panel opening by a die member having an annular concave die cavity. The self-riveting fastening element includes a tubular riveting portion having generally cylindrical internal and external surfaces and a free end. The self-riveting fastening element further includes a radial flange portion integral with the tubular riveting portion opposite the free end having a diameter greater than the tubular barrel portion and adapted to be driven into the panel as the tubular riveting portion is driven through the panel opening into the annular die cavity. Where the self-riveting fastening element is a male fastening element, the radial flange portion forms part of a body portion of the fastening element, which bridges the tubular riveting portion and closes the end of the tubular barrel portion opposite the free end and a male fastening portion such as a stud or bolt is integral with the flange or body portion opposite the tubular riveting portion and preferably coaxially aligned with the tubular riveting portion. An annular drive surface is thus defined around the male fastening portion. Where the self-riveting fastening element is installed in a preformed opening, as will be required for installation in heavier gauge panels, the tubular riveting portion is first aligned with the panel opening, then driven through the panel opening by a plunger into an annular concave die cavity of a die member. The die member then deforms

the free end of the tubular riveting portion radially outwardly preferably in a hook or U-shape and the radial flange portion is simultaneously driven into the panel entrapping the panel metal between the radially deformed hook-shaped riveting portion and the flange portion, forming a secured fastening element and panel assembly.

5 The force required to deform the free end of the tubular riveting portion in the concave die cavity is significantly reduced by reducing the thickness of the tubular riveting portion adjacent the free end, wherein the internal and external surfaces of the generally cylindrical tubular barrel portion are slightly inclined toward the radial flange portion, such that the thickness of the tubular riveting portion uniformly increases from the free end toward the radial flange portion. In the most preferred embodiment of the self-riveting fastening element of this invention, the internal surface of the tubular riveting portion is cylindrical and parallel to the longitudinal axis of the tubular riveting portion and the external surface is conically tapered toward the free end of the riveting portion. Most preferably, the free end of the tubular riveting portion includes an outer arcuate surface which smoothly blends into the conical external surface providing a smooth transition from the arcuate outer surface into the conical external surface. The cone angle of the external surface is between about one and five degrees or most preferably between two and three degrees. As described more fully below, this relatively simple modification of the tubular riveting portion results in a significant reduction in the force required to deform the free end of the tubular riveting portion radially outwardly of greater than ten percent. The reduction in force required is achieved without significantly reducing the strength of the deformed hook-shaped free end of the tubular riveting portion.

20 The force required to drive the radial flange portion of the self-riveting fastening of this invention into the panel is reduced by providing a plurality of arcuate radially inwardly concave surfaces on the radially outer or exterior surface of the radial flange portion. This modification reduces the area of the

radial flange portion driven into the panel adjacent the opening and further increases the torque required to turn the self-riveting fastening element relative to the panel following installation. Torque resistance is also an important feature of a self-riveting fastening element of the type described herein because the fastening element is utilized to attach a second element to the fastening element and panel assembly. For example, the self-riveting male fastening element of this invention may include an integral threaded bolt portion which extends from the panel. The bolt is then used to attach an automotive component, for example, to the fastening element and panel assembly which is secured in place by a conventional nut. During the engagement of the nut, however, the bolt may be subject to twisting forces, particularly where the nut is cross-threaded or a thread forming nut or bolt is used and a torque wrench is used. The fastening portion may therefore be subject to substantial torsional loads and must be able to withstand turning of the fastening element relative to the panel following installation. In the most preferred embodiment of the self-riveting fastening element, the radial flange portion is generally polygonal having, for example, six or eight sides. The radially inwardly concave surfaces are defined in the side surfaces of the polygonal radial flange portion located between the points or edges. In the most preferred embodiment, the "edges" of the polygonal radial flange portion include a thin convex arcuate surface and the radially inwardly concave surfaces are located between the thin convex arcuate surfaces of the edges. The radially inwardly concave surfaces between the concave arcuate surfaces most preferably have a relatively large radius. The radius of curvature of the concave arcuate surfaces is defined such that the arc is spaced from the external surface of the tubular riveting portion. In the most preferred embodiment, the radius of the arcuate radially inwardly concave surface is greater than the radius of the external surface of the tubular riveting portion.

Other advantages and meritorious features of the self-riveting fastening element of this invention and method of installation will be more fully

understood from the following description of the preferred embodiments, the claims and the appended drawings a brief description of which follows.

BRIEF DESCRIPTION OF THE DRAWINGS

5

Figure 1 is an end perspective view of a preferred embodiment of a self-riveting male fastening element of this invention;

Figure 2 is an end view of the embodiment of the self-riveting male fastening element shown in Figure 1;

10

Figure 3 is a partial side cross sectional view of Figure 2 in the direction of view arrows 3-3;

Figure 4 is a side partially cross sectioned view of the self-riveting male fastening element of Figures 1 to 3 with the fastener located in a panel opening supported on a die member prior to installation;

15

Figures 5 to 7 are side partially cross sectioned views of the self-riveting fastening element illustrated in Figures 1 to 4 illustrating the installation of the self-riveting male fastening element in a panel;

20

Figure 8 is a graph comparing the installation forces of the improved self-riveting fastening element of this invention with the prior self-riveting fastening element described above; and

Figure 9 is a partial side cross sectional view illustrating the installation of a fastening element in a panel which does not include the improvements claimed herein.

25

DESCRIPTION OF PREFERRED EMBODIMENTS

30

Figures 1 to 3 illustrate a preferred embodiment of the self-riveting male fastening element 20 of this invention. The self-riveting male fastening element 20 includes a tubular riveting or barrel portion 22, a polygonal radial flange portion 24 which forms a portion of the body portion 26 as shown in

Figure 3, and a male fastening portion 28 which in the disclosed embodiment is externally threaded at 30 as shown in Figures 1 and 3. The tubular riveting portion 22 includes a free end 32 having an arcuate outer surface 34 and an inner conical chamfered surface 36 as best shown in Figure 3. The tubular riveting portion 22 further includes an internal surface 38 and an external surface 40 which are generally cylindrical. The radial flange portion further includes an annular drive surface 42 which in the disclosed embodiment of the male self-riveting fastening element surrounds the male fastening portion 28. As best shown in Figure 2, the outer surface of the radial portion is generally polygonal, which in the disclosed embodiment includes eight "edges" 44 and eight side surfaces 46. As described, in the preferred embodiment of the self-riveting fastening element of this invention, the side surfaces 46 include arcuate radially inwardly concave surfaces having a relatively large radius.

The "edges" or corners 44 are most preferably thin convex arcuate surfaces; that is, the surfaces 44 have a relatively short arc length, but all have the same radius generated from the longitudinal axis A of the fastener. In an M10 fastener, for example, the arc length or "width" of the surfaces 44 will be 0.010 to 0.030 inches. These thin concave arcuate surfaces 44 are however important to the control of the fastener during installation. First, fasteners of this type are fed through a flexible plastic tube having an internal diameter only slightly larger than the diameter of the convex arcuate surfaces 44 and these surfaces therefore control the orientation of the fasteners in the feed tube and prevent cocking. Second, the concave arcuate surfaces 44 control the location and orientation of the fastener in the installation head, which is important to properly orient the fastener for installation. The radius of curvature of the concave arcuate surfaces 46 is defined such that the arc is preferably spaced from the external surface 40 of the tubular riveting portion 22, as shown in Figure 2. Finally, the concave arcuate surfaces 46 terminate short of the "edges," leaving the thin convex arcuate surfaces 44 for control of the fastener. In the preferred embodiment, the radius of the convex arcuate

surfaces 44 is greater than the radius of the external surface 40 of the tubular riveting portion 22.

Further, as described above, the generally cylindrical internal and external surfaces, 38 and 40, respectively, of the tubular barrel portion 22 are relatively uniformly inclined toward the radial flange portion 24 such that the thickness of the tubular riveting portion at the free end 32 uniformly increases toward the radial flange portion. Stated another way, the internal and external surfaces 38 and 40 converge toward the free end 32 of the tubular riveting portion 22. In the most preferred embodiment the internal surface 38 is cylindrical and parallel to the longitudinal axis A of the tubular barrel portion 22 and the self-riveting male fastening element 20 in this embodiment, and the external surface 40 is conical tapering inwardly toward the free end 32 and blending smoothly with the arcuate surface 34 as shown in Figure 3. The cone angle B is preferably between one and five degrees and most preferably between two and three degrees.

Having described a preferred embodiment of the self-riveting male fastening element of this invention, the function and advantages of the improved fastening element will be more fully understood from a description of the method of installation illustrated in Figures 4 to 7. As shown in Figure 4, an opening 50 is first formed in the panel 52 configured and adapted to receive the fastening element 20. In the embodiment shown, the opening 50 is cylindrical or circular having an internal diameter which is greater than the external diameter of the exterior surface 40 of the tubular riveting portion 22 and less than the diameter of the radial flange portion 24. The panel 52 is supported on a die member 54 having an annular concave die cavity 56 coaxially aligned with the opening in the panel. The die member further includes a central relief port 58 because the body portion 26 closes the end of the tubular riveting portion 22 opposite the free end 32 and the port 58 permits exhaust of air during installation of the fastening element 20. The fastening element 20 is installed by a plunger 60 which in the disclosed

-10-

embodiment includes a cylindrical opening 62 which receives the male stud or bolt portion 28 as shown in Figure 4. The free end of the plunger includes an annular driving surface 64 which engages the driven surface 42 of the radial flange portion during installation. As described above and more particularly in the above-referenced patents, the fastening element 20 is normally installed in a die press having an installation head attached to one platen of the die press (not shown) and the die member or die button 54 is installed in the opposite die platen. A fastening element is then installed with each stroke of the die press. During installation, the riveting portion 22 is disposed through the opening 50 of the panel 52 such that the inner conical chamfered surface 36 of the free end 32 of the riveting portion 22 engages an inner surface of the annular concave die cavity 56. The fastening element 20 is then ready for installation.

The annular driving surface 64 of the plunger 60 is then driven against the annular surface 42 of the radial flange portion 24 which drives the inner conical chamfered surface 36 of the free end 32 of the riveting portion 22 against the annular concave die cavity 56 as shown in Figure 5. This deforms the free end 32 of the riveting portion 22 radially outwardly as best shown in Figure 6. As the free end 32 of the tubular riveting portion is deformed further, the internal surface 38 of the tubular barrel portion 22 is deformed against the annular concave die cavity 56 creating very substantial frictional resistance to further deformation. Finally, as shown in Figure 7, the tubular riveting portion is deformed into a hook-shape 66 and the radial flange portion 24 is deformed into the panel 54 entrapping the portion 68 of the panel adjacent the panel opening. The radial flange portion 24 is not substantially deformed radially outwardly or axially during the final installation of the fastening element 20 in the panel 52, forming a very secure and rigid installation.

Figure 8 is a chart comparing sequentially the forces required to install the improved self-riveting fastening element of this invention with prior

fastening elements of this type. The X axis defines the travel of the plunger 60 in Figures 4 to 7 above. The Y axis defines the force in thousands of pounds required for the installation of the fastening element 20 in the panel 52. Thus, the force required to install the improved self-riveting male fastening element 20 described above is shown by the dashed line 70 and the force required to install an identical self-riveting male fastening element which does not include a conical exterior surface or relatively inclined interior and exterior surfaces (38 and 40) or a radial flange portion 24 having arcuate radially inwardly concave surfaces 46 is shown at 72. Otherwise, the fasteners tested were identical. First, it should be noted that the rate of increase of force required to install the improved self-riveting male fastening element 20 shown at 70 is relatively constant as compared to the force required to install a self-riveting male fastening element without the improvements as shown at 72. This is important because the force of the ram of a die press is generally constant. The arcuate line 74 represents one concave arcuate surface 56 of the die cavity which is plotted in Figure 8 to permit determination of the status of the installation of the self-riveting male fastening element 20. At point 76, the radial flange portion 24 is first driven into the panel 54 just following the installation step shown in Figure 6. The graph shown in Figure 8 thus permits a direct comparison of the improved self-riveting fastening element of this invention with a fastening element of this type which does not include the improvements claimed herein. More specifically, it should be noted from Figure 8 that the force required for installation of the self-riveting fastening element prior to point 76 results solely from the radial deformation of the tubular riveting portion 22. As noted above, the force indicated by line 70 is relatively constant and significantly less than the force required to install a similar fastening element which does not include a conical external surface 40. For example, at point 78, the force required to install the improved self-riveting fastening element 20 of this invention is about twelve thousand pounds compared to about

fifteen thousand pounds for a self-riveting fastening element which does not include a conical exterior surface 40 on the tubular riveting portion 22 or a tapered riveting portion. At point 80 where the radial flange portion 24 is being driven into the panel 52 and the free end of the radial flange portion 24 is deformed into the final hook-shape 66 as shown in Figure 7, the force is reduced from greater than thirty-eight thousand pounds to about thirty-two thousand pounds as a result of the arcuate radially inwardly concave surfaces 46 on the exterior surface of the radial flange portion. Stated another way, it takes ten percent less energy to install a fastener of the improved design. As described above, these reductions in the force required to install the self-riveting fastening element 20 results in substantially less deformation of the radial flange portion 24 during the installation of the self-riveting fastening element of this invention and an improved fastening element and panel assembly. The final force at 82 is identical because the installation is now complete as shown in Figures 7, wherein the radial flange portion 24, the entrapped portion 68 of the panel 52 and the hook-shape 66 is a metal to metal laminate. Any further force would result in an over-hit condition which should be avoided during installation.

Figure 9 illustrates the problems associated with an installation of a self-riveting fastening element 120 which does not include the improvements of this invention. That is, the tubular riveting portion does not include a conical exterior surface 40 and the flange does not include concave arcuate surfaces 46 between the convex arcuate edges 44 as described above in regard to Figures 1 to 7. The side surfaces are flat. Otherwise, the fastener 120 is identical to the fastener 20 described above. The force of installation of the self-riveting fastening element 120 is shown at 72 in Figure 8 as described above.

Figure 9 is similar to Figure 7 except that it shows only the right hand side of the assembly. The plunger 160 and die member 154 are identical to the plunger 60 and die member 54 shown in Figures 4 to 7. As described

-13-

above, the plunger 160 includes a bore 162 which receives the male threaded portion 128 of the fastening element 120. The male fastening portion 128 includes external threads 129 having a crest diameter slightly smaller than the internal diameter 162 of the plunger. As described above, the tubular barrel portion is deformed in the concave annular die surface 156 into a hook-shape 166 as the plunger drives the fastener 120 toward the die member 154. Further, the radial flange portion 124 is driven into the panel 152 as described. The greater force required to deform the tubular barrel portion into the hook-shaped end portion 166 and the greater force required to deform the flange portion 124 into the panel 152 as shown at 72 in Figure 8 (compared to 70 for the fastener 20), deforms the radial flange portion 124 both radially and axially. In actual installations, the radial flange portion 124 is deformed axially a distance C as shown in Figure 9. That is, the driven surface 142 was actually located at 125 prior to the installation, but this surface was deformed axially to the position shown in Figure 9. Further, the flange portion 124 is deformed radially outwardly as shown. This permanent deformation of the radial flange portion results in reduced structural integrity of the fastening element and panel assembly and fewer applications of this type of fastening element in heavier gauge metal panels.

As will be understood by those skilled in the art, various modifications may be made to the self-riveting fastening element of this invention within the purview of the appended claims. For example, various male fastening portions 28 may be utilized including, for example, an unthreaded stud or ball joint or the improvements disclosed herein may be utilized in connection with female fastening elements wherein a threaded or unthreaded bore is provided through the body portion 26 of the fastening element. Features of this invention may also be used in self-piercing and riveting fasteners of the type described above. The self-riveting fastening element of this invention is particularly, but not exclusively adapted for mass production applications such as utilized by the automotive and appliance industries, wherein the fastener

5 element may be installed, for example, in low carbon steel panels having a thickness ranging from about 0.08 to 0.25 inches or greater, such as SAE 1010 steel and the fastener may be formed of medium carbon steel, such as SAE 1035 steel and the fastener is preferably heat treated. As will be understood, however, the preferred material for the self-riveting fastening element of this invention will depend upon the application including the panel metal.

CLAIMS

1. A self-riveting male fastening element for permanent attachment to a panel within a panel opening by a die member having an annular concave die cavity, said self-riveting fastening element including a tubular riveting portion having generally cylindrical internal and external surfaces and a free end, a radial flange portion integral with said tubular riveting portion opposite said free end having a diameter greater than said panel opening adapted to be driven into said panel, and a male fastening portion integral with said flange portion opposite said tubular riveting portion, the improvement comprising said radial flange portion including a plurality of spaced arcuate radially inwardly concave surfaces reducing the force required to drive said flange portion into said panel and increasing the torque required to turn said self-riveting fastening element relative to said panel following installation.

15

2. The self-riveting male fastening element defined in Claim 1, wherein said radial flange portion is generally polygonal having a plurality of side surfaces separated by edges, said arcuately radially inwardly concave surfaces defined in said side surfaces of said radial flange portion between said edges.

20

3. The self-riveting male fastening element defined in Claim 2, wherein said polygonal radial flange portion has at least six side surfaces and

-16-

six edges and wherein said edges each have a narrow arcuate outer convex surface.

4. The self-riveting male fastening element defined in Claim 1,
5 wherein said generally cylindrical internal and external surfaces of said tubular riveting portion are relatively inclined toward said radial flange portion such that the thickness of said tubular riveting portion at said free end is less than the thickness adjacent said radial flange portion, thereby reducing the force required to radially deform said tubular riveting portion in said annular die
10 cavity.

5. The self-riveting male fastening element defined in Claim 4,
wherein said internal surface of said tubular riveting portion is cylindrical and parallel to the axis of said tubular riveting portion, and said external surface
15 is conical uniformly tapering toward said free end and said free end of said tubular riveting portion having an arcuate surface smoothly blending into said conical external surface.

6. The self-riveting male fastening element defined in Claim 5,
20 wherein said male fastening portion is a generally cylindrical stud portion having a diameter less than said radial flange portion and said radial flange portion including an annular surface surrounding said stud portion adapted to receive an annular driving member.

-17-

7. The self-riveting male fastening element defined in Claim 5, wherein the cone angle of said conical external surface of said tubular riveting portion is between one and five degrees.

5 8. A self-riveting fastening element for permanent attachment to a panel within a panel opening by a die member having an annular concave die cavity, said self-riveting fastening element including a tubular riveting portion having generally cylindrical internal and external surfaces and a free end, a radial flange portion integral with said tubular riveting portion opposite
10 said free end, said tubular riveting portion including an external surface having a diameter less than said panel opening and said radial flange portion having a diameter greater than said panel opening and adapted to be driven into said panel when said free end of said tubular riveting portion is deformed radially outwardly in said concave die cavity, said radial flange portion having
15 a polygonal side surface including at least six concave arcuate surfaces reducing the force required to drive said flange portion into said panel and increasing the torque required to turn said self-riveting fastening element relative to said panel following installation.

20 9. The self-riveting fastening element defined in Claim 8, wherein said generally cylindrical internal and external surfaces of said tubular riveting portion are slightly relatively inclined toward said radial flange portion such that the thickness of said tubular barrel portion at said free end is less than the

-18-

thickness adjacent said radial flange portion, thereby reducing the force required to initially deform said tubular riveting portion in said annular die cavity.

5 10. The self-riveting fastening element defined in Claim 9, wherein said internal surface of said tubular riveting portion is cylindrical and parallel to the axis of said tubular riveting portion and said external surface of said tubular riveting portion is conical uniformly tapering inwardly toward said free end and said free end of said tubular riveting portion having an arcuate
10 surface smoothly blending into said conical external surface.

 11. The self-riveting fastening element defined in Claim 8, wherein said polygonal side surface of said radial flange portion includes relatively thin convex arcuate surfaces and said concave arcuate surfaces are spaced by said
15 convex arcuate edge surfaces having a relatively large diameter spaced from said external surface of said tubular riveting portion.

 12. A self-riveting male fastening element for permanent attachment to a panel within a panel opening by a die member having an annular concave
20 die cavity, said self-riveting fastening element including a tubular riveting portion having a free end, a radial flange portion integral with said tubular riveting portion opposite said free end bridging said tubular riveting portion and having a diameter greater than said tubular riveting portion, a male

fastening portion integral with said radial flange portion opposite said tubular
riveting portion and coaxially aligned with said tubular riveting portion, said
tubular riveting portion having a cylindrical internal surface extending parallel
to the axis of said tubular riveting portion and a conical exterior surface
5 uniformly tapering toward said free end and blending smoothly with an
arcuate outer surface of said free end such that the thickness of said tubular
riveting portion at said free end is less than the thickness of said tubular
riveting portion adjacent said radial flange portion, thereby reducing the force
required to radially deform said tubular riveting portion in said annular die
10 cavity.

13. The self-riveting male fastening element defined in Claim 12,
wherein said flange portion includes a plurality of outer spaced arcuate
radially inwardly concave surfaces reducing the force required to drive said
15 flange portion into said panel and increasing the torque required to turn said
self-riveting male fastening element relative to said panel following
installation.

14. The self-riveting male fastening element defined in Claim 13,
20 wherein the outer surface of said radial flange portion is generally polygonal
having at least six side surfaces separated by edge surfaces, said arcuate
radially inwardly concave surfaces defined in each of said side surfaces of
said radial flange portion spaced by said edge surfaces.

-20-

15. The self-riveting male fastening element defined in Claim 13, wherein said edge surfaces are each defined by a thin convex arcuate surface separating said radially inwardly concave surfaces and said thin convex arcuate edge surfaces having the same radius of curvature.

5

16. A self-riveting male fastening element for permanently attachment to a panel within a panel opening by a die member having an annular concave die cavity, said self-riveting male fastening element including a tubular riveting portion having a free end, a radial flange portion integral with said tubular riveting portion opposite said free end and a male fastening portion integral with said radial flange portion opposite said tubular riveting portion, said tubular riveting portion having a diameter less than said panel opening for receipt through said panel opening into said annular die cavity for deforming said free end radially outwardly and said radial flange portion having a diameter greater than said panel opening adapted to be driven into said panel, said tubular riveting portion having generally cylindrical internal and external surfaces slightly uniformly relatively inclined toward said radial flange portion such that the thickness of said tubular riveting portion at said free end is less than the thickness of said tubular riveting portion adjacent said radial flange portion, thereby reducing the force required to initially deform said tubular riveting portion in said die cavity and said radial flange portion including a plurality of spaced arcuate radially inwardly concave arcuate surfaces reducing the force required to drive said flange portion into said

10

15

20

panel and increasing the torque required to turn said self-riveting male fastening element relative to said panel following installation.

17. The self-riveting male fastening element defined in Claim 16,
5 wherein the outer surfaces of said radial flange portion is generally polygonal having a plurality of side surfaces each having a radially inwardly concave surface.

18. The self-riveting male fastening element defined in Claim 16,
10 wherein said internal surface of said tubular barrel portion is cylindrical and parallel to the axis of said tubular barrel portion and said external surface being conical uniformly tapering inwardly toward said free end and said free end having an arcuate outer surface blending smoothly with said conical external surface.

15
19. The self-riveting male fastening element defined in Claim 16,
wherein the outer surface of said radial flange portion is polygonal having at least six side surfaces and six edge surfaces, said edge surfaces each defined by a relatively thin convex arcuate edge surface and said radially inwardly
20 concave surfaces defined in said side surfaces spaced by said convex arcuate edge surfaces.

20. The self-riveting male fastening element defined in Claim 19, wherein the radius of curvature of said convex arcuate surfaces is greater than the radius of said external surface of said tubular riveting portion.

Fig-1

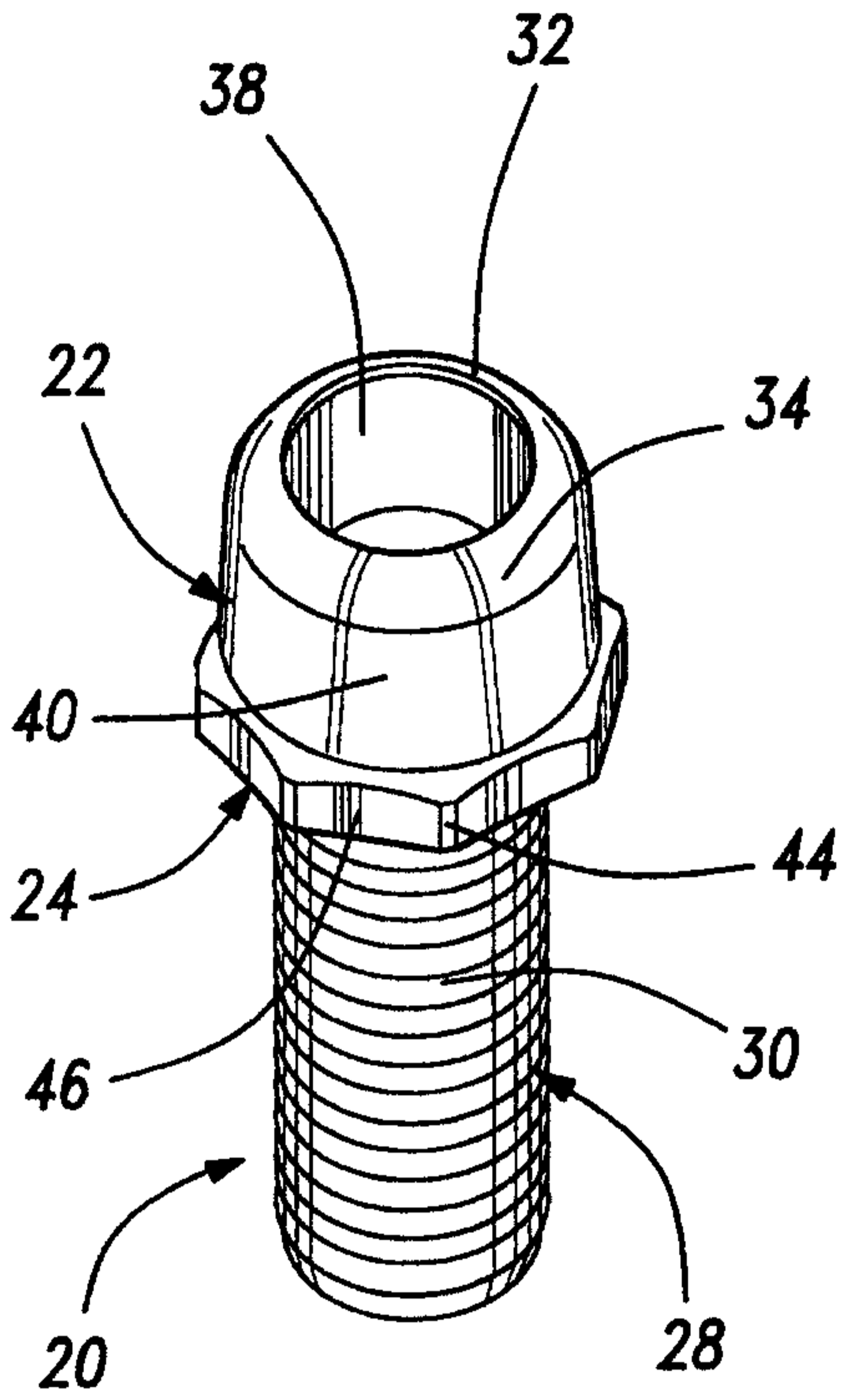

Fig-2

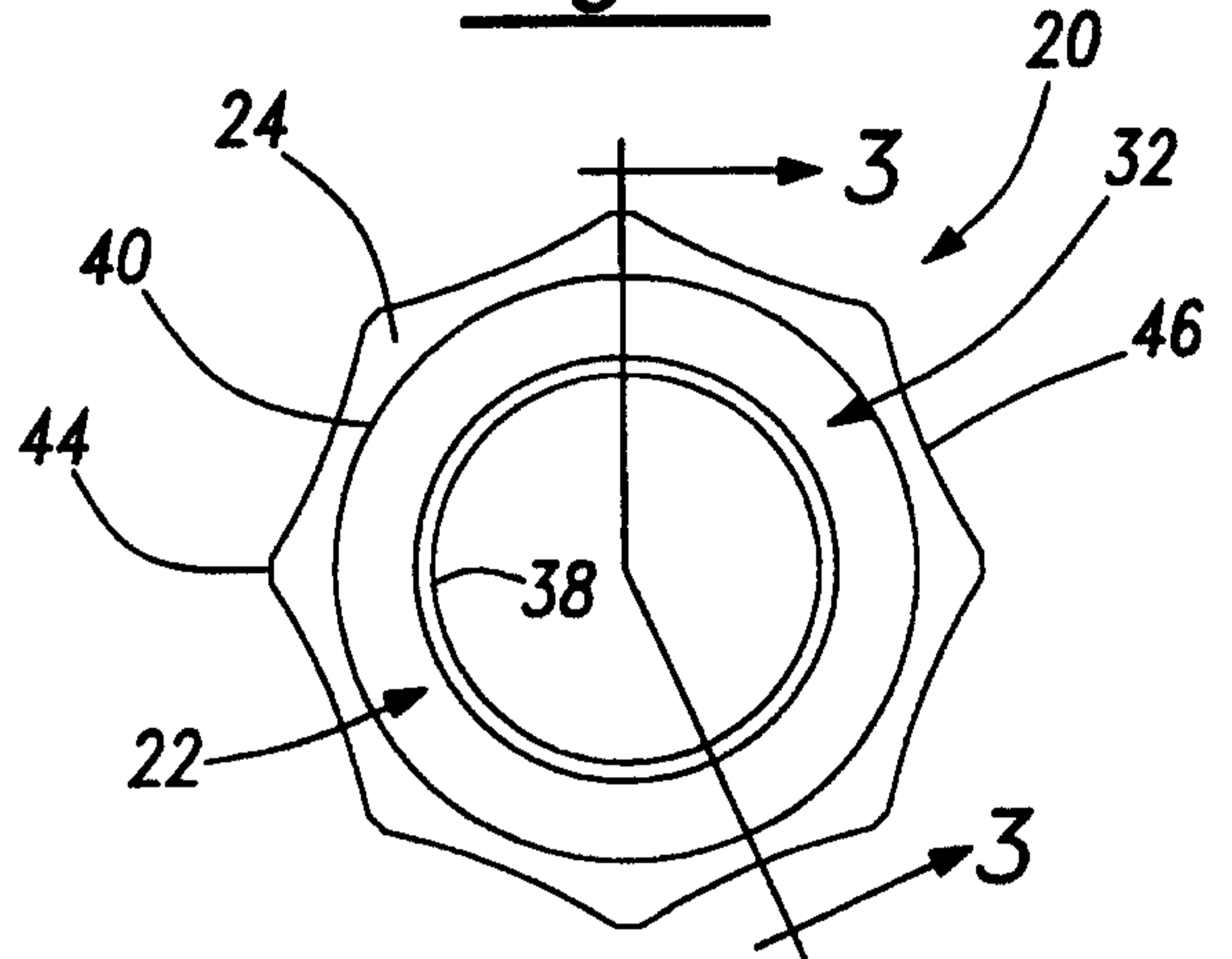

Fig-3

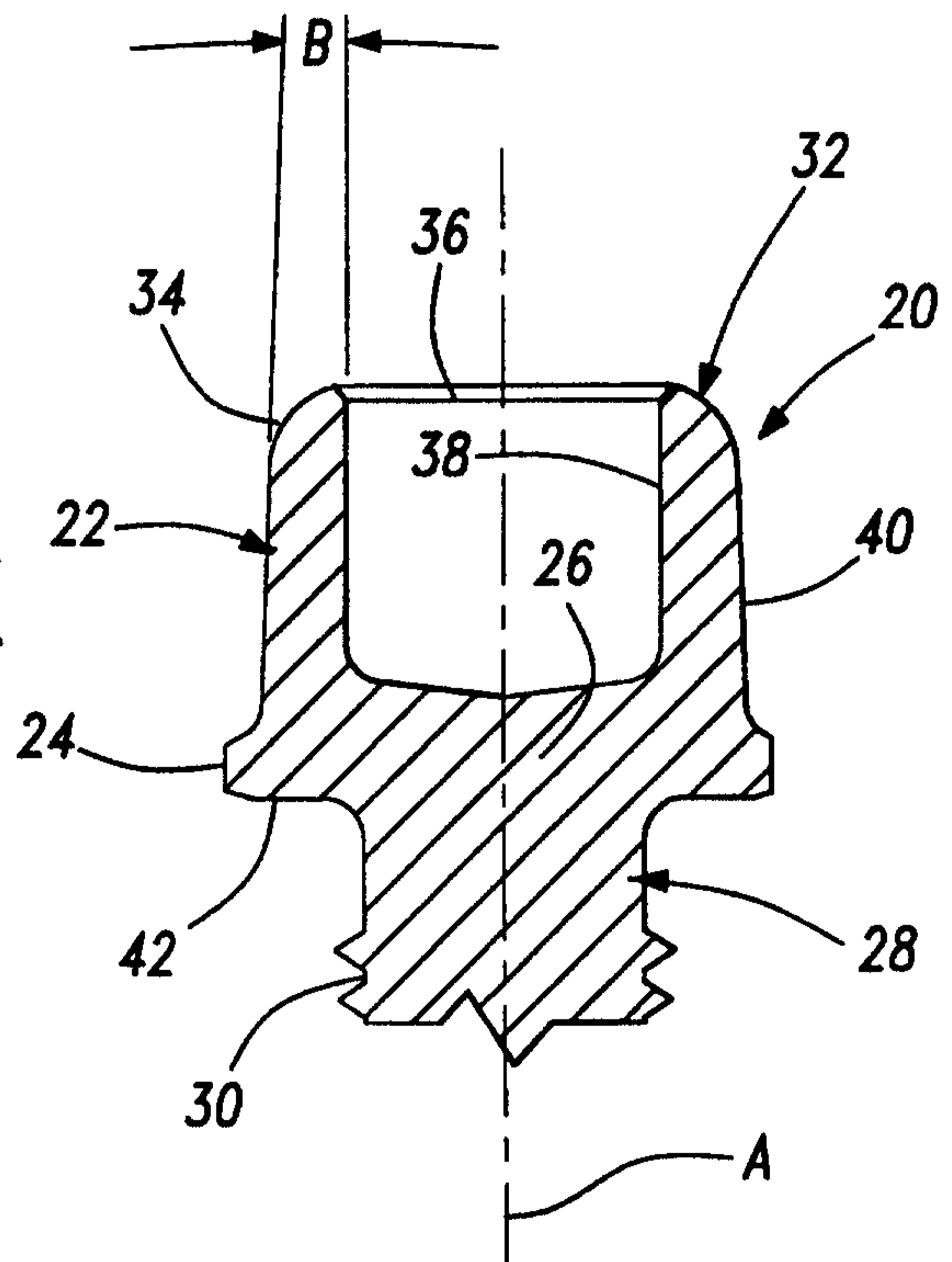
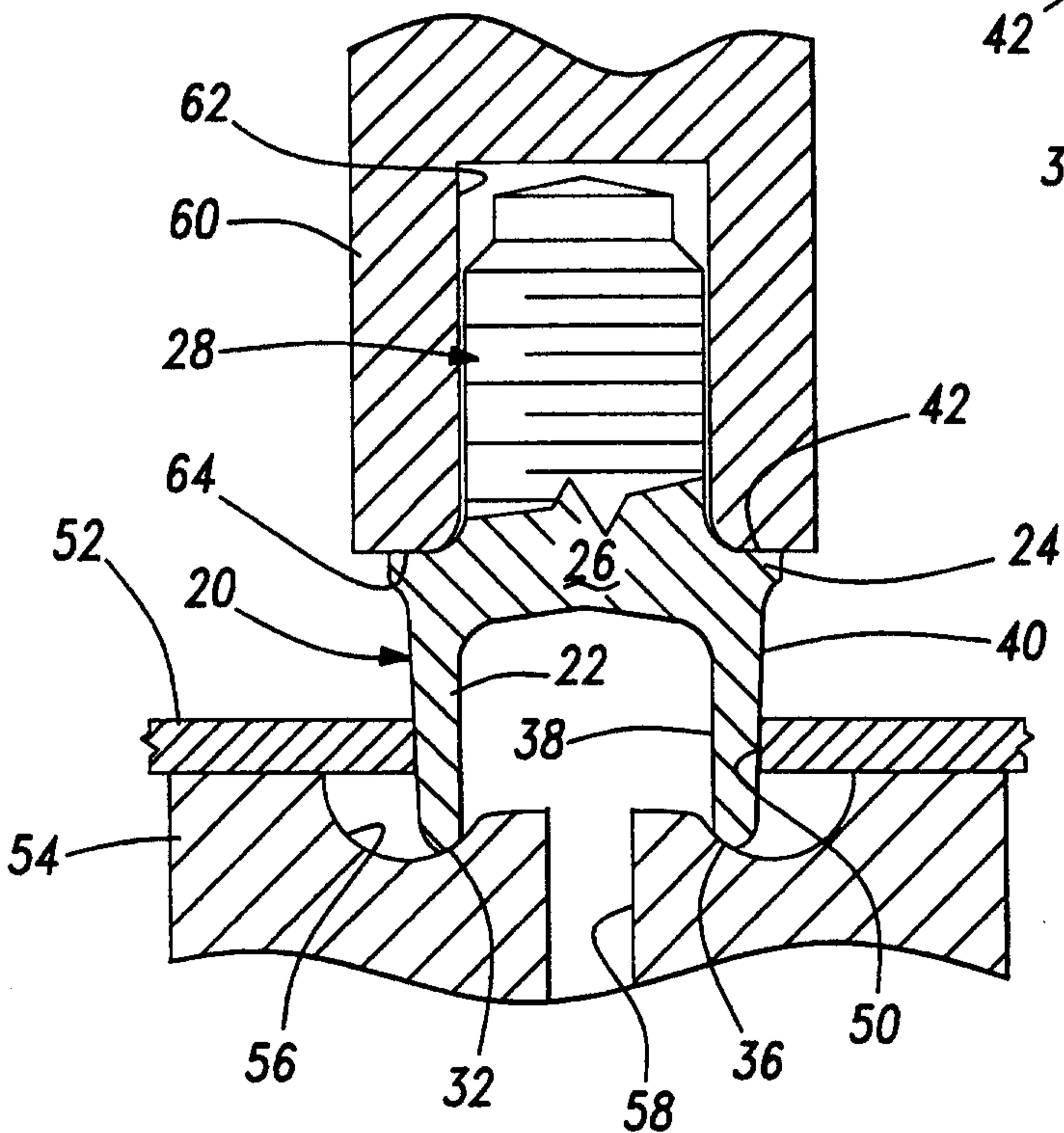

Fig-4



2/3

Fig-5

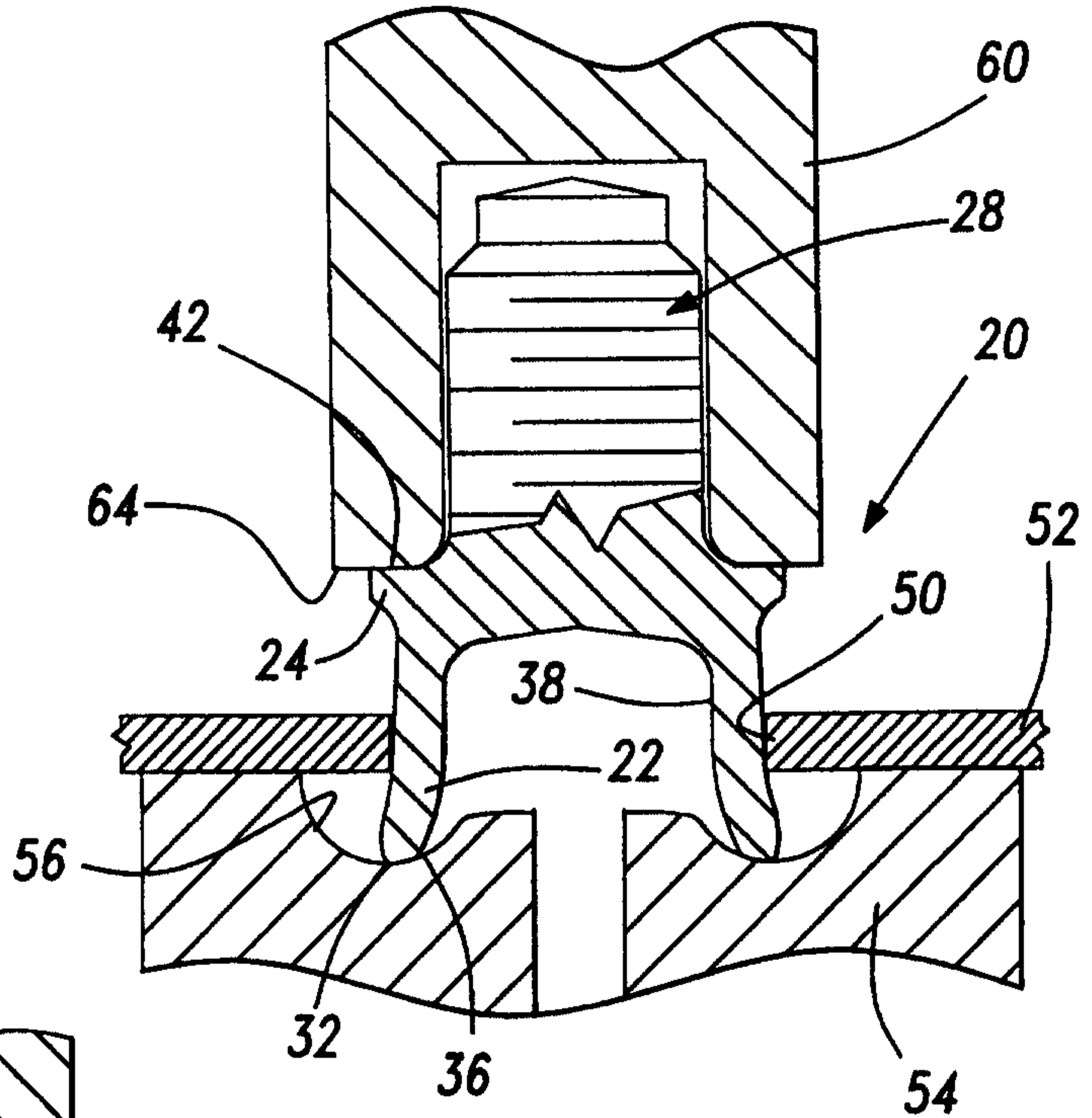

Fig-6

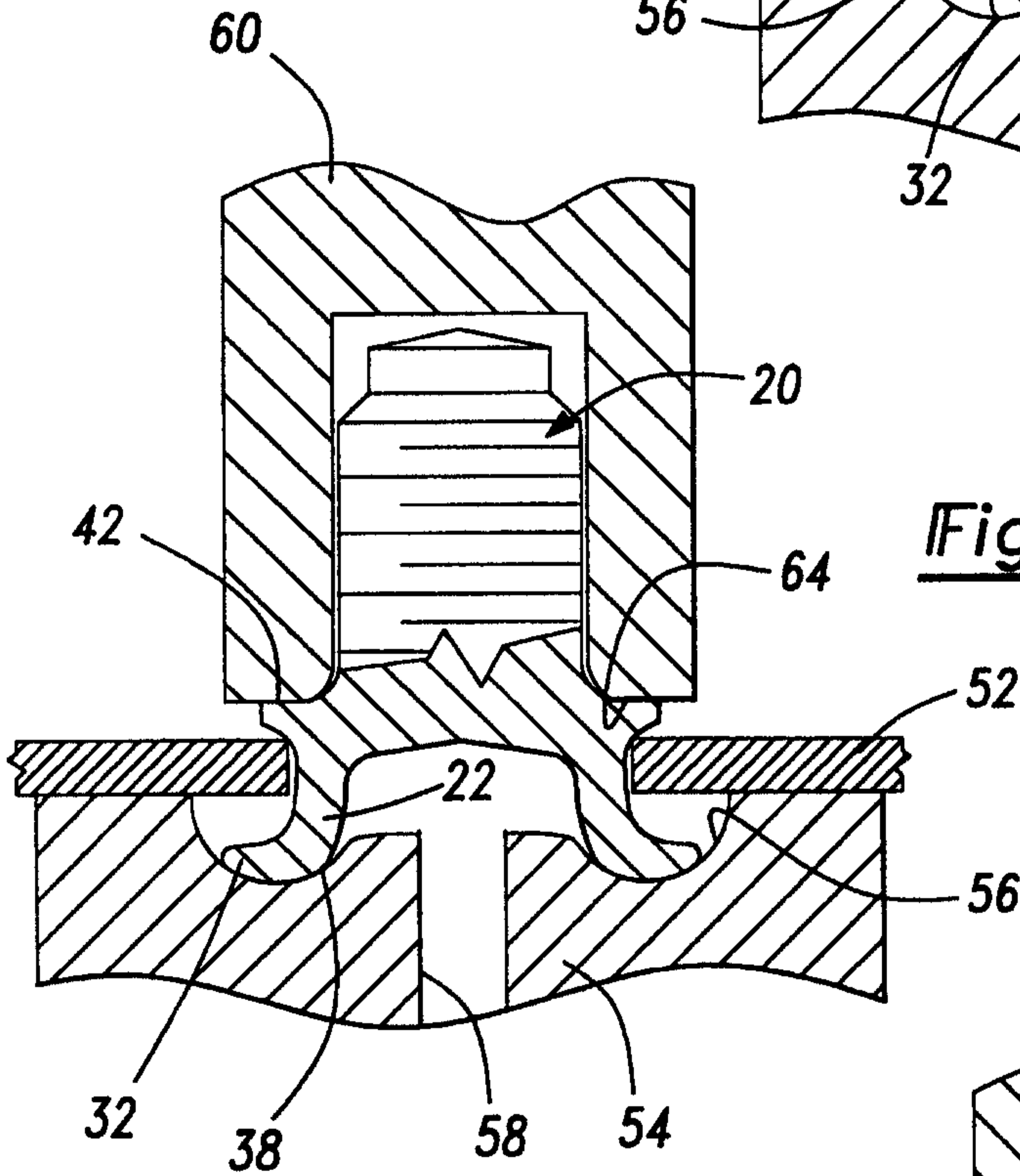
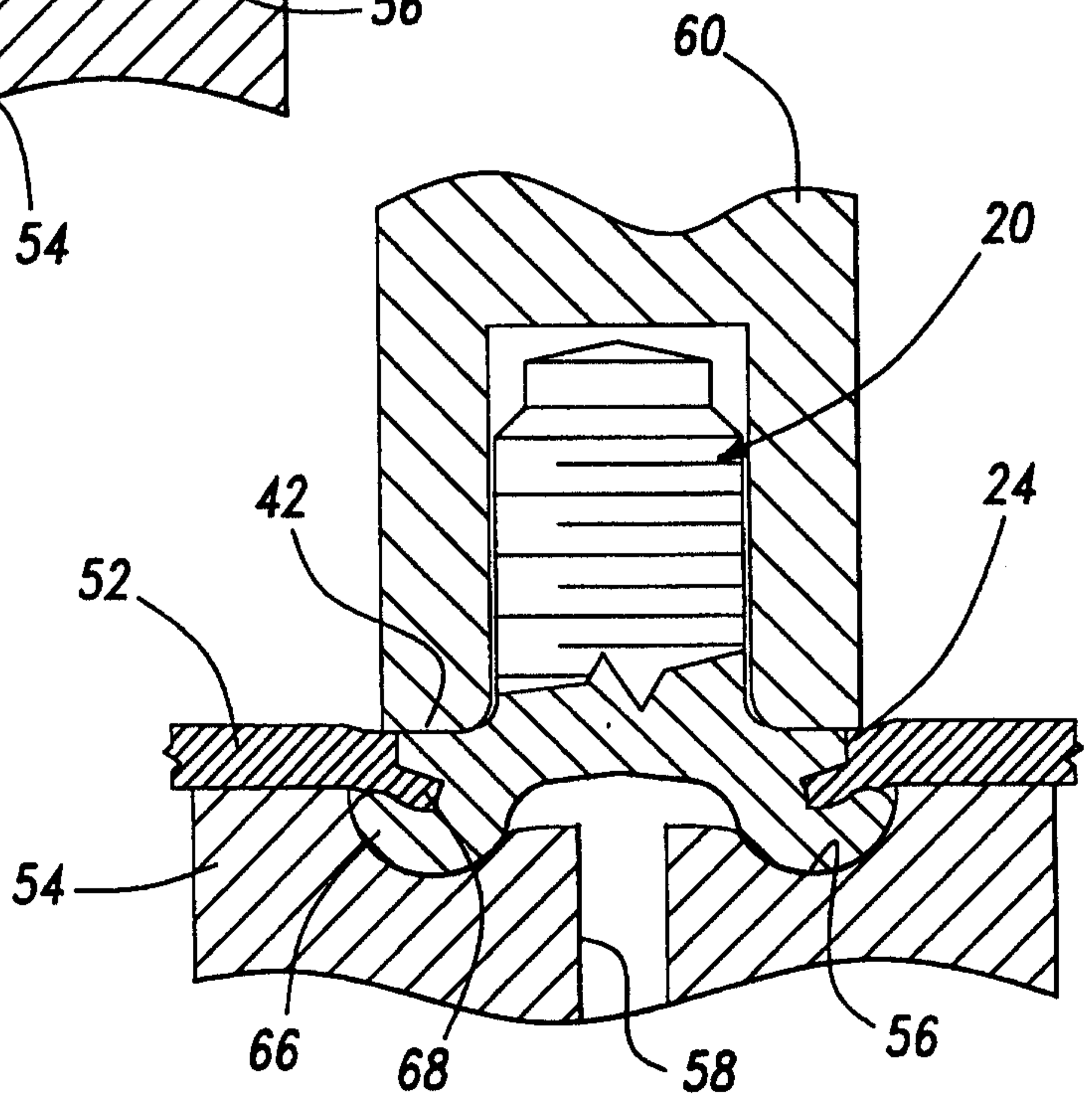

Fig-7



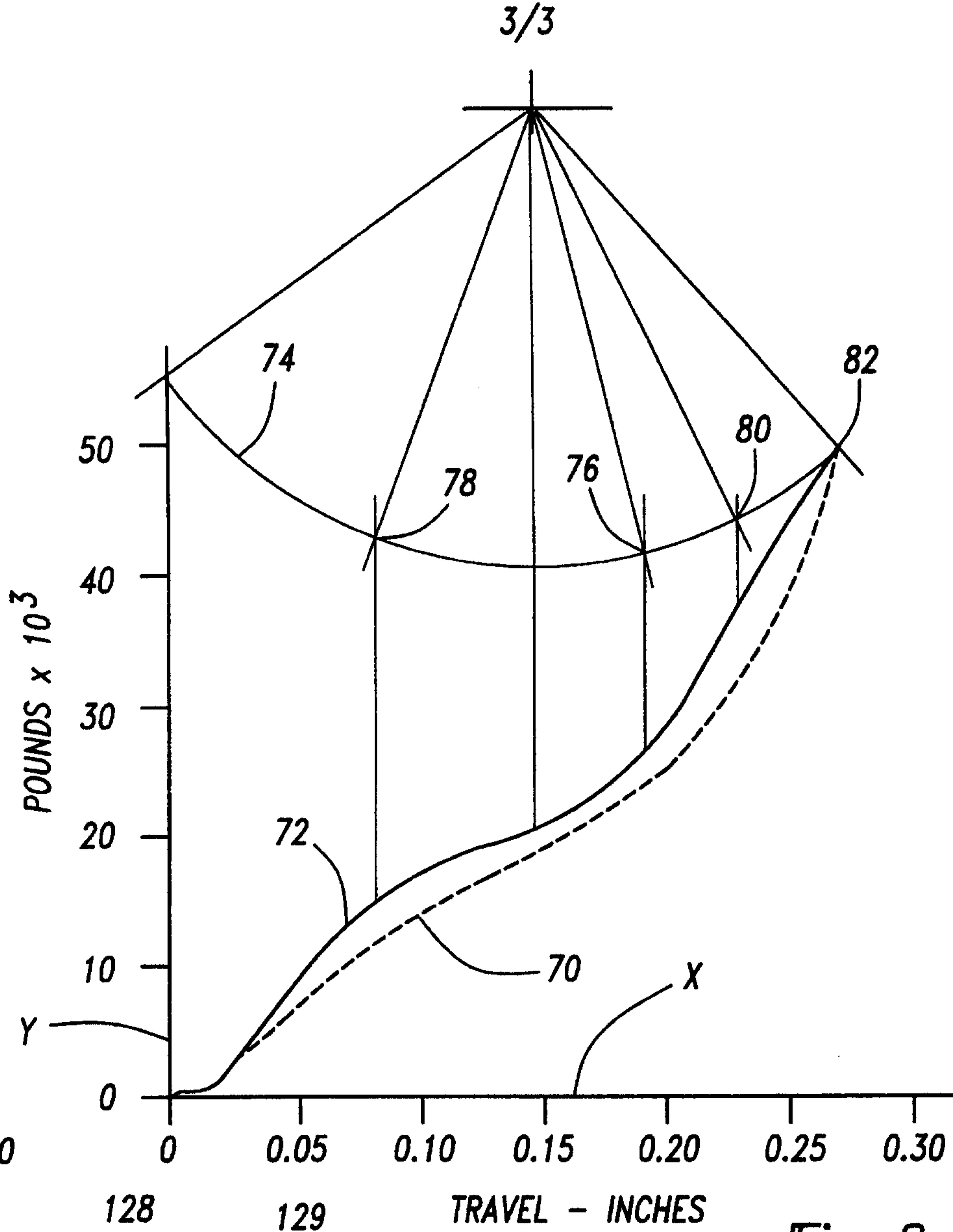

Fig-8

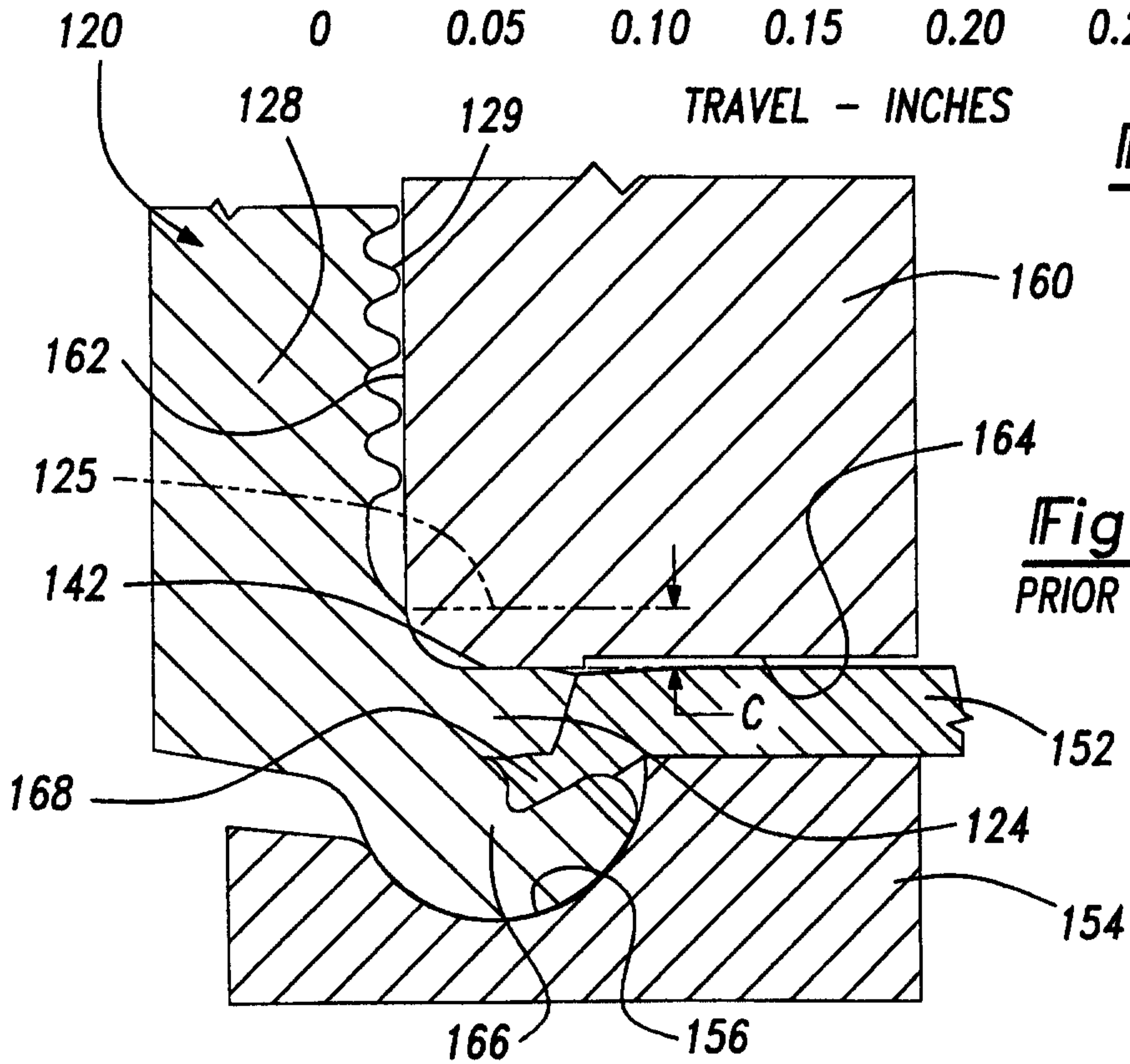

Fig-9
PRIOR FASTENER