

19



LE GOUVERNEMENT
DU GRAND-DUCHÉ DE LUXEMBOURG
Ministère de l'Économie

11

N° de publication :

LU100315

12

BREVET D'INVENTION

B1

21

N° de dépôt: LU100315

51

Int. Cl.:
G01F 11/00, A23G 1/20, A23G 3/02, A23G 3/20, G01F
11/02, B65B 37/06, B65B 37/20, B65B 3/32

22

Date de dépôt: 14/06/2017

30

Priorité:

72

Inventeur(s):
MARCARINO Massimiliano – 12051 Alba
(Cuneo) (Italie)

43

Date de mise à disposition du public: 18/12/2018

74

Mandataire(s):
OFFICE FREYLINGER S.A. –
8001 STRASSEN (Luxembourg)

47

Date de délivrance: 18/12/2018

73

Titulaire(s):
SOREMARTEC S.A. – 2632 Findel (Luxembourg)

54

Dropper Machine.

57

A dropper machine for pouring a measured amount of a substance in a plurality of receptacles (R), comprising: - a support structure (4), - a reservoir (6) containing the substance to be dropped, supported by said structure, - a plurality of cylinder (10) and piston (12) metering devices (8) with an inlet (18) positioned below the level of the substance to be dropped into the reservoir (6) and an outlet (10a) communicating with a respective dropper nozzle (16), - at least one drive unit (100A, 100B) arranged to simultaneously drive the piston of said metering devices (8) according to a forward and backward motion between a start position and an end position where the displacement of the pistons (12) from the end position to the start position causes the suction of the substance to be dropped from the reservoir (6) to the cylinder (10) of the metering devices and the displacement of the pistons (12) from the start position to the end position is adapted to cause the delivery of the substance to be dropped through the respective nozzles (16), characterized in that to each of said metering devices (8) is associated a respective actuating device (24) cooperating with the piston (12) of said metering device, said actuator device being operable individually to inhibit the delivery of the substance to be dropped through said nozzle (16) when the drive unit (100A, 100B) is actuated to cause displacement of the pistons of the metering devices associated therewith between the start position and the end position.

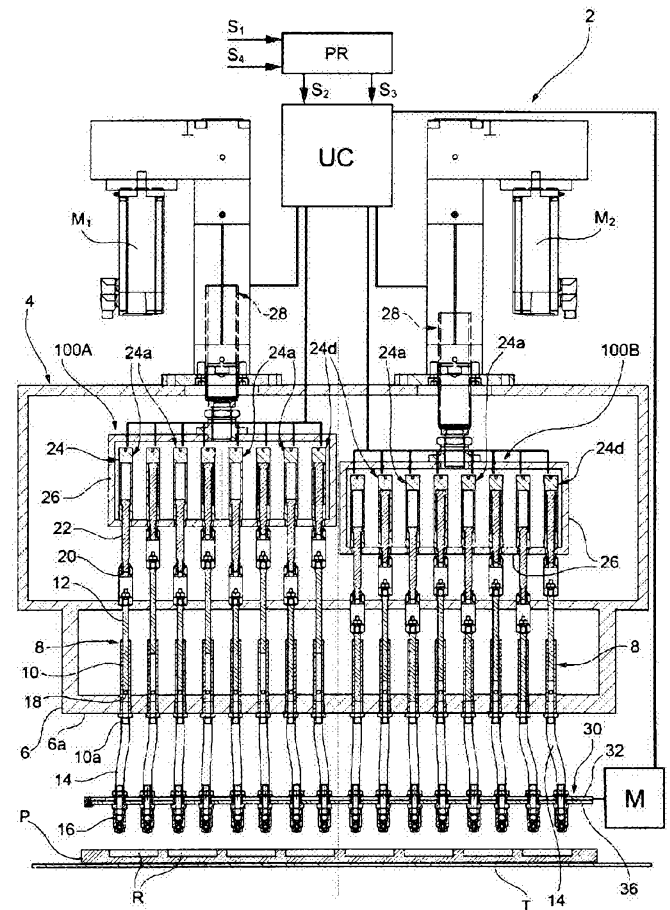

FIG. 1

Dropper machine

The present invention relates to a dropper or dosing machine and to a system comprising it, of the type used to deliver a measured amount of a substance in the fluid state into a receptacle (i.e. in a product in the process of formation).

Such dropper machines are widely used, particularly in the food industry, for various purposes, such as filling shells or valves of foodstuffs such as wafer or chocolate, the introduction of an inner filling in a bakery product or the like, or the filling of molds wherein the substance delivered in a fluid state is intended to solidify, forming a shaped product.

The term 'receptacle', used in this description, generally comprises food and non-food receptacles that are intended to receive, either in their interior or also on their outer surface, a measured quantity of the fluid substance mentioned above; however, the preferred embodiment of the invention and the one that draws greater advantages from the features of the dropper machine which is object of the invention is the one wherein the receptacles are shells or half-shells of foodstuffs obtained in a previous molding operation in the production line of a finished product wherein the dropper machine is inserted.

The term 'fluid' comprises substances or mixtures of flowable substances, such as liquids, including pasty or creamy liquids, regardless of their degree of viscosity; examples include lipid-based compositions (such as chocolate) and creamy compositions.

In general, a dropper machine of the aforementioned type comprises a support structure, a reservoir containing the material to be dropped, supported by said structure and a plurality of pump metering devices typically of a cylinder and piston type, generally arranged inside the reservoir, with an inlet positioned below the level of the fluid substance to be dropped and an outlet communicating with a respective dropper nozzle. The metering devices are simultaneously actuated by a drive group acting on the pistons of the metering devices, causing a forward and backward motion between two terminal positions, namely a start and end positions; the displacement of the piston from the end position to the start position causes the suction of the liquid to be metered from the reservoir to the cylinders of the metering

devices and the displacement of the pistons from the start position to the end position is adapted to cause the fluid to be metered to be delivered through the respective nozzles.

A dropper machine of this type is, for example, described in US 4,787,534.

The dropper machine is associated with a conveyor that sequentially conveys to the dropper machine the receptacles wherein the substance to be dropped is metered; in general, the conveyor is movable by steps with stop positions wherein the receptacles are aligned with the nozzles of the dropper machine, however, installations are also provided wherein the dropper machine is provided with a conveyor tracking motion so as to carry out the pouring in the absence of the relative motion.

In an industrial plant, the conveyor generally follows a predetermined path wherein a plurality of stations or devices are arranged, including the dropper machine, each of which may perform a particular operation for the production of a finished food product.

As has been said, in order to increase productivity, the substance is dropped into a plurality of receptacles generally housed in a plate or mold having cavities and arranged in a row transversely with respect to the conveyor's forward direction, or arranged in a matrix according to multiple rows and columns, and the dropper machine is equipped with a corresponding number of metering devices.

The object of the present invention is to provide an improved dropper machine which improves productivity by avoiding the production of defective finished products and/or by limiting or avoiding the stop times otherwise necessary to vary the spatial arrangement of the metering devices to suit the spatial arrangement, size, and nature of the receptacles when the dropper machine is used to prepare a different product.

In view of such object, the subject of the invention is a dropper machine having the features defined in the following claims, which form an integral and supplementary part of the present description.

In particular, the dropper machine object of the invention is able to avoid the production of defective products by inhibiting the delivery of the substance to be metered by one or more metering devices, the nozzles of which are arranged over a respective defective receptacle, for which the dropping of the substance would be an unnecessary waste. This feature is particularly important when the receptacles are made of wafer half-shells or similar baked goods or chocolate half-shells possibly produced on the same production line which includes the dropper machine, which may have surface defects, such as a mouth or opening with a crumbled rim that makes them unsuitable for continuing to the next stages of processing and wherein, therefore, dropping of the filling should be avoided.

In addition, the dropper machine allows the spatial arrangement of the nozzles of the active and inactive metering devices to be varied, in an automated way, thus allowing to quickly adapt the dropping configuration and the quantity of the product to be metered, without needing to stop the system, to different kinds of receptacles fed sequentially to the dropper machine.

Further advantages and features of the dropper machine according to the invention will become apparent from the detailed description that follows, made with reference to the accompanying drawings, provided by way of non-limiting example, wherein:

- figure 1 is a partially sectioned front view of a dropper machine according to the invention,
- figure 2 is a perspective view of a dropper machine according to figure 1, wherein, for illustrative simplicity, only a few construction parts are illustrated,
- figure 3 is a plan view of a cam device that allows the interaxial distance between the nozzles of the metering devices to be adjusted,
- figures 4 and 5 respectively illustrate a detail of the cam device in figure 3,
- figure 6 is a plan view of the cam device in figure 3 in its operative position,
- figure 7 is a schematic plan view showing the position of the active metering nozzles with respect to the receptacles in the operative position of figure 6,
- figure 8 is a plan view of the cam device in figure 3 in another operating position,
- figure 9 is a plan view showing the position of the active nozzles with respect to the receptacles wherein the dropping is carried out, in the operative position of figure 8,

and

- figure 10 is a schematic representation of a portion of a production line including the dropper machine that is object of the invention.

The example illustrated in the drawings refers to a dropper machine, indicated in its entirety at 2, operating on a production line for the industrial preparation of filled baked pastry products formed of two half-shells obtained by baking wafer batter or the like, coupled mouth-to-mouth and including a filling.

These half-shells are housed in corresponding seats of a dimpled plate P and fed by a conveyor T to the dropper machine 2. In subsequent processing stations, such half-shells, wherein the dropper machine has metered the food substance that constitutes the filling, are coupled, mouth-to-mouth to form the finished product.

The dropper machine 2 comprises a support structure 4 which is associated to a reservoir 6 for the substance to be poured, which is maintained in the fluid state.

The dropper machine comprises a plurality of metering devices 8 of the pump type comprising a cylinder 10 and a piston 12.

The cylinders 10 of each metering device, on a vertical axis, pass through the bottom wall 6a of the reservoir 6 and have an outlet opening 10a connected through a flexible duct 14 to a respective metering nozzle 16.

Each cylinder 10 has at least one inlet opening 18 which puts the inner cavity of the cylinder in communication with the fluid contained in the reservoir; such one or more openings are positioned in the cylinder at a level below the fluid level maintained in the reservoir.

Each piston 12 is connected by a coupling 20 to a rod 22 of an actuator device 24.

The actuators 24 are integral with a drive unit 100A (and 100B) comprising a framework 26 to which actuators 24, a motor M1 and a drive are fixed, in the described embodiment, said drive is a piston 28 and is connected to the framework 26. The motor M1, by means of the

piston 28, causes the vertical translation of the framework 26 and the actuators 24 connected thereto, according to a forward and return motion, causing the fluid substance to be metered to flow through the nozzles 16.

In particular, the drive unit, which causes the translation of the framework 26 and the actuators 24 integral to it, is arranged to simultaneously actuate the pistons 12 of all the metering devices 8 connected to the respective rod 22 of the actuators 24 according to a forward and return motion between a start position and an end position. The displacement of the pistons in the ascending motion from the end position (lowered) to the start position (raised) causes the suction of the fluid to be metered from the reservoir 6 to the inside of the respective cylinder 10 through the openings 18. Subsequently, the displacement of the pistons in descending motion, from the start position (raised) to the end position (lowered), is adapted to cause the delivery of the fluid to be metered through the respective nozzles. In particular, in the aforementioned descending motion, the piston 12, which is slidably sealed in the respective cylinder 10, covers in its travel the inlet openings 18, thus avoiding the return of the fluid substance in the reservoir and causing the expulsion of an amount of fluid substance to be metered through nozzle 16.

In the representation of figure 1, two drive units 100A and 100B are illustrated, each having associated thereto eight metering devices arranged in a row. It is understood that several rows of metering devices may be associated with each drive unit.

A first drive unit 100A, shown on the left side of figure 1, is illustrated in the start position (raised), from which the descending movement which is adapted to cause the expulsion of the fluid substance to be metered through the nozzles. A second drive unit 100B is illustrated on the right side of figure 1 at an end position, wherefrom the ascending motion subsequently starts causing the suction of the fluid substance to be metered inside the cylinders 10. The second drive unit, similar to the first one, comprises in turn a motor M2, a piston always indicated at the reference number 28, and a respective framework 26.

The dropper machine according to the invention allows the configuration of the drop to be varied to adapt such configuration to the arrangement of the receptacles R in the respective

support plate P, as well as to the shape features of the same receptacles.

This result is achieved by inhibiting the delivery of the fluid substance to be metered by one or more of the metering devices associated with a drive unit of the dropper. In particular, in the illustrated embodiment, such result is achieved by means of actuators 24 cooperating with the piston 12 of the respective metering device and which are adapted to be individually actuated to prevent the delivery of the fluid substance to be metered through the respective nozzle when the drive unit is actuated to cause the delivery, otherwise simultaneous, from all the measuring devices.

Actuators 24 may for example be pneumatic or electric actuators and each of them is electrically connected to a control unit UC which enables them to be activated or deactivated individually.

In the illustrated embodiment, the disabling of the delivery by a single metering device 8 is achieved by means of a command which sets the axial displacement of the rod 22 of the actuator 24 to a raised position; in this deactivation position, the axial displacement of the piston 12 connected to the rod 22 from the raised start position to the lowered end position caused by the drive unit, causes the ejection of the fluid substance to be delivered, contained in the cylinder 10, through the openings 18 inside the reservoir, since in its downward stroke the piston does not cover such openings.

The delivery is activated by moving the actuator rod 22 to the lowered position (extended); in this position of activation, the axial displacement of the piston 12 connected to the rod 22, from the raised start position to the lowered end position caused by the drive unit, causes the ejection of the fluid substance to be delivered through the nozzles 16, since in its downward travel the piston covers the openings 18.

In figure 1 at 24a are indicated some of the actuators which are in position to activate the delivery and wherein the rod 22 is consequently in a lowered position; at 24d are indicated some of the actuators in the deactivated position wherein the respective rod 22 is in the raised position.

In order to prevent the outflow by gravity of the fluid substance to be dropped contained in the ducts 14, when the delivery device is deactivated or in the suction step of said fluid within the respective cylinder, the nozzles 16 preferably have an obturator, for example of the ball type, with elastic contrast means, which keeps the nozzle in the closed position during such steps and allows the delivery when the pressure exerted by the pistons 12 overcomes the opposing force exerted by the elastic means on the ball.

In a preferred embodiment, the dropper machine according to the invention furthermore allows the spatial arrangement of the nozzles to vary according to a plurality of predefined configurations, in an automated way and without the need to stop the machine to change the positioning of the metering devices in the support structure wherein they are mounted.

To this end, the dropper machine comprises a cam device, indicated in its entirety at 30, the features of which are further illustrated in figures 3 to 5. This device comprises a plate 32 having a plurality of cams constituted by slits 34 (figure 3), passing through the plate, which extend according to a predetermined path, and a second plate 36 having at least one rectilinear and transverse slit 38 (figure 3). The plates 32 and 36 are fastened to each other by means of one or more pins 40 (figures 3 and 4) that slidably engage one or more rectilinear slits 42; the plates 32 and 36 are therefore adapted to translate relative to each other in a direction orthogonal to the slit 38 by means of a drive, e.g., a motor M (figure 1) the activation of which is controlled by a control unit UC.

The nozzles 16 are in communication with the respective cylinder 10 by means of a flexible duct 14, which allows the variation of the interaxial distance between the nozzles. Each nozzle engages the slit 38 and a respective slit 34 and is vertically bound to the same. The translation of one plate with respect to the other, in the horizontal plane, in the direction of the arrow F (figure 3), i.e. in a direction orthogonal to the extension of the slit 38, therefore, causes a corresponding translation of the nozzles 16, bound to follow the path of a respective slit 34, causing a change in the interaxial distance between the nozzles in the transverse direction and therefore the change of their delivery point with respect to the receptacles R, as a function of the path of the slits 34.

Figure 6 illustrates an operative position of the cam device wherein the position of the nozzles 16 is visible with respect to the receptacles R which are illustrated with a dotted line as they are fed by the dropper machine in the position underlying the cam device, possibly housed in the cavities of a dimpled plate P (see figure 1). In figure 6, the nozzles 16 are arranged at one end of the respective slit 34. The translation of the plate 32 in the direction and way of the arrow F (or vice versa of the plate 36 in the opposite direction) results in a change in the distance between the nozzles 16 as a function of the path of the slits 34. It is possible to provide that the plate 32 (or the plate 36) may be moved by the motor M to any position along the course of the slits 34 or alternatively, that the motor M makes possible a predetermined number of relative positions; figure 8 shows, for example, with reference to each nozzle 16, four positions, P1, P2, P3, and P4, represented with a dotted circle along the course of a slit 34.

The course of the slits 34 is predetermined as a function of the arrangement of the desired dropping points in relation to the receptacles R. For example, in the position illustrated in figure 8, two nozzles 16c and 16b are provided to carry out the delivery of the substance to be dropped into a single receptacle R.

One may appreciate the fact that the dropper machine according to the invention allows the operator to vary the delivery configuration as a function of the arrangement and nature of the receptacles fed to the dropper machine by using the cam device 30 in combination with the activation or deactivation of the metering devices 8 generated by actuators 24. Thus, in order to obtain a predetermined configuration of the arrangement of the nozzles, it is possible to operate the cam device 30 and jointly proceed with the activation/deactivation of one or more metering devices. This possibility is illustrated, for example, in figure 6 where 16a indicates nozzles of which the metering device is activated and 16d indicates nozzles of which the metering device is deactivated; the corresponding delivery configuration is illustrated in figure 7 wherein is shown the arrangement of the receptacles R, to which an active nozzle 16a corresponds.

Similarly, figure 9 illustrates the arrangement of the receptacles R wherein the nozzles 16c

and 16b, both active, deliver the substance to be metered; in this case, two nozzles deliver the substance into a single receptacle.

Figure 2 is a perspective view illustrating a portion of the dropper machine of figure 1 showing a single measuring device 8 of which the nozzle engages the cam device 32; in figure 2, elements corresponding to the elements illustrated in figure 1 are indicated with the same reference number.

A first advantage of the dropper machine according to the invention lies in the possibility of avoiding waste of the fluid substance to be metered by inhibiting the delivery when one or more of the receptacles R is defective and therefore unfit to receive the fluid substance.

Another advantage consists in the possibility of varying the configuration of the delivery when the dropper machine is used in the same production line to pour the substance into receptacles R of various kinds and dimensions that are fed to the dropper machine on support plates with different dimensional and spatial configurations, thus requiring a variation in the arrangement of the nozzles.

To this end, the dropper machine or the production line wherein the dropper machine is inserted may comprise, upstream from the dropper machine or at its inlet, a read device 50 or 52 (figure 10) arranged to generate a signal that allows:

- i) identification of any receptacles which are defective or non-compliant with production specifications,
- ii) determination of the location of said defective receptacles, in the support plate wherein they are housed, and/or
- iii) determination of the parameters relating to the receptacles into which the fluid substance is to be delivered and their arrangement on the support plate, i.e. the parameters on which the spatial configuration of the dropper nozzles depends in relation to the product that one wishes to obtain.

In one embodiment, said aforementioned read device may be a sensor or preferably a display and/or image recording device comprising, for example, a camcorder 54. Such read device is

arranged to generate a signal S1 that may be processed by a computer device, such as a processor PR (figure 10), which in turn sends the control unit UC associated with the dropper machine a signal S2 identifying the parameters referred to in points i), ii) and/or iii). It is understood that for the identification of defective receptacles, the processor PR can perform such operation by comparing the signal S1 with predetermined and saved reference data concerning non-defective receptacles.

Alternatively, or at the same time, the read device may be an electronic unit 52 arranged to receive an identifying signal of the parameters and characteristics of the receptacles wherein the fluid substance must be metered and of their placement on the related support plate P, to which corresponds a predetermined spatial configuration of the nozzles.

In this embodiment, each support plate P has an identifying device indicated at I in figure 10. Such device may be, for example, a so-called RFID, including integrated electronic memory devices wherein information or data are readable and writable, without contact, by means of an associated antenna or the like. In such memory devices of the identification device I are stored distinctive information or data on the nature of the support plate P, the related arrangement of the supporting cells, the receptacles and/or the nature of the receptacles themselves. In other embodiments, the identification device I may be a barcode or a QR code.

The S4 read signal of the identification device, possibly processed by the processor PR to generate a signal S3, is then fed to the control unit UC of the dropper machine. It is understood that the electronic unit 52 and its related processor may constitute part of the dropper machine 2.

According to the aforementioned signals (S2 and/or S3), the control unit UC is arranged to:

- generate an individual activation signal for the individual actuators 24, independently from each other, to bring the delivery device 8 associated to them into the activation and/or deactivation position when the read device detects the presence of a receptacle that does not conform to the specifications and/or when it detects the feeding of receptacles to the dropper machine that require a different dropping configuration;
- generate an activation signal of the motor M associated with the cam device 30 to vary the interaxial distance between the nozzles 16 and consequently the delivery

configuration when conditions corresponding or analogous to the aforesaid conditions occur;

- actuate the pistons 28 via the motor M1 and/or M2 to determine the suction and compression cycle and subsequent delivery by all the metering devices 8 associated with the same drive unit.

By these features, the invention provides a highly flexible and selective dropper machine, allowing a wide variety of delivery configurations without the need to stop the production cycle.

With this, the flexibility of production may be greatly increased.

Naturally, without altering the principle of the invention, the embodiments and the details of the embodiment may vary widely with respect to those described and illustrated purely by way of non-limiting example, without thereby departing from the scope of the invention as defined in the following appended claims.

REVENDICATIONS

1. Machine de dépôt au compte-gouttes pour déposer au compte-gouttes une quantité mesurée d'une substance dans une pluralité de réceptacles (R),
5 comprenant :
- une structure de support (4),
 - un réservoir (6) contenant la substance à déposer au compte-gouttes, supporté par ladite structure,
 - une pluralité de dispositifs de mesure (8) de type à cylindre (10) et à
10 piston (12) dotés d'un orifice d'entrée (18) positionné sous le niveau de la substance à verser dans le réservoir (6) et d'un orifice de sortie (10a) communiquant avec une buse de dépôt au compte-gouttes respective (16),
 - au moins une unité d'entraînement (100A, 100B) agencée pour entraîner simultanément les pistons desdits dispositifs de mesure (8) selon un
15 mouvement en avant et en arrière entre une position de départ et une position de fin, le déplacement des pistons (12) depuis la position de fin vers la position de départ entraînant l'aspiration de la substance à déposer au compte-gouttes depuis le réservoir (6) vers le cylindre (10) des dispositifs de mesure et le déplacement des pistons (12) depuis la position de départ vers la position de fin étant adapté à
20 provoquer la distribution de la substance à déposer au compte-gouttes à travers les buses respectives (16), caractérisée en ce que, à chacun desdits dispositifs de mesure (8), est associé un dispositif d'actionnement respectif (24) coopérant avec le piston (12) dudit dispositif de mesure, ledit dispositif d'actionnement étant opérable individuellement pour empêcher la distribution de la substance à
25 déposer au compte-gouttes à travers ladite buse (16) quand l'unité d'entraînement (100A, 100B) est actionnée pour provoquer le déplacement des pistons des dispositifs de mesure qui leur sont associés entre la position de départ et la position de fin.

BL-5037

2. Machine de dépôt au compte-gouttes selon la revendication 1, caractérisée en ce que ledit dispositif d'actionnement (24) est adapté à provoquer le déplacement du piston (12) du dispositif de mesure respectif (8) entre une position de désactivation de la distribution et une position d'activation de la distribution à travers la buse respective, où, dans ladite position de désactivation, le déplacement axial du piston de la position de départ vers la position de fin, provoqué par l'unité d'entraînement (100A, 100B), entraîne l'expulsion de la substance à déposer au compte-gouttes contenue dans ledit cylindre à travers ladite ouverture d'entrée (18) à l'intérieur du réservoir (6), alors que dans ladite position d'activation de dépôt au compte-gouttes, ledit déplacement axial du piston depuis la position de départ vers la position de fin, provoqué par l'unité d'entraînement, provoque le dosage de la substance à mesurer à travers ladite buse (16).

3. Machine de dépôt au compte-gouttes selon la revendication 2, caractérisée en ce que ledit dispositif d'actionnement (24) comprend une tige (22) connectée au piston (12) du dispositif de mesure, ladite tige étant axialement mobile entre une première et une seconde position correspondant auxdites positions d'activation et de désactivation de la distribution du piston (12).

4. Machine de dépôt au compte-gouttes selon l'une quelconque des revendications 1 à 3, caractérisée en ce que chacune desdites buses (16) est connectée au cylindre du dispositif de mesure respectif (8) au moyen d'un tuyau (14) qui permet la variation de la distance inter-axiale entre les buses et dans laquelle lesdites buses (16) s'engagent avec les cames d'un dispositif à cames (30) fonctionnant dans une pluralité de positions de fonctionnement pour provoquer la variation de la distance inter-axiale entre les buses.

5. Machine de dépôt au compte-gouttes selon la revendication 4, caractérisée en ce que ledit dispositif à cames (30) comprend des première (32) et deuxième

BL-5037

(36) plaques superposées, connectées l'une à l'autre de manière coulissante, où ladite deuxième plaque (36) comportant une fente rectiligne (38) qui s'étend selon une direction orthogonale à la direction de coulissement et la première desdites plaques (32) comportant une pluralité de cames sous l'apparence de fentes (34) s'étendant selon un chemin prédéterminé selon une direction généralement parallèle à la direction de coulissement, où chacune desdites buses (16) s'étend à travers ladite fente rectiligne (38) et à travers une fente respective (34) de ladite pluralité de fentes de la première plaque, étant verticalement liée à celle-ci, moyennant quoi le coulissement d'une plaque par rapport à l'autre entraîne la variation de la distance inter-axiale entre les buses.

6. Machine de dépôt au compte-gouttes selon la revendication 5, caractérisée en ce que ledit dispositif à cames (30) est actionné au moyen d'un dispositif d'actionnement (M), ce qui permet le positionnement desdites première (32) et deuxième (36) plaques l'une par rapport à l'autre dans une pluralité de positions de fonctionnement.

7. Machine de dépôt au compte-gouttes selon l'une quelconque des revendications précédentes, caractérisée en ce qu'elle comprend au moins un dispositif de lecture (50, 52) adapté à générer un signal qui permet :

- i) l'identification de tout réceptacle défectueux ou de tout réceptacle ne se conformant pas aux spécifications de production,
- ii) la détermination de l'emplacement des réceptacles défectueux précités, dans la plaque de support (P) dans laquelle ils sont logés, et/ou
- iii) la détermination des paramètres se rapportant aux réceptacles dans lesquels la substance doit être déposée au compte-gouttes et/ou à leur agencement dans la plaque de support, dont dépend la configuration spatiale des buses de dépôt au compte-gouttes (16) en fonction du produit que l'on souhaite obtenir.

BL-5037

8. Machine de dépôt au compte-gouttes selon la revendication 7, caractérisée en ce que ledit dispositif de lecture (50) est un dispositif d'affichage et/ou un dispositif d'enregistrement d'image tel qu'un dispositif de visualisation (54).

5 9. Machine de dépôt au compte-gouttes selon la revendication 7, caractérisée en ce que ledit dispositif de lecture (52) comprend une unité électronique agencée pour recevoir un signal identifiant les paramètres et caractéristiques des réceptacles (R) dans lesquels la substance fluide doit être mesurée et de leur emplacement dans la plaque de support associée (P).

10

10. Machine de dépôt au compte-gouttes selon la revendication 9, caractérisée en ce que chaque plaque de support (P) comprend un dispositif d'identification (I) associé tel qu'un RFID, un code-barres ou un code QR.

15 11. Machine de dépôt au compte-gouttes selon la revendication 10, caractérisée en ce que ledit dispositif d'identification (I) est un RFID incluant des dispositifs de mémoire intégrée dans lesquels des informations ou données peuvent être lues et/ou écrites, sans contact, au moyen d'une antenne associée ou similaire.

20

12. Machine de dépôt au compte-gouttes selon l'une quelconque des revendications 7 à 11, caractérisée en ce qu'elle comprend une unité de commande (UC) adaptée à générer un signal d'activation individuel pour les dispositifs d'actionnement individuels (24), indépendamment les uns des autres, afin d'amener le dispositif de mesure (8) qui leur est associé dans la position d'activation et/ou de désactivation quand ledit dispositif de lecture détecte la présence d'un réceptacle qui n'est pas conforme aux spécifications et/ou quand il détecte l'acheminement de réceptacles à la machine de dépôt au compte-gouttes qui nécessitent une configuration de compte-gouttes différente.

30

BL-5037

13. Machine de dépôt au compte-gouttes selon l'une quelconque des revendications 7 à 12, caractérisée en ce qu'elle comprend une unité de commande (UC) agencée pour générer un signal d'activation du dispositif d'actionnement (M) associé audit dispositif à cames (30) afin de faire varier la distance inter-axiale entre les buses (16) et en conséquence la configuration de distribution quand ledit dispositif de lecture détecte l'acheminement à la machine de dépôt au compte-gouttes de réceptacles qui nécessitent une configuration de dépôt au compte-gouttes différente.

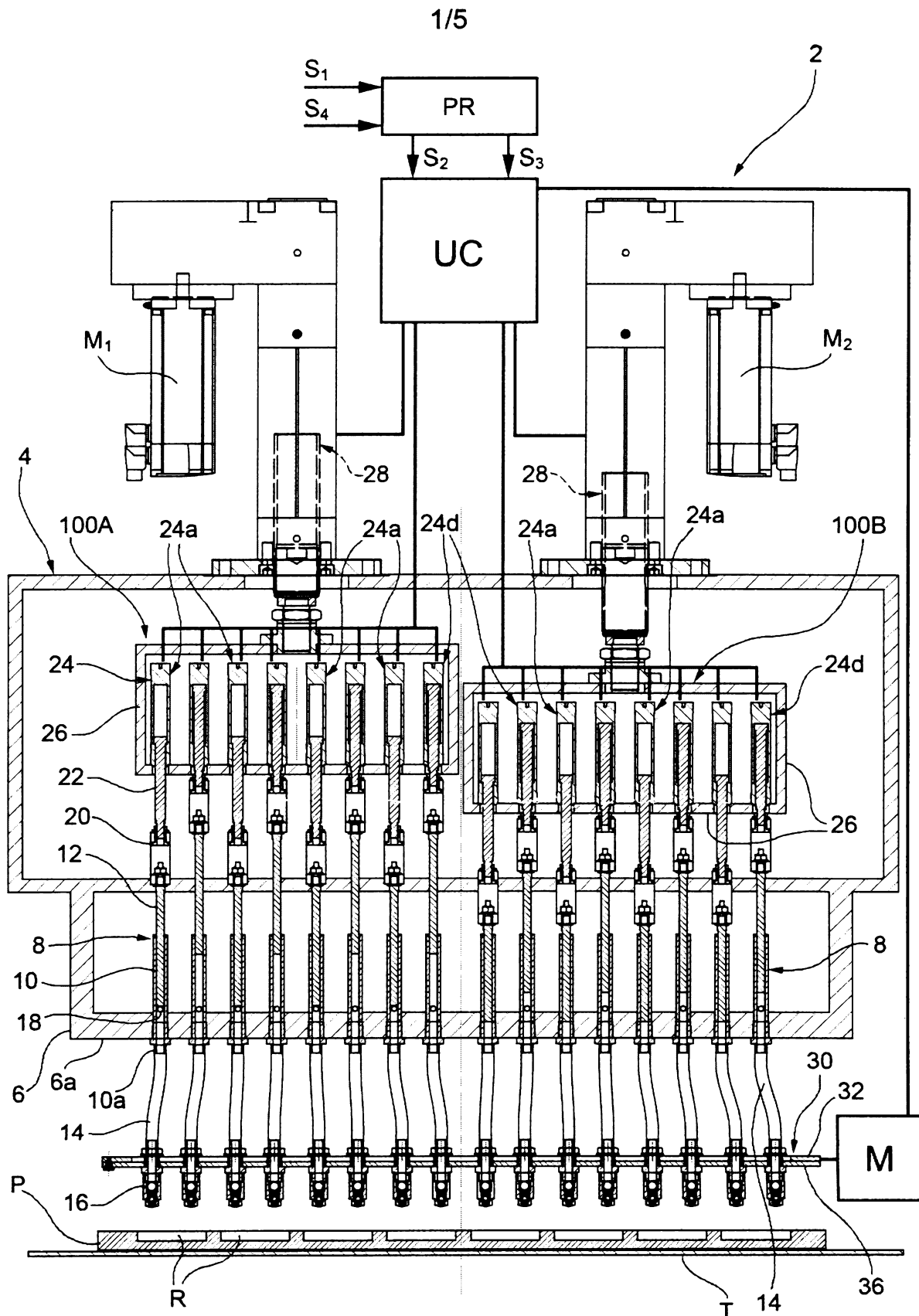

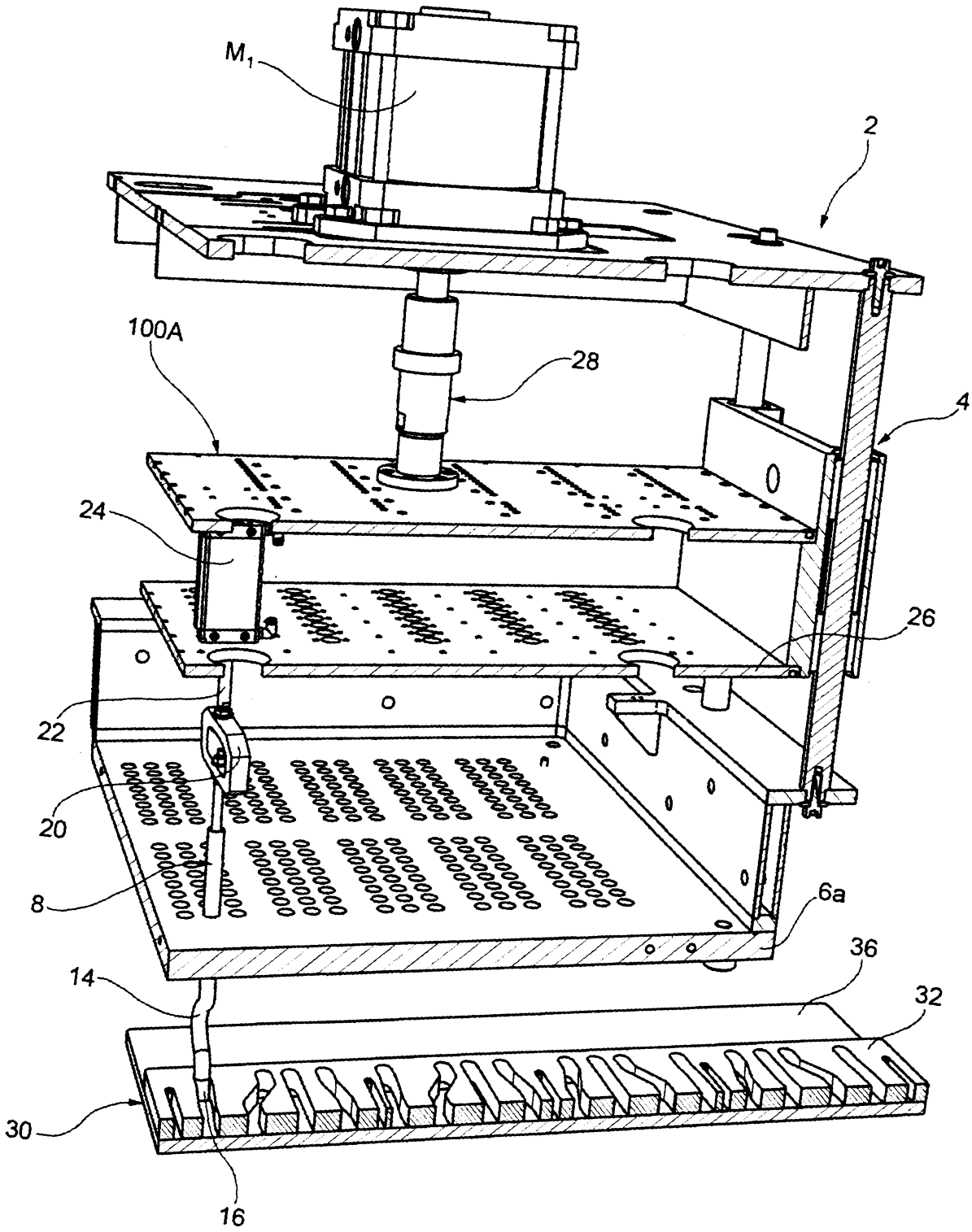

FIG. 2

3/5

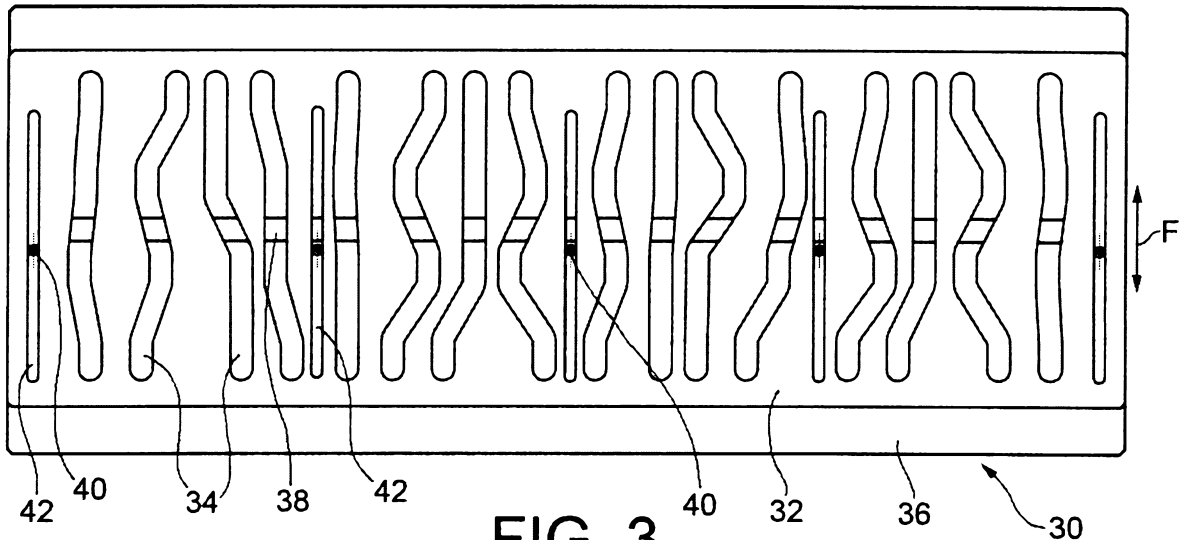

FIG. 3

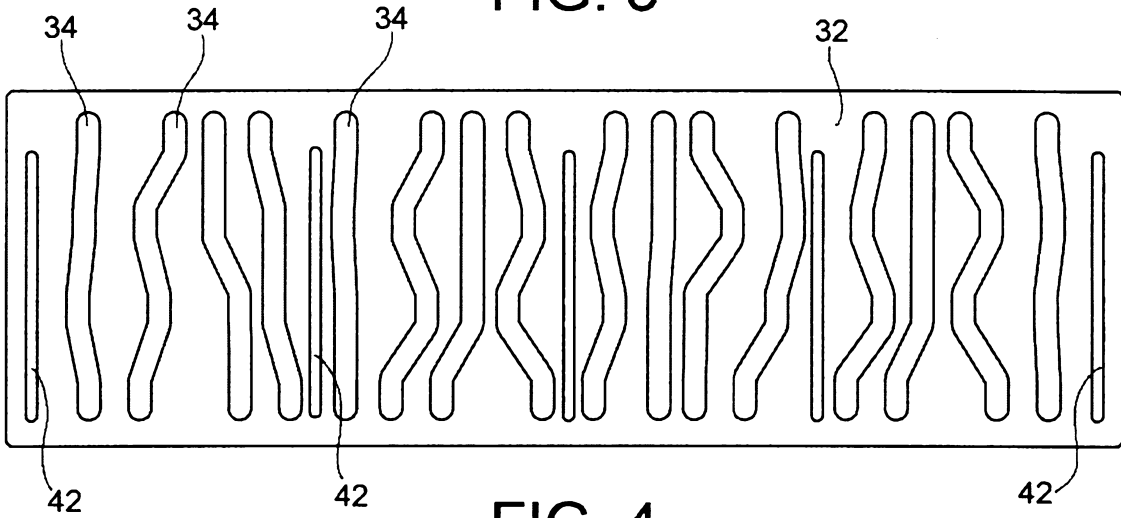

FIG. 4

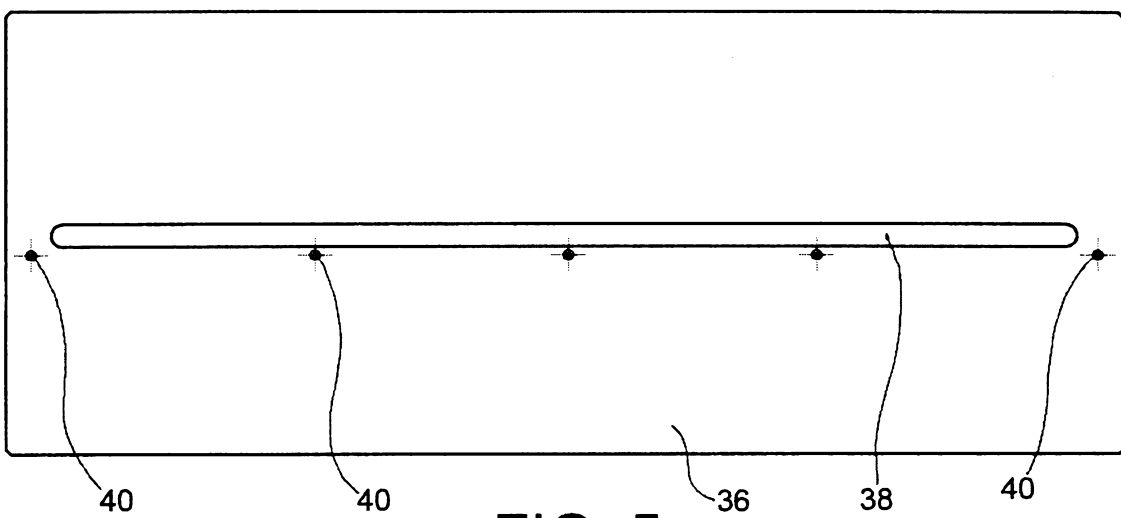

FIG. 5

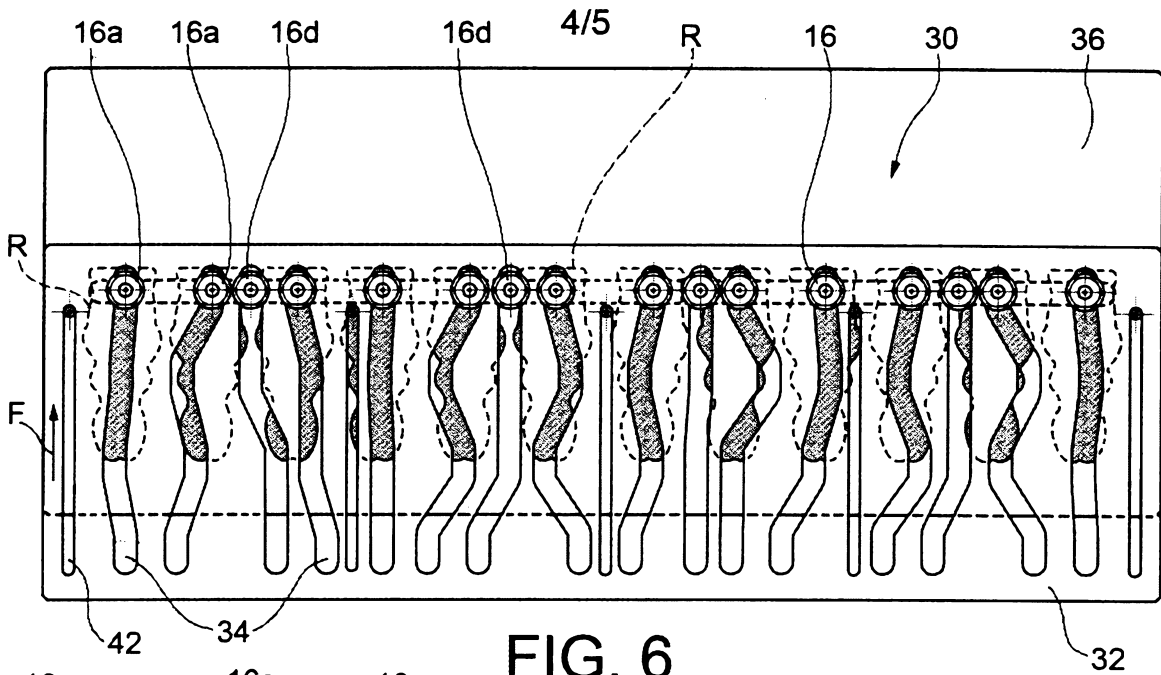

FIG. 6

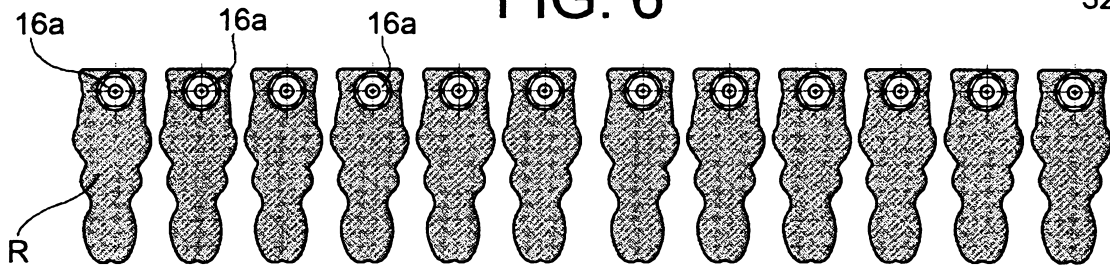

FIG. 7

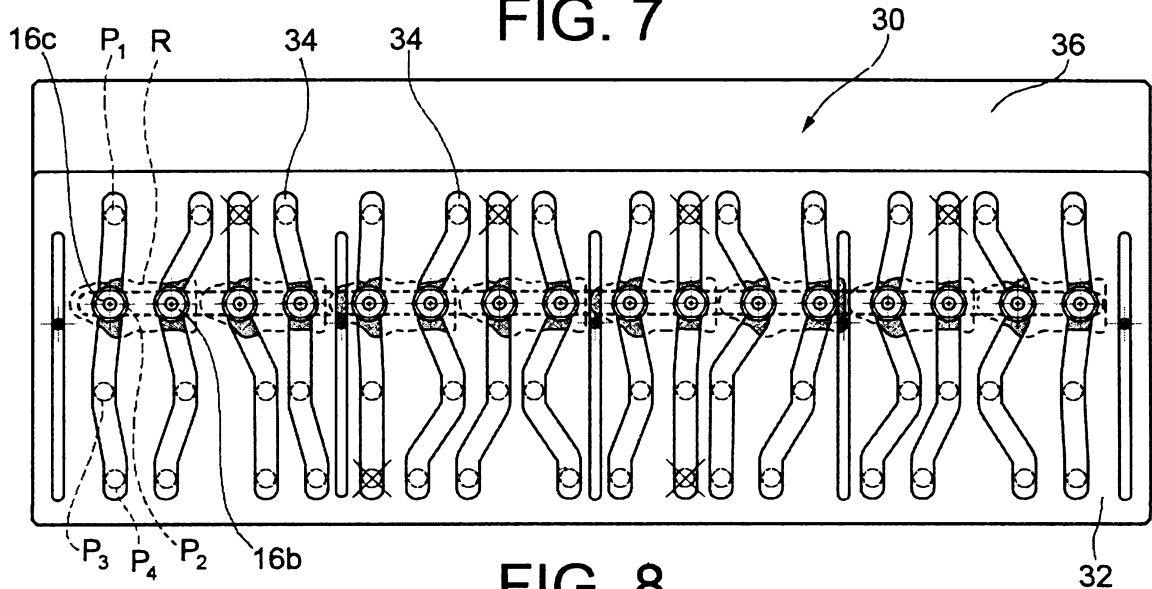

FIG. 8

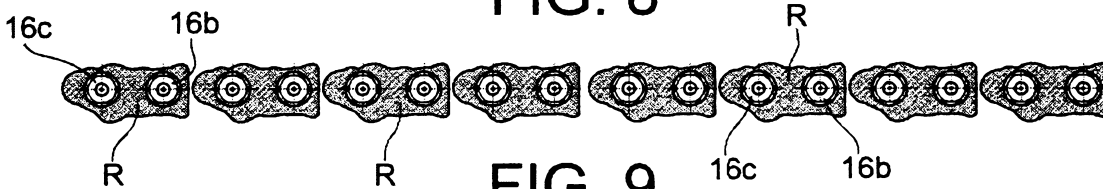

FIG. 9

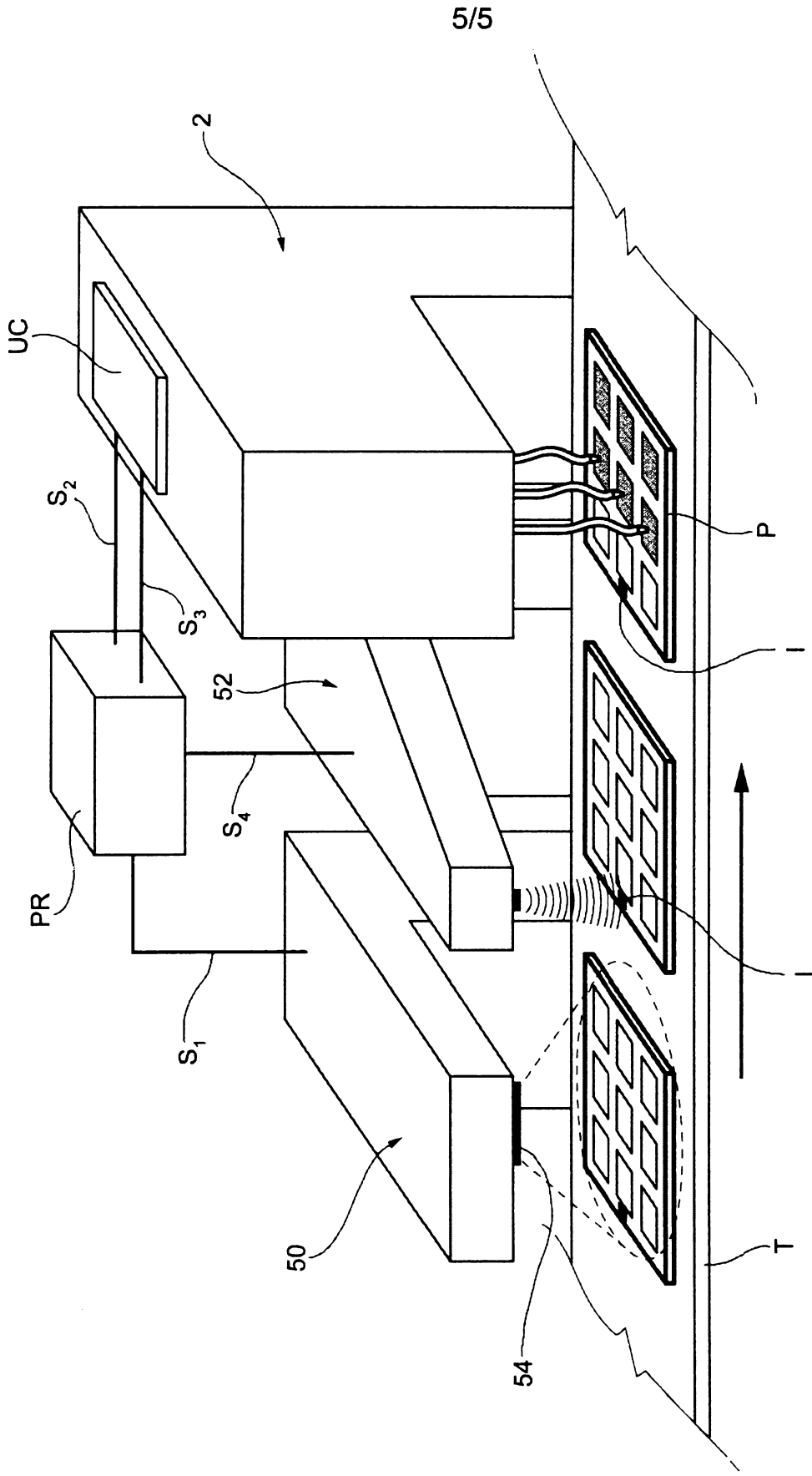

FIG. 10

ABSTRACTDropper machine

A dropper machine for pouring a measured amount of a substance in a plurality of receptacles (R), comprising:

- a support structure (4),
- a reservoir (6) containing the substance to be dropped, supported by said structure,
- a plurality of cylinder (10) and piston (12) metering devices (8) with an inlet (18) positioned below the level of the substance to be dropped into the reservoir (6) and an outlet (10a) communicating with a respective dropper nozzle (16),
- at least one drive unit (100A, 100B) arranged to simultaneously drive the piston of said metering devices (8) according to a forward and backward motion between a start position and an end position where the displacement of the pistons (12) from the end position to the start position causes the suction of the substance to be dropped from the reservoir (6) to the cylinder (10) of the metering devices and the displacement of the pistons (12) from the start position to the end position is adapted to cause the delivery of the substance to be dropped through the respective nozzles (16), characterized in that to each of said metering devices (8) is associated a respective actuating device (24) cooperating with the piston (12) of said metering device, said actuator device being operable individually to inhibit the delivery of the substance to be dropped through said nozzle (16) when the drive unit (100A, 100B) is actuated to cause displacement of the pistons of the metering devices associated therewith between the start position and the end position.

(Fig. 1)



SEARCH REPORT
in accordance with Article 35.1 a)
of the Luxembourg law on patents
dated 20 July 1992

LO 1683
LU 100315

DOCUMENTS CONSIDERED TO BE RELEVANT			
Category	Citation of document with indication, where appropriate, of relevant passages	Relevant to claim	CLASSIFICATION OF THE APPLICATION (IPC)
X	GB 784 064 A (CHRISTOPHER JOHN LEWIS WARREN; JOHN WILLIAM MILROSS) 2 October 1957 (1957-10-02)	1	INV. G01F11/00 A23G1/20 A23G3/02 A23G3/20 G01F11/02 B65B37/06 B65B37/20 B65B3/32
Y	* figures 1,2,4 *	2-12	
A	* claim 7 *	13	
	* page 1, line 11 - line 16 * * page 1, line 66 - line 68 * * page 2, line 49 - line 65 * * page 2, line 75 - line 82 * * page 2, line 92 - line 99 *		
X	US 2 296 861 A (JOHN MATTER ALBERT) 29 September 1942 (1942-09-29)	1	TECHNICAL FIELDS SEARCHED (IPC) G01F A23G B65B A21C B67C
	* figures 1,2 *		
	* page 1, line 1 - line 4 * * page 1, line 30 - line 34 * * page 2, line 4 - line 8 *		
Y	Martin J Bond ET AL: "Depositing -The Future of Hard Candy", 29 June 2016 (2016-06-29), XP055456507, www.fliphtml5.com (published by Guset User) Retrieved from the Internet: URL:http://online.fliphtml5.com/qjfd/qhdd/basic [retrieved on 2018-03-05] * page 12 - page 15; figures 7A,7B,8 *	2,3	
Y	US 2004/253148 A1 (LEATON JOHN R [US]) 16 December 2004 (2004-12-16)	4-6	
A	* figures 4B,6,7A,8A,10B,11B * * claim 2 * * paragraphs [0015], [0027], [0078], [0095] - [0097] * ----- -/-	13	
The present search report has been drawn up for all claims			
		Date of completion of the search 8 March 2018	Examiner Stitou, Adel
CATEGORY OF CITED DOCUMENTS		T : theory or principle underlying the invention E : earlier patent document, but published on, or after the filing date D : document cited in the application L : document cited for other reasons & : member of the same patent family, corresponding document	
X : particularly relevant if taken alone Y : particularly relevant if combined with another document of the same category A : technological background O : non-written disclosure P : intermediate document			

2
SFO-FC27M 1503 03 02 (P)X(C)551



SEARCH REPORT
in accordance with Article 35.1 a)
of the Luxembourg law on patents
dated 20 July 1992

LO 1683
LU 100315

DOCUMENTS CONSIDERED TO BE RELEVANT			
Category	Citation of document with indication, where appropriate, of relevant passages	Relevant to claim	CLASSIFICATION OF THE APPLICATION (IPC)
Y	S. V. Maffizoni: "Food Processing - Beverage & Packaging Special", 1 June 2016 (2016-06-01), XP055456397, Retrieved from the Internet: URL: http://www.editricezeus.net/archivio/FP/FP16_6.pdf [retrieved on 2018-03-05] * paragraph Feature 2.; page 50, column 2 *	7,8,12	
Y	US 2010/147419 A1 (BALNOSCHAN GREGORY A [US] ET AL) 17 June 2010 (2010-06-17) * figure 5 * * paragraphs [0003], [0023]-[0025] *	7,9-11	
Y	US 5 087 464 A (EBERHARDT ROLAND [DE] ET AL) 11 February 1992 (1992-02-11) * column 1, line 40 - line 44 * * column 2, line 49 - line 66 *	7	
A		13	
			TECHNICAL FIELDS SEARCHED (IPC)
The present search report has been drawn up for all claims			
		Date of completion of the search 8 March 2018	Examiner: Stitou, Adel
CATEGORY OF CITED DOCUMENTS		T : theory or principle underlying the invention E : earlier patent document, but published on, or after the filing date D : document cited in the application L : document cited for other reasons & : member of the same patent family, corresponding document	
X : particularly relevant if taken alone Y : particularly relevant if combined with another document of the same category A : technological background O : non-written disclosure P : intermediate document			

2
 SFO-FC27M 1003 03 02 (P) (C) (S)

**ANNEX TO THE SEARCH REPORT
ON LUXEMBOURG PATENT APPLICATION NO.**

LO 1683
LU 100315

This annex lists the patent family members relating to the patent documents cited in the above-mentioned European search report. The members are as contained in the European Patent Office EDP file on
The European Patent Office is in no way liable for these particulars which are merely given for the purpose of information.

08-03-2018

Patent document cited in search report		Publication date	Patent family member(s)	Publication date
GB 784064	A	02-10-1957	NONE	
US 2296861	A	29-09-1942	NONE	
US 2004253148	A1	16-12-2004	NONE	
US 2010147419	A1	17-06-2010	US 2010147419 A1 WO 2010074981 A1	17-06-2010 01-07-2010
US 5087464	A	11-02-1992	DE 3928864 A1 FR 2651096 A1 GB 2236041 A IT 1240977 B US 5087464 A	07-03-1991 01-03-1991 27-03-1991 27-12-1993 11-02-1992



WRITTEN OPINION

File No. LO1683	Filing date (day/month/year) 14.06.2017	Priority date (day/month/year)	Application No. LU100315
International Patent Classification (IPC) INV. G01F11/00 A23G1/20 A23G3/02 A23G3/20 G01F11/02 B65B37/06 B65B37/20 B65B3/02			
Applicant SOREMARTEC S.A.			

This report contains indications relating to the following items:

- Box No. I Basis of the opinion
- Box No. II Priority
- Box No. III Non-establishment of opinion with regard to novelty, inventive step and industrial applicability
- Box No. IV Lack of unity of invention
- Box No. V Reasoned statement with regard to novelty, inventive step or industrial applicability; citations and explanations supporting such statement
- Box No. VI Certain documents cited
- Box No. VII Certain defects in the application
- Box No. VIII Certain observations on the application

Form LU237A (Cover Sheet) (January 2007)	Examiner Stitou, Adel
--	--------------------------

WRITTEN OPINION

Application No.
LU100315

Box No. I Basis of the opinion

1. This opinion has been established on the basis of the latest set of claims filed before the start of the search.
2. With regard to any **nucleotide and/or amino acid sequence** disclosed in the application and necessary to the claimed invention, this opinion has been established on the basis of:
 - a. type of material:
 - a sequence listing
 - table(s) related to the sequence listing
 - b. format of material:
 - on paper
 - in electronic form
 - c. time of filing/furnishing:
 - contained in the application as filed.
 - filed together with the application in electronic form.
 - furnished subsequently.
3. In addition, in the case that more than one version or copy of a sequence listing and/or table relating thereto has been filed or furnished, the required statements that the information in the subsequent or additional copies is identical to that in the application as filed or does not go beyond the application as filed, as appropriate, were furnished.
4. Additional comments:

Box No. V Reasoned statement with regard to novelty, inventive step and industrial applicability; citations and explanations supporting such statement

1. Statement

Novelty	Yes: Claims	2-13
	No: Claims	1
Inventive step	Yes: Claims	13
	No: Claims	1-12
Industrial applicability	Yes: Claims	1-13
	No: Claims	
2. Citations and explanations
see separate sheet

WRITTEN OPINION

Application No.
LU100315

Box No. VIII Certain observations on the application

see separate sheet

Re Item V

1.1 Reference is made to the following documents:

- D1 GB 784 064 A (CHRISTOPHER JOHN LEWIS WARREN; JOHN WILLIAM MILROSS) 2 October 1957
- D2 US 2 296 861 A (JOHN MATTER ALBERT) 29 September 1942
- D3 Martin J Bond ET AL: "Depositing -The Future of Hard Candy",
, 29 June 2016 (2016-06-29), XP055456507,
www.fliphtml5.com (published by Guset User)
Retrieved from the Internet [retrieved on 2018-03-05]:
URL:<http://online.fliphtml5.com/qjfd/qhdd/basic>
- D4 US 2004/253148 A1 (LEATON JOHN R [US]) 16 December 2004
- D5 S. V. Maffizoni: "Food Processing - Beverage & Packaging Special",
, 1 June 2016 (2016-06-01), XP055456397,
Retrieved from the Internet [retrieved on 2018-03-05]:
URL:http://www.editricezeus.net/archivio/FP/FP16_6.pdf
- D6 US 2010/147419 A1 (BALNOSCHAN GREGORY A [US] ET AL) 17
June 2010
- D7 US 5 087 464 A (EBERHARDT ROLAND [DE] ET AL) 11 February
1992

1.2 **Independent Apparatus Claim 1**

Novelty

1.2.1 The present application does not meet the criteria of patentability, because the subject-matter of claim 1 is not new.

1.2.2 Document D1 discloses a dropper machine (*figure 1*):

- suitable for dropping a metered amount of a substance (*page 1 / lines 11-16*) in a plurality of receptacles (*page 1 / lines 66-68, claim 7: a plurality of individual plunger-cylinder pump is contemplated*)
- comprising:
 - a support structure (*figure 1: pillar 46 and shown associated frame*)

- a reservoir containing the substance to be dropped, supported by said structure (*figure 1: container 36*)
- a plurality of cylinder and piston type metering devices (*page 1 / lines 66-68, page 2 / lines 49-53, figure 1: a plurality of individual plunger 38 - cylinder 37 pump elements is contemplated*) with an inlet positioned below the level of the substance to be poured into the reservoir (*page 2 / lines 53-61, figure 1: ports 43*) and an outlet (*figure 1: fluid passage between the lower section of cylinder 37 and the top section of nozzle 39 through valve 40*) communicating with a respective dropper nozzle (*figure 1: nozzle 39*)
- at least one drive unit (*figures 1,4: cam 26 rotated by shaft 16*)
 - . arranged to simultaneously drive the pistons of said metering devices according to a forward and a backward motion between a start position and an end position (*page 2 / lines 75-82, figures 1,4: implied by the coordinated action of shaft 16, cam 26, follower 50, lever 48, rod 47, lever 44*)
 - . where the displacement of the pistons from the end position to the start position causes the suction of the substance to be dropped from the reservoir to the cylinder of the metering devices and the displacement of the pistons from the start position to the end position is adapted to cause the delivery of the substance to be dropped through the respective nozzles (*page 2 / lines 53-65, figure 1: coordinated action of plunger 38, cylinder 37 / port 43, nozzle 39, valve 40*)
- wherein:
 - to each of said metering devices is associated a respective actuating device cooperating with the piston of said metering device (*page 2 / lines 92-99, figures 1,2: elements 52-54 interacting on the movement of plunger 38 through elements 47,44*)
 - said actuator device being operable individually to inhibit the delivery of the substance to be dropped through said nozzle when the drive unit is actuated to cause the displacement of the pistons of the metering devices associated therewith between the start position and the end position (*page 2 / lines 92-99, figures 1,4: when the cut-out control mechanism is effected, the reciprocating movement of the piston is blocked while cam 26 is actuated*)

1.2.3 It is to be noted that the same conclusion on novelty can alternatively be reached from the disclosure of document D2 (*page 1 / lines 1-4 / lines 30-34, page 2 / lines 4-8, figures 1,2*).

1.3 **Dependent Claims 2-12**

1.3.1 **Inventive Step**

Dependent claims 2-12 do not appear to contain any additional features which, in combination with the features of any claim to which they refers, meet the requirements of inventive step.

Document D1 is considered the closest prior art for claims 2-12.

Claim 2

When tasked with the objective technical problem to simplify the use of the apparatus of D1 by integrating both the provisioned variation of the dispensed volume (*D1 explains that adjusting the length of actuated rods & levers allows adjusting the stroke of the dispensing plunger*) and the deactivation of the individual dispensing pump, the skilled person will certainly review known solid-liquid dispensing systems.

The skilled person would be aware of document D3, dealing with metered deposition in bakery (*page 12,13, figures 7a,7b*), which explains that shifting the effective stroke of the piston of a dispensing pump, using a servo-drive allows adjusting the dispensed volume (*pages 14,15*) and that, in particular, the more the piston stroke is offset upwards, the less volume is dispensed through the nozzle (*page 14 / 4th paragraph, figure 8*).

The skilled person would recognise that this arrangement can fulfil both the desired volume variation functionality (setting piston stroke offset as needed) and the dispensing inhibition functionality (setting the piston stroke offset high enough).

The skilled person will therefore apply the arrangement of D3 to the apparatus of D1, which effectively implies the features introduced by claim 2 (*in deactivation position, if raised enough, figure 8 shows that the effective stroke of the piston would result in no dispensed volume through the nozzle and that the movement of the piston would reflow the liquid into the main container*), and would therefore arrive to the subject-matter of claim 2 without exercising inventive skills.

Claim 3

Document D3 mentions (*page 15 / 1th paragraph*) that the profile of the piston stroke can advantageously be adjusted nowadays through the use of servo-drive.

The configuration introduced by claim 3 constitutes merely a realisation mode of the general principle explained by document D3, which comes within the customary design practice followed by persons skilled in the art.

Claim 4

The objective technical problem solved by the features introduced by claim 4 can be viewed as to adapt the apparatus of D1 to allow the filling of series of receptacles arranged with an interaxial distance different from the one of the original configuration of the apparatus of D1.

The skilled person would be aware of document D4 dealing with liquid handling automation equipment (*[0027]*), in particular the transfer of liquids between multiples containers (*[0015]*), and which discloses an arrangement (*figures 4B, 6, 7A, 8A, 10B, 11B*) with nozzles (*elements 42*) connected the source of liquid to be dispensed by means of hoses which allow the interaxial distance between nozzles to be varied (*elements 43*) and wherein said nozzles engage the cams of a cam device (*[0078], [0095], [0096]*) operable in a plurality of operative positions to cause the variation of the interaxial distance between the nozzles (*[0027]*).

The skilled person would therefore regard it as a normal design option to apply the teaching of D4 (effectively implementing the features introduced by claim 4) to the apparatus of D1, to provide the same advantages, thereby arriving at the subject-matter of claim 4, without exercising inventive skills.

Claim 5

The features introduced by claim 5 do not introduced a surprising technical effect over the cam device of document D4 (*[0078], [0095], [0096], figures 8A, 10B: plates 61 & 63 slidably connected to each other, nozzle holders 54 engaged in the cam slots of plate 63 through pin 56*) and, indeed, merely constitute a slight change in constructional details, which comes within the scope of the customary practice followed by persons skilled in the art, without involving inventive skills.

Claim 6

Document D4 discloses that the cam device (*figure 10B: plates 61 & 63*) is actuated by means of an actuating device (*figure 10B: element 57*), which allows the positioning of said first and second plate relative to each other in a plurality of operative position (*[0097]*).

Claim 7

Noting the remark made in Re Item VIII, the implementation of the features introduced by claim 7 (effectively gathering information on the receptacles to be filled) is generally known when the type of apparatus of D1 is used in automated for food processing.

Document D5 discloses (*page 50 / column 2 / paragraph Feature 2*) a depositor working on the *no product - no fill* principle equipped with a read device adapted to generate a signal (*vision system*) which allows:

- (i) the identification of any defective receptacles or receptacles not conforming the productions specifications (*missing or broken bases to be filled are detected*)
- (ii) the determination of the location of the aforementioned defective receptacles, in the support plate wherein they are housed (*implied by the no product - no deposit process*)

[and / or ...]

The skilled person would therefore regard it as a normal design option to apply the teaching of documents D5 (effectively implement the features introduced by claim 7) to the apparatus of D1, to provide the same advantage (*the so-called no product - no fill principle*), thereby arriving at the subject-matter of claim 7, without exercising inventive skills.

It is to be noted that the same conclusion can alternatively be reached by incorporating the teaching of other documents:

- D6 (*[0003], [0023]-[0025], figure 5: RFID or barcode on tray of cups to be filled informs the control system on various information such as, the quantity to be deposited, the geometrical properties & arrangements of the tray & cups*)
- D7 (*statement of the technical problem on column 1 / lines 40-44 and the general principle of the invention on column 2 / lines 49-66, which explains that an optical-based control system allows to adjust the spatial position of the deposition in accordance with the actual location of the receptacles to deal with non-conforming production events*)

Claim 8

Document D5 discloses (*page 50 / column 2 / paragraph Feature 2*) that the said read device is an image recording device (*vision system*).

Claim 9

Document D6 discloses that the said read device comprises an electronic unit ([0023], *figure 5: detector 76*) arranged to received a signal identifying the parameters and features of the receptacles wherein the fluid substance is to be metered ([0024],[0025]: *RFID or barcode informs on various information, such as the quantity to be deposited*) and of their locations in the related support plates ([0024],[0025]: *RFID or barcode the geometrical properties & arrangements of the tray & cups*).

Claim 10

Document D6 discloses ([0024]) the use of RFID and barcodes.

Claim 11

Document D6 specifically discloses ([0024]) the use of RFID, and therefore also, implicitly, the features introduced by claim 11 (read / write information on an embedded memory, contact-less data transmission through antennas).

Claim 12

The features introduced by claim 12 effectively consists in the practical implementation of the *no product-no deposit* principle disclosed in document D5 (*page 50 / column 2 / paragraph Feature 2*) on the apparatus of D1, noting that motorising & electronically controlling the cut-off of each individual piston-cylinder pair merely constitute nowadays a slight change in constructional details, which comes within the scope of the customary practice followed by persons skilled in the art.

1.4 **Dependent Claim 13**

The remark on claim dependence made in Re Item VIII is to be noted.

Subsequently, it is also to be noted that, in the subject-matter of claim 13, the implementation of the said cam device (cf. preamble of claim 13 referring to claim 4) and the implementation of a control system (i.e. features introduced by claims 7 & 13) constitute two different functionalities solving two different technical problems.

The implementation of the said cam device is discussed above (cf. claim 4) and it was concluded that adding this functionality to the apparatus of D1 does not involve, on its own, an inventive step in view of the teaching of D4.

The implementation of the said control system as characterised in the subject-matter of 13 indeed interacts with the cam device functionality and appears therefore to be synergetic with it.

While D4 contemplates (*claim 2*) controlling cam device in the context of an automated production, it does not specifically disclose the details of it.

In order to come to the subject-matter of claim 13, the skilled person would hence, need, in addition to combining the knowledge of D1 & D4, to also combine the teaching of D7 (cf. above), which would require an inventive step.

Re Item VIII

1.5 Additional Remarks

Claim 7

In accordance with the description (*page 9 / line 19 - page 10 / line 10, figure 10*), it is understood and considered in the present Written Opinion that the generated signal referred in claim 7 allows:

- feature (i) & (ii) together

and/or

- feature (iii)

Claim 13

The features introduced by claim 13 refers to the cam device allowing to vary the interaxial distance between the nozzles, which is indeed featured in claim 4.

Since claim 13 refers in its preamble to claim 7 and that claim 7 refers in its preamble to '*any preceding claims*' (therefore also including the ones not including the features of claim 4), there is an inconsistency in the claim dependence.

Accordingly, it is considered in the present Written Opinion that claim 13 refers to both claims 7 and 4 in its preamble.