

(19) World Intellectual Property Organization  
International Bureau



(43) International Publication Date  
20 February 2003 (20.02.2003)

PCT

(10) International Publication Number  
WO 03/014822 A2

(51) International Patent Classification<sup>7</sup>: G02F 1/35

Adrian, Petru [RO/GB]; 59 Runnymede, London SW19 2PG (GB). DAY, Ian [GB/GB]; 10 Chestnut Avenue, Headington, Oxford OX3 9JH (GB).

(21) International Application Number: PCT/GB02/03481

(22) International Filing Date: 29 July 2002 (29.07.2002)

(74) Agents: DRIVER, Virginia, Rozanne et al.; Page White & Farrer, 54 Doughty Street, London WC1N 2LS (GB).

(25) Filing Language: English

(81) Designated States (*national*): AE, AG, AL, AM, AT, AU, AZ, BA, BB, BG, BR, BY, BZ, CA, CH, CN, CO, CR, CU, CZ, DE, DK, DM, DZ, EC, EE, ES, FI, GB, GD, GE, GH, GM, HR, HU, ID, IL, IN, IS, JP, KE, KG, KP, KR, KZ, LC, LK, LR, LS, LT, LU, LV, MA, MD, MG, MK, MN, MW, MX, MZ, NO, NZ, OM, PH, PL, PT, RO, RU, SD, SE, SG, SI, SK, SL, TJ, TM, TN, TR, TT, TZ, UA, UG, US, UZ, VN, YU, ZA, ZM, ZW.

(26) Publication Language: English

(30) Priority Data:  
0119369.7 8 August 2001 (08.08.2001) GB

(71) Applicant (*for all designated States except US*):  
BOOKHAM TECHNOLOGY PLC [GB/GB]; 90 Milton Park, Abingdon, Oxon OX1 4RY (GB).

(84) Designated States (*regional*): ARIPO patent (GH, GM, KE, LS, MW, MZ, SD, SL, SZ, TZ, UG, ZM, ZW), Eurasian patent (AM, AZ, BY, KG, KZ, MD, RU, TJ, TM), European patent (AT, BE, BG, CH, CY, CZ, DE, DK, EE,

(72) Inventors; and

(75) Inventors/Applicants (*for US only*): VONSOVICI,

[Continued on next page]

(54) Title: OPTIC SYSTEM

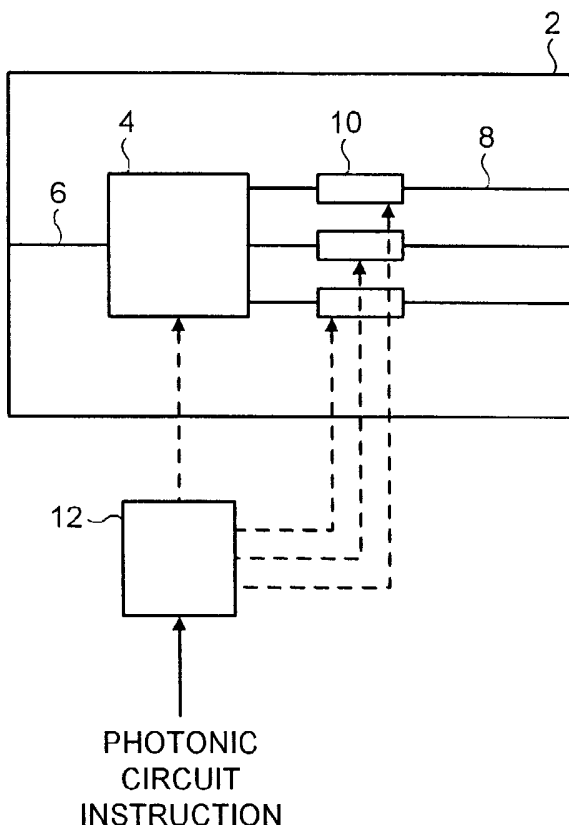

(57) Abstract: An optic system including: an integrated optical device including an electrically controllable photonic circuit element for receiving an optical signal from at least one optical path and selectively directing the optical signal to a selected one or more of a plurality of optical output paths, and being electrically adjustable between a plurality of states at which the input optical signal is selectively directed to a different output path or combination of output paths; electrically controllable pin diode attenuating elements associated with each of the output paths; and electrical circuitry for controlling the pin diode attenuating elements in co-ordination with the photonic circuit element such that the pin diode attenuating elements associated with the one or more selected paths are in an on state, and the pin diode attenuating elements associated with output paths other than the selected paths are in an off state to substantially extinguish any signal power in those output paths.



WO 03/014822 A2



ES, FI, FR, GB, GR, IE, IT, LU, MC, NL, PT, SE, SK, TR), OAPI patent (BF, BJ, CF, CG, CI, CM, GA, GN, GQ, GW, ML, MR, NE, SN, TD, TG).

*For two-letter codes and other abbreviations, refer to the "Guidance Notes on Codes and Abbreviations" appearing at the beginning of each regular issue of the PCT Gazette.*

**Published:**

— *without international search report and to be republished upon receipt of that report*

## OPTIC SYSTEM

The present invention relates to an optic system, in particular to an optic system including an electrically controllable photonic circuit element for receiving an optical signal from at least one optical path and selectively directing the optical signal to a selected one or more of a plurality of output paths.

Generally, interferometric-type switching elements tend to suffer from the problem that a small residual portion of the input signal enters output paths other than that or those to which it is desired to direct the input signal. The degree to which this occurs is referred to as the cross-talk performance of the system. In theory, this could be avoided using splitters and combiners that are precisely balanced in power in such a way that the correct phase difference is achieved between different optical paths. However, it has been observed that this perfect balance of powers can be difficult to achieve in practice and is also very sensitive to fabrication errors. It has also been observed that there is a similar problem with non-interferometric type switches, such as digital optical switches, in that refractive index differences between the two output arms are limited by the electro-optical effect used.

It is an aim of the present invention to provide an optic system with which the problem of cross-talk can be substantially eliminated.

According to a first aspect of the present invention, there is provided an optic system including: an integrated optical device including an electrically controllable photonic circuit element for receiving an optical signal from at least one optical path and selectively directing the optical signal to a selected one or more of a plurality of optical output paths, and being electrically adjustable between a plurality of states at which the input optical signal is selectively directed to a different output path or combination of output paths; electrically controllable attenuating elements associated with each of the output

paths; and electrical circuitry for controlling the attenuating elements in coordination with the photonic circuit element such that the attenuating elements associated with the one or more selected paths are in an on state, and the attenuating elements associated with output paths other than the selected paths are in an off state to substantially extinguish any signal power in those output paths.

An embodiment of the present invention is described hereunder, by way of example only, with reference to the accompany figure showing a schematic view thereof.

With reference to Figure 1, an optic system according to a first embodiment of the present invention includes a silicon-on-insulator (SOI) chip 2 having defined therein an electrically controllable photonic circuit 4 for selectively directing an optical signal from input waveguide 6 to a selected one of three output waveguides 8. Each output waveguide 8 is provided with an in-line attenuating element 8, which can be switched from an "on" state in which it applies a zero or low degree of attenuation, and an "off" state in which it applies a high degree of attenuation.

The photonic circuit 4 may, for example, be an interferometric type switch such as a Mach-Zehnder switch or a non-interferometric-type switch such as digital optical switch. The desired output path is selected by controlling an electric signal to the switch.

The in-line attenuating element may for example be a pin diode attenuating element 6 that includes n-doped and p-doped regions on either side of the waveguide 8, such that charge carriers can be injected into the waveguide upon application of an appropriate voltage across the n-doped and p-doped regions. The injection of charge carriers into the waveguide increases the absorption of the waveguide with respect to the optical signal and thus increases the

attenuation of the optical signal. The attenuating element can be switched between the on and off states by controlling the voltage applied across the n-doped and p-doped regions. The pin diode attenuating element 6 may have a structure as described in co-pending UK patent applications no. GB0019971.5 or GB0104384.3, whose contents are incorporated herein by reference. Alternatively, other types of in-line attenuating elements that operate by absorption effects could be used.

A processor 12 controls both the photonic circuit and the attenuating elements in co-ordination with each other in accordance with a command specifying the output waveguide to which the input signal should be directed, such that only that attenuating element associated with the selected output waveguide is maintained in an "on" state to allow the propagation of the optical signal along that waveguide, with the remaining attenuating elements associated with the non-selected output waveguides being switched to an "off" state to extinguish any minor portion of the power of the input signal that may have entered those output waveguides.

The pin diode attenuating elements used in the above-described embodiment are a preferred type of in-line attenuating element for this invention because they exhibit low insertion loss and low polarisation dependency, but can achieve high levels of attenuation greater than -20dB.

In the above-described embodiment, the present invention is applied to an optical switch as part of an SOI integrated device. However, the present invention is also applicable to other types of systems such as devices based on polymers and other semiconductor materials such as III-V.

The applicant draws attention to the fact that the present invention may include any feature or combination of features disclosed herein either implicitly or explicitly or any generalisation thereof, without limitation to the scope of any

definitions set out above. In view of the foregoing description it will be evident to a person skilled in the art that various modifications may be made within the scope of the invention.

## CLAIMS:

1. An optic system including: an integrated optical device including an electrically controllable photonic circuit element for receiving an optical signal from at least one optical path and selectively directing the optical signal to a selected one or more of a plurality of optical output paths, and being electrically adjustable between a plurality of states at which the input optical signal is selectively directed to a different output path or combination of output paths; electrically controllable attenuating elements associated with each of the output paths; and electrical circuitry for controlling the attenuating elements in co-ordination with the photonic circuit element such that the attenuating elements associated with the one or more selected paths are in an on state, and the attenuating elements associated with output paths other than the selected paths are in an off state to substantially extinguish any signal power in those output paths.
2. An optic system according to claim 1, wherein the attenuating elements are in-line attenuating elements.
3. An optic system according to claim 1, wherein the attenuating elements are electro-optic attenuating elements.
4. An optic system according to claim 3, wherein the attenuating elements are pin diode attenuating elements.
5. An optic system according to claim 1, wherein the integrated device is a silicon-on-insulator device, with the input and output optical paths, the switching element and the attenuating elements being defined in a layer of silicon.

6. An optic system according to claim 1, wherein the input and output optical paths are rib waveguides.
7. An optic system according to any preceding claim wherein the photonic element is selected from the group consisting of a integrated Mach-Zehnder interferometer, a multi-mode interference (MMI) coupler, and a digital optical switch.
8. An optic system including: an integrated optical device including an electrically controllable photonic circuit element for receiving an optical signal from at least one optical path and selectively directing the optical signal to a selected one or more of a plurality of optical output paths, and being electrically adjustable between a plurality of states at which the input optical signal is selectively directed to a different output path or combination of output paths; electrically controllable pin diode attenuating elements associated with each of the output paths; and electrical circuitry for controlling the pin diode attenuating elements in co-ordination with the photonic circuit element such that the pin diode attenuating elements associated with the one or more selected paths are in an on state, and the pin diode attenuating elements associated with output paths other than the selected paths are in an off state to substantially extinguish any signal power in those output paths.

