

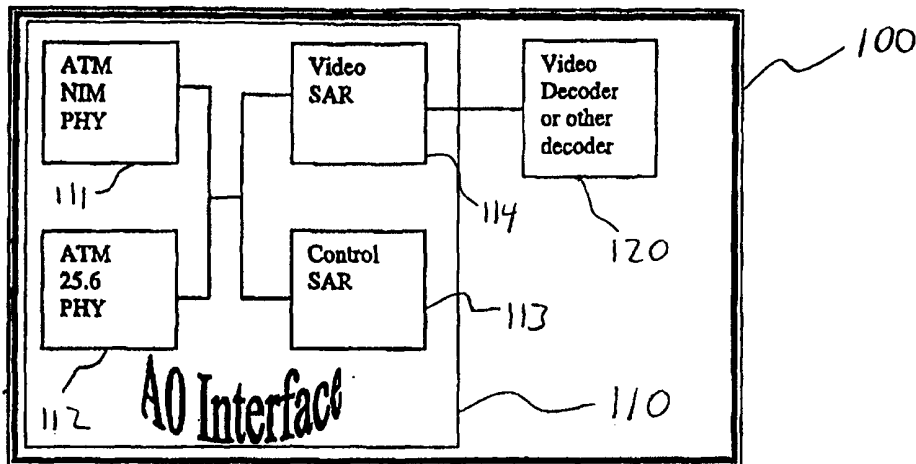

INTERNATIONAL APPLICATION PUBLISHED UNDER THE PATENT COOPERATION TREATY (PCT)

<p>(51) International Patent Classification <sup>6</sup> : <b>H04H 1/02, H04N 7/14</b></p>	<p><b>A1</b></p>	<p>(11) International Publication Number: <b>WO 00/07309</b>  (43) International Publication Date: 10 February 2000 (10.02.00)</p>
<p>(21) International Application Number: PCT/US99/17435 (22) International Filing Date: 30 July 1999 (30.07.99)  (30) Priority Data: 60/094,825 31 July 1998 (31.07.98) US  (71) Applicant: CELERITY SYSTEMS, INCORPORATED [US/US]; 1400 Centerpoint Boulevard, Knoxville, TN 37932 (US).  (72) Inventors: WEST, Glenn; 3JLN Membina, #02-04, Singapore 169480 (SG). BRUMGARD, David, E.; 1825 Greenwell Drive, Knoxville, TN 37938 (US). BROUSSARD, Roger, M.; 315 Broady Lane, Maryvile, TN 37803 (US). CROMWELL, Mark, C.; 3837 Keowee Avenue, Knoxville, TN 37919 (US). SMITH, Dennis, K.; 11604 Lanesborough Way #207, Farragut, TN 38922 (US).  (74) Agents: GOLDMAN, Gregg, I. et al.; Proskauer Rose LLP, 1585 Broadway, New York, NY 10036 (US).</p>		<p>(81) Designated States: AE, AL, AM, AT, AU, AZ, BA, BB, BG, BR, BY, CA, CH, CN, CU, CZ, DE, DK, EE, ES, FI, GB, GD, GE, GH, GM, HR, HU, ID, IL, IN, IS, JP, KE, KG, KP, KR, KZ, LC, LK, LR, LS, LT, LU, LV, MD, MG, MK, MN, MW, MX, NO, NZ, PL, PT, RO, RU, SD, SE, SG, SI, SK, SL, TJ, TM, TR, TT, UA, UG, UZ, VN, YU, ZA, ZW, ARIPO patent (GH, GM, KE, LS, MW, SD, SL, SZ, UG, ZW), Eurasian patent (AM, AZ, BY, KG, KZ, MD, RU, TJ, TM), European patent (AT, BE, CH, CY, DE, DK, ES, FI, FR, GB, GR, IE, IT, LU, MC, NL, PT, SE), OAPI patent (BF, BJ, CF, CG, CI, CM, GA, GN, GW, ML, MR, NE, SN, TD, TG).</p> <p><b>Published</b> <i>With international search report.</i></p>

(54) Title: TELEVISION SET TOP BOX



(57) Abstract

A television set top box (100) includes an AO interface (110), such as DAVIC (Digital Audio Visual Counsel), which is internally coupled to dual Segmentation and Reassembly (SAR) controllers (113). Within the AO interface (110), the set top box (100) includes an internal connector and internal Network Interface Module (NIM) (111). An External Reader is affixed to the set top box (100) for reading signals from an external security device, such as an iButton. The set top box (100) also supports IrDA (Infrared Data Association), an infrared based communications protocol, as well as CE (Consumer Electronics)-BUS for household electronics control. The set top box (100) further includes a dedicated infrared (I/R) processor to reduce the functions of a primary processor in the set top box (100). In addition, the set top box (100) includes karaoke input jacks for mixing singers with music.

**FOR THE PURPOSES OF INFORMATION ONLY**

Codes used to identify States party to the PCT on the front pages of pamphlets publishing international applications under the PCT.

<b>AL</b>	Albania	<b>ES</b>	Spain	<b>LS</b>	Lesotho	<b>SI</b>	Slovenia
<b>AM</b>	Armenia	<b>FI</b>	Finland	<b>LT</b>	Lithuania	<b>SK</b>	Slovakia
<b>AT</b>	Austria	<b>FR</b>	France	<b>LU</b>	Luxembourg	<b>SN</b>	Senegal
<b>AU</b>	Australia	<b>GA</b>	Gabon	<b>LV</b>	Latvia	<b>SZ</b>	Swaziland
<b>AZ</b>	Azerbaijan	<b>GB</b>	United Kingdom	<b>MC</b>	Monaco	<b>TD</b>	Chad
<b>BA</b>	Bosnia and Herzegovina	<b>GE</b>	Georgia	<b>MD</b>	Republic of Moldova	<b>TG</b>	Togo
<b>BB</b>	Barbados	<b>GH</b>	Ghana	<b>MG</b>	Madagascar	<b>TJ</b>	Tajikistan
<b>BE</b>	Belgium	<b>GN</b>	Guinea	<b>MK</b>	The former Yugoslav Republic of Macedonia	<b>TM</b>	Turkmenistan
<b>BF</b>	Burkina Faso	<b>GR</b>	Greece			<b>TR</b>	Turkey
<b>BG</b>	Bulgaria	<b>HU</b>	Hungary	<b>ML</b>	Mali	<b>TT</b>	Trinidad and Tobago
<b>BJ</b>	Benin	<b>IE</b>	Ireland	<b>MN</b>	Mongolia	<b>UA</b>	Ukraine
<b>BR</b>	Brazil	<b>IL</b>	Israel	<b>MR</b>	Mauritania	<b>UG</b>	Uganda
<b>BY</b>	Belarus	<b>IS</b>	Iceland	<b>MW</b>	Malawi	<b>US</b>	United States of America
<b>CA</b>	Canada	<b>IT</b>	Italy	<b>MX</b>	Mexico	<b>UZ</b>	Uzbekistan
<b>CF</b>	Central African Republic	<b>JP</b>	Japan	<b>NE</b>	Niger	<b>VN</b>	Viet Nam
<b>CG</b>	Congo	<b>KE</b>	Kenya	<b>NL</b>	Netherlands	<b>YU</b>	Yugoslavia
<b>CH</b>	Switzerland	<b>KG</b>	Kyrgyzstan	<b>NO</b>	Norway	<b>ZW</b>	Zimbabwe
<b>CI</b>	Côte d'Ivoire	<b>KP</b>	Democratic People's Republic of Korea	<b>NZ</b>	New Zealand		
<b>CM</b>	Cameroon			<b>PL</b>	Poland		
<b>CN</b>	China	<b>KR</b>	Republic of Korea	<b>PT</b>	Portugal		
<b>CU</b>	Cuba	<b>KZ</b>	Kazakstan	<b>RO</b>	Romania		
<b>CZ</b>	Czech Republic	<b>LC</b>	Saint Lucia	<b>RU</b>	Russian Federation		
<b>DE</b>	Germany	<b>LI</b>	Liechtenstein	<b>SD</b>	Sudan		
<b>DK</b>	Denmark	<b>LK</b>	Sri Lanka	<b>SE</b>	Sweden		
<b>EE</b>	Estonia	<b>LR</b>	Liberia	<b>SG</b>	Singapore		

TELEVISION SET TOP BOX

---

5

FIELD OF THE INVENTION

The present invention relates to video and audio communications, and more specifically, the present invention relates to a set top box configuration for use with a television set.

10

BACKGROUND OF THE INVENTION

Set top boxes for television sets are widely used for selecting a particular program from a group of transmitted signals. For example, an encoded MPEG-2 transport stream transmission can be received and decoded by a subscriber-controlled set top box which includes an appropriate MPEG-2 demultiplexer and decoder. In similar fashion, an asynchronous transfer mode (ATM) segmented transmission can be received and reassembled by a subscriber-controlled set top box which includes conventional ATM network processing techniques.

15

In the prior art generally, set top boxes are limited to a specific application, such as tuning cable channels and more recently, Internet access. However, with rapid advances in technology and in user applications, there is a need for a multi-purpose set top box with high versatility.

20

Accordingly, it is an object of the present invention to provide a television set top box with a wide range of application capabilities.

25

SUMMARY OF THE INVENTION

In accordance with an illustrative embodiment of the present invention, a television set top box includes an A0 (UTOPIA) compliant interface, connected in serial or parallel format to dual SAR (Segmentation and Reassembly) controllers. One SAR controller handles  
5 network protocol data transfers, while the other SAR controller receives multiple real-time video and other data inputs. A decoder is connected to the output of the latter SAR controller for decoding the video and other data inputs.

The inventive set top box is also designed to incorporate the following built-in features:

- 10 a) a Digital Subscriber Line (DSL) modem, such as an Asymmetric Digital Subscriber Line (ADSL) or a Very High Speed Digital Subscriber Line (VDSL), Network Interface Module (NIM) connected to the A0 interface;
- b) a plurality of Universal Serial Bus (USB) ports, compatible with the USB peripheral bus standard, for peripheral support expansion capabilities;
- 15 c) an External Reader for reading input signals from an external security device, such as an iButton computer chip containing security information for access control and electronic transactions;
- d) an internal dedicated infrared (I/R) processor for interpreting  
20 commands from external I/R devices, such that these commands are converted into keyboard commands;
- e) a Web browser program, within which applications are designed to trigger video control functions, using techniques such as DSM-CC (Digital Storage Media - Control Commands) on top of CORBA (Common Object Request Broker Architecture);
- f) an IrDA (Infrared Data Association) port, compatible with IrDA

infrared based communications protocol and hardware, which enables wireless communication between the set top box and an external device, such as a laptop, palmtop or printer;

g) a plurality of karaoke jacks for receiving sound inputs, such as singers, or music, which can be mixed and enhanced with special effects;

5 h) a Smart Card Reader for reading input signals from an external Smart Card device, which enables electronic transactions and access control; and

i) a CE (Consumer Electronics)-BUS interface for supporting the CE-BUS industry standard for power communications, which enables the set top box to monitor and/or control household electronics, energy management, electric power meter reading,  
10 security sensors and medical device monitoring.

An illustrative embodiment of the present invention is more fully described below in conjunction with the following drawings.

#### BRIEF DESCRIPTION OF THE DRAWINGS:

15 FIG 1 shows a block diagram of a set top box having a decoder and an A0 compliant interface in accordance with the present invention.

FIG 2 schematically illustrates the inventive set top box, with a DAVIC (Digital Audio Visual Counsel) A0 interface in accordance with the present invention.

20 FIG 3 shows a block diagram of the inventive set top box with an internal ADSL modem Network Interface Module (NIM) in accordance with the present invention.

FIG 4 schematically illustrates the inventive set top box schematically, with an internal ADSL modem in accordance with the present invention.

FIG 5 schematically illustrates the inventive set top box schematically, incorporating Universal Serial Buses (USBs) in accordance with the present invention.

FIG 6 schematically illustrates the inventive set top box schematically, incorporating an External Reader for reading signals from an external security device in accordance with the present invention.

FIG 7 schematically illustrates the inventive set top box schematically, incorporating an  
5 infrared (I/R) dedicated processor.

FIG 8 depicts a common object request broker architecture (CORBA), within the Web browser of the inventive set top box.

FIG 9 depicts the inventive set top box with an IrDA port for supporting the IrDA communications protocol in accordance with the present invention.

10 FIG 10 illustrates the inventive set top box schematically, incorporating karaoke jacks in accordance with the present invention.

FIG 11 illustrates the inventive set top box schematically, incorporating a Smart Card Reader in accordance with the present invention.

15 FIG 12 illustrates the inventive set top box schematically, incorporating a CE-BUS interface in accordance with the present invention.

#### DETAILED DESCRIPTION OF THE INVENTION

An illustrative embodiment of the present invention is shown in simplified block diagram form in FIG 1. A television set top box 100 includes an A0 compliant interface 110  
20 (e.g., a DAVIC A0 Interface) and a video, or other type of, decoder 120.

The DAVIC A0 Interface is comprised of one or more Physical level interfaces (111, 112), connected over a cell bus in serial or parallel format to a dual Segmentation and Reassembly (SAR) control configuration. Control SAR 113 handles the control of normal network connections, such as transporting a standard transport protocol, e.g., TCP/IP

(Transmission Control Protocol/Internet Protocol) data, over the ATM, or other protocol which may be needed in the application. Video SAR 114 receives multiple real-time data inputs, such as video data. A more detailed block diagram of the inventive set top box 100 and the DAVIC A0 Interface 110 is shown in FIG 2.

5 Numerous additional features are incorporated into the inventive set top box 100. They are described below in relation to the configurations of FIGs 1 and 2. However, note that FIGs 2, 4-7 and 10-12 illustrate other conventional modules that are contained in the inventive set top box 100, which are known to one skilled in the art, and, for the sake of brevity, will not be described herein.

10 a) The A0 interface 110 within set top box 100 includes an internal connector (not shown) and provision for mechanically mounting an ADSL modem Network Interface Module (NIM) 115. This internal NIM configuration precludes the need for an external modem solution, as is typical in the prior art. FIGs 3 and 4 illustrate the ADSL modem 115 connection within A0 interface 110.

15 b) Traditionally, set top boxes lack expansion slots. Moreover, if expansion slots were to be introduced into set top boxes, the users would be required to open the box, creating a situation generally considered to be unacceptable by network operators. However, an expansion capability for set top boxes without the use of expansion slots can be achieved by means of Universal Serial Buses (USBs). A USB is a peripheral bus standard developed  
20 by PC and telecommunication industry leaders which allows plug and play of computer peripherals outside the set top box. Thus, the need to install cards into dedicated computer slots and to reconfigure the system is eliminated. Personal computers equipped with USB will allow computer peripherals to be automatically configured as soon as they are physically connected, without the need to reboot or run setup. In addition, each USB will also allow

multiple devices, up to 127, to run simultaneously on a computer, with peripherals such as monitors and keyboards acting as additional plug-in sites or hubs.

As shown in FIG 5, inventive set top box 100 incorporates a USB interface 130, which can support a variety of peripherals, such as digital cameras, printers, joysticks, wired  
5 keyboards, and infrared interfaces.

c) Another feature which may be incorporated into a set top box for security purposes is an "External Reader." That is, for access control and electronic transactions, a device is needed to read signals from an external security device to ensure the security of set top box transactions.

10 An External Reader 140, which is attached to set top box 100, is shown in FIG 6. Illustratively, External Reader 140 is used to read signals from an "iButton" when the iButton is touched to it.

An iButton is a coin-like device which may comprise ROM, RAM or a small CPU. It is a 16mm computer chip housed in a stainless steel can. The iButton can be worn by a person  
15 or attached to an object for up-to-date information at the point of use. Preferably, the steel iButton is rugged enough to withstand harsh outdoor environments and is durable enough for a person to wear every day on a digital accessory, such as a ring, key fob, wallet, watch or badge.

d) The inventive set top box 100 may further include a dedicated infrared (I/R)  
20 processor. This I/R processor is used to interpret commands sent via I/R light from a device, such as a hand-held remote or an I/R keyboard. This approach offloads the primary processor in the set top box, and allows the primary processor to perform its functions without the additional burden of I/R processing. As a result, the I/R process reliability is improved. This dedicated I/R processor front-end can be configured to use flash memory, downloaded from



the host. This removes unnecessary overhead from the host, and still allows for fully changeable protocols and remote controls from the front-end. With this programmability, the I/R processor front-end can also take several different devices, including the I/R, and make them appear to the main processor like a keyboard input. These devices include: I/R hand-  
5 held remote, I/R Keyboard, iButton Security Device, Front Panel Keys and LED's.

An I/R dedicated processor front-end 150 is shown in FIG 7, connected to the I/R port of set top box 100.

e) Another feature of the inventive set top box 100 relates to its software configuration. Within the Web browser of set top box 100, applications are designed to  
10 trigger video control functions, using techniques such as DSM-CC on top of CORBA. CORBA (Common Object Request Broker Architecture) is a specification of an architecture and interface that allows an application to make requests of objects (servers) in a transparent, independent manner. This is regardless of platform, operating system or locale considerations. The software hierarchy for this process in set top box 100 is depicted in FIG 8.

f) In the prior art, set top boxes have not supported IrDA, which is an infrared based communications protocol and hardware that allows two or more devices to communicate without a wired connection. The inventive set top box 100 includes an IrDA port, as depicted in FIG 9. With this IrDA capability, set top box 100 can be used to receive e-mail from a laptop or palmtop, by placing the set top box in the proximity of the laptop or  
20 palmtop. Moreover, the set top box with IrDA capability could also be used to print out a document/web-page or menu, for example, to a printer 155 without a wire connection. Still another application area for an IrDA-equipped set top box is that of electronic transactions.

g) The inventive set top box 100 can also be equipped with a plurality of karaoke jacks, as shown in FIG 10. The karaoke inputs are designated as 160, and are connected to

the Sound module within set top box 100. This provides the capability of, for example, mixing two singers or adding special effects to singers, to music, or to a music video.

h) Set top box 100 also provides support for a Smart Card Reader 170, as depicted in FIG 11. A Smart Card is a plastic card embedded with a microprocessor that has the potential to perform myriad functions--from storing and transferring cash to holding entire credit and medical histories. A Smart Card Reader-equipped set top box, therefore, can accommodate all types of electronic transactions, as well as access control functions.

i) Still another feature of set top box 100 is the incorporation of a CE-BUS interface. CE-BUS is an industry standard for communications, using various media, including the power line. With a CE-BUS interface capability, set top box 100 can be used, for example, for controlling household lights and appliances, for energy management, and for reading an electric power meter, to name a few. FIG 12 shows the CE-BUS 180 interface configuration within set top box 100.

In short, a highly versatile set top box is disclosed, with a diverse feature set, including a DAVIC A0 interface with dual SAR, an internal ADSL modem NIM, an attached External Reader, a dedicated I/R processor, and support for USB, IrDA, Smart Cards, and CE-BUS.

Moreover, the disclosed set top box contains Web browser software which triggers video control functions using DSM-CC on top of CORBA.

The above described embodiments of the invention are intended to be illustrative only. Numerous alternative embodiments may be devised by those skilled in the art without departing from the spirit and scope of the following claims.

CLAIMS

1. A video receiver apparatus, comprising:

an A0 compliant interface, connected in serial or parallel format to first and second

5 SAR (Segmentation and Reassembly) controllers; and

wherein said first SAR controller handles network protocol data transfers, and

wherein said second SAR controller receives multiple real-time video and other  
data inputs, and

a decoder, connected to the output of said second SAR controller, for decoding said  
10 video and other data inputs.

2. The video receiver of claim 1, further comprising:

an ADSL (Asymmetric Digital Subscriber Line ) modem Network Interface Module  
(NIM) within said A0 interface,

15 wherein said ADSL modem NIM is mechanically mounted inside of said video  
receiver.

3. The video receiver of claim 1, further comprising:

a plurality of Universal Serial Bus (USB) ports compatible with the USB peripheral  
20 bus standard,

wherein said USB ports are contained within said video receiver.

4. The video receiver of claim 1, further comprising:  
an External Reader, for reading input signals from an external security device,  
wherein said External Reader is attached to said video receiver.
5. The external security device of claim 4,  
wherein said external security device is an iButton housing a computer chip,  
and  
wherein said computer chip contains security information for access control  
and electronic transactions.
6. The video receiver of claim 1, further comprising:  
an internal dedicated infrared (I/R) processor, for interpreting commands from external  
I/R devices,  
wherein said dedicated I/R processor having the capability to convert said  
commands from said external I/R devices into keyboard commands.
7. The video receiver of claim 1, further comprising:  
a Web browser program,  
wherein applications within said Web browser program are configured to  
trigger video control functions using DSM-CC (Digital Storage Media - Control Commands)  
on top of CORBA (Common Object Request Broker Architecture).

8. The video receiver of claim 1, further comprising:  
an IrDA (Infrared Data Association) port, compatible with IrDA infrared based  
communications protocol and hardware,  
wherein said IrDA port enabling wireless communication between said video  
5 receiver and an external device.

9. The external device of claim 8,  
wherein said external device is a laptop computer.

10 10. The external device of claim 8,  
wherein said external device is a palmtop computer.

11. The external device of claim 8,  
wherein said external device is a printer.

15

12. The video receiver of claim 1, further comprising:  
a plurality of karaoke jacks, for receiving sound inputs,  
wherein said sound inputs can be mixed, and  
wherein said sound inputs can be enhanced with special effects.

20

13. The video receiver of claim 1, further comprising:  
a Smart Card Reader, for reading input signals from an external Smart Card device,  
wherein said Smart Card Reader is contained within said video receiver.

14. The video receiver of claim 1, further comprising:

a CE (Consumer Electronics)-BUS interface, for supporting the CE-BUS industry standard for power communications, and

wherein said CE-BUS interface within said video receiver enables the control  
5 of household electronics and energy management.

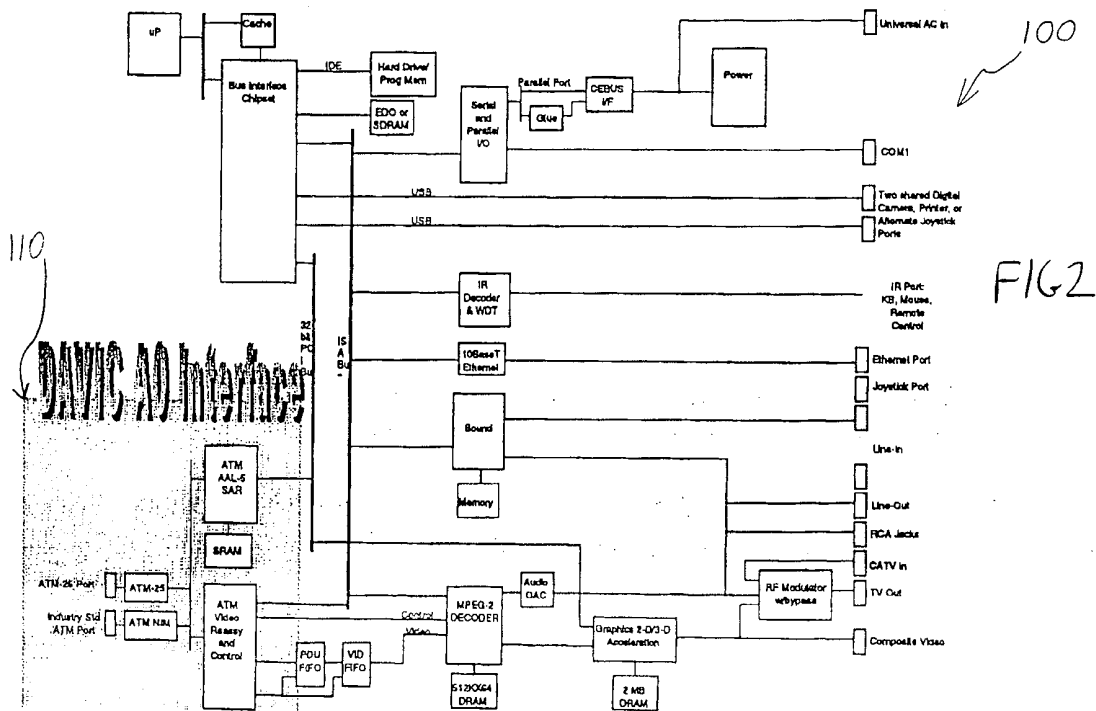
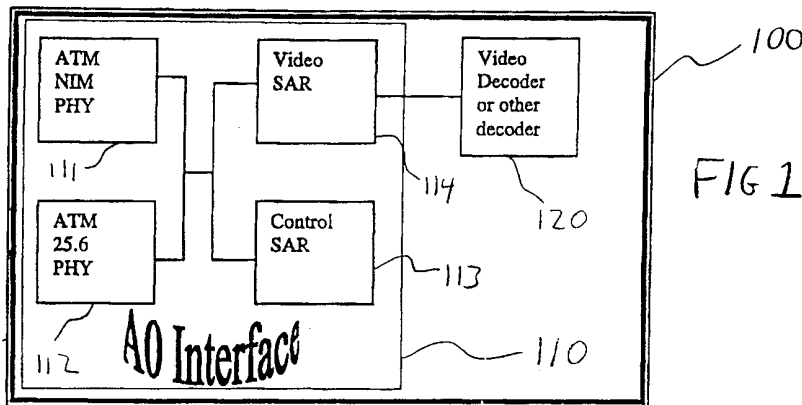

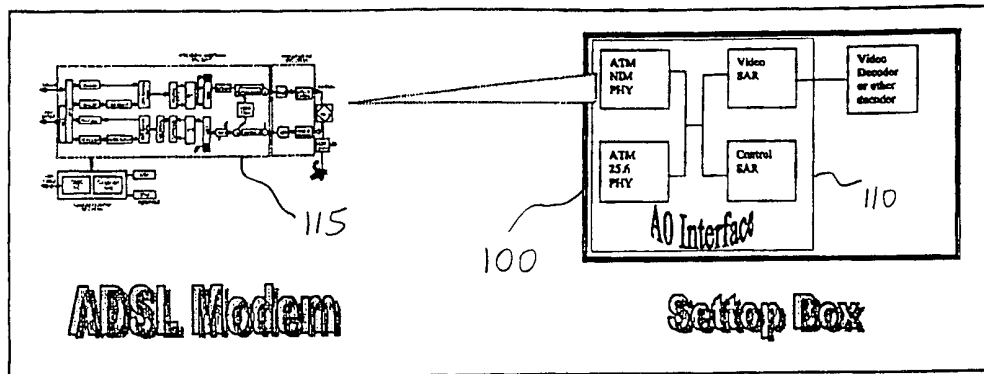

FIG 3

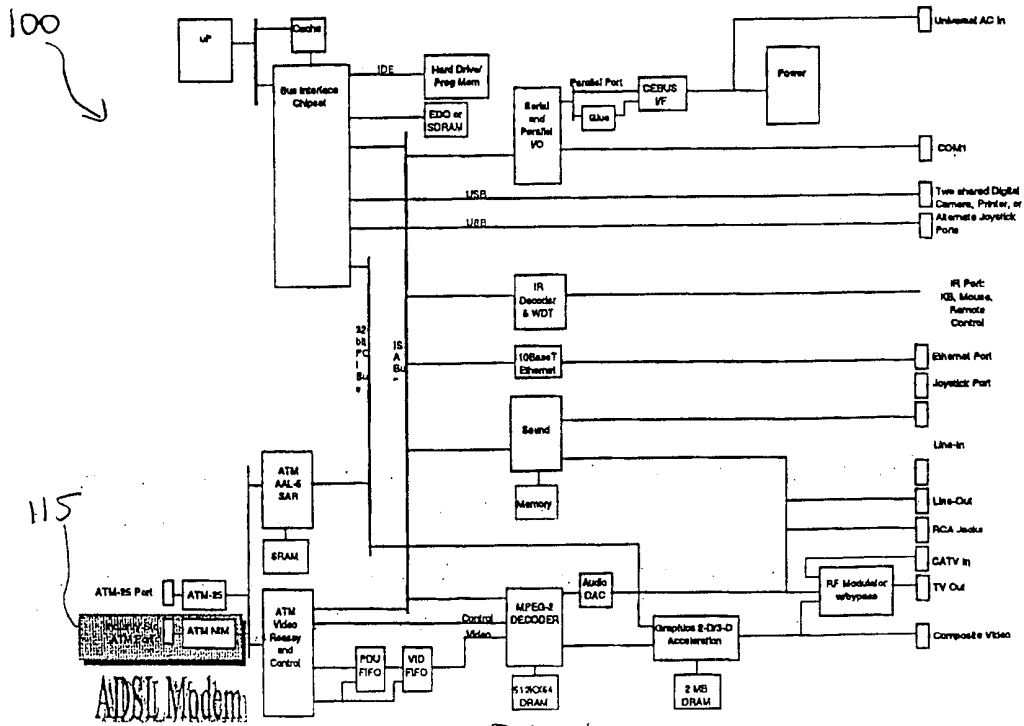

FIG 4



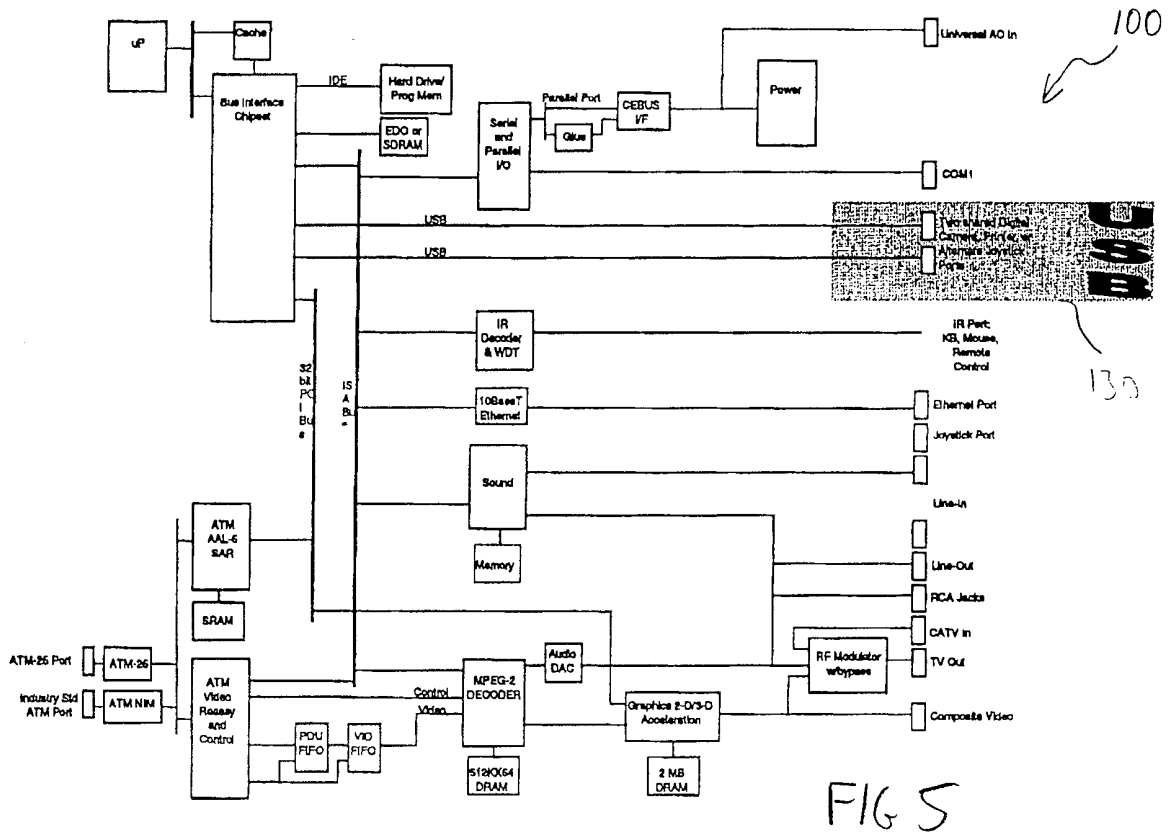
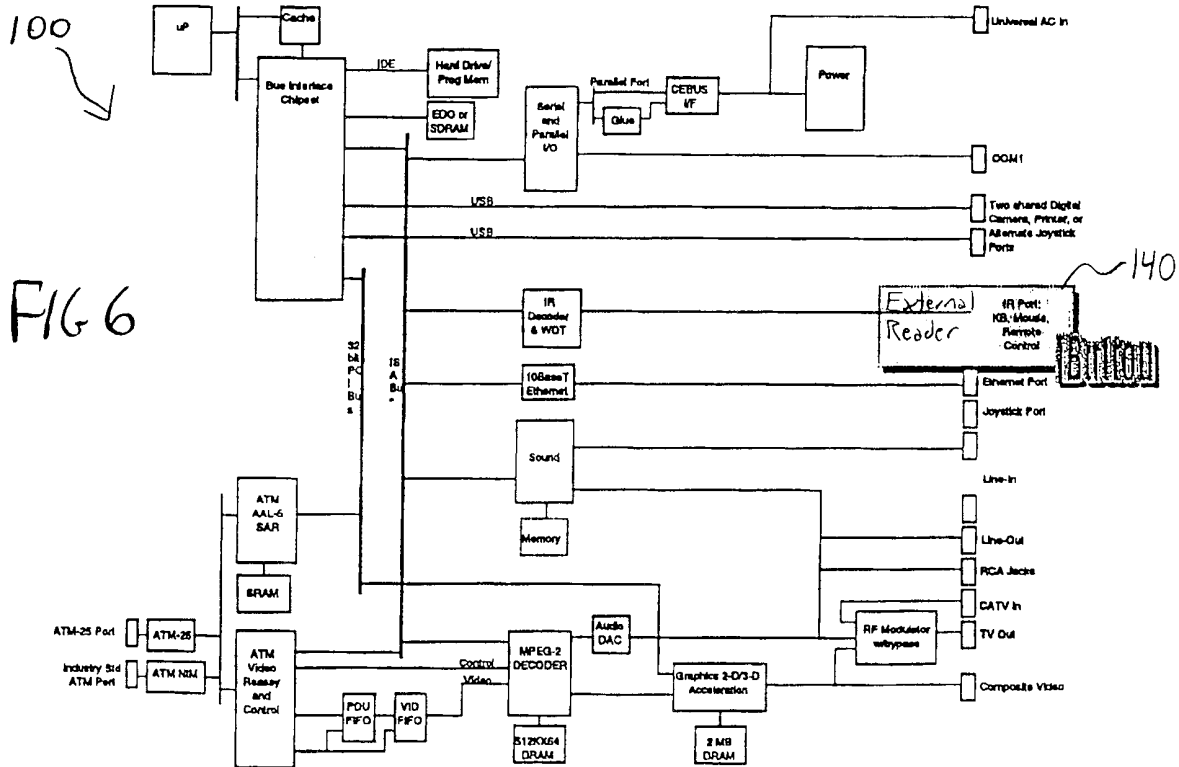
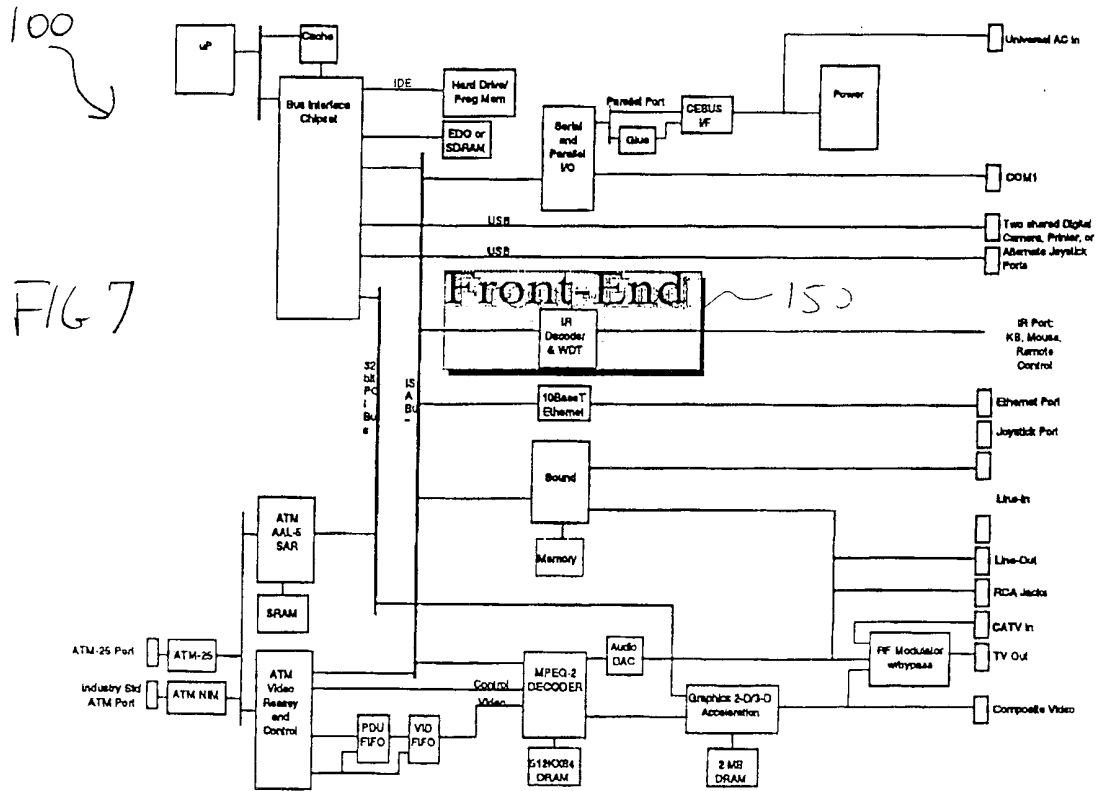

FIG 5





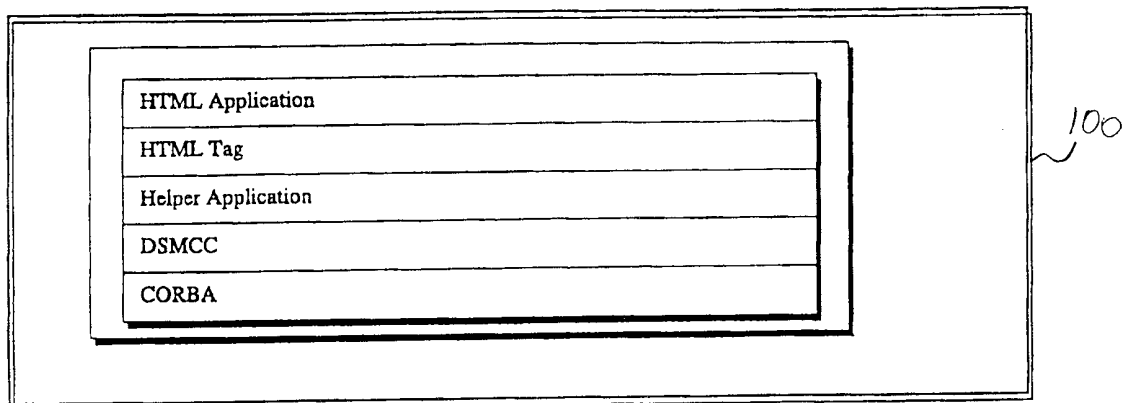

FIG 8

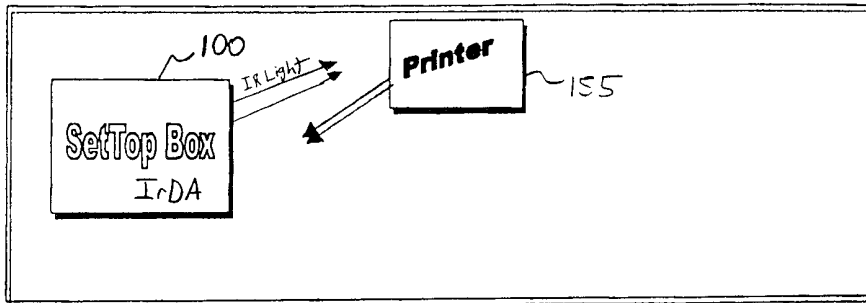

FIG 9

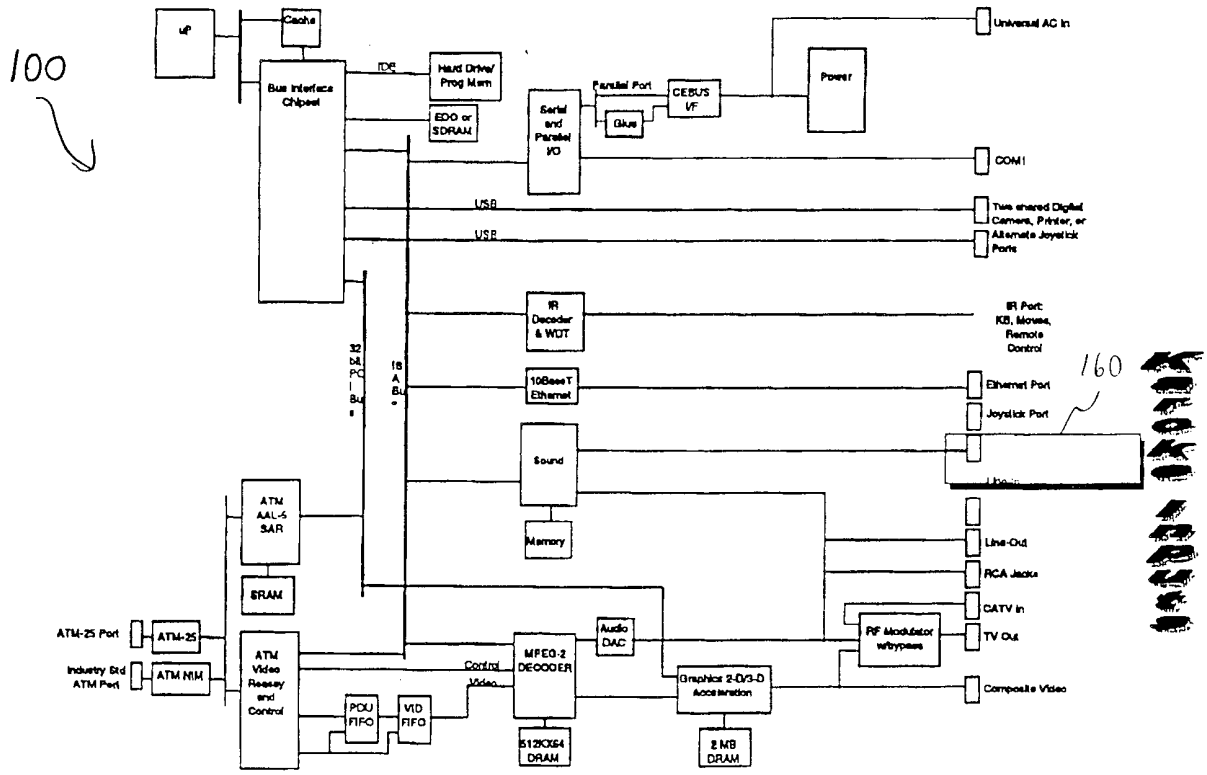

FIG 10

9/10

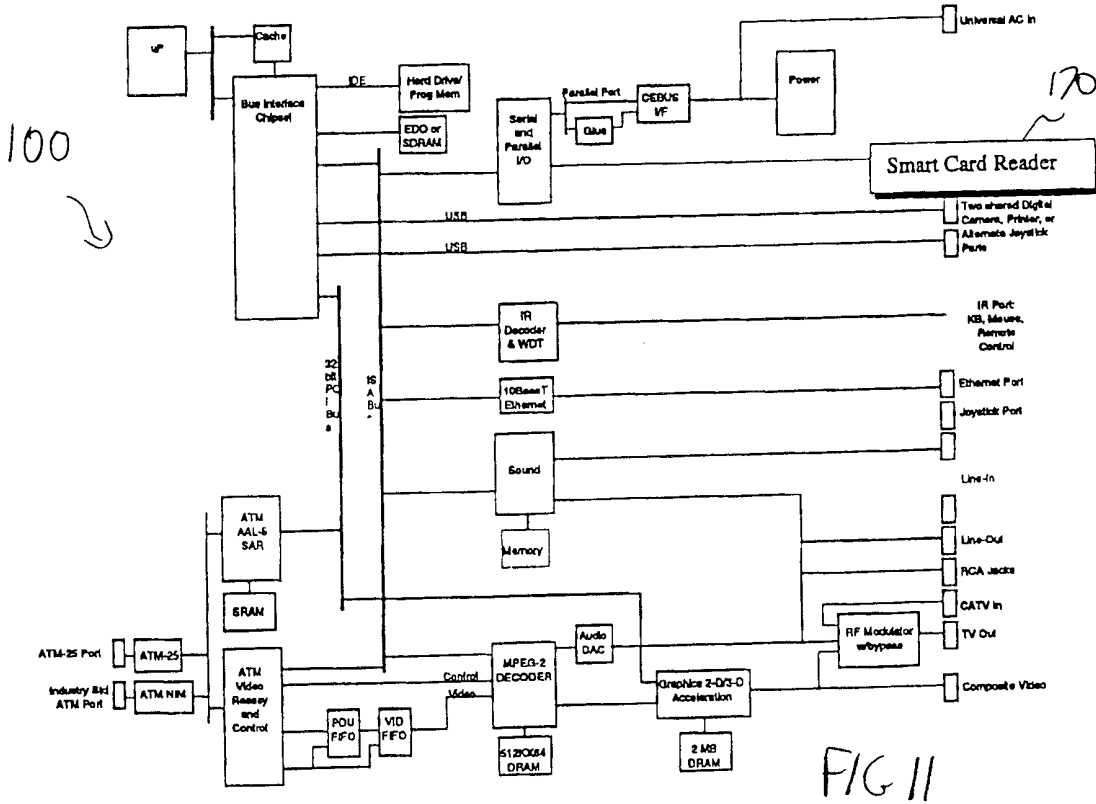

FIG 11

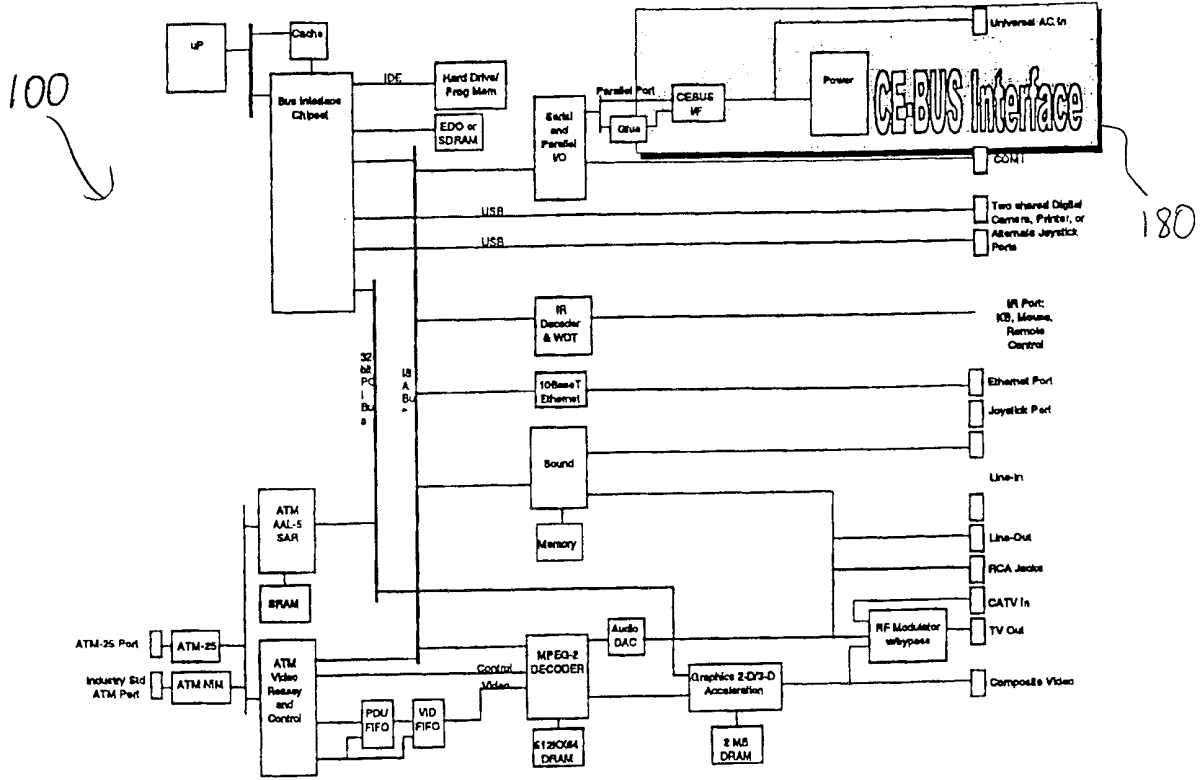

FIG 12



INTERNATIONAL SEARCH REPORT

International application No.  
PCT/US99/17435

**A. CLASSIFICATION OF SUBJECT MATTER**  
 IPC(6) :H04H 1/02; H04N 7/14  
 US CL :709/217; 348/8, 10, 12, 13; 455/ 5.1, 6.2, 6.3  
 According to International Patent Classification (IPC) or to both national classification and IPC

**B. FIELDS SEARCHED**

Minimum documentation searched (classification system followed by classification symbols)  
 U.S. : 709/217, 218, 219; 348/6, 8, 10, 12, 13; 455/ 3.1, 4.1, 5.1, 6.1, 6.2, 6.3

Documentation searched other than minimum documentation to the extent that such documents are included in the fields searched

Electronic data base consulted during the international search (name of data base and, where practicable, search terms used)

**C. DOCUMENTS CONSIDERED TO BE RELEVANT**

Category*	Citation of document, with indication, where appropriate, of the relevant passages	Relevant to claim No.
Y	US 5,488,412 A (MAJETI et al) 30 January 1996, see whole document.	1-7, 12
Y	US 5,512,935 A (MAJETI et al) 30 April 1996, see whole document.	1-7, 12
Y	US 5,740,075 A (BIGHAM et al) 14 April 1998, see whole document.	1-7, 12
Y	US 5,761,606 A (WOLZIEN) 02 June 1998, see whole document.	1-7, 12
Y	US 5,748,493 A (LIGHTFOOT et al) 05 May 1998, see whole document.	2

Further documents are listed in the continuation of Box C.  See patent family annex.

* Special categories of cited documents:	*T* later document published after the international filing date or priority date and not in conflict with the application but cited to understand the principle or theory underlying the invention
*A* document defining the general state of the art which is not considered to be of particular relevance	*X* document of particular relevance; the claimed invention cannot be considered novel or cannot be considered to involve an inventive step when the document is taken alone
*E* earlier document published on or after the international filing date	*Y* document of particular relevance; the claimed invention cannot be considered to involve an inventive step when the document is combined with one or more other such documents, such combination being obvious to a person skilled in the art
*L* document which may throw doubts on priority claim(s) or which is cited to establish the publication date of another citation or other special reason (as specified)	*Z* document member of the same patent family
*O* document referring to an oral disclosure, use, exhibition or other means	
*P* document published prior to the international filing date but later than the priority date claimed	

Date of the actual completion of the international search 08 SEPTEMBER 1999	Date of mailing of the international search report 25 OCT 1999
--	---

Name and mailing address of the ISA/US Commissioner of Patents and Trademarks Box PCT Washington, D.C. 20231 Facsimile No. (703) 305-3230	Authorized officer JOHN W. MILLER <i>James R. Matthews</i> Telephone No. (703) 308-0000
---	---

## INTERNATIONAL SEARCH REPORT

International application No.  
PCT/US99/17435

C (Continuation). DOCUMENTS CONSIDERED TO BE RELEVANT		
Category*	Citation of document, with indication, where appropriate, of the relevant passages	Relevant to claim No.
Y	US 5,768,539 A (METZ et al) 16 June 1998, see whole document.	2
Y	US 5,285,278 A (HOLMAN) 08 February 1994, see whole document.	8-11, 13
Y	US 5,661,517 A (BUDOW et al) 26 August 1997, see whole document.	13
Y	US 5,500,794 A (FUJITA et al) 19 March 1996, see whole document.	14