

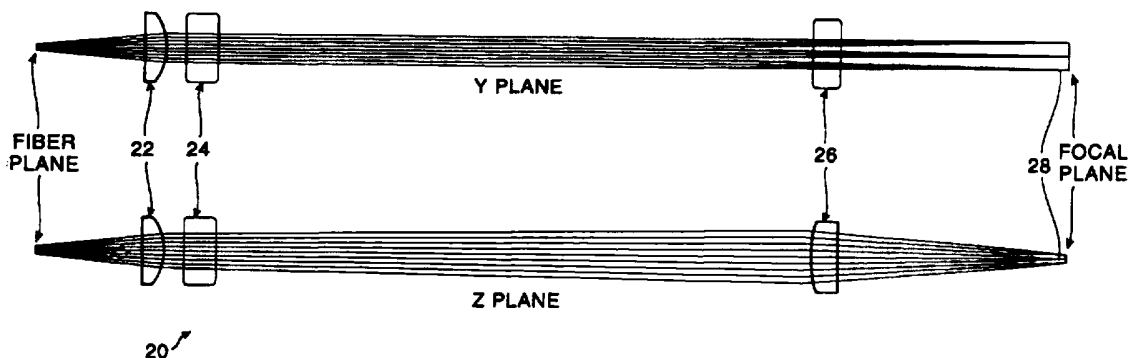

INTERNATIONAL APPLICATION PUBLISHED UNDER THE PATENT COOPERATION TREATY (PCT)

<p>(51) International Patent Classification⁶ : A61N 5/06</p>	<p>A1</p>	<p>(11) International Publication Number: WO 96/22813 (43) International Publication Date: 1 August 1996 (01.08.96)</p>
<p>(21) International Application Number: PCT/US95/16578 (22) International Filing Date: 21 December 1995 (21.12.95) (30) Priority Data: 08/379,776 27 January 1995 (27.01.95) US (71) Applicant: CANDELA LASER CORPORATION [US/US]; 530 Boston Post Road, Wayland, MA 01778 (US). (72) Inventors: HSIA, James, C.; 7 Apache Avenue, Andover, MA 01810 (US). SCHLIER, Robert; 214 Peter Spring Road, Concord, MA 01742 (US). (74) Agent: CAPRARO, Joseph; Testa, Hurwitz & Thibault, High Street Tower, 125 High Street, Boston, MA 02110 (US).</p>		<p>(81) Designated States: AU, CA, JP, European patent (AT, BE, CH, DE, DK, ES, FR, GB, GR, IE, IT, LU, MC, NL, PT, SE). Published <i>With international search report. Before the expiration of the time limit for amending the claims and to be republished in the event of the receipt of amendments.</i></p>

(54) Title: METHOD FOR TREATING PIGMENTATION ABNORMALITIES USING PULSED LASER RADIATION WITH AN ELONGATED CROSS SECTION AND APPARATUS FOR PROVIDING SAME



(57) Abstract

A method for treating pigmentation abnormalities in human skin involves the use of a beam of laser radiation having an elongated cross-sectional area. The beam of pulsed laser radiation having an elongated cross section is produced using a pulsed laser and a delivery system. An elongated area on the skin including a pigmentation abnormality is irradiated with the laser beam. The laser pulse parameters are tailored to the specific type of pigmentation abnormality (e.g., vascular lesions or tattoos) being treated. The beam may have a cross-sectional area characterized by an aspect ratio of greater than two. Also, the beam may have an elliptical cross-sectional area.

FOR THE PURPOSES OF INFORMATION ONLY

Codes used to identify States party to the PCT on the front pages of pamphlets publishing international applications under the PCT.

AM	Armenia	GB	United Kingdom	MW	Malawi
AT	Austria	GE	Georgia	MX	Mexico
AU	Australia	GN	Guinea	NE	Niger
BB	Barbados	GR	Greece	NL	Netherlands
BE	Belgium	HU	Hungary	NO	Norway
BF	Burkina Faso	IE	Ireland	NZ	New Zealand
BG	Bulgaria	IT	Italy	PL	Poland
BJ	Benin	JP	Japan	PT	Portugal
BR	Brazil	KE	Kenya	RO	Romania
BY	Belarus	KG	Kyrgyzstan	RU	Russian Federation
CA	Canada	KP	Democratic People's Republic of Korea	SD	Sudan
CF	Central African Republic	KR	Republic of Korea	SE	Sweden
CG	Congo	KZ	Kazakhstan	SG	Singapore
CH	Switzerland	LI	Liechtenstein	SI	Slovenia
CI	Côte d'Ivoire	LK	Sri Lanka	SK	Slovakia
CM	Cameroon	LR	Liberia	SN	Senegal
CN	China	LT	Lithuania	SZ	Swaziland
CS	Czechoslovakia	LU	Luxembourg	TD	Chad
CZ	Czech Republic	LV	Latvia	TG	Togo
DE	Germany	MC	Monaco	TJ	Tajikistan
DK	Denmark	MD	Republic of Moldova	TT	Trinidad and Tobago
EE	Estonia	MG	Madagascar	UA	Ukraine
ES	Spain	ML	Mali	UG	Uganda
FI	Finland	MN	Mongolia	US	United States of America
FR	France	MR	Mauritania	UZ	Uzbekistan
GA	Gabon			VN	Viet Nam

**METHOD FOR TREATING PIGMENTATION ABNORMALITIES
USING PULSED LASER RADIATION WITH AN ELONGATED
CROSS-SECTION AND APPARATUS FOR PROVIDING SAME**

Field of the Invention

This invention relates generally to the treatment of pigmentation abnormalities using lasers. In particular, the invention relates to a method for treating pigmentation abnormalities in human skin using a beam of pulsed laser radiation having an elongated cross-section and an apparatus for providing such beam.

5 Background

Abnormal pigmentation of the skin is commonly seen in dermatologic practice. A subject's skin may have pigmentation abnormalities due to vascular lesions, pigmented lesions, or tattoos. Vascular lesions, such as port wine stain birthmarks, telangiectasia and hemangiomas, are characterized by abnormally enlarged blood vessels. Pigmented
10 lesions are non-vascular disfigurements of the skin caused by an abnormally high concentration of melanin in localized areas of the skin. Such pigmented lesions include freckles, age or liver spots, cafe' au lait birthmarks, lentigines, nevi, melanomes, nevus of Ota and lentigo maligna. Tattoos may be divided into two categories, including self-inflicted tattoos and traumatic tattoos. Traumatic tattoos are created during an
15 accident which causes a scrape or abrasion such that a foreign material becomes imbedded in the skin.

Pulsed laser systems, such as those manufactured by Candela Laser Corporation, have been widely used by plastic surgeons and dermatologists to successfully treat pigmentation abnormalities on the face and other areas of the human body for obvious
20 cosmetic reasons. For example, Candela's Pigmented Lesion Laser has been used to lighten or remove pigmented lesions. Candela's TATULAZR has been used to remove blue/black tattoos. Candela's Vascular Lesion Laser has been used to lighten or remove vascular lesions.

-2-

These and other such laser systems typically include a pulsed laser and a delivery system. The delivery system includes a handpiece that delivers pulses of laser radiation to a subject's skin typically having a circular cross-section ranging from 1-10 mm in spot diameter. The treatment procedure generally involves irradiating an area of a subject's skin including a pigmentation abnormality with a beam of pulsed laser radiation.

Undesirable side effects of laser treatment include purpura, hypopigmentation and hyperpigmentation. Purpura is generally attributed to the damage to the skin's microvasculature which results in the treated area of the subject's skin turning blue/black in appearance. Purpura can take up to two weeks to clear and is particularly bothersome when the treated area is on a subject's face. Hyperpigmentation can be caused by the deposition of hemosiderin, a blood breakdown by-product in the skin, which occurs due to damage to the blood vessels. This can result in the treated area of the subject's skin turning brown some days after the treatment and is particularly common when the vessels treated are on the legs. Hyperpigmentation is slow to clear, sometimes taking up to a year to go away. Hypopigmentation is attributable to damage to the melanin-producing cell in the skin. Hypopigmentation is generally transient, but is cosmetically undesirable while it persists.

In treating a pigmentation abnormality which is distinct and clearly demarcated, it is advantageous to irradiate the area of the skin including the abnormality while minimizing exposure of the adjacent normally pigmented tissue to radiation. This results in reduced purpura, hypopigmentation and hyperpigmentation. One technique used involves manipulating the handpiece to trace out or scan the area of the skin including the pigmentation abnormality with the laser pulses having a circular cross-sectional area or spot. In cases where the pigmentation abnormality is elongated in shape, to minimize the exposure of adjacent normally pigmented skin, a pulsed beam with a smaller cross-sectional area is used on the area of the skin including the abnormality. It has been found clinically that using pulses with a small cross-sectional area (spot diameter of 3 mm or less) results in much less purpura and reduced incidence of hypopigmentation and hyperpigmentation.

One problem with this technique, however, is that treatment is quite tedious, since only a small portion of the targeted pigmentation abnormality is irradiated for each laser

-3-

pulse. Thus, the number of pulses required to treat a pigmentation abnormality and the treatment time increase significantly.

Summary of the Invention

The present invention features a method for treating pigmentation abnormalities in human skin using a beam of pulsed laser radiation having an elongated cross-sectional area. A beam of pulsed laser radiation having an elongated cross-sectional area is produced using a pulsed laser and a delivery system. An elongated area on the skin including a pigmentation abnormality is irradiated with pulses of laser radiation from the beam. As such, large sections of the abnormality may be irradiated with minimal exposure to adjacent normally pigmented tissue.

The laser pulse parameters are tailored to the specific type of pigmentation abnormality being treated. For treatment of vascular lesions a beam of, laser pulses of at least one hundred microseconds in duration and one-tenth joule are provided by the laser. For treatment of tattoos, a beam of laser pulses of less than five hundred nanoseconds in duration and of at least one-tenth joule are provided by the laser. In one embodiment, the laser beam has a cross-sectional area characterized by an aspect ratio of greater than two. In another embodiment, the laser beam has an elliptical cross-sectional area. The elliptical beam may have a major axis of between about 5-15 mm in length and a minor axis of between about 1-3 mm in length.

The invention also features an apparatus for use with a dermatology laser to treat pigmentation abnormalities in human skin. The apparatus includes a handpiece and a fiber. The fiber connects to the laser for providing a beam of pulsed of laser radiation therefrom. The handpiece, in which the beam of pulsed laser radiation provided by the fiber are converted into an output beam of pulsed laser radiation having an elongated cross-sectional area, is coupled to the fiber. The handpiece is holdable by a user to irradiate an elongated area of the subject's skin including the pigmentation abnormality with pulses of laser radiation from the output beam.

The invention offers numerous advantages over existing dermatologic procedures and devices. One advantage is that larger sections of the pigmentation abnormality can be irradiated, thereby reducing both the number of pulses required to treat the abnormality

-4-

and the treatment time. Another advantage is that the invention is energy efficient. That is, for a given amount of laser pulse energy, a longer section of the pigmentation abnormality is treated because much less of the energy is wasted on normally pigmented tissue. Another advantage is exposure to adjacent normally pigmented tissue is reduced, resulting in less purpura, hypopigmentation and hyperpigmentation. Yet another advantage of the invention is that a pigmentation abnormality is more effectively destroyed because longer sections of the abnormality are treated in a single pulse. It has been found clinically that when a large circular diameter beam is used to treat a pigmentation abnormality, the pigmentation abnormality is more effectively cleared than when a small circular beam is used at the same fluence. The use of an elongated beam gives the effectiveness of a large circular beam, while minimizing exposure to adjacent normally pigmented tissue.

Brief Description of the Drawings

The foregoing and other objects, features and advantages of the invention will become apparent from the following more particular description of preferred embodiments of the invention, as illustrated in the accompanying drawings. The drawings are not necessarily to scale, emphasis instead being placed on illustrating the principles of the present invention.

Fig. 1 is an illustration of an apparatus including a laser and a delivery system for practicing the invention.

Fig. 2 is an enlarged perspective view of a delivery system incorporating the principles of the invention.

Fig. 3 is an illustration of an optical system useable in the delivery system of Fig. 2.

Fig. 4 is an illustration of a pigmentation abnormality exposed to a plurality of laser pulses from a beam having an elongated cross-sectional area.

Detailed Description

Fig. 1 is an illustration of a flashlamp pumped tunable dye laser system 10 for practicing the invention. The system includes a dye laser 12 and a delivery system 13. While a dye laser is described herein, any other suitable pulsed laser may be used without departing from the scope of the invention. A beam of pulsed laser radiation generated by

-5-

the laser are directed to a target area of a subject's skin including a pigmentation abnormality via the delivery system.

Fig. 2 is an enlarged perspective view of a delivery system incorporating the principles of the invention. The delivery system 13 includes a fiber 14 having a circular cross-section and a handpiece 16. A beam of pulsed laser radiation having a circular cross-section are delivered by the fiber to the handpiece. In accordance with the invention, the beam of laser pulses is converted by the delivery system into a pulsed output beam of laser radiation having an elongated cross-sectional area. To accomplish this, the handpiece may comprise an optical system 20 (Fig. 3) which performs the conversion process. The optical system projects the output beam to an elongated spot adjacent the end of a positioning extension 18. A user holding the handpiece irradiates an elongated area of the subject's skin including the pigmentation abnormality with output pulses from the beam.

Fig 3. is a representative optical system 20 useable in the handpiece shown in two planes (i.e., the Y and Z planes). As shown, the system includes a plano convex spherical lens 22 and two plane convex cylindrical lenses 24, 26 of focal lengths f_1 , f_2 , f_3 respectively. The Y and Z planes are two mutually perpendicular planes, both perpendicular to the optic axis. The lens 24 is arranged so that its axis of curvature is located in the Z plane, and the lens 26 is arranged so that its axis of curvature is in the Y plane. The lens 22 collimates pulsed laser radiation delivered by the fiber into a cylindrically symmetric pulsed output beam 28. The lens 24 focuses the beam in the Y plane onto the focal plane and has no effect in the Z plane. Conversely, the lens 26 focuses the beam in the Z plane onto the focal plane and has no effect in the Y plane. The optical system shown converts a pulsed input beam from a fiber with a circular cross-section into a pulsed output beam having an elliptical cross-section with a major axis of about 5-15 mm in length and a minor axis of about 1-3 mm in length.

While an optical system comprising three lenses has been described, it is noted that other optical elements may be used without departing from the scope of the invention. For example, the optical system may include two orthogonal cylindrical lenses, highly astigmatic lenses, tilted spherical lenses, anamorphic prisms, or multifaceted prisms. Alternatively, laser pulses may be directly converted by the fiber into output pulses having

-6-

an elongated cross-section. To accomplish this, the fiber or at least that portion of the fiber disposed in the handpiece has an elongated cross-section. The fiber may have an elliptical cross-section characterized by a ratio of major axis/minor axis, or aspect ratio, or more than two.

5 Fig. 4 illustrates the treatment of a pigmentation abnormality 30 in accordance with the invention. The pigmentation abnormality shown may be a vascular lesion or a tattoo. Accordingly, the laser parameters are tailored to the type of pigmentation abnormality being treated. Laser pulses of at least one hundred microseconds in duration and one-tenth joule are provided by the laser to treat vascular lesions. Laser pulses of less
10 than five hundred nanoseconds in duration and of at least one-tenth joule are provided to treat tattoos.

 Laser pulses having an elongated cross-section are produced using the laser and delivery system shown in Fig. 1. The laser pulses may have a cross-sectional area characterized by an aspect ratio of greater than two. Further, the pulses may have an
15 elliptical cross-section. Such elliptical spot has a major axis of between about 5-15 mm in length and a minor axis of between about 1-3 mm in length. In any case, an elongated area 32 on the subject's skin including a portion of the pigmentation abnormality is irradiated with laser pulses exiting from the handpiece. The process is repeated for other elongated areas 34, 36 and continues until the entire abnormality has been irradiated. For
20 each area of the subject's skin, the laser pulses are aligned with an elongated portion of the pigmentation abnormality such that large sections of the abnormality are irradiated with minimal exposure to adjacent normally pigmented tissue.

 Treatment of pigmentation abnormalities using the method and apparatus of the invention: (1) reduces the number of pulses required to treat the abnormality and the
25 treatment time, (2) is energy efficient in that for a given amount of pulse energy, a longer section of the pigmentation abnormality and proportionately smaller section of normally pigmented tissue are treated, (3) reduces purpura, hypopigmentation and hyperpigmentation by minimizing exposure to adjacent normally pigmented tissue, and (4)
30 more effectively destroys pigmentation abnormalities because longer sections of the abnormality are treated with a single pulse.

Equivalents

While the invention has been particularly shown and described with reference to specific preferred embodiments, it should be understood by those skilled in the art that various changes in form and detail may be made therein without departing from the spirit
5 and scope of the invention as defined by the appended claims.

-8-

Claims

- 1 1. A method of treating a pigmentation abnormality in human skin comprising:
2 producing a beam of pulsed of laser radiation having an elongated cross-
3 sectional area using a pulsed laser and a delivery system;
4 irradiating an elongated area on the skin including the pigmentation
5 abnormality with the beam of pulsed of laser radiation.
- 1 2. The method of claim 1 further comprising producing a beam of pulsed laser
2 radiation having an aspect ratio of greater than two.
- 1 3. The method of claim 1 further comprising producing a beam of pulsed laser
2 radiation having an elliptical cross-sectional area.
- 1 4. The method of claim 1 wherein the beam of pulsed laser radiation has an elliptical
2 cross-sectional area with a major axis of between about 5-15 mm in length and a minor
3 axis of between about 1-3 mm in length.
- 1 5. The method of claim 1 wherein the delivery system comprises at least one lens or
2 prism for producing a beam of pulsed laser radiation having an elongated cross-sectional
3 area.
- 1 6. The method of claim 1 wherein the delivery system comprises a fiber with an
2 elongated cross-section for producing a beam of pulsed of laser radiation having an
3 elongated cross-sectional area.
- 1 7. The method of claim 1 further comprising producing a beam of pulsed laser
2 radiation of at least one-tenth joule in energy.
- 1 8. The method of claim 1 wherein the pigmentation abnormality is a vascular lesion
2 or a tattoo.
- 1 9. A method of treating a vascular lesion in human skin comprising:
2 producing a beam of pulsed laser radiation of at least one hundred
3 microseconds in duration and at least one-tenth joule in energy using a pulsed laser and

-9-

4 delivery system, the beam of pulsed laser radiation having an elongated cross-sectional
5 area and an aspect ratio greater than two;
6 irradiating an elongated area of the skin that includes the vascular lesion
7 with the pulsed beam of laser radiation.

1 10. The method of claim 9 further comprising producing a beam of pulsed laser
2 radiation having an elliptical cross-sectional area.

1 11. The method of claim 9 wherein the beam of pulsed of laser radiation has an
2 elliptical cross-sectional area with a major axis of about 5-15 mm in length and a minor
3 axis of about 1-3 mm in length.

1 12. A method of treating a tattoo in human skin comprising:
2 producing a beam of pulsed laser radiation less than five hundred
3 nanoseconds in duration and at least one-tenth joule in energy using a pulsed laser and
4 delivery system, the beam of pulsed laser radiation having an elongated cross-sectional
5 area and an aspect ratio greater than two;
6 irradiating an elongated area of the skin that includes the tattoo with the
7 pulsed laser radiation.

1 13. The method of claim 12 further comprising producing the beam of pulsed laser
2 radiation having an elliptical cross-sectional area.

1 14. The method of claim 12 wherein the the beam of pulsed of laser radiation has an
2 elliptical cross-sectional area with a major axis of about 5-15 mm in length and a minor
3 axis of about 1-3 mm in length.

1 15. A delivery system for use with a dermatology laser to treat a pigmentation
2 abnormality in human skin comprising:
3 a fiber providing a beam of pulsed of laser radiation from the laser;
4 a handpiece in which the beam of pulsed laser radiation provided by the fiber are
5 converted into an output beam having an elongated cross-sectional area and an aspect
6 ratio greater than two, the handpiece holdable by a user to irradiate an elongated area of
7 the skin including the pigmentation abnormality with the output.

1 16. The delivery system of claim 15 wherein the output beam has an elliptical cross-
2 sectional area.

1 17. The delivery system of claim 15 wherein the output beam has an elliptical cross-
2 sectional area with a major axis of between about 5-10 mm in length and a minor axis of
3 between about 1-3 mm in length.

1 18. The delivery system of claim 15 wherein the handpiece comprises at least one lens
2 for converting the beam of pulsed laser radiation into an output beam.

1 19. The delivery system of claim 15 wherein the handpiece comprises at least one
2 prism for converting the beam of pulsed laser radiation into an output beam.

1 20. The delivery system of claim 15 wherein the fiber has an elongated cross-section
2 for converting the beam of pulsed laser radiation into an output beam.

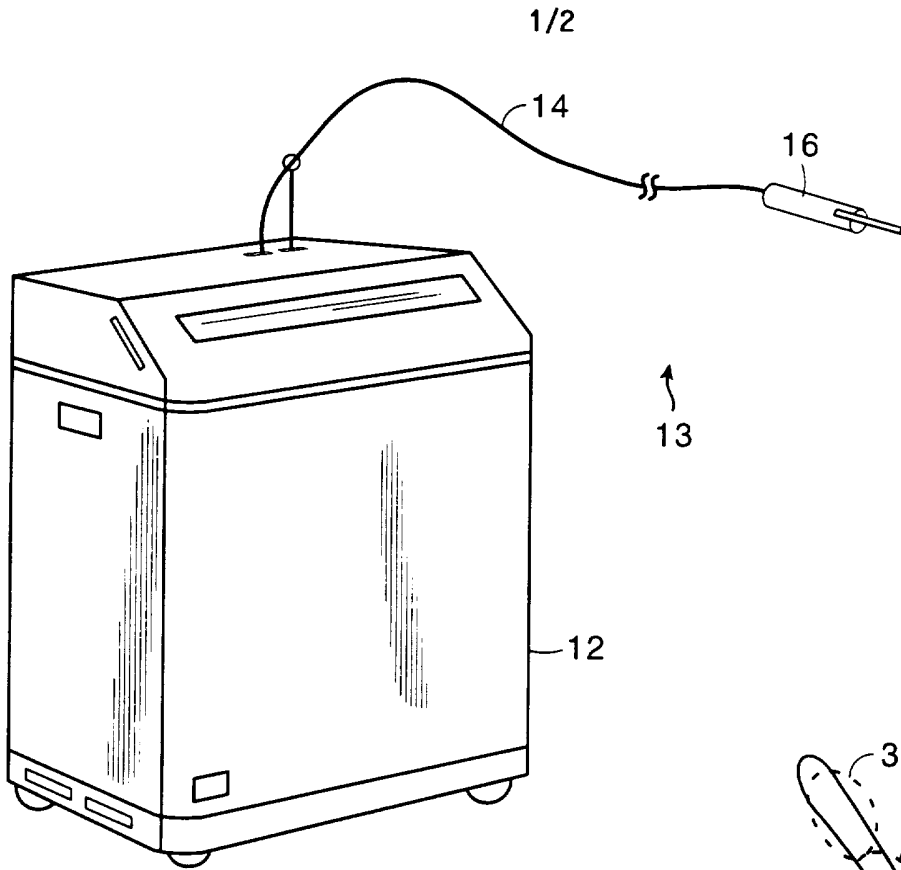

FIG. 1

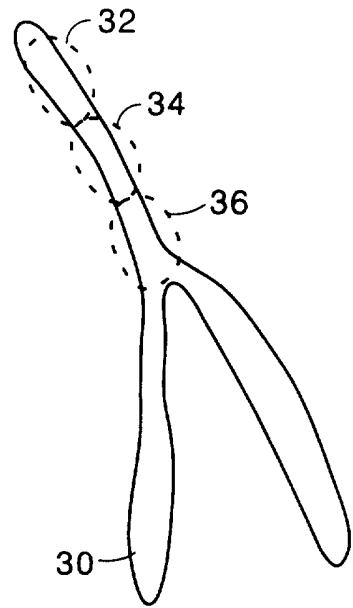

FIG. 4

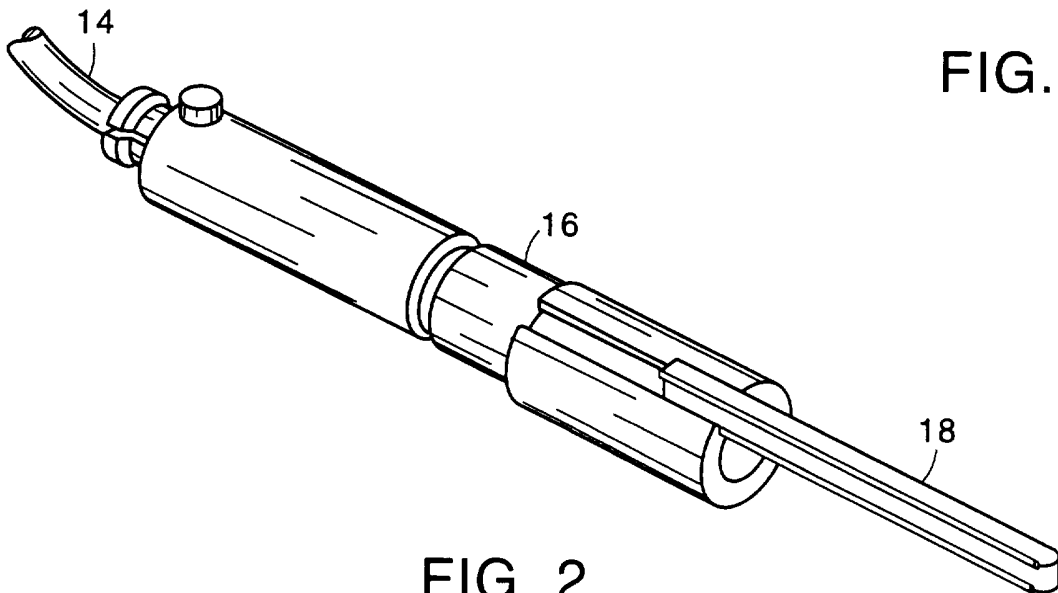

FIG. 2
SUBSTITUTE SHEET (RULE 26)

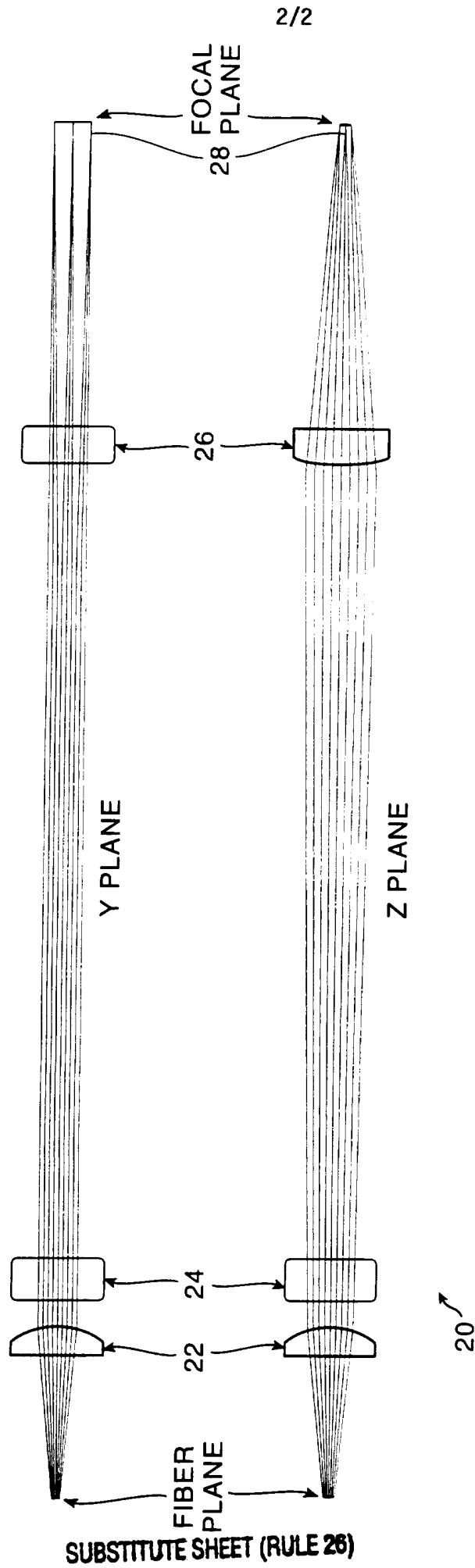

FIG. 3

INTERNATIONAL SEARCH REPORT

International Application No
PCT/US 95/16578

A. CLASSIFICATION OF SUBJECT MATTER
IPC 6 A61N5/06

According to International Patent Classification (IPC) or to both national classification and IPC

B. FIELDS SEARCHED

Minimum documentation searched (classification system followed by classification symbols)
IPC 6 A61N A61B

Documentation searched other than minimum documentation to the extent that such documents are included in the fields searched

Electronic data base consulted during the international search (name of data base and, where practical, search terms used)

C. DOCUMENTS CONSIDERED TO BE RELEVANT

Category *	Citation of document, with indication, where appropriate, of the relevant passages	Relevant to claim No.
A	DE,A,38 37 248 (TEICHMANN) 3 May 1990 see page 4, line 25 - line 38 ---	15
A	US,A,4 718 416 (NANAUMI) 12 January 1988 see claim 1 ---	15
A	WO,A,91 13652 (CANDELA LASER CORPORATION) 19 September 1991 see claim 1 ---	15
A	WO,A,91 13653 (CANDELA LASER CORPORATION) 19 September 1991 see abstract -----	15

Further documents are listed in the continuation of box C.

Patent family members are listed in annex.

* Special categories of cited documents :

- 'A' document defining the general state of the art which is not considered to be of particular relevance
- 'E' earlier document but published on or after the international filing date
- 'L' document which may throw doubts on priority claim(s) or which is cited to establish the publication date of another citation or other special reason (as specified)
- 'O' document referring to an oral disclosure, use, exhibition or other means
- 'P' document published prior to the international filing date but later than the priority date claimed

- 'T' later document published after the international filing date or priority date and not in conflict with the application but cited to understand the principle or theory underlying the invention
- 'X' document of particular relevance; the claimed invention cannot be considered novel or cannot be considered to involve an inventive step when the document is taken alone
- 'Y' document of particular relevance; the claimed invention cannot be considered to involve an inventive step when the document is combined with one or more other such documents, such combination being obvious to a person skilled in the art.
- '&' document member of the same patent family

Date of the actual completion of the international search

21 May 1996

Date of mailing of the international search report

- 7. 06. 96

Name and mailing address of the ISA

European Patent Office, P.B. 5818 Patentlaan 2
NL - 2280 HV Rijswijk
Tel. (+ 31-70) 340-2040, Tx. 31 651 epo nl,
Fax: (+ 31-70) 340-3016

Authorized officer

Taccoen, J-F

INTERNATIONAL SEARCH REPORT

International application No.

PCT/US 95/ 16578

Box I Observations where certain claims were found unsearchable (Continuation of item 1 of first sheet)

This international search report has not been established in respect of certain claims under Article 17(2)(a) for the following reasons:

1. Claims Nos.: 1 - 14
because they relate to subject matter not required to be searched by this Authority, namely:

Method for treatment of the human or animal body by therapy
(Rule 39.1 (iv) PCT)

2. Claims Nos.:
because they relate to parts of the international application that do not comply with the prescribed requirements to such an extent that no meaningful international search can be carried out, specifically:

3. Claims Nos.:
because they are dependent claims and are not drafted in accordance with the second and third sentences of Rule 6.4(a).

Box II Observations where unity of invention is lacking (Continuation of item 2 of first sheet)

This International Searching Authority found multiple inventions in this international application, as follows:

1. As all required additional search fees were timely paid by the applicant, this international search report covers all searchable claims.
2. As all searchable claims could be searched without effort justifying an additional fee, this Authority did not invite payment of any additional fee.
3. As only some of the required additional search fees were timely paid by the applicant, this international search report covers only those claims for which fees were paid, specifically claims Nos.:
4. No required additional search fees were timely paid by the applicant. Consequently, this international search report is restricted to the invention first mentioned in the claims; it is covered by claims Nos.:

Remark on Protest

- The additional search fees were accompanied by the applicant's protest.
- No protest accompanied the payment of additional search fees.

INTERNATIONAL SEARCH REPORT

Information on patent family members

International Application No

PCT/US 95/16578

Patent document cited in search report	Publication date	Patent family member(s)	Publication date
DE-A-3837248	03-05-90	NONE	
US-A-4718416	12-01-88	JP-A- 60148567	05-08-85
WO-A-9113652	19-09-91	AU-B- 7463991	10-10-91
		AU-B- 7562591	10-10-91
		DE-D- 69103409	15-09-94
		DE-T- 69103409	23-03-95
		EP-A- 0519964	30-12-92
		WO-A- 9113653	19-09-91
		US-A- 5312395	17-05-94
WO-A-9113653	19-09-91	AU-B- 7463991	10-10-91
		AU-B- 7562591	10-10-91
		DE-D- 69103409	15-09-94
		DE-T- 69103409	23-03-95
		EP-A- 0519964	30-12-92
		WO-A- 9113652	19-09-91
		US-A- 5312395	17-05-94