



(51) International Patent Classification:

Not classified

(21) International Application Number:

PCT/US2018/054165

(22) International Filing Date:

03 October 2018 (03.10.2018)

(25) Filing Language:

English

(26) Publication Language:

English

(30) Priority Data:

62/567,802 04 October 2017 (04.10.2017) US

(71) Applicant: SKYWAVE NETWORKS LLC [US/US];
P.O. Box 3642, Chicago, IL 60654 (US).

(72) Inventor: BABICH, Kevin; 2600 Nottingham Drive, Valparaiso, IN 46383 (US).

(74) Agent: SCHMAL, Charles, P. et al.; Woodard, Emhardt, Moriarty, McNett & Henry LLP, 111 Monument Circle, Suite 3700, Indianapolis, IN 46204 (US).

(81) Designated States (unless otherwise indicated, for every kind of national protection available): AE, AG, AL, AM, AO, AT, AU, AZ, BA, BB, BG, BH, BN, BR, BW, BY, BZ, CA, CH, CL, CN, CO, CR, CU, CZ, DE, DJ, DK, DM, DO, DZ, EC, EE, EG, ES, FI, GB, GD, GE, GH, GM, GT, HN, HR, HU, ID, IL, IN, IR, IS, JO, JP, KE, KG, KH, KN, KP,

KR, KW, KZ, LA, LC, LK, LR, LS, LU, LY, MA, MD, ME, MG, MK, MN, MW, MX, MY, MZ, NA, NG, NI, NO, NZ, OM, PA, PE, PG, PH, PL, PT, QA, RO, RS, RU, RW, SA, SC, SD, SE, SG, SK, SL, SM, ST, SV, SY, TH, TJ, TM, TN, TR, TT, TZ, UA, UG, US, UZ, VC, VN, ZA, ZM, ZW.

(84) Designated States (unless otherwise indicated, for every kind of regional protection available): ARIPO (BW, GH, GM, KE, LR, LS, MW, MZ, NA, RW, SD, SL, ST, SZ, TZ, UG, ZM, ZW), Eurasian (AM, AZ, BY, KG, KZ, RU, TJ, TM), European (AL, AT, BE, BG, CH, CY, CZ, DE, DK, EE, ES, FI, FR, GB, GR, HR, HU, IE, IS, IT, LT, LU, LV, MC, MK, MT, NL, NO, PL, PT, RO, RS, SE, SI, SK, SM, TR), OAPI (BF, BJ, CF, CG, CI, CM, GA, GN, GQ, GW, KM, ML, MR, NE, SN, TD, TG).

Declarations under Rule 4.17:

- as to applicant's entitlement to apply for and be granted a patent (Rule 4.17(ii))
- as to the applicant's entitlement to claim the priority of the earlier application (Rule 4.17(iii))

Published:

- without international search report and to be republished upon receipt of that report (Rule 48.2(g))

(54) Title: ADJUSTING TRANSMISSIONS BASED ON DIRECT SENSING OF THE IONOSPHERE

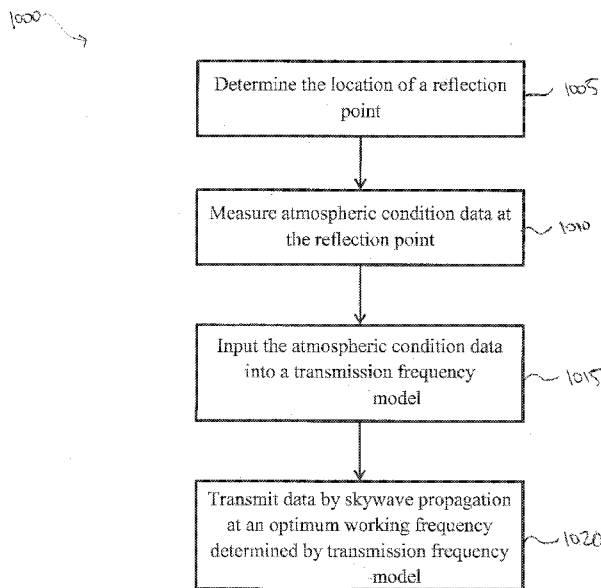
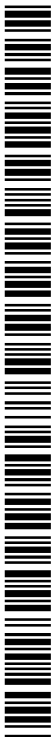

Fig. 10

(57) Abstract: A communication system uses skywave propagation to transmit data between communication nodes over a data transmission path. An atmospheric sensor is configured to collect atmospheric data at the reflection point of the data transmission path where the transmission path is redirected from the atmosphere toward the surface of the Earth. Data collected by the atmospheric sensor may be used to predict future ionospheric conditions and determine optimum working frequencies for transmission of data between the communication nodes.



ADJUSTING TRANSMISSIONS BASED ON DIRECT SENSING OF THE IONOSPHERE

BACKGROUND

5 Skywave propagation of electromagnetic waves allows relatively low-latency
transmission of data over long distances. These electromagnetic waves are initially directed
toward the sky and eventually refracted from a sufficiently ionized portion of the atmosphere,
the ionosphere, to be directed back toward the surface of the Earth. However, the conditions
of the ionosphere are constantly changing due to multiple factors, including the time of day,
10 solar flares, and weather conditions. These changes in the ionosphere can affect the properties
of data transmission by skywave propagation. Public sources of ionosphere data are available,
but these sources may measure ionospheric conditions that are far away from a desired path of
data transmission, and therefore may prove to be inaccurate.

SUMMARY

In some communication systems, an ionosonde network, such as ionosonde data provided by governmental agencies, is used to model the ionosphere. However, the ionosondes in these network systems are not directly pertaining to the specific ionospheric conditions at the reflection points of issue. This current system directly positions the ionosonde as well as other sensors to collect data at the reflection points or other key areas along a data transmission path. In one particular aspect, an ionosonde is positioned directly below one or more of the reflection points for a radio signal. In another example, a weather sensor array can be used to sense the weather conditions such as lightning or other conditions that may detrimentally impact the radio transmission.

Based on the ionosphere conditions and environmental conditions sensed at these various points, this information as well as other information can be used to model and choose when frequencies should be switched as well as help with decoding the signal. In one particular example, an ionosonde is positioned on a ship, balloon, oil rig, or other structure to continually monitor the ionospheric conditions located under a particular reflection point in an ocean. In other variations, the various stations can be used to monitor the digital broadcast signal such as during a broadcasting mode for transmitting music along the path to model the degradation of the signal and frequency along the path. With this data, the system can then predict future ionospheric and other conditions that may detrimentally impact communication. Based on this information, a number of different aspects of the communication circuit can be controlled. For example, this data can be used to pick when to switch to a different channel and which channel to pick as the next one. This information can be also used to encode and/or decode the transmitted signal.

Contingent on a number of factors, such as ionospheric conditions, the optimal or useable frequency to enhance the signal to noise ratio for transmission may vary. For example, the optimal transmission frequency may vary depending on whether the transmission was a two-hop path or a three-hop path. By measuring the ionospheric height and condition along with other measurements, such as signal strength and noise, the transmission frequency can be updated to reduce latency and/or errors. The optimum frequency in one form is selected based at least in part on the ionospheric conditions measured by the ionosonde. Depending on the measurements from one or more ionosondes, the frequency can be switched so as to reduce error and/or reduce latency. Greater arrival angles indicate that the skywave travel path for the signal was over a relatively longer three-hop path rather than the shorter two-hop path. With

the greater length, the three-hop path typically (but not always) experiences greater distortion and/or latency as compared to the two-hop path. The ionosonde can be used to determine how well formed the signal will be when received such that the system can make appropriate adjustments. In one example, based at least in part on ionosonde readings, the system is configured or biased to switch to a path with a shorter number of hops (i.e., shorter path) when a particular threshold is reached or exceeded. Conversely, when the signal falls below the threshold determined at least in part based on the ionosonde readings, the system in one variation switches back to to receive the signal having more hops. The system in one form uses shorter packet lengths for signals travelling over more hops than those transmitted over fewer hops. In one form, the packet size inversely varies generally depending on the transmission and/or arrival angle. For instance, the packet size for a three-hop path is shorter than the packet size for a two-hop path.

While the system will be described with reference to executing financial trading strategies, this system and technique can be used in other situations or industries where time and bandwidth are of concern. For example, this system can be used to perform remote surgery or medical diagnostics, scientific instruments or studies (e.g., for astronomy or physics), controlling dispersed global computer networks, and/or military applications. This system and technique can for example be adapted for incorporation into earthquake/tsunami early warning systems. Certain remote deep water earthquake sensors may provide a signal to institute a complicated cascade of actions to protect designated population centers and associated infrastructure depending on the severity and type of earthquake. For instance, upon detecting an earthquake (or resulting tsunami), a sensor or monitoring center can transmit a signal that causes nuclear reactors to immediately scram and/or the power grid to reroute power to emergency infrastructure to alleviate the situation. In another example, the technique can be used for underlying maintenance or enhancements to the communication system itself. By way of a non-limiting example, since the files are typically large, code for programming and/or reprogramming the modems, antennas, and/or other equipment at the receiver station (or transmitter station) can be sent along a high bandwidth, high latency link, such as a fiber optic cable. Alternatively or additionally, some or all of the code can be sent via skywave propagation (e.g., radio) and/or via line of site transmission, such as via microwaves. The code can include one or more programs, libraries, data, and/or subroutines for controlling the equipment depending on various circumstances. The transmitter station via skywave propagation can send a triggering signal to the receiver so as to select all or part of the code to

execute so as to modify or reprogram the equipment at the receiver station. For instance, the code can be used to tune the receiver station for particular characteristics, such as for reducing latency, power consumption, and/or error (and/or increasing bandwidth). These tuning characteristics can include tradeoffs that do not work well under certain operational conditions, times, and/or environmental characteristics. One subroutine in the code for example can be optimized for latency reduction, another for error reduction, and still yet another for conserving power. The triggering signal in this example can be used to select one of these subroutines so as to reprogram the receiver depending on the needs at that particular time. The resulting changes can be software changes that change the function of the equipment and/or physical changes to the equipment, such as to the height and/or angle of the antenna system. Later on, depending on the needs at that time, different subroutines, programs, data, and/or areas of the code can be selected via the triggering signal. Updates or changes to the code can be sent periodically, continuously, or on an as-needed basis.

Further forms, objects, features, aspects, benefits, advantages, and embodiments of the present invention will become apparent from a detailed description and drawings provided herewith.

BRIEF DESCRIPTION OF THE DRAWINGS

FIG. 1 is a schematic diagram of a system for transmitting data over separate communication links, one of which uses skywave propagation.

FIG. 2 is a schematic diagram further illustrating the skywave propagation of FIG. 1

5 FIG. 3 is a schematic diagram illustrating the use of ground-based repeaters in the skywave propagation of FIG. 1.

FIG. 4 is a schematic diagram illustrating the use of airborne repeaters in the skywave propagation of FIG. 1.

10 FIG. 5 is a schematic diagram illustrating additional layers of the atmosphere including the ionized layer shown in FIG. 1.

FIG. 6 is a schematic diagram illustrating various ionized layers of the atmosphere shown in FIG. 5.

FIG. 7 is a schematic diagram illustrating additional details of skywave propagation generally illustrated in FIGS. 1-6.

15 FIG. 8 is a schematic diagram illustrating the use of sensors at reflection points in the skywave propagation of FIG. 1.

FIG. 9 is a schematic diagram illustrating additional detail for the communication nodes of FIG. 1.

20 FIG. 10 is a flowchart illustrating a method of transmitting data using skywave propagation.

DESCRIPTION OF THE SELECTED EMBODIMENTS

For the purpose of promoting an understanding of the principles of the invention, reference will now be made to the embodiments illustrated in the drawings and specific language will be used to describe the same. It will nevertheless be understood that no
5 limitation of the scope of the invention is thereby intended. Any alterations and further modifications in the described embodiments, and any further applications of the principles of the invention as described herein are contemplated as would normally occur to one skilled in the art to which the invention relates. One embodiment of the invention is shown in great detail, although it will be apparent to those skilled in the relevant art that some features that
10 are not relevant to the present invention may not be shown for the sake of clarity.

FIG. 1 illustrates at 100 one example of a system configured to transfer data via a low latency, low bandwidth communication link 104, and separate data via a high latency, high bandwidth communication link 108. The communication links 104 and 108 provide separate connections between a first communication node 112 and a second communication node 116.
15 The low latency connection 104 may be configured to transmit data using electromagnetic waves 124 passing through free space via skywave propagation. The electromagnetic waves 124 may be generated by a transmitter in the first communication node 112, passed along a transmission line 136 to an antenna 128. The electromagnetic waves 124 may be radiated by the antenna 128 encountering an ionized portion of the atmosphere 120. This radiated
20 electromagnetic energy may then be refracted by the ionized portion of the atmosphere 120 causing the waves 124 to redirect toward earth. The waves 124 may be received by a receiving antenna 132 coupled to the second communications node 116 by the transmission line 140. As illustrated in FIG. 1, a transmitting communication node may use skywave propagation to transmit electromagnetic energy long distances across the earth surface without the need of
25 one or more transmission lines to carry the electromagnetic energy.

Data may also be transmitted between the communications nodes 112 and 116 using a high latency communication link 108. As illustrated in FIG. 1, the high latency communication link 108 may be implemented using a transmission line 144 passing through the earth, which may include passing under or through an ocean or other body of water. As
30 shown in FIG. 1, the high latency communication link 108 may include repeaters 152. FIG. 1 illustrates four repeaters 152 along the transmission line 144 although any suitable number of repeaters 152 may be used. The transmission line 144 may also have no repeaters at all. Although FIG. 1 illustrates the communication link 104 transmitting information from the first

communication node 112 to the second communication node 116, the data transmitted may pass along the communication links 104, 108 in both directions.

A client 160 may have a connection 164 to the first communication node 112. The client 160 may send instructions over the connection 164 to the first communication node 112.
5 At the first communication node 112, the instructions are prepared to be sent to the second communication node 116, either by the low latency link 104 or the high latency link 108, or both. The second communication node 116 may be connected to an instruction processor 168 by a connection 172. The client 160 may be any business, group, individual, or entity that desires to send directions over a distance. The instruction processor 168 may be any business,
10 group, individual, or entity that is meant to receive or act upon those instructions. In some embodiments, the connections 164 and 172 may be unnecessary as the client may send the data to be transmitted directly from the communication node 112 or the communication node 116 may be connected directly to the instruction processor 168. The system 100 may be used for any kind of low-latency data transmission that is desired. As one example, the client 160
15 may be a doctor or surgeon working remotely while the instruction processor 168 may be a robotic instrument for working on a patient.

In some embodiments, the client 160 may be a financial instrument trader and the instruction processor 168 may be a stock exchange. The trader may wish to provide instructions to the stock exchange to buy or sell certain securities or bonds at specific times.
20 Alternatively or additionally, the instructions are in the form of news and/or other information supplied by the trader and/or a third party organization, such as a news organization or a government. The trader may transmit the instructions to the first communication node 112 which sends the instructions and/or news to second communication node using the antennae 128, 132 or by the transmission line 144. The stock exchange can then process the actions
25 desired by the trader upon receipt of the instructions and/or news.

The system 100 may be useful for high-frequency trading, where trading strategies are carried out on computers to execute trades in fractions of a second. In high-frequency trading, a delay of mere milliseconds may cost a trader millions of dollars; therefore, the speed of transmission of trading instructions is as important as the accuracy of the data transmitted. In
30 some embodiments, the trader may transmit preset trading instructions or conditions for executing a trade to the communication node 116, which is located within close proximity to a stock exchange, using the high latency, high bandwidth communication link 108 at a time before the trader wishes to execute a trade. These instructions or conditions may require the

transmission of a large amount of data, and may be delivered more accurately using the higher bandwidth communication link 108. Also, if the instructions or conditions are sent at a time prior to when a trade is wished to be executed, the higher latency of the communication link 108 can be tolerated.

5 The eventual execution of the instructions may be accomplished by the trader transmitting triggering data to the system on which the instructions are stored. Alternatively or additionally, the triggering data can include news and/or other information supplied by the trader and/or a separate, third party organization. Upon receipt of the triggering data, the trading instructions are sent to the stock exchange and a trade is executed. The triggering data
10 that is transmitted is generally a much smaller amount of data than the instructions; therefore, the triggering data may be sent over the low latency, low bandwidth communication link 104. When the triggering data is received at communication node 116, the instructions for a specific trade are sent to the stock exchange. Sending the triggering data over the low latency
15 communication link 104 rather than the high latency communication link 108 allows the desired trade to be executed as quickly as possible, giving the trader a time advantage over other parties trading the same financial instruments.

 The configuration shown in FIG. 1 is further illustrated in FIG. 2 where the first communication node 112 and the second communication node 116 are geographically remote from one another separated by a substantial portion of the surface of the earth (156). This
20 portion of the earth's surface may include one or more continents, oceans, mountain ranges, or other geographic areas. For example, the distance spanned in FIGS. 1-7 may cover a single continent, multiple continents, an ocean, and the like. In one example, the first communication node 112 is in Chicago, Ill. in the United States of America, and the second communication node 116 is in London, England, in the United Kingdom. In another example, the first
25 communication node 112 is in New York City, N.Y., and second communication node 116 is in Los Angeles, Calif., both cities being in North America. Any suitable combination of distance, communication nodes, and communications links is envisioned that can provide satisfactory latency and bandwidth.

 FIG. 2 illustrates that skywave propagation allows electromagnetic energy to traverse
30 long distances. Using skywave propagation, the low latency communication link 104 transmits the electromagnetic waves 124 into a portion of the atmosphere 120 that is sufficiently ionized to refract the electromagnetic waves 124 toward the earth. The waves may then be reflected by the surface of the earth and returned to the ionized portion of the upper atmosphere 120 where

they may be refracted toward earth again. Thus electromagnetic energy may “skip” repeatedly allowing the low latency, low bandwidth signals 124 to cover distances substantially greater than those which may be covered by non-skywave propagation.

Another example of the system illustrated in FIG. 1 appears in FIG. 3 where the skywave propagation discussed with respect to FIGS. 1 and 2 may be enhanced using repeaters 302 and 306. In this example, the first repeater 302 may receive the low latency communication signals emanating from the antenna 128. The signals may be refracted by the ionized region 120 and returned to earth where they may be received by the repeater 302 and retransmitted via skywave propagation. The refracted signal may be received by the repeater 306 and retransmitted using skywave propagation to the second communications node 116 via the antenna 132. Although two repeating stations are illustrated in FIG. 3, any suitable number, configuration, or positioning of the ground repeating stations 302 is considered. Increasing the number of repeaters 302, 306 may provide for the opportunity to transmit low latency signals over greater distances in a wider array of atmospheric missions, however, the physical limitations of the repeater circuitry that receives and retransmits the signal may add additional latency to low latency communication link 104.

FIG. 4 illustrates another example of the system illustrated in FIG. 1 where one or more repeaters along the first communications link are airborne, such as in an aircraft, dirigible, balloon, or other device 410 configured to maintain the repeater aloft in the atmosphere. In this example, signals transmitted from the first communications node 112 via the antenna 128 may be received by an airborne repeater 414 either as line of sight communication 402, or by skywave propagation as described herein elsewhere. The signals may be received by the airborne repeater 414 and retransmitted as line of sight communication 406, or by skywave propagation to the second communications node 116 along the low latency link 104.

Additional details regarding skywave propagation are illustrated in FIGS. 5-7. The relation to the system disclosed and various layers of the upper atmosphere is illustrated in FIG. 5. For purposes of radio transmission, the layers of the upper atmosphere may be divided as shown into successively higher layers such as the troposphere 504, the stratosphere 508, and the ionosphere 512.

The ionosphere is named as such because it includes a high concentration of ionized particles. The density of these particles in the ionosphere furthest from earth is very low and becomes progressively higher in the areas of the ionosphere closer to earth. The upper region

of the ionosphere is energized by powerful electromagnetic radiation from the sun which includes high-energy ultraviolet radiation. This solar radiation causes ionization of the air into free electrons, positive ions, and negative ions. Even though the density of the air molecules in the upper ionosphere is low, the radiation particles from space are of such high energy that they cause extensive ionization of the relatively few air molecules that are present. The ionization extends down through the ionosphere with diminishing intensity as air becomes denser with the highest degree of ionization thus occurring at the upper extremities of the ionosphere, while the lowest degree occurs in the lower portion of the ionosphere.

These differences in ionization between the upper and lower extremities of the ionosphere 512 are further illustrated in FIG. 6. The ionosphere is illustrated in FIG. 6 with three layers designated, respectively, from lowest level to highest level as D layer 608, E layer 612, and F layer 604. The F layer 604 may be further divided into two layers designated F1 (the higher layer) at 616 and F2 (the lower layer) at 620. The presence or absence of layers 616 and 620 in the ionosphere and their height above the earth vary with the position of the sun. At high noon, radiation from the sun 624 passing into the ionosphere is greatest, tapering off at sunset and at a minimum at night. When the radiation is removed, many of the ions recombine causing the D layer 608 and the E layer 612 to disappear, and further causing the F1 and F2 layers 616, 620 to recombine into a single F layer 604 during the night. Since the position of the sun varies with respect to a given point on earth, the exact characteristics of the layers 608, 612, 616, and 620 of the ionosphere 512 can be extremely difficult to predict but may be determined by experimentation.

The ability for a radio wave to reach a remote location using skywave propagation depends on various factors such as ion density in the layers 608-620 (when they are present), the frequency of the transmitted electromagnetic energy, and the angle of transmission. For example, if the frequency of a radio wave is gradually increased, a point will be reached where the wave cannot be refracted by the D layer 608 which is the least ionized layer of the ionosphere 512. The wave may continue through the D layer 608 and into the E layer 612 where its frequency may still be too great to refract the singles passing through this layer as well. The waves 124 may continue to the F2 layer 620 and possibly into the F1 layer 616 as well before they are bent toward earth. In some cases, the frequency may be above a critical frequency making it impossible for any refraction to occur causing the electromagnetic energy to be radiated out of the earth's atmosphere (708).

Thus, above a certain frequency, electromagnetic energy transmitted vertically continues into space and is not refracted by the ionosphere 512. However, some waves below the critical frequency may be refracted if the angle of propagation 704 is lowered from the vertical. Lowering the angle of propagation 704 also allows the electromagnetic waves 124 transmitted by the antenna 128 to be refracted toward Earth's surface within a skip zone 720 making it possible to traverse a skip distance 724 and reach a remote antenna 132. Thus the opportunity for successful skywave propagation over a certain skip distance 724 is further dependent on the angle of transmission as well as the frequency, and therefore the maximum usable frequency varies with the condition of the ionosphere, desired skip distance 724, and the propagation angle 704. FIG. 7 also illustrates that non-skywave propagation such as groundwave signals and/or line of sight signals 716 are unlikely to traverse the skip distance 724.

Because the properties of transmission of an electromagnetic wave can vary depending on changes in the ionosphere due to environmental conditions such as thunderstorms, solar storms, or even time of day or season, it may be desired to directly measure ionospheric conditions at points in the atmosphere where the electromagnetic waves refract. As shown in FIG. 8, sensors 804 may be positioned to collect data at each of these reflection points 808. Each sensor 804 is positioned so that a reflection point 808 is directly above the sensor 804. However, in other embodiments, a sensor 804 may be positioned so that a direct path between the sensor 804 and the reflection point 808 does not form a vertical line.

The sensors 804 may be ionospheric sensors for determining ionospheric conditions, such as ionospheric height, at a certain atmospheric location, such as a reflection point 808. One type of ionospheric sensor that may be used is an ionosonde. An ionosonde includes a high frequency transmitter and a receiver that may track the frequency of the transmitter. The ionosonde transmits short pulses of electromagnetic waves into the atmosphere, generally vertically upward from its location, sweeping through frequencies located in the high frequency range. These pulses refract off of the ionosphere at varying heights and return to the receiver. The refracted electromagnetic waves may be analyzed by a control system that reviews time between transmission and receipt to calculate reflection height of the electromagnetic waves at different frequencies.

In some embodiments, the sensors 804 may also include weather sensors that can monitor weather conditions such as cloud cover, lightning, or other weather conditions that may affect electromagnetic wave transmission. Some sensors 804 may have the capability to

monitor both ionospheric conditions and weather conditions at a desired location in the atmosphere. For example, a sensor 804 may include an ionosonde and a lightning detector.

As one example, as illustrated in FIG. 8, data may be desired to be transmitted over a long distance, such as from Chicago, Illinois to London, United Kingdom. The transmission may include several hops so that there are multiple reflection points 808 where the data is refracted from the ionosphere. To ensure accurate transmission of the data, it may be desired to monitor ionospheric conditions and weather conditions at each of the reflection points 808. Some ionospheric data is publicly available, for example from the National Oceanic and Atmospheric Administration (NOAA) or other governmental agencies. However, this data may not necessarily be collected from the reflection points 808 of the desired data transmission path. The ionospheric data from locations other than the reflection points 808 may not be accurate enough to ensure successful transmission of data. Therefore, the transmitting party may predetermine the reflection points 808 of the radio transmission path and locate the sensors 804 at the reflection points 808 to monitor ionospheric conditions and other conditions that impact transmission quality.

As shown in FIG. 8, some of the reflection points 808 may be located over a landmass. At these locations, a sensor 804 may be positioned on the ground or on a building or other structure that is located below the reflection point 808, allowing the sensor 804 to measure the conditions at the reflection point 808. Other reflection points 808 of the radio transmission path may be positioned over water, such as a large lake or an ocean. In this situation, a sensor 804 may be fixed in the water on a boat, a platform, an oil rig, a balloon, or some other structure located below the reflection point 808, allowing the sensor 804 to measure the conditions at the reflection point 808.

Data collected from the sensors 804 may be used to improve transmission quality and accuracy of data transmitted by system 100. FIG. 9 illustrates one example of additional aspects of a communication node 900 which is like the communication nodes 112 and 116 from system 100. The communication node 900 can include a processor 904 for controlling various aspects of the communication node 900. The processor may be coupled to a memory 916 useful for storing rules, command data 920, or historical transmission data 922. Devices for accepting user input and providing output (I/O) to a user 924 may also be included. These devices may include a keyboard or keypad, a mouse, a display such as a flat panel monitor and the like, a printer, plotter, or 3D printer, a camera, or a microphone. Any suitable devices for user I/O may be included. The node 900 may also include a network interface 932 responsive

to the processor 904 and coupled to a communication network 936. A security module 928 may be included as well and may be used to reduce or eliminate the opportunity for third-parties to intercept, jam, or change data as it passes between communication nodes 900. In one example, the communication node 900 is implemented as a computer executing software to
5 control the interaction of the various aspects of the node 900.

The network interface 936 may be configured to send and receive data such as command data 920, or triggering data which may be passed from a triggering system 940. The communication network 936 may be coupled to a network such as the internet and configured to send and receive data without the use of skywave propagation. For example, the
10 communication network 936 may transmit and receive data over optical fibers or other transmission lines running along the earth similar to the transmission lines 144 illustrated in previous figures.

The node 900 may include a second network interface 908 responsive to the processor 904 and coupled to a radio-frequency communication interface 912. This second network
15 interface 908 may be used to transfer data such as command data 920 or triggering data passed from the triggering system 940. The network interface 908 may be coupled to an antenna like antenna 128 which may include multiple antennas or antenna elements. The radio-frequency communication interface 908 may be configured to send and receive data such as triggering data using electromagnetic waves transmitted and/or received via antenna 128. As discussed
20 above, antenna 128 may be configured to send and receive the electromagnetic waves via skywave propagation.

The node 900 may receive data streams that are monitored to develop a transmission frequency model 960 that may be stored in memory 920. As shown, multiple data streams may be received by the node 900. The processor 904 may combine the data streams to create
25 a fused data stream that serves as the input for the transmission frequency model 960. In the embodiment shown in FIG. 9, one of the fused data streams may be transmission data 944 that can include in-band data, out-of-band data, public data, and/or private data. The transmission frequency model 960 may be developed to be able to analyze distortion or other errors in the transmission data to determine an optimum frequency for transmission. Other data sources for
30 the fused data stream may include ionosphere data 948. The ionosphere data 948 may be collected by the sensors 904 positioned at the reflection points 908 of the transmission path. The ionospheric data 948 may also include other publicly available sources of ionosphere data either in real-time or from historical record. Weather data 952 collected by the sensors 904 or

other publicly or privately recorded weather data may also be collected at node 900 and used as an input to the transmission frequency model 960. Although FIG. 9 shows three types of inputs for the transmission frequency model 960, in other embodiments, more inputs may be used or fewer inputs may be used as desired. For example, the transmission frequency model 5 960 may include only transmission data 944 and ionosphere data 948.

The transmission frequency model 960 may use the transmission data 944, ionosphere data 948, weather data 952, and other relevant data streams to determine an optimum working frequency for data transmission based on the current conditions. The transmission frequency model 960 may also be configured to predict future ionospheric and other conditions that may 10 have an effect on the quality of data transmission. These predictions may allow the model 960 to determine that a future switch in frequency may be necessary to maintain optimum data transmission as well as at which time a switch to a different frequency may be necessary. The model 960 may also use the information from the fused data stream created from the data inputs 944, 948, and 952 to encode or decode a transmitted signal based on the properties of 15 the transmitted data.

In some embodiments, when data transmission from a client 160 to an instruction processor 168 is not needed, the antenna 128 may operate in broadcast mode, transmitting publicly available digital content such as music, news, or other forms of information. Sensors 804 may monitor the characteristics of the digital broadcast signal along the transmission path. 20 The data collected by the sensors 804 may be used to model the degradation of the signal and frequency of the digital broadcast. This data may be part of the input to the transmission frequency model 960 for determining future data transmission frequencies as well as timing to switch to different frequencies to achieve optimum data transmission and avoid errors and data distortion.

FIG. 10 is a flowchart 1000 illustrating a method of transmitting data using skywave propagation. The location of a reflection point of the data transmission path of the transmitted data stream is determined 1005. A sensor is then positioned to directly measure 1010 atmospheric condition data at the determined reflection point. In some embodiments, the sensor may be positioned directly below the reflection point. In other embodiments, the 30 sensor may be positioned at a location that is angled with respect to the reflection point. The atmospheric condition data collected by the sensor is used as an input 1015 into a transmission frequency model that may be used to determine an optimum working frequency for transmission of the data stream. The data stream is then transmitted 1020 by skywave

propagation at the optimum working frequency determined by the transmission frequency model.

Glossary of Definitions and Alternatives

5 The language used in the claims and specification is to only have its plain and ordinary meaning, except as explicitly defined below. The words in these definitions are to only have their plain and ordinary meaning. Such plain and ordinary meaning is inclusive of all consistent dictionary definitions from the most recently published Webster's and Random House dictionaries. As used in the specification and claims, the following definitions apply to
10 the following terms or common variations thereof (e.g., singular/plural forms, past/present tenses, etc.):

“Antenna” or “Antenna system” generally refers to an electrical device, or series of devices, in any suitable configuration, that converts electric power into electromagnetic radiation. Such radiation may be either vertically, horizontally, or circularly polarized at any
15 frequency along the electromagnetic spectrum. Antennas transmitting with circular polarity may have either right-handed or left-handed polarization.

 In the case of radio waves, an antenna may transmit at frequencies ranging along electromagnetic spectrum from extremely low frequency (ELF) to extremely high frequency (EHF). An antenna or antenna system designed to transmit radio waves may comprise an
20 arrangement of metallic conductors (elements), electrically connected (often through a transmission line) to a receiver or transmitter. An oscillating current of electrons forced through the antenna by a transmitter can create an oscillating magnetic field around the antenna elements, while the charge of the electrons also creates an oscillating electric field along the elements. These time-varying fields radiate away from the antenna into space as a
25 moving transverse electromagnetic field wave. Conversely, during reception, the oscillating electric and magnetic fields of an incoming electromagnetic wave exert force on the electrons in the antenna elements, causing them to move back and forth, creating oscillating currents in the antenna. These currents can then be detected by receivers and processed to retrieve digital or analog signals or data.

30 Antennas can be designed to transmit and receive radio waves substantially equally in all horizontal directions (omnidirectional antennas), or preferentially in a particular direction (directional or high gain antennas). In the latter case, an antenna may also include additional elements or surfaces which may or may not have any physical electrical connection to the

transmitter or receiver. For example, parasitic elements, parabolic reflectors or horns, and other such non-energized elements serve to direct the radio waves into a beam or other desired radiation pattern. Thus antennas may be configured to exhibit increased or decreased directionality or “gain” by the placement of these various surfaces or elements. High gain
5 antennas can be configured to direct a substantially large portion of the radiated electromagnetic energy in a given direction that may be vertical horizontal or any combination thereof.

Antennas may also be configured to radiate electromagnetic energy within a specific range of vertical angles (i.e. “takeoff angles) relative to the earth in order to focus
10 electromagnetic energy toward an upper layer of the atmosphere such as the ionosphere. By directing electromagnetic energy toward the upper atmosphere at a specific angle, specific skip distances may be achieved at particular times of day by transmitting electromagnetic energy at particular frequencies.

Other examples of antennas include emitters and sensors that convert electrical energy
15 into pulses of electromagnetic energy in the visible or invisible light portion of the electromagnetic spectrum. Examples include light emitting diodes, lasers, and the like that are configured to generate electromagnetic energy at frequencies ranging along the electromagnetic spectrum from far infrared to extreme ultraviolet.

20 **“Command”** or **“Command Data”** generally refers to one or more directives, instructions, algorithms, or rules controlling a machine to take one or more actions, alone or in combination. A command may be stored, transferred, transmitted, or otherwise processed in any suitable manner. For example, a command may be stored in a memory or transmitted over a communication network as electromagnetic radiation at any suitable frequency passing
25 through any suitable medium.

“Computer” generally refers to any computing device configured to compute a result from any number of input values or variables. A computer may include a processor for performing calculations to process input or output. A computer may include a memory for
30 storing values to be processed by the processor, or for storing the results of previous processing.

A computer may also be configured to accept input and output from a wide array of input and output devices for receiving or sending values. Such devices include other

computers, keyboards, mice, visual displays, printers, industrial equipment, and systems or machinery of all types and sizes. For example, a computer can control a network interface to perform various network communications upon request. The network interface may be part of the computer, or characterized as separate and remote from the computer.

5 A computer may be a single, physical, computing device such as a desktop computer, a laptop computer, or may be composed of multiple devices of the same type such as a group of servers operating as one device in a networked cluster, or a heterogeneous combination of different computing devices operating as one computer and linked together by a communication network. The communication network connected to the computer may also be
10 connected to a wider network such as the internet. Thus computer may include one or more physical processors or other computing devices or circuitry, and may also include any suitable type of memory.

 A computer may also be a virtual computing platform having an unknown or fluctuating number of physical processors and memories or memory devices. A computer may
15 thus be physically located in one geographical location or physically spread across several widely scattered locations with multiple processors linked together by a communication network to operate as a single computer.

 The concept of “computer” and “processor” within a computer or computing device also encompasses any such processor or computing device serving to make calculations or
20 comparisons as part of disclosed system. Processing operations related to threshold comparisons, rules comparisons, calculations, and the like occurring in a computer may occur, for example, on separate servers, the same server with separate processors, or on a virtual computing environment having an unknown number of physical processors as described above.

25 A computer may be optionally coupled to one or more visual displays and/or may include an integrated visual display. Likewise, displays may be of the same type, or a heterogeneous combination of different visual devices. A computer may also include one or more operator input devices such as a keyboard, mouse, touch screen, laser or infrared pointing device, or gyroscopic pointing device to name just a few representative examples.
30 Also, besides a display, one or more other output devices may be included such as a printer, plotter, industrial manufacturing machine, 3D printer, and the like. As such, various display, input and output device arrangements are possible.

Multiple computers or computing devices may be configured to communicate with one another or with other devices over wired or wireless communication links to form a communication network. Network communications may pass through various computers operating as network appliances such as switches, routers, firewalls or other network devices or interfaces before passing over other larger computer networks such as the internet. Communications can also be passed over the communication network as wireless data transmissions carried over electromagnetic waves through transmission lines or free space. Such communications include using WiFi or other Wireless Local Area Network (WLAN) or a cellular transmitter/receiver to transfer data. Such signals conform to any of a number of wireless or mobile telecommunications technology standards such as 802.11a/b/g/n, 3G, 4G, and the like.

“Communication Link” generally refers to a connection between two or more communicating entities and may or may not include a communications channel between the communicating entities. The communication between the communicating entities may occur by any suitable means. For example the connection may be implemented as an actual physical link, an electrical link, an electromagnetic link, a logical link, or any other suitable linkage facilitating communication.

In the case of an actual physical link, communication may occur by multiple components in the communication link figured to respond to one another by physical movement of one element in relation to another. In the case of an electrical link, the communication link may be composed of multiple electrical conductors electrically connected to form the communication link.

In the case of an electromagnetic link, elements the connection may be implemented by sending or receiving electromagnetic energy at any suitable frequency, thus allowing communications to pass as electromagnetic waves. These electromagnetic waves may or may not pass through a physical medium such as an optical fiber, or through free space, or any combination thereof. Electromagnetic waves may be passed at any suitable frequency including any frequency in the electromagnetic spectrum.

In the case of a logical link, the communication link may be a conceptual linkage between the sender and recipient such as a transmission station in the receiving station. Logical link may include any combination of physical, electrical, electromagnetic, or other types of communication links.

“**Communication node**” generally refers to a physical or logical connection point, redistribution point or endpoint along a communication link. A physical network node is generally referred to as an active electronic device attached or coupled to a communication link, either physically, logically, or electromagnetically. A physical node is capable of sending, receiving, or forwarding information over a communication link. A communication node may or may not include a computer, processor, transmitter, receiver, repeater, and/or transmission lines, or any combination thereof.

“**Critical angle**” generally refers to the highest angle with respect to a vertical line extending to the center of the Earth at which an electromagnetic wave at a specific frequency can be returned to the Earth using sky-wave propagation.

“**Critical Frequency**” generally refers to the highest frequency that will be returned to the Earth when transmitted vertically under given ionospheric conditions using sky-wave propagation.

“**Data Bandwidth**” generally refers to the maximum throughput of a logical or physical communication path in a communication system. Data bandwidth is a transfer rate that can be expressed in units of data transferred per second. In a digital communications network, the units of data transferred are bits and the maximum throughput of a digital communications network is therefore generally expressed in “bits per second” or “bit/s.” By extension, the terms “kilobit/s” or “Kbit/s”, “Megabit/s” or “Mbit/s”, and “Gigabit/s” or “Gbit/s” can also be used to express the data bandwidth of a given digital communications network. Data networks may be rated according to their data bandwidth performance characteristics according to specific metrics such as “peak bit rate”, “mean bit rate”, “maximum sustained bit rate”, “information rate”, or “physical layer useful bit rate.” For example, bandwidth tests measure the maximum throughput of a computer network. The reason for this usage is that according to Hartley's Law, the maximum data rate of a physical communication link is proportional to its frequency bandwidth in hertz.

Data bandwidth may also be characterized according to the maximum transfer rate for a particular communications network. For example:

“**Low Data Bandwidth**” generally refers to a communications network with a maximum data transfer rate that is less than or about equal to 1,000,000 units of data per second. For example, in a digital communications network, the unit of data is a bit. Therefore low data bandwidth digital communications networks are networks with a maximum transfer rate that is less than or about equal to 1,000,000 bits per second (1 Mbits/s).

“**High Data Bandwidth**” generally refers to a communications network with a maximum data transfer rate that is greater than about 1,000,000 units of data per second. For example, a digital communications network with a high data bandwidth is a digital communications network with a maximum transfer rate that is greater than about 1,000,000 bits per second (1 Mbits/s).

“**Electromagnetic Radiation**” generally refers to energy radiated by electromagnetic waves. Electromagnetic radiation is produced from other types of energy, and is converted to other types when it is destroyed. Electromagnetic radiation carries this energy as it travels moving away from its source at the speed of light (in a vacuum). Electromagnetic radiation also carries both momentum and angular momentum. These properties may all be imparted to matter with which the electromagnetic radiation interacts as it moves outwardly away from its source.

Electromagnetic radiation changes speed as it passes from one medium to another. When transitioning from one media to the next, the physical properties of the new medium can cause some or all of the radiated energy to be reflected while the remaining energy passes into the new medium. This occurs at every junction between media that electromagnetic radiation encounters as it travels.

The photon is the quantum of the electromagnetic interaction, and is the basic constituent of all forms of electromagnetic radiation. The quantum nature of light becomes more apparent at high frequencies as electromagnetic radiation behaves more like particles and less like waves as its frequency increases.

“**Distortion**” generally refers to the alteration of the original shape or other characteristic of something, and more specifically, to the alteration of the waveform of an information-bearing signal. Distortions can include, but are not limited to, amplitude, harmonic, frequency, phase, polarization, and group delay type distortions. Distortions can

include linear, nonlinear, systematic, and/or random changes to the information-bearing signal. Distortions can include changes to analog and/or digital signals.

“**Electromagnetic Spectrum**” generally refers to the range of all possible frequencies of electromagnetic radiation. The electromagnetic spectrum is generally categorized as follows, in order of increasing frequency and energy and decreasing wavelength:

“**Extremely low frequency**” (ELF) generally designates a band of frequencies from about 3 to about 30 Hz with wavelengths from about 100,000 to 10,000 km long.

“**Super low frequency**” (SLF) generally designates a band of frequencies generally ranging between about 30 Hz to about 300 Hz with wavelengths of about 10,000 to about 1000 km long.

“**Voice frequency**” or “**voice band**” generally designates electromagnetic energy that is audible to the human ear. Adult males generally speak in the range between about 85 and about 180 Hz while adult females generally converse in the range from about 165 to about 255 Hz.

“**Very low frequency**” (VLF) generally designates the band of frequencies from about 3 kHz to about 30 kHz with corresponding wavelengths from about 10 to about 100 km long.

“**Low-frequency**” (LF) generally designates the band of frequencies in the range of about 30 kHz to about 300 kHz with wavelengths range from about 1 to about 10 km.

“**Medium frequency**” (MF) generally designates the band of frequencies from about 300 kHz to about 3 MHz with wavelengths from about 1000 to about 100 m long.

“**High frequency**” (HF) generally designates the band of frequencies from about 3 MHz to about 30 MHz having wavelengths from about 100 m to about 10 m long.

“**Very high frequency**” (VHF) generally designates the band of frequencies from about 30 Hz to about 300 MHz with wavelengths from about 10 m to about 1 m long.

“**Ultra high frequency**” (UHF) generally designates the band of frequencies from about 300 MHz to about 3 GHz with weight wavelengths ranging from about 1 m to about 10 cm long.

“**Super high frequency**” (SHF) generally designates the band of frequencies from about 3 GHz to about 30 GHz with wavelengths ranging from about 10 cm to about 1 cm long.

5 “**Extremely high frequency**” (EHF) generally designates the band of frequencies from about 30 GHz to about 300 GHz with wavelengths ranging from about 1 cm to about 1 mm long.

“**Far infrared**” (FIR) generally designates a band of frequencies from about 300 GHz to about 20 THz with wavelengths ranging from about 1 mm to about 15 μm long.

10 “**Long-wavelength infrared**” (LWIR) generally designates a band of frequencies from about 20 THz to about 37 THz with wavelengths ranging from about 15 μm to about 8 μm long.

“**Mid infrared**” (MIR) generally designates a band of frequencies from about 37 THz to about 100 THz with wavelengths from about 8 μm to about 3 μm long.

15 “**Short wavelength infrared**” (SWIR) generally designates a band of frequencies from about 100 THz to about 214 THz with wavelengths from about 3 μm to about 1.4 μm long

“**Near-infrared**” (NIR) generally designates a band of frequencies from about 214 THz to about 400 THz with wavelengths from about 1.4 μm to about 750 nm long.

20 “**Visible light**” generally designates a band of frequencies from about 400 THz to about 750 THz with wavelengths from about 750 nm to about 400 nm long.

“**Near ultraviolet**” (NUV) generally designates a band of frequencies from about 750 THz to about 1 PHz with wavelengths from about 400 nm to about 300 nm long.

25 “**Middle ultraviolet**” (MUV) generally designates a band of frequencies from about 1 PHz to about 1.5 PHz with wavelengths from about 300 nm to about 200 nm long.

30 “**Far ultraviolet**” (FUV) generally designates a band of frequencies from about 1.5 PHz to about 2.48 PHz with wavelengths from about 200 nm to about 122 nm long.

“**Extreme ultraviolet**” (EUV) generally designates a band of frequencies from about 2.48 PHz to about 30 PHz with wavelengths from about 121 nm to about 10 nm long.

“**Soft x-rays**” (SX) generally designates a band of frequencies from about 30 PHz to about 3 EHz with wavelengths from about 10 nm to about 100 pm long.

“**Hard x-rays**” (HX) generally designates a band of frequencies from about 3 EHz to about 30 EHz with wavelengths from about 100 pm to about 10 pm long.

5 “**Gamma rays**” generally designates a band of frequencies above about 30 EHz with wavelengths less than about 10 pm long.

“**Electromagnetic Waves**” generally refers to waves having a separate electrical and a magnetic component. The electrical and magnetic components of an electromagnetic wave oscillate in phase and are always separated by a 90 degree angle. Electromagnetic waves can radiate from a source to create electromagnetic radiation capable of passing through a medium or through a vacuum. Electromagnetic waves include waves oscillating at any frequency in the electromagnetic spectrum including, but not limited to, radio waves, visible and invisible light, X-rays, and gamma-rays.

“**Frequency Bandwidth**” or “**Band**” generally refers to a contiguous range of frequencies defined by an upper and lower frequency. Frequency bandwidth is thus typically expressed as a number of hertz (cycles per second) representing the difference between the upper frequency and the lower frequency of the band and may or may not include the upper and lower frequencies themselves. A “band” can therefore be defined by a given frequency bandwidth for a given region and designated with generally agreed on terms. For example, the “20 meter band” in the United States is assigned the frequency range from 14 MHz to 14.35 MHz thus defining a frequency bandwidth of 0.35 MHz or 350 KHz. In another example, the International Telecommunication Union (ITU) has designated the frequency range from 300 Mhz to 3GHz as the “UHF band”.

“**Fiber-optic communication**” generally refers to a method of transmitting data from one place to another by sending pulses of electromagnetic energy through an optical fiber. The transmitted energy may form an electromagnetic carrier wave that can be modulated to carry data. Fiber-optic communication lines that use optical fiber cables to transmit data can be configured to have a high data bandwidth. For example, fiber-optic communication lines may have a high data bandwidth of up to about 15 Tbit/s, about 25 Tbit/s, about 100 Tbit/s, about 1 Pbit/s or more. Opto-electronic repeaters may be used along a fiber-optic communication line to convert the electromagnetic energy from one segment of fiber-optic cable into an electrical signal. The repeater can retransmit the electrical signal as electromagnetic energy along another segment of fiber-optic cable at a higher signal strength than it was received.

“**Financial instrument**” generally refers to a tradable asset of any kind. General examples include, but are not limited to, cash, evidence of an ownership interest in an entity, or a contractual right to receive or deliver cash or another financial instrument. Specific examples include bonds, bills (e.g. commercial paper and treasury bills), stock, loans, deposits, certificates of deposit, bond futures or options on bond futures, short-term interest rate futures, stock options, equity futures, currency futures, interest rate swaps, interest rate caps and floors, interest rate options, forward rate agreements, stock options, foreign-exchange options, foreign-exchange swaps, currency swaps, or any sort of derivative.

“**Ground**” is used more in an electrical/electromagnetic sense and generally refers to the Earth’s surface including land and bodies of water, such as oceans, lakes, and rivers.

“**Ground-wave propagation**” generally refers to a transmission method in which one or more electromagnetic waves are conducted via the boundary of the ground and atmosphere to travel along ground. The electromagnetic wave propagates by interacting with the semi-conductive surface of the earth. In essence, the wave clings to the surfaces so as to follow the curvature of the earth. Typically, but not always, the electromagnetic wave is in the form of a ground or surface wave formed by low-frequency radio waves.

“**Identifier**” generally refers to a name that identifies (that is, labels the identity of) either a unique thing or a unique class of things, where the "object" or class may be an idea, physical object (or class thereof), or physical substance (or class thereof). The abbreviation “ID” often refers to identity, identification (the process of identifying), or an identifier (that is, an instance of identification). An identifier may or may not include words, numbers, letters, symbols, shapes, colors, sounds, or any combination of those.

The words, numbers, letters, or symbols may follow an encoding system (wherein letters, digits, words, or symbols represent ideas or longer identifiers) or they may simply be arbitrary. When an identifier follows an encoding system, it is often referred to as a code or ID code. Identifiers that do not follow any encoding scheme are often said to be arbitrary IDs because they are arbitrarily assigned without meaning in any other context beyond identifying something.

“**In-band data**” generally refers to data that is collected from the main data transmission stream between two communication nodes. Typically, in-band data is the main data transmission sent by the transmitting party. This data may be collected and analyzed to determine the viability of transmitting data at a certain frequency at the ionospheric conditions during the time of transmission.

“Ionosphere” generally refers to the layer of the Earth's atmosphere that contains a high concentration of ions and free electrons and is able to reflect radio waves. The ionosphere includes the thermosphere as well as parts of the mesosphere and exosphere. The ionosphere extends from about 25 to about 600 miles (about 40 to 1,000 km) above the earth's surface.

5 The ionosphere includes a number of layers that undergo considerable variations in altitude, density, and thickness, depending among a number of factors including solar activity, such as sunspots. The various layers of the ionosphere are identified below.

The **“D layer”** of the ionosphere is the innermost layer that ranges from about 25 miles (40 km) to about 55 miles (90 km) above the Earth's surface. The layer has the ability to refract signals of low frequencies, but it allows high frequency radio signals to pass through with some attenuation. The D layer normally, but not in all instances, disappears rapidly after sunset due to rapid recombination of its ions.

10

The **“E layer”** of the ionosphere is the middle layer that ranges from about 55 miles (90 km) to about 90 miles (145 km) above the Earth's surface. The E layer typically has the ability to refract signals with frequencies higher than the D layer. Depending on the conditions, the E layer can normally refract frequencies up to 20 MHz. The rate of ionic recombination in the E layer is somewhat rapid such that after sunset it almost completely disappears by midnight. The E layer can further include what is termed an "E_s-layer" or “sporadic E layer” that is formed by small, thin clouds of intense ionization. The sporadic E layer can reflect radio waves, even frequencies up to 225 MHz, although rarely. Sporadic E layers most often form during summer months, and it has skip distances of around 1,020 miles (1,640 km). With the sporadic E layer, one hop propagation can be about 560 miles (900 km) to up to 1,600 miles (2,500 km), and double hop propagation can be over 2,200 miles (3,500 km).

15

20

The **“F layer”** of the ionosphere is the top layer that ranges from about 90 (145 km) to 310 miles (500 km) or more above the Earth's surface. The ionization in the F layer is typically quite high and varies widely during the day, with the highest ionization occurring usually around noon. During daylight, the F layer separates into two layers, the F₁ layer and the F₂ layer. The F₂ layer is outermost layer and, as such, is located higher than the F₁ layer. Given the atmosphere is rarified at these altitudes, the recombination of ions occur slowly such that F layer remains constantly ionized, either day or night such that most (but not all) skywave propagation of radio waves occur in the F layer, thereby facilitating high frequency (HF) or short wave communication over

25

30

long distances. For example, the F layers are able to refract high frequency, long distance transmissions for frequencies up to 30 MHz.

“**Latency**” generally refers to the time interval between a cause and an effect in a system. Latency is physically a consequence of the limited velocity with which any physical interaction can propagate throughout a system. Latency is physically a consequence of the limited velocity with which any physical interaction can propagate. The speed at which an effect can propagate through a system is always lower than or equal to the speed of light. Therefore every physical system that includes some distance between the cause and the effect will experience some kind of latency. For example, in a communication link or communications network, latency generally refers to the minimum time it takes for data to pass from one point to another. Latency with respect to communications networks may also be characterized as the time it takes energy to move from one point along the network to another. With respect to delays caused by the propagation of electromagnetic energy following a particular propagation path, latency can be categorized as follows:

“**Low Latency**” generally refers to a period of time that is less than or about equal to a propagation time that is 10% greater than the time required for light to travel a given propagation path in a vacuum. Expressed as a formula, low latency is defined as follows:

$$latency_{low} \leq \frac{d}{c} \cdot k \text{ (Equation 1)}$$

where:

d = distance (miles)

c = the speed of light in a vacuum (186,000 miles/sec)

k = a scalar constant of 1.1

For example, light can travel 25,000 miles through a vacuum in about 0.1344 seconds. A “low latency” communication link carrying data over this 25,000 mile propagation path would therefore be capable of passing at least some portion of the data over the link in about 0.14784 seconds or less.

“**High Latency**” generally refers to a period of time that is over 10% greater than the time required for light to travel a given propagation path in a vacuum. Expressed as a formula, high latency is defined as follows:

$$latency_{high} > \frac{d}{c} \cdot k \text{ (Equation 2)}$$

where:

d = distance (miles)

c = the speed of light in a vacuum (186,000 miles/sec)

k = a scalar constant of 1.1

For example, light can travel 8,000 miles through a vacuum in about 0.04301 seconds.

5 A “high latency” communication link carrying data over this transmission path would therefore be capable of passing at least some portion of the data over the link in about 0.04731 seconds or more.

The “high” and “low” latency of a network may be independent of the data bandwidth. Some “high” latency networks may have a high transfer rate that is higher than a “low”
10 latency network, but this may not always be the case. Some “low” latency networks may have a data bandwidth that exceeds the bandwidth of a “high” latency network.

“**Maximum Usable Frequency (MUF)**” generally refers to the highest frequency that is returned to the Earth using sky-wave propagation.

“**Memory**” generally refers to any storage system or device configured to retain data
15 or information. Each memory may include one or more types of solid-state electronic memory, magnetic memory, or optical memory, just to name a few. By way of non-limiting example, each memory may include solid-state electronic Random Access Memory (RAM), Sequentially Accessible Memory (SAM) (such as the First-In, First-Out (FIFO) variety or the Last-In-First-Out (LIFO) variety), Programmable Read Only Memory (PROM), Electronically
20 Programmable Read Only Memory (EPROM), or Electrically Erasable Programmable Read Only Memory (EEPROM); an optical disc memory (such as a DVD or CD ROM); a magnetically encoded hard disc, floppy disc, tape, or cartridge media; or a combination of any of these memory types. Also, each memory may be volatile, nonvolatile, or a hybrid combination of volatile and nonvolatile varieties.

25 “**Noise**” generally refers to one or more disturbances that interfere with and/or prevent reception of a signal and/or information.

“**Non-sky-wave propagation**” generally refers to all forms of transmission, wired and/or wireless, in which the information is not transmitted by reflecting an electromagnetic wave from the ionosphere.

30 “**Optimum Working Frequency**” generally refers to the frequency that provides the most consistent communication path via sky-wave propagation. It can vary over time depending on number of factors, such as ionospheric conditions and time of day. For transmissions using the F₂ layer of the ionosphere the working frequency is generally around

85% of the MUF, and for the E layer, the optimum working frequency will generally be near the MUF.

“**Optical Fiber**” generally refers to an electromagnetic waveguide having an elongate conduit that includes a substantially transparent medium through which electromagnetic energy travels as it traverses the long axis of the conduit. Electromagnetic radiation may be maintained within the conduit by total internal reflection of the electromagnetic radiation as it traverses the conduit. Total internal reflection is generally achieved using optical fibers that include a substantially transparent core surrounded by a second substantially transparent cladding material with a lower index of refraction than the core.

Optical fibers are generally constructed of dielectric material that is not electrically conductive but is substantially transparent. Such materials may or may not include any combination of extruded glass such as silica, fluoride glass, phosphate glass, Chalcogenide glass, or polymeric material such as various types of plastic, or other suitable material and may be configured with any suitable cross-sectional shape, length, or dimension. Examples of electromagnetic energy that may be successfully passed through optical fibers include electromagnetic waves in the near-infrared, mid-infrared, and visible light portion of the electromagnetic spectrum, although electromagnetic energy of any suitable frequency may be used.

“**Out-of-band data**” generally refers to data that is collected from a channel that is independent of the channel through which the main data stream is transmitted. The out-of-band data may be data streams sent by skywave propagation by third parties or may be data streams sent by the transmitting party along a different channel than the main data transmission stream. The data collected may include ionospheric data, for example from an ionosonde, or may be general data that is collected and analyzed to determine the viability of transmitting data at a certain frequency at the current ionospheric conditions.

“**Polarization**” generally refers to the orientation of the electric field (“E-plane”) of a radiated electromagnetic energy wave with respect to the Earth's surface and is determined by the physical structure and orientation of the radiating antenna. Polarization can be considered separately from an antenna's directionality. Thus, a simple straight wire antenna may have one polarization when mounted vertically, and a different polarization when mounted substantially horizontally. As a transverse wave, the magnetic field of a radio wave is at right angles to that of the electric field, but by convention, talk of an antenna's “polarization” is understood to refer to the direction of the electric field.

Reflections generally affect polarization. For radio waves, one important reflector is the ionosphere which can change the wave's polarization. Thus for signals received via reflection by the ionosphere (a skywave), a consistent polarization cannot be expected. For line-of-sight communications or ground wave propagation, horizontally or vertically polarized transmissions generally remain in about the same polarization state at the receiving location. Matching the receiving antenna's polarization to that of the transmitter may be especially important in ground wave or line of sight propagation but may be less important in skywave propagation.

An antenna's linear polarization is generally along the direction (as viewed from the receiving location) of the antenna's currents when such a direction can be defined. For instance, a vertical whip antenna or Wi-Fi antenna vertically oriented will transmit and receive in the vertical polarization. Antennas with horizontal elements, such as most rooftop TV antennas, are generally horizontally polarized (because broadcast TV usually uses horizontal polarization). Even when the antenna system has a vertical orientation, such as an array of horizontal dipole antennas, the polarization is in the horizontal direction corresponding to the current flow.

Polarization is the sum of the E-plane orientations over time projected onto an imaginary plane perpendicular to the direction of motion of the radio wave. In the most general case, polarization is elliptical, meaning that the polarization of the radio waves varies over time. Two special cases are linear polarization (the ellipse collapses into a line) as we have discussed above, and circular polarization (in which the two axes of the ellipse are equal). In linear polarization the electric field of the radio wave oscillates back and forth along one direction; this can be affected by the mounting of the antenna but usually the desired direction is either horizontal or vertical polarization. In circular polarization, the electric field (and magnetic field) of the radio wave rotates At the radio frequency circularly around the axis of propagation.

“Private data” generally refers to ionospheric data that is collected from sources that are not available to the general public. Private data may be historical or current ionospheric data collected by the party that is performing data transmission, or may be ionospheric data that is purchased from a third party by the party that is performing data transmission. Private data may also be high frequency data transmissions sent by skywave propagation that may be collected and analyzed for transmission properties, such as distortion, that may indicate the viability of a certain transmission frequency.

“**Processor**” generally refers to one or more electronic components configured to operate as a single unit configured or programmed to process input to generate an output. Alternatively, when of a multi-component form, a processor may have one or more components located remotely relative to the others. One or more components of each processor may be of the electronic variety defining digital circuitry, analog circuitry, or both. In one example, each processor is of a conventional, integrated circuit microprocessor arrangement, such as one or more PENTIUM, i3, i5 or i7 processors supplied by INTEL Corporation of 2200 Mission College Boulevard, Santa Clara, Calif. 95052, USA.

Another example of a processor is an Application-Specific Integrated Circuit (ASIC). An ASIC is an Integrated Circuit (IC) customized to perform a specific series of logical operations is controlling the computer to perform specific tasks or functions. An ASIC is an example of a processor for a special purpose computer, rather than a processor configured for general-purpose use. An application-specific integrated circuit generally is not reprogrammable to perform other functions and may be programmed once when it is manufactured.

In another example, a processor may be of the “field programmable” type. Such processors may be programmed multiple times “in the field” to perform various specialized or general functions after they are manufactured. A field-programmable processor may include a Field-Programmable Gate Array (FPGA) in an integrated circuit in the processor. FPGA may be programmed to perform a specific series of instructions which may be retained in nonvolatile memory cells in the FPGA. The FPGA may be configured by a customer or a designer using a hardware description language (HDL). In FPGA may be reprogrammed using another computer to reconfigure the FPGA to implement a new set of commands or operating instructions. Such an operation may be executed in any suitable means such as by a firmware upgrade to the processor circuitry.

Just as the concept of a computer is not limited to a single physical device in a single location, so also the concept of a “processor” is not limited to a single physical logic circuit or package of circuits but includes one or more such circuits or circuit packages possibly contained within or across multiple computers in numerous physical locations. In a virtual computing environment, an unknown number of physical processors may be actively processing data, the unknown number may automatically change over time as well.

The concept of a “processor” includes a device configured or programmed to make threshold comparisons, rules comparisons, calculations, or perform logical operations applying a rule to data yielding a logical result (e.g. “true” or “false”). Processing activities may occur in multiple single processors on separate servers, on multiple processors in a single server with separate processors, or on multiple processors physically remote from one another in separate computing devices.

“**Public data**” generally refers to ionospheric data that is freely available to the public or any interested party. Public data may be ionosonde data collected and made available by governmental agencies such as NASA, the National Oceanic and Atmospheric Administration (NOAA), or any other public entity that collects and distributes ionospheric data. Public data may be historic data or real-time data. Public data may also be high frequency data transmissions sent by skywave propagation that may be collected and analyzed for transmission properties, such as distortion, that may indicate the viability of a certain transmission frequency.

“**Radio**” generally refers to electromagnetic radiation in the frequencies that occupy the range from 3 kHz to 300 GHz.

“**Radio horizon**” generally refers the locus of points at which direct rays from an antenna are tangential to the ground. The radio horizon can be approximated by the following equation:

$$d \cong \sqrt{2h_t} + \sqrt{2h_r} \text{ (Equation 3)}$$

where:

d = radio horizon (miles)

h_t = transmitting antenna height (feet)

h_r = receiving antenna height (feet).

“**Remote**” generally refers to any physical, logical, or other separation between two things. The separation may be relatively large, such as thousands or millions of miles or kilometers, or small such as nanometers or millionths of an inch. Two things “remote” from one another may also be logically or physically coupled or connected together.

“**Receive**” generally refers to accepting something transferred, communicated, conveyed, relayed, dispatched, or forwarded. The concept may or may not include the act of listening or waiting for something to arrive from a transmitting entity. For example, a transmission may be received without knowledge as to who or what transmitted it. Likewise

the transmission may be sent with or without knowledge of who or what is receiving it. To “receive” may include, but is not limited to, the act of capturing or obtaining electromagnetic energy at any suitable frequency in the electromagnetic spectrum. Receiving may occur by sensing electromagnetic radiation. Sensing electromagnetic radiation may involve detecting energy waves moving through or from a medium such as a wire or optical fiber. Receiving includes receiving digital signals which may define various types of analog or binary data such as signals, datagrams, packets and the like.

“**Receiving Station**” generally refers to a receiving device, or to a location facility having multiple devices configured to receive electromagnetic energy. A receiving station may be configured to receive from a particular transmitting entity, or from any transmitting entity regardless of whether the transmitting entity is identifiable in advance of receiving the transmission.

“**Reflection point**” generally refers to the location in the ionosphere at which a radio wave is refracted by the ionosphere so that it begins to travel back to the surface of the earth rather than further into the atmosphere.

“**Sensor**” generally refers to any device that detects or measures a physical property. The physical property that is measured may be an atmospheric condition, but this is not required. For example, a sensor may measure atmospheric conditions, such as ionospheric height. A sensor may also collect data related to temperature, wind speed, lightning, or any of a number of other weather related parameters. A sensor may be limited to the measurement of a single physical property or may be capable of measuring several different physical properties.

“**Skip distance**” generally refers to the minimum distance from a transmitter to where a wave from sky-wave propagation can be returned to the Earth. To put it another way, the skip distance is the minimum distance that occurs at the critical angle for sky-wave propagation.

“**Skip zone**” or “**quiet zone**” generally refers to is an area between the location where a ground wave from ground wave propagation is completely dissipated and the location where the first sky wave returns using sky wave propagation. In the skip zone, no signal for a given transmission can be received.

“**Satellite communication**” or “**satellite propagation**” generally refers to transmitting one or more electromagnetic signals to a satellite which in turn reflects and/or retransmits the signal to another satellite or station.

5 “**Size**” generally refers to the extent of something; a thing's overall dimensions or magnitude; how big something is. For physical objects, size may be used to describe relative terms such as large or larger, high or higher, low or lower, small or smaller, and the like. Size of physical objects may also be given in fixed units such as a specific width, length, height, distance, volume, and the like expressed in any suitable units.

10 For data transfer, size may be used to indicate a relative or fixed quantity of data being manipulated, addressed, transmitted, received, or processed as a logical or physical unit. Size may be used in conjunction with the amount of data in a data collection, data set, data file, or other such logical unit. For example, a data collection or data file may be characterized as having a “size” of 35 Mbytes, or a communication link may be characterized as having a data bandwidth with a “size” of 1000 bits per second.

15 “**Sky-wave propagation**” refers generally to a transmission method in which one or more electromagnetic-waves radiated from an antenna are refracted from the ionosphere back to the ground. Sky-wave propagation further includes tropospheric scatter transmissions. In one form, a skipping method can be used in which the waves refracted from the ionosphere are reflected by the ground back up to the ionosphere. This skipping can occur more than once.

20 “**Space-wave propagation**” or sometimes referred to as “**direct wave propagation**” or “**line-of-sight propagation**” generally refers to a transmission method in which one or more electromagnetic waves are transmitted between antennas that are generally visible to one another. The transmission can occur via direct and/or ground reflected space waves. Generally speaking, the antenna height and curvature of the earth are limiting factors for the transmission distances for space-wave propagation. The actual radio horizon for a direct line of sight is larger than the visible or geometric line of sight due to diffraction effects; that is, the radio horizon is about 4/5 greater than the geometric line of sight.

30 “**Spread spectrum**” generally refers to a transmission method that includes sending a portion of a transmitted signal over multiple frequencies. The transmission over multiple frequencies may occur simultaneously by sending a portion of the signal on various frequencies. In this example, a receiver must listen to all frequencies simultaneously in order to reassemble the transmitted signal. The transmission may also be spread over multiple frequencies by “hopping” signals. A signal hopping scenario includes transmitting the signal

for some period of time over a first frequency, switching to transmit the signal over a second frequency for a second period of time, before switching to a third frequency for a third period of time, and so forth. The receiver and transmitter must be synchronized in order to switch frequencies together. This process of “hopping” frequencies may be implemented in a
5 frequency-hopping pattern that may change over time (e.g. every hour, every 24 hours, and the like).

“**Stratosphere**” generally refers to a layer of the Earth’s atmosphere extending from the troposphere to about 25 to 35 miles above the earth surface.

“**Transfer Rate**” generally refers to the rate at which a something is moved from one
10 physical or logical location to another. In the case of a communication link or communication network, a transfer rate may be characterized as the rate of data transfer over the link or network. Such a transfer rate may be expressed in “bits per second” and may be limited by the maximum data bandwidth for a given network or communication link used to carry out a transfer of data.

“**Transmission frequency model**” generally refers to a method of determining a
15 suitable frequency for data transmission along a consistent communication path via skywave propagation. The transmission frequency model may be used to determine a suitable frequency for transmission in real time and/or may be used to predict future suitable frequencies as well as when to switch frequency of data transmission. A transmission
20 frequency model may accept various types of data as an input, for example transmitted data streams, environmental data, historical data, and any other desired types of data for determining a transmission frequency. In some instances, a transmission frequency model may be a computer program and stored in computer memory and operable using a computer processor.

“**Transmission line**” generally refers to a specialized physical structure or series of
25 structures designed to carry electromagnetic energy from one location to another, usually without radiating the electromagnetic energy through free space. A transmission line operates to retain and transfer electromagnetic energy from one location to another while minimizing latency and power losses incurred as the electromagnetic energy passes through the structures
30 in the transmission line.

Examples of transmission lines that may be used in communicating radio waves include twin lead, coaxial cable, microstrip, strip line, twisted-pair, star quad, lecher lines, various types of waveguide, or a simple single wire line. Other types of transmission lines

such as optical fibers may be used for carrying higher frequency electromagnetic radiation such as visible or invisible light.

“**Transmission Path**” or “**Propagation Path**” generally refers to path taken by electromagnetic energy passing through space or through a medium. This can include transmissions through a transmission line. In this case, the transmission path is defined by, follows, is contained within, passes through, or generally includes the transmission line. A transmission or propagation path need not be defined by a transmission line. A propagation or transmission path can be defined by electromagnetic energy moving through free space or through the atmosphere such as in skywave, ground wave, line-of-site, or other forms of propagation. In that case, the transmission path can be characterized as any path along which the electromagnetic energy passes as it moves from the transmitter to the receiver, including any skip, bounce, scatter, or other variations in the direction of the transmitted energy.

“**Transmission Station**” generally refers to a transmitting device, or to a location or facility having multiple devices configured to transmit electromagnetic energy. A transmission station may be configured to transmit to a particular receiving entity, to any entity configured to receive transmission, or any combination thereof.

“**Transmit**” generally refers to causing something to be transferred, communicated, conveyed, relayed, dispatched, or forwarded. The concept may or may not include the act of conveying something from a transmitting entity to a receiving entity. For example, a transmission may be received without knowledge as to who or what transmitted it. Likewise the transmission may be sent with or without knowledge of who or what is receiving it. To “transmit” may include, but is not limited to, the act of sending or broadcasting electromagnetic energy at any suitable frequency in the electromagnetic spectrum. Transmissions may include digital signals which may define various types of binary data such as datagrams, packets and the like. A transmission may also include analog signals.

“**Triggering Data**” generally refers to data that includes triggering information identifying one or more commands to execute. The triggering data and the command data may occur together in a single transmission or may be transmitted separately along a single or multiple communication links.

“**Troposphere**” generally refers to the lowest portion of the Earth’s atmosphere. The troposphere extends about 11 miles above the surface of the earth in the mid-latitudes, up to 12 miles in the tropics, and about 4.3 miles in winter at the poles.

“**Tropospheric scatter transmission**” generally refers to a form of sky-wave propagation in which one or more electromagnetic waves, such as radio waves, are aimed at the troposphere. While not certain as to its cause, a small amount of energy of the waves is scattered forwards to a receiving antenna. Due to severe fading problems, diversity reception techniques (e.g., space, frequency, and/or angle diversity) are typically used.

“**Wave Guide**” generally refers to a transmission line configured to guides waves such as electromagnetic waves occurring at any frequency along the electromagnetic spectrum. Examples include any arrangement of conductive or insulative material configured to transfer lower frequency electromagnetic radiation ranging along the electromagnetic spectrum from extremely low frequency to extremely high frequency waves. Others specific examples include optical fibers guiding high-frequency light or hollow conductive metal pipe used to carry high-frequency radio waves, particularly microwaves.

It should be noted that the singular forms "a", "an", "the", and the like as used in the description and/or the claims include the plural forms unless expressly discussed otherwise. For example, if the specification and/or claims refer to "a device" or "the device", it includes one or more of such devices.

It should be noted that directional terms, such as "up", "down", "top", "bottom", "fore", "aft", "lateral", "longitudinal", "radial", "circumferential", etc., are used herein solely for the convenience of the reader in order to aid in the reader's understanding of the illustrated embodiments, and it is not the intent that the use of these directional terms in any manner limit the described, illustrated, and/or claimed features to a specific direction and/or orientation.

While the invention has been illustrated and described in detail in the drawings and foregoing description, the same is to be considered as illustrative and not restrictive in character, it being understood that only the preferred embodiment has been shown and described and that all changes, equivalents, and modifications that come within the spirit of the inventions defined by following claims are desired to be protected. All publications, patents, and patent applications cited in this specification are herein incorporated by reference as if each individual publication, patent, or patent application were specifically and individually indicated to be incorporated by reference and set forth in its entirety herein.

CLAIMS

1. A system comprising:
 - a first communication node for sending a data transmission as an electromagnetic wave over a data transmission path using skywave propagation, wherein the data transmission path includes a reflection point where the electromagnetic wave of the data transmission is reflected by the ionosphere;
 - a second communication node for receiving the data transmission from the first communication node;
 - an atmospheric sensor configured to collect ionospheric data at the reflection point of the data transmission from the first communication node;
 - a transmission frequency model for determining an optimum working frequency at which to transmit the data transmission over the data transmission path; and,
 - wherein the transmission frequency model uses the ionospheric data measured by the atmospheric sensor as an input to determine the optimum working frequency.
- 5
- 10
- 15
2. The system of claim 1, wherein the atmospheric sensor includes an ionosonde.
3. The system of any preceding claim, wherein the atmospheric sensor is configured to collect weather condition data at the reflection point of the data transmission the first communication node; and,
- 20
4. The system of claim 3, wherein the transmission frequency model uses the weather condition data measured by the atmospheric sensor as an input to determine the optimum working frequency.
- 25
5. The system of any preceding claim, wherein the reflection point is located above an ocean and the atmospheric sensor is located on an oceanic structure.
6. The system of any preceding claim, wherein the data transmission path includes at least two reflection points and wherein a respective atmospheric sensor is configured to collect ionospheric data at each of the reflection points.
- 30
7. The system of any preceding claim,

wherein the first communication node is configured to operate in a broadcast mode to publicly broadcast content over the data transmission path; and

wherein the sensor is configured to monitor the degradation of the broadcast signal over the data transmission path.

5

8. The system of any preceding claim, wherein the atmospheric sensor is positioned directly below the reflection point.

9. The system of any preceding claim, wherein the transmission frequency model uses ionospheric data measured by the atmospheric sensor to encode a transmitted data signal.

10

10. The system of any preceding claim, wherein the transmission frequency model uses the ionospheric data measured by the atmospheric sensor to decode a transmitted data signal.

11. The system of any preceding claim, wherein the optimum working frequency is the frequency that provides the most consistent communication path via sky-wave propagation.

15

12. A method comprising:

determining the location of a reflection point of a radio wave during skywave propagation;

20

measuring atmospheric condition data at the reflection point using a sensor;

inputting the atmospheric condition data collected from the sensor into a transmission frequency model to determine an optimum working frequency for transmission of a data signal;

25

transmitting a data stream by skywave propagation at the optimum working frequency as determined by the transmission frequency model.

13. The method of claim 12, wherein the sensor measures ionospheric conditions at the reflection point.

30

14. The method of any of claims 12-13, wherein the sensor measures ionospheric height.

15. The method of any of claims 12-14, wherein the sensor is an ionosonde.

16. The method of any of claims 12-15, wherein the sensor measures weather conditions at the reflection point.
- 5 17. The method of any of claims 12-16, wherein the sensor measures ionospheric conditions and weather conditions at the reflection point.
18. The method of any of claims 12-17, wherein the sensor is positioned on an oceanic structure.
- 10 19. The method of any of claims 12-18, further comprising:
encoding the transmitted data stream based on atmospheric condition data collected from the sensor.
- 15 20. The method of any of claims 12-19, further comprising:
decoding the transmitted data stream based on atmospheric condition data collected from the sensor.
- 20 21. The method of any of claims 12-20, further comprising:
publicly broadcasting audio content as a digital broadcast signal;
monitoring the digital broadcast signal using the sensor to collect digital broadcast data;
inputting the digital broadcast data into the transmission frequency model.

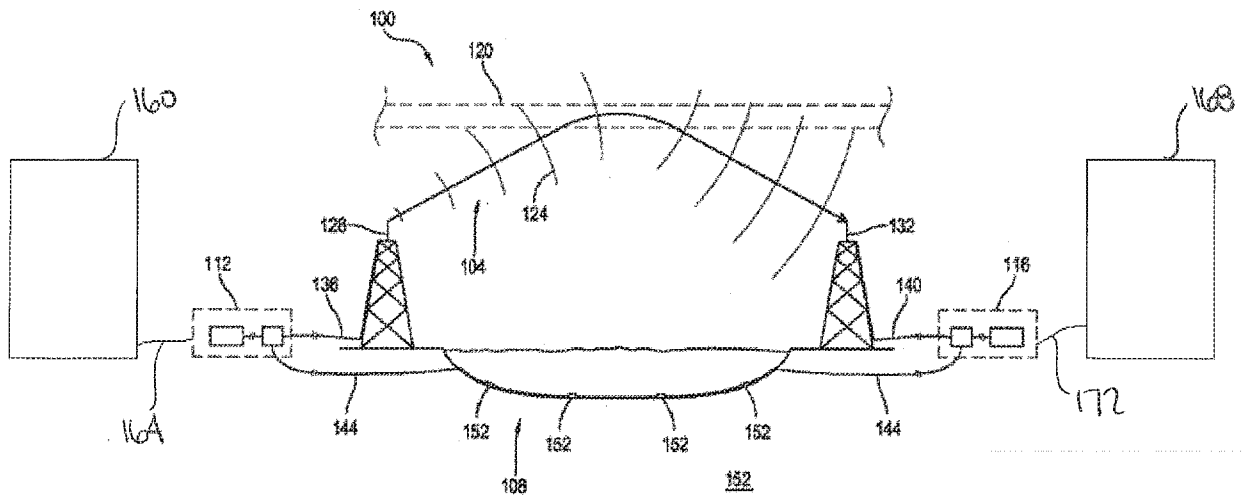

Fig. 1

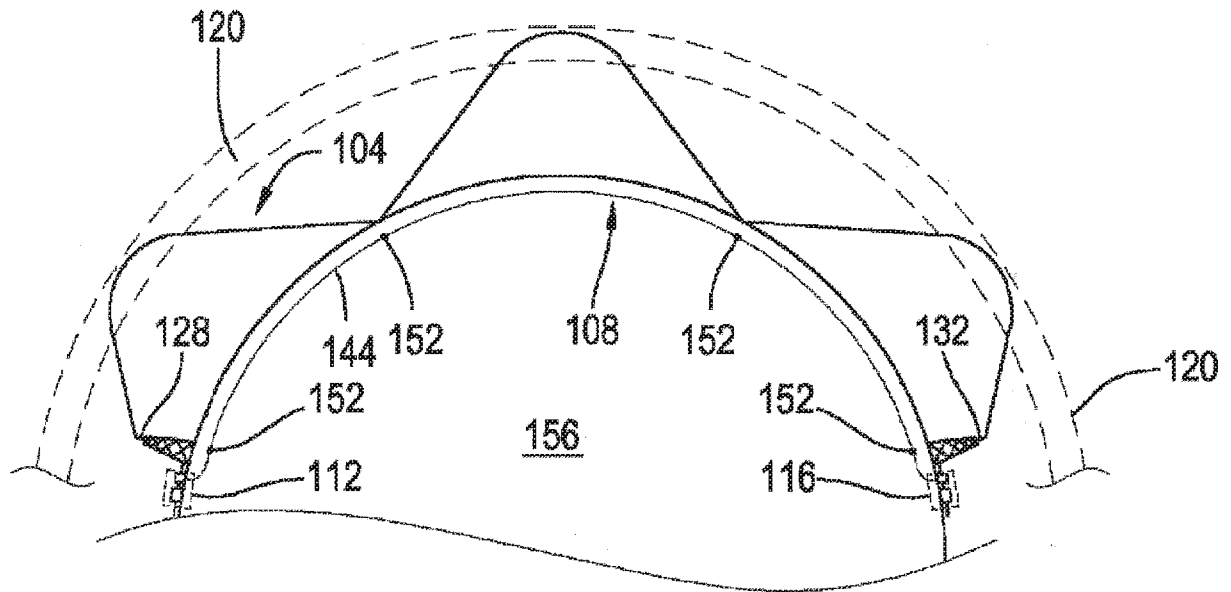

Fig. 2

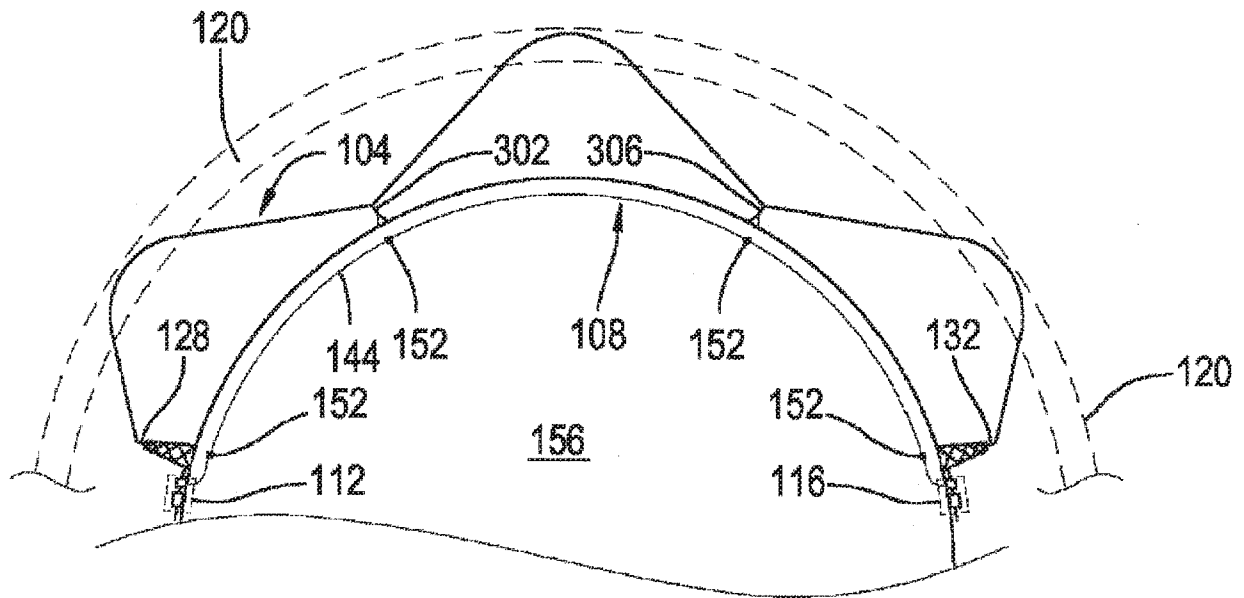

Fig. 3

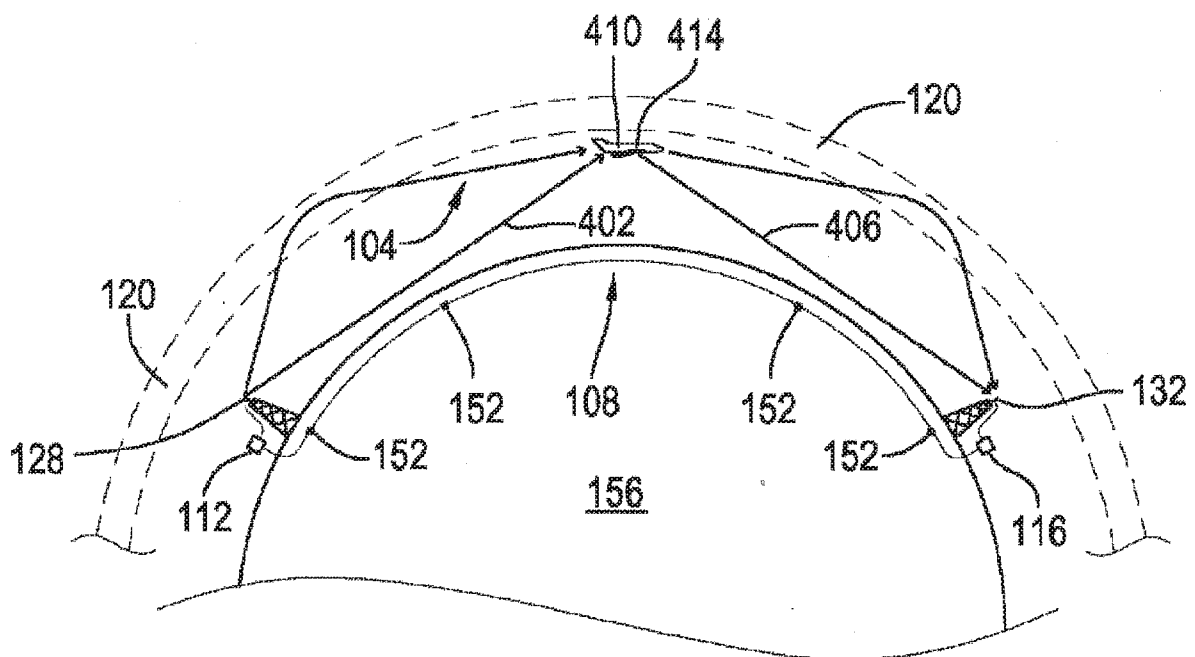

Fig. 4

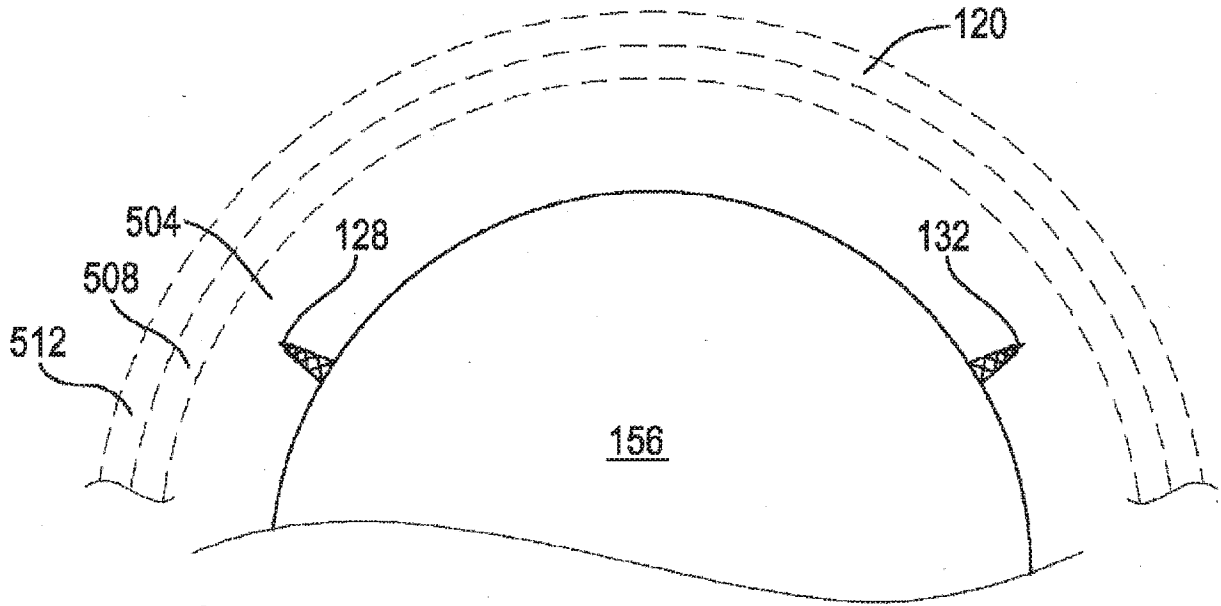

Fig. 5

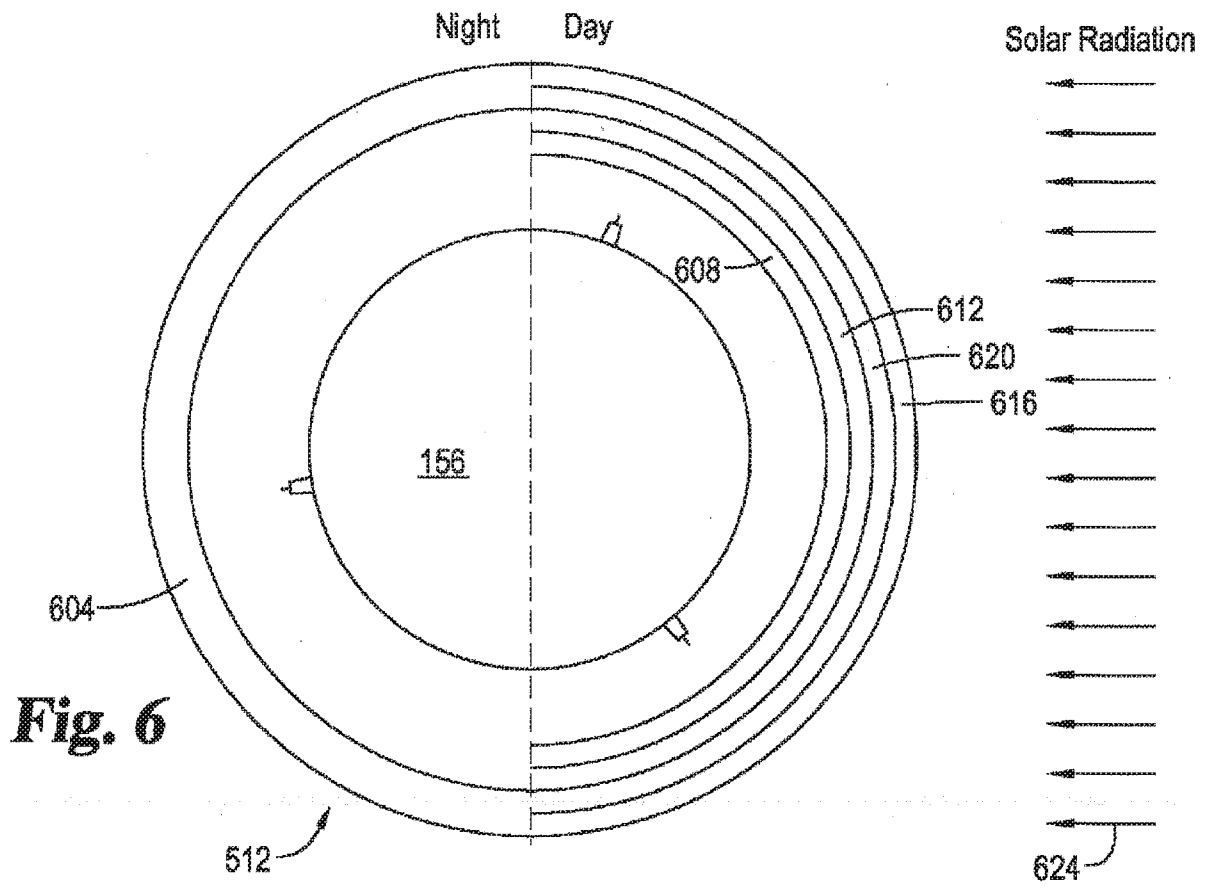

Fig. 6

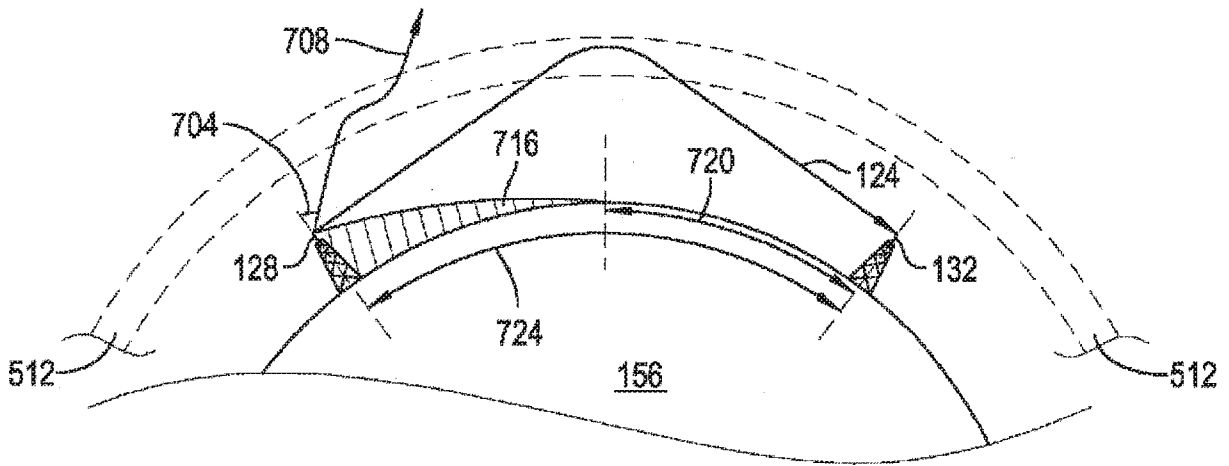

Fig. 7

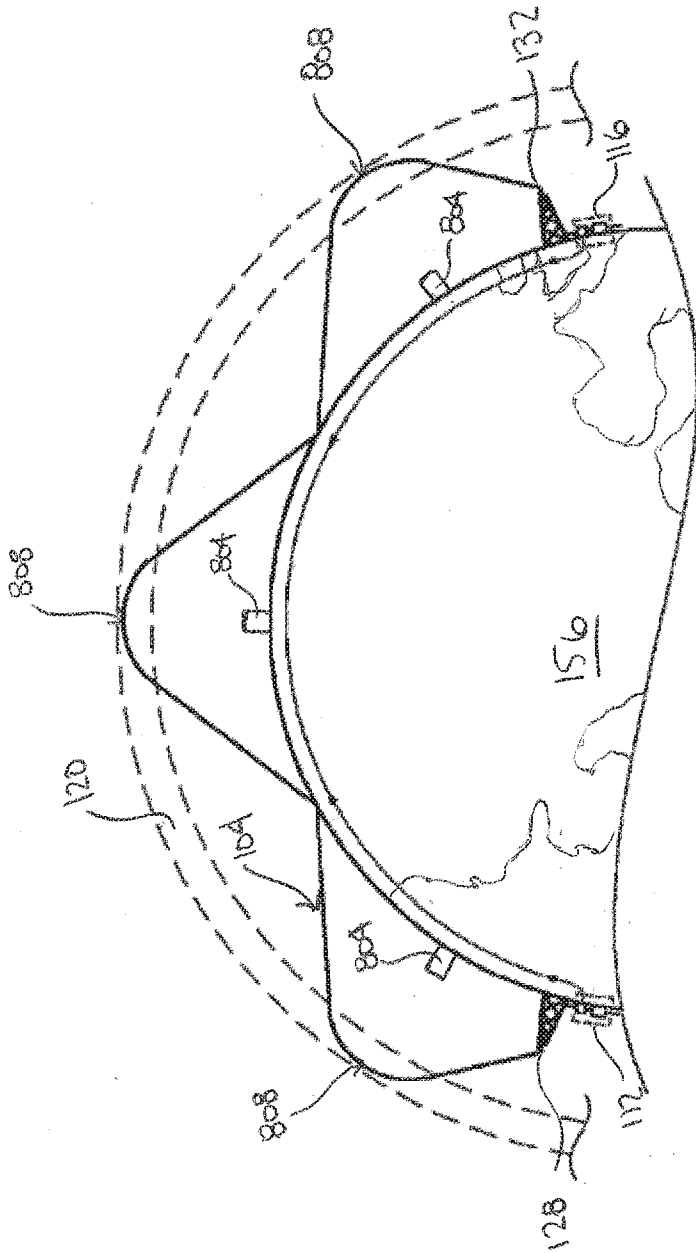

Fig. 8

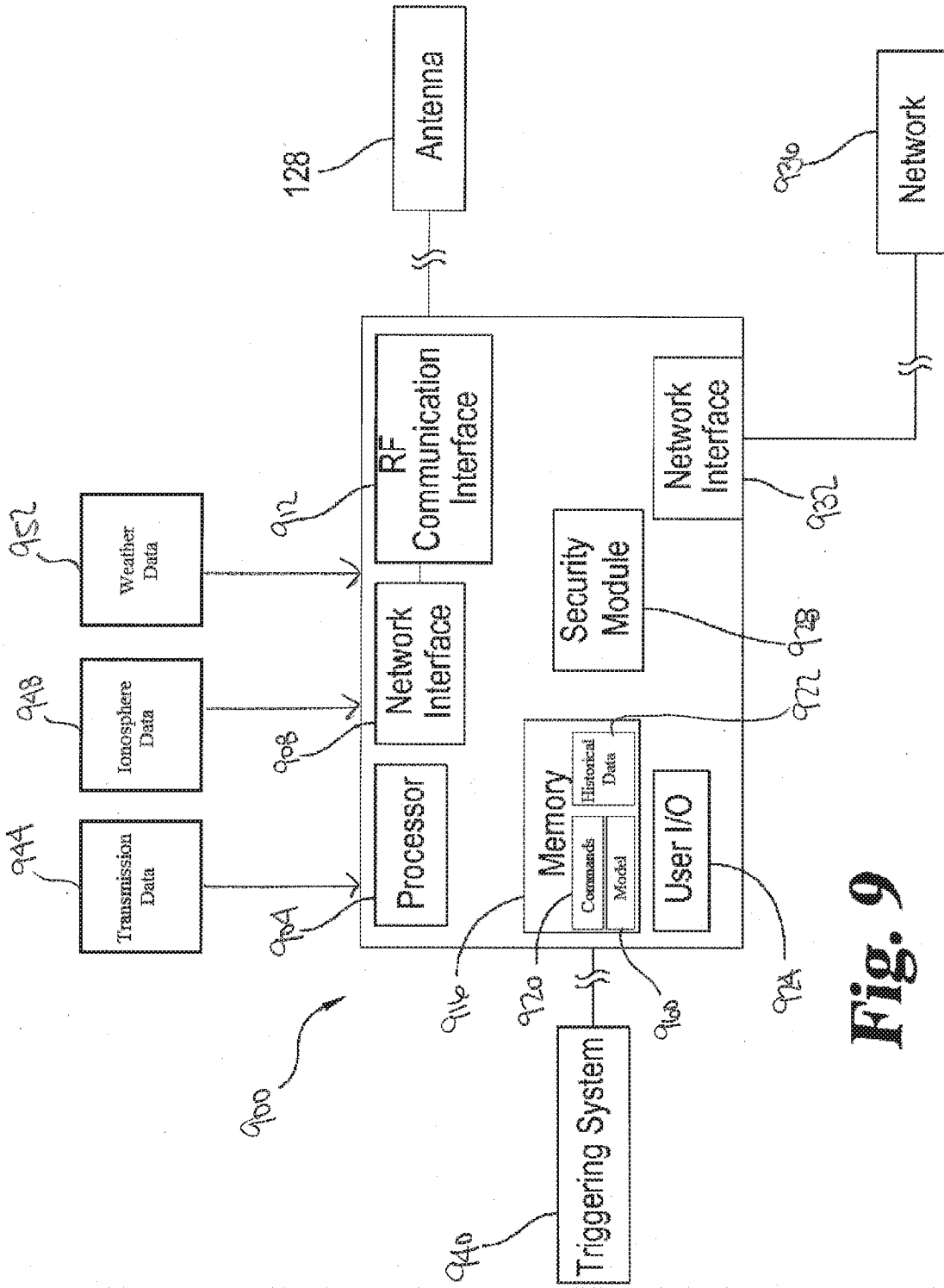

Fig. 9

1000

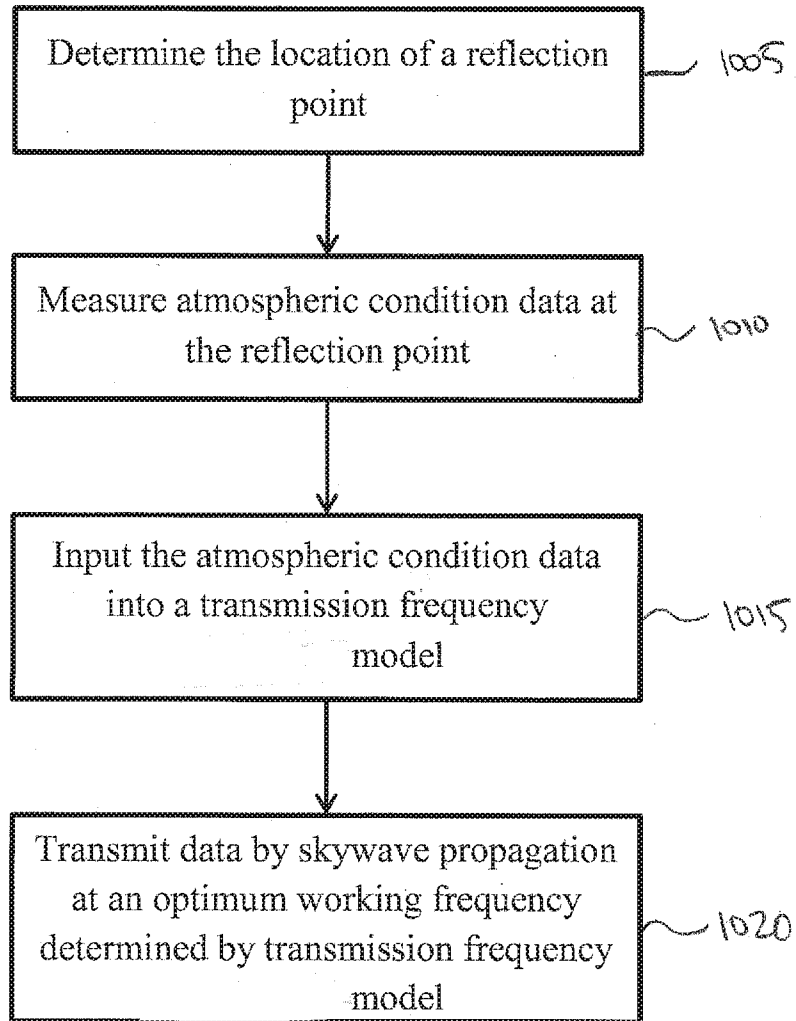

Fig. 10