

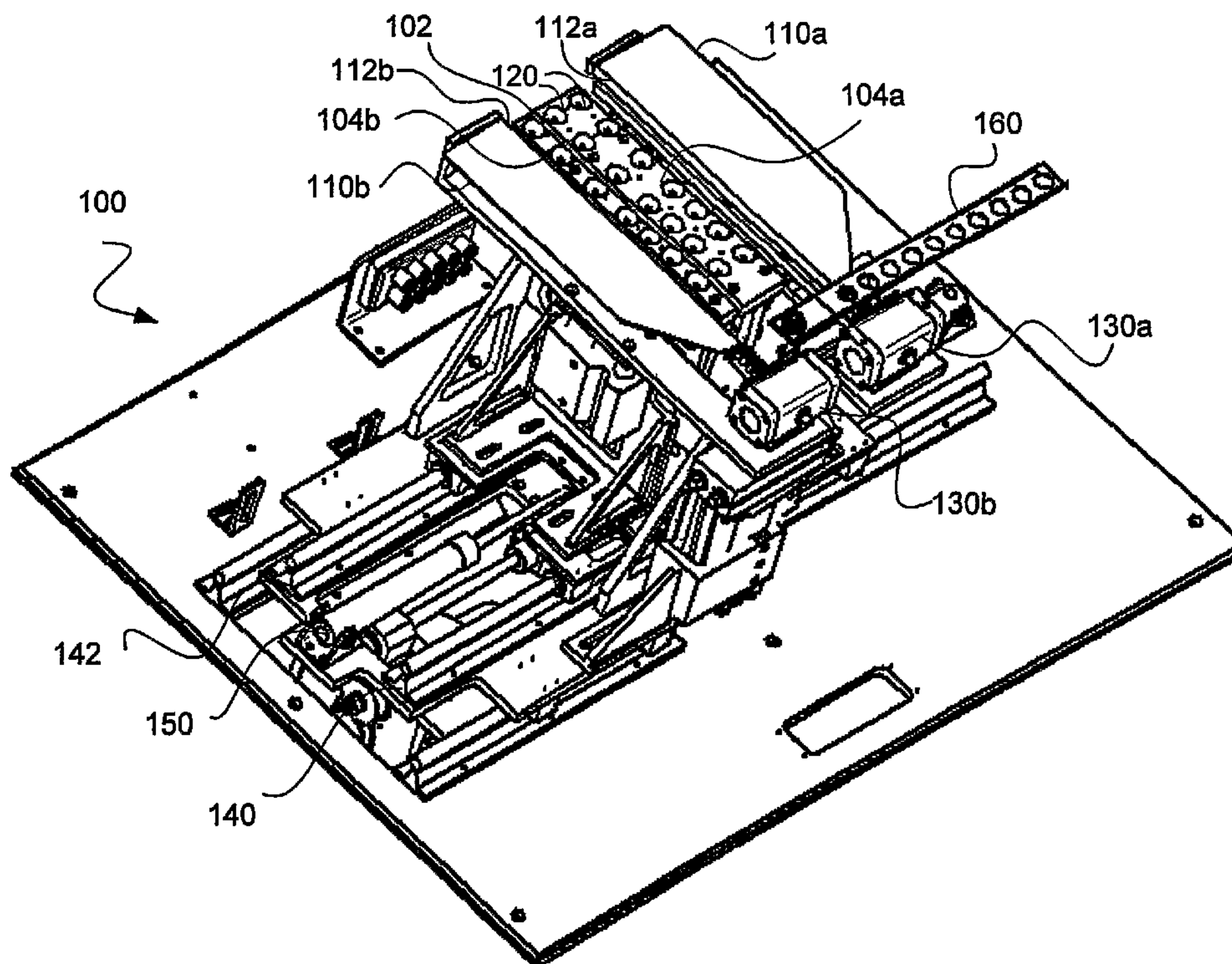

(86) Date de dépôt PCT/PCT Filing Date: 2002/01/30
 (87) Date publication PCT/PCT Publication Date: 2002/08/08
 (85) Entrée phase nationale/National Entry: 2003/07/30
 (86) N° demande PCT/PCT Application No.: US 2002/003106
 (87) N° publication PCT/PCT Publication No.: 2002/060678
 (30) Priorité/Priority: 2001/02/01 (09/775,539) US

(51) Cl.Int.⁷/Int.Cl.⁷ B31B 1/26, B65H 45/20, B65H 45/18,
B31F 1/08
 (71) Demandeur/Applicant:
HALLMARK CARDS INCORPORATED, US
 (72) Inventeur/Inventor:
HOOPER, DENNIS L., US
 (74) Agent: MBM & CO.

(54) Titre : POSTE DE PLIAGE REGLABLE POUR CARTES
 (54) Title: ADJUSTABLE FOLDING STATION FOR CARDS



(57) **Abrégé/Abstract:**

An adjustable card folding station (100) includes an adjustable vacuum bed and movable gates (110a, 110b). The vacuum bed includes at least two sections (104a, 104b) that are movable with respect to each other to accommodate cards of different widths. Each section of the vacuum bed further includes multiple suction cups (120), each of which is individually connected to a vacuum supply. The vacuum supply independently controls each suction cup (120) so that vacuum can be applied to selected or all suction cups such that cards of different lengths can be accommodated. The movable gates (110a, 110b) are pivotally mounted with respect to the vacuum bed and operated by motors (130a, 130b) to pivot 180 degrees from open to closed positions to fold the cards.

(12) INTERNATIONAL APPLICATION PUBLISHED UNDER THE PATENT COOPERATION TREATY (PCT)

CORRECTED VERSION

(19) World Intellectual Property Organization
International Bureau(43) International Publication Date
8 August 2002 (08.08.2002)

PCT

(10) International Publication Number
WO 02/060678 A3

- (51) International Patent Classification⁷: B31B 1/26, B31F 1/08, B65H 45/18, 45/20
- (74) Agent: JOBE, Jonathan, E.; Pillsbury Winthrop LLP, 50 Fremont Street, P.O. Box 7880, San Francisco, CA 94105 (US).
- (21) International Application Number: PCT/US02/03106
- (22) International Filing Date: 30 January 2002 (30.01.2002)
- (25) Filing Language: English
- (26) Publication Language: English
- (30) Priority Data:
09/775,539 1 February 2001 (01.02.2001) US
- (71) Applicant: HALLMARK CARDS INCORPORATED [US/US]; Mail Drop 339, P.O. Box 419126, Kansas City, MO 64141-6126 (US).
- (72) Inventor: HOOPER, Dennis, L.; 1224 Southwest Pacific Drive, Lee's Summit, MO 64081 (US).
- (81) Designated States (*national*): AE, AG, AL, AM, AT, AU, AZ, BA, BB, BG, BR, BY, BZ, CA, CH, CN, CO, CR, CU, CZ, DE, DK, DM, DZ, EC, EE, ES, FI, GB, GD, GE, GH, GM, HR, HU, ID, IL, IN, IS, JP, KE, KG, KP, KR, KZ, LC, LK, LR, LS, LT, LU, LV, MA, MD, MG, MK, MN, MW, MX, MZ, NO, NZ, OM, PH, PL, PT, RO, RU, SD, SE, SG, SI, SK, SL, TJ, TM, TN, TR, TT, TZ, UA, UG, UZ, VN, YU, ZA, ZM, ZW.
- (84) Designated States (*regional*): ARIPO patent (GH, GM, KE, LS, MW, MZ, SD, SL, SZ, TZ, UG, ZM, ZW), Eurasian patent (AM, AZ, BY, KG, KZ, MD, RU, TJ, TM), European patent (AT, BE, CH, CY, DE, DK, ES, FI, FR, GB, GR, IE, IT, LU, MC, NL, PT, SE, TR), OAPI patent (BF, BJ, CF, CG, CI, CM, GA, GN, GQ, GW, ML, MR, NE, SN, TD, TG).

[Continued on next page]

(54) Title: ADJUSTABLE FOLDING STATION FOR CARDS

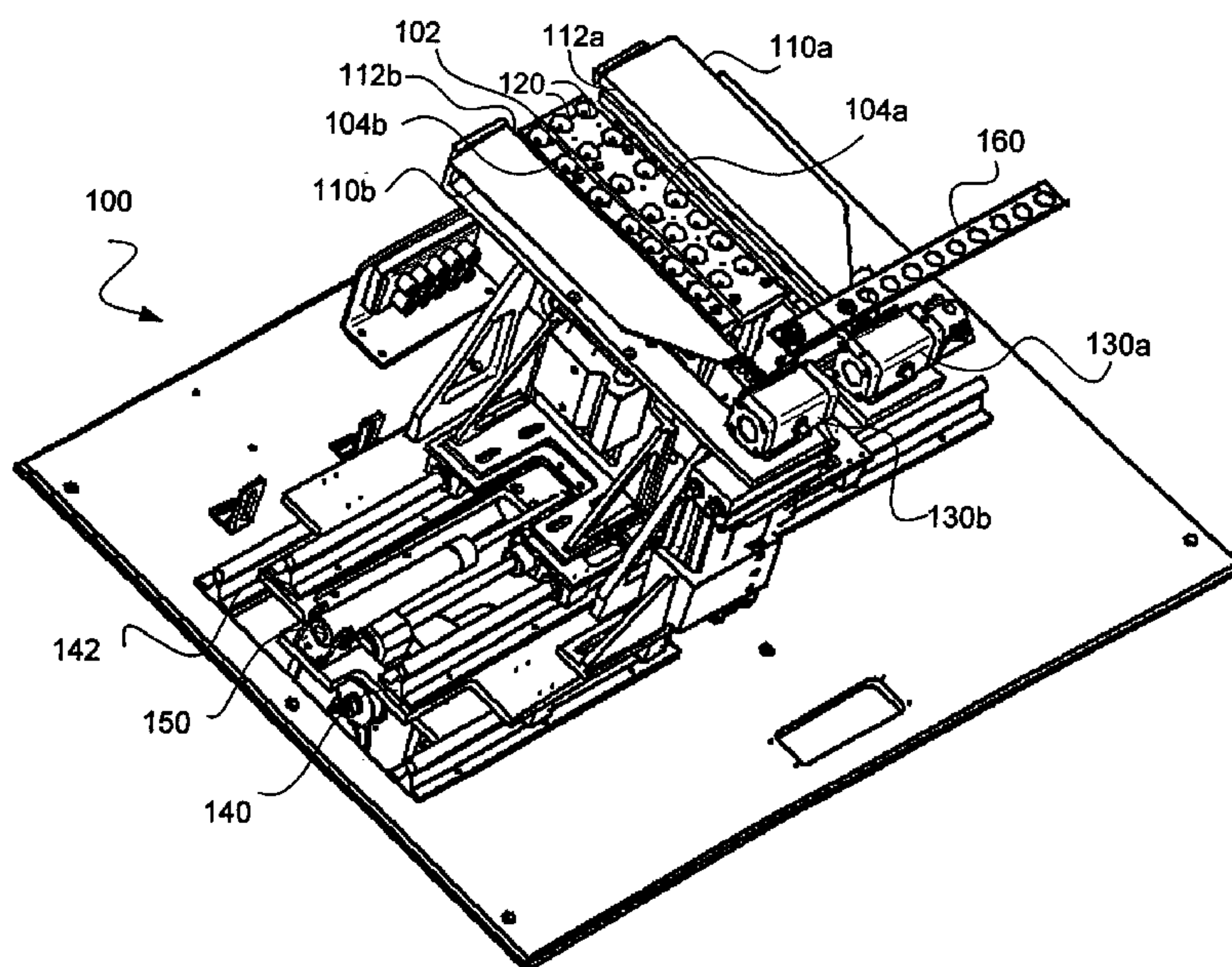

(57) Abstract: An adjustable card folding station (100) includes an adjustable vacuum bed and movable gates (110a, 110b). The vacuum bed includes at least two sections (104a, 104b) that are movable with respect to each other to accommodate cards of different widths. Each section of the vacuum bed further includes multiple suction cups (120), each of which is individually connected to a vacuum supply. The vacuum supply independently controls each suction cup (120) so that vacuum can be applied to selected or all suction cups such that cards of different lengths can be accommodated. The movable gates (110a, 110b) are pivotally mounted with respect to the vacuum bed and operated by motors (130a, 130b) to pivot 180 degrees from open to closed positions to fold the cards.



WO 02/060678 A3

WO 02/060678 A3



Published:

— *with international search report*

(88) Date of publication of the international search report:

7 November 2002

(48) Date of publication of this corrected version:

27 December 2002

(15) Information about Correction:

see PCT Gazette No. 52/2002 of 27 December 2002, Section II

For two-letter codes and other abbreviations, refer to the "Guidance Notes on Codes and Abbreviations" appearing at the beginning of each regular issue of the PCT Gazette.

ADJUSTABLE FOLDING STATION FOR CARDS

FIELD OF THE INVENTION

The present invention relates generally to an adjustable folding station, and
5 more particularly to a method and apparatus for folding cards of different sizes, shapes,
and styles.

DESCRIPTION OF THE PRIOR ART

Social expression cards or greeting cards are manufactured and sold in a variety
10 of sizes, shapes, and styles to provide consumers a wide selection. These cards are
most popular during holidays and special occasions such as Christmas, Valentine's
Day, birthday, anniversary, and the like. As can be expected, the card industry is and
will continue to be a very lucrative and thriving industry.

During the manufacturing process, cards can be folded in different styles. For
15 example, FIGS. 1-3 illustrate various folds that are common in the industry. FIG. 1
illustrates an example of a regular fold of a card. As illustrated, a card 2 is evenly
divided along a score line 4 to form two panels 6a, 6b. A regular fold occurs when the
panel 6b is folded over the panel 6a (or vice versa) along the score line 4. The score
line 4 can be creased or indented prior to folding one panel over the other. The regular
20 fold is one of the most commonly used folds in the card industry.

Next, FIG. 2 illustrates an example of a gate fold of a card. As illustrated, a
card 12 is evenly divided along a pair of score lines 14a, 14b to form three panels 16a,
16b, 16c. A gate fold occurs when the first outer panel 16c is first folded over the
center panel 16b along the score line 14b. Thereafter, the second outer panel 16a is

folded over panels 16b, 16c along the other score line 14a. Again, the score lines 14a, 14b can be creased or indented prior to folding the panels over each other.

Alternatively, the card can be folded using a Z-fold method. A Z-fold occurs when the panels 16b, 16c are first folded over the panel 16a along the score line 14a. Thereafter, the panel 16c is back folded over panels 16b, 16a along the score line 14b to complete the Z-fold. FIG. 3 illustrates a side view of the Z-fold of the card 22.

Conventional folding stations that are used in the industry for folding cards will now be described. One conventional folding station is known as a buckle folder. A buckle folder pinches a creased card between two rollers and forces an end of the card against a stop. As the card continues to move against the stop, the card begins to buckle. The mechanical weakness provided by the crease allows the card to buckle at a predetermined point or the score line. As the card buckles outward, a nip roller grabs the card at the score line and completes the fold. Another conventional folding station is a belt folder, which uses a variety of rods and guides to move a panel of the card into its folded position as the card is pulled along by a series of opposing belts.

Although the conventional folding stations described above are widely used and accepted in the card industry, problems remain. For instance, conventional folding stations are not well suited to handle cards with different dimensions and styles. In other words, conventional folding stations are not flexible enough to fold cards of different sizes and shapes and cannot fold them using different folding techniques. Accordingly, there is a great need for an adjustable apparatus for folding cards of different sizes, shapes, and styles.

SUMMARY OF THE INVENTION

It is an object of the present invention to provide an adjustable folding station for folding cards of different sizes, shapes, and styles.

It is another object of the present invention to provide a method and apparatus
5 that can fold cards of different sizes, shapes and styles with minimal adjustments.

It is yet another object of the present invention to provide a method and apparatus implementing an adjustable vacuum bed and individually controlled vacuum suction cups for folding cards of different sizes.

It is another object of the present invention to provide a method and apparatus
10 implementing separately actuated gates for folding cards of different styles.

These and other objects of the present invention are obtained by providing a card folding station having an adjustable vacuum bed and moveable gates. The vacuum bed includes at least two sections that are mounted for horizontal movement back and forth with respect to each other to accommodate cards of different widths.
15 Each section of the vacuum bed includes multiple suction cups, each of which is individually connected to a vacuum supply. The vacuum supply independently controls each suction cup so that vacuum can be applied to selected or all suction cups such that cards of different lengths can be accommodated. The movable gates are pivotally mounted with respect to the vacuum bed and operated by motors to pivot 180 degrees
20 from open to closed positions. During operation, a card (or cards) is placed on the vacuum bed and held therein as one or both gates are sequentially actuated to fold the card.

BRIEF DESCRIPTION OF THE DRAWINGS

These and other objects and advantages of the present invention will become apparent and more readily appreciated from the following detailed description of the presently preferred exemplary embodiments of the invention taken in conjunction with
5 the accompanying drawings, of which:

FIG. 1 illustrates a top view of a regular fold of a card;

FIG. 2 illustrates a top view of a gate fold of a card;

FIG. 3 illustrates a side view of a Z-fold of a card;

FIG. 4 illustrates a perspective view of an adjustable folding station in
10 accordance with the present invention;

FIG. 5 illustrates a top view of the adjustable folding station of FIG. 4 in accordance with the present invention;

FIG. 6 illustrates a regular folding process of a card using the adjustable folding station in accordance with the present invention;

15 FIG. 7 illustrates a gate folding process of a card using the adjustable folding station in accordance with the present invention; and

FIG. 8 illustrates a Z-folding process of a card using the adjustable folding station in accordance with the present invention.

20 DETAILED DESCRIPTION OF THE PREFERRED EMBODIMENTS

The present invention will now be described in greater detail, which will serve to further the understanding of the preferred exemplary embodiments of the present invention. As described elsewhere herein, various refinements and substitutions of the various embodiments are possible based on the principles and teachings herein.

The preferred embodiments of the present invention will now be described with reference to FIGS. 4-8, wherein like components, steps, etc. are designated by like reference numerals throughout the various figures. Further, specific details and parameters are provided herein and are intended to be explanatory rather than limiting.

5 The present invention relates to a method and apparatus for folding cards of different sizes, shapes, and styles. The apparatus is a card folding station having an adjustable vacuum bed and moveable gates. The vacuum bed is adjustable to accommodate cards of different widths. The vacuum bed includes multiple suction cups, which are individually connected to a vacuum supply. The vacuum supply
10 independently controls each suction cup so that vacuum can be applied to all or selected suction cups to accommodate cards of different lengths. The movable gates are pivotally mounted with respect to the vacuum bed and operated by motors to pivot 180 degrees from open to closed positions to fold the cards. The presently preferred embodiments will now be described with reference to a card, although other folding
15 items can be used in the present invention.

FIG. 4 illustrates a perspective view and FIG. 5 illustrates a top view of an adjustable folding station in accordance with the present invention. The folding station
100 includes a vacuum bed 102 and movable or folding gates 110a, 110b. One gate 110a is preferably fixed in its position, whereas the other gate 110b is adjustable in the
20 y-direction using a servo driver (not shown) or other driving mechanism. The gates 110a, 110b as illustrated in FIGS. 4-5 are shown in their open positions and can rotate around the x-axis about its ends 112a, 112b, respectively. When the gates 110a, 110b are fully rotated 180 degrees toward the vacuum bed 102, the gates 110a, 110b are in their closed positions. The gates 110a, 110b are rotated or pivoted using motors such

as a first gate actuator 130a and a second gate actuator 130b, respectively. Since gate actuators 130a, 130b are well known in the art, they will not be described in great detail herein. In other embodiments, different devices than the gate actuators 130a, 130b can be used to rotate the gates 110a, 110b from their open to closed positions and vice versa. The gate actuators 130a, 130b are connected to gates 110a, 110b, respectively, via shafts, rods, and the like (not shown) and provide the necessary torque to rotate the gates 110a, 110b. In addition, a Z-fold gate 160 may be used to assist in folding the card using the Z-fold process, which is described in greater detail later herein.

10 The vacuum bed 102 includes two sections, a fixed bed section 104a and an adjustable bed section 104b. In other embodiments, the bed 104a can be adjustable and the bed 104b can be fixed. Both the fixed bed 104a and the adjustable bed 104b include multiple suction cups 120 along the x and y directions of the beds 104a, 104b. The suction cups 120 are individually connected to a vacuum supply (not shown). The vacuum supply is used to independently control each suction cup so that vacuum can be applied to selected or all suction cups 120, depending on the length of the card.

As is well known in the industry, the suction cups 120 are used to secure the card within the vacuum bed 102. The suction cups 120 are generally made from any suitable material such as rubber, polymer, or other materials that are capable of securing the card on the vacuum bed 102. Depending on the length of the card, vacuum is provided to selected suction cups 120 for securing the card. For example, if the length of the card extends along the entire length (i.e, x-direction) of the vacuum bed 102, then the vacuum supply can provide vacuum to all the suction cups 120. Alternatively, if the length of the card is relatively short, then the vacuum supply can

provide vacuum to selected suction cups 120 that are covered by the card when the card is positioned on the vacuum bed 102. In this manner, the folding station 100 can accommodate cards with different lengths by way of supplying vacuum to selected or all suction cups 120.

5 The folding station 100 can also be used to accommodate cards with different widths using the adjustable gate 110b and the adjustable vacuum bed 104b. As illustrated, the adjustable gate 110b and the adjustable vacuum bed 104b are connected to each other and a pair of linear bearings 140, 142. In another embodiment, the adjustable gate 110b and the adjustable vacuum bed 104b may not be connected
10 together and move about independently. A mechanism such as a ball screw 150 can be used to drive the adjustable gate 110b and the adjustable vacuum bed 104b in the y-direction. In this manner, the vacuum bed 102 can accommodate cards of different widths by adjusting the gate 110b and the vacuum bed 104b. As a result, cards of different widths and lengths can be secured and folded using the folding station 100. It
15 should also be noted that the widths and the lengths of the cards vary depending on the card manufacturers' specifications.

 Although the present invention describes one ball screw 150 and a pair of linear bearings 140, 142 to adjust the gate 110b and bed 104b in the y-direction, it is understood that any suitable number of ball screws and linear bearings, or a mechanism
20 that does not rely on a ball screw and/or linear bearings are intended to be within the scope and spirit of the present invention. Also, although only two vacuum bed sections 104a, 104b and two gates 110a, 110b are illustrated herein, it is understood that in other embodiments more or less than two bed sections and gates can be used.

In addition, other similar components/devices may be substituted for the ones described above.

Methods for folding the cards in different styles will now be described with reference to FIGS. 6-8. Reference will also be made concurrently to FIGS. 1-5 for a more complete understanding of the methods according to the present invention.

FIG. 6 illustrates a regular folding process of a card using the adjustable folding station in accordance with the present invention. During operation, the vacuum bed 104b and the gate 110b are adjusted, depending on the width of the card, before placing the card thereon in step 600. Thereafter, the card 2 (or multiple cards) is placed on the vacuum bed 102 and the gate 110a (or gate 110b) in step 602. In other words, one panel 6a of the card 2 is placed on the vacuum bed 102 and the other panel 6b is placed on the gate 110a (or gate 110b). The score line 4 on the card 2 is preferably positioned directly above the gate edge 112a (or gate edge 112b). Next, the supply vacuum actuates the vacuum to all or selected suction cups 120, depending on the length of the card, to secure the card therein in step 604. In step 606, the gate 110a (or gate 110b) is pivoted or rotated 180 degrees from its open to closed position using the gate actuator 130a (or gate actuator 130b) to fold the card, resulting in the completion of the regular fold.

FIG. 7 illustrates a gate folding process of a card using the adjustable folding station in accordance with the present invention. During operation, the vacuum bed 104b and the gate 110b are adjusted, depending on the length of the card, prior to placing the card thereon in step 700. Thereafter, the card 12 (or multiple cards) is placed on the vacuum bed 102 and the gates 110a, 110b in step 702. The center panel 16b is placed on the vacuum bed 102 and the outer panels 16a, 16c are placed on the

gates 110a, 110b, respectively. The score lines 14a, 14b are preferably positioned directly above the gate edges 112a, 112b, respectively. Next, the supply vacuum actuates the vacuum to all or selected suction cups 120, depending on the length of the card, to secure the card therein in step 704. In step 706, the gate 110a is pivoted or rotated 180 degrees using the gate actuator 130a to fold the panel 16a over the panel 16b. Next, in step 708, the gate 110b is likewise pivoted or rotated 180 degrees using the gate actuator 130b to fold the panel 16c over panels 16b, 16a, resulting in the completion of the gate fold.

FIG. 8 illustrates a Z-folding process of a card using the adjustable folding station in accordance with the present invention. During operation, the vacuum bed 104b and the gate 110b are adjusted, depending on the length of the card, before placing the card thereon in step 800. Thereafter, the card 22 (or multiple cards) is placed on the vacuum bed 102 and gate 110a in step 802. In other words, the center panel 16b is placed on the gate 110a and the first outer panel 16a is placed on the vacuum bed 102. The score line 14a is preferably positioned directly above the gate edge 112a. Next, the supply vacuum actuates the vacuum to all or selected suction cups 120, depending on the length of the card, to secure the card therein in step 804. In step 806, the gate 110a is pivoted or rotated 180 degrees using the gate actuator 130a to fold the center and second end panels 16b, 16c over the first end panel 16a. Next, in step 808, the gate 110b is likewise pivoted or rotated 180 degrees using the gate actuator 130b to back fold the second end panel 16c over the first end and center panels 16a, 16b, resulting in the completion of the Z-fold. Alternatively, before back folding the second end panel 16c, the Z-fold gate 160 can be rotated counter-clockwise about 90 degrees (i.e., perpendicular to its position shown in FIGS. 4-5) to

secure the card 22. As shown, the Z-fold gate 160 is positioned in a slightly higher plane than the gates 110a, 110b. In this manner, the Z-fold gate 160 not only secures the card 22, but assists the gate 110b in back folding the second end panel 16c over the first end and center panels 16a, 16b.

5 It is to be understood that in the foregoing discussion and appended claims, the terms "card" include, but are not limited to, greeting cards, invitations, letters, flyers, etc. Also, it is understood that the folding gates can rotate about or approximately 180 degrees (or about 90 degrees for Z-fold gate) to perform the folding functions described herein. Although various preferred embodiments of the present invention
10 have been disclosed for illustrative purposes, those skilled in the art will appreciate that various modifications, additions and/or substitutions are possible without departing from the scope and spirit of the present invention as disclosed in the claims.

 In the previous descriptions, numerous specific details and examples are set forth such as specific components, devices, steps, folds, cards, etc., to provide a
15 thorough understanding of the present invention. However, as one having ordinary skill in the art would recognize, the present invention can be practiced without resorting to the details and examples specifically set forth. Those skilled in the art will readily appreciate that many modifications of the exemplary embodiments are possible without materially departing from the novel teachings and advantages of this invention.

What is claimed:

1. A card folding station for accommodating a card having a width and a length, comprising:
 - a vacuum bed having an adjustable bed section and a fixed bed section, the adjustable bed section and the fixed bed section having suction cups for securing the card;
 - a pair of rotatable gates, wherein the first gate is fixed and the second gate is adjustable;
 - a pair of gate actuators, each actuator connected to one of the pair of gates;
 - a vacuum supply connected to the suction cups for selectively actuating some or all of the suction cups depending on the length of the card; and
 - a pair of linear bearings and a ball screw connected to the adjustable bed section and/or the second gate.
2. A card folding station according to claim 1, wherein the second gate is connected to the adjustable bed section.
3. A card folding station according to claim 1, wherein the pair of linear bearings and the ball screw are used to move the second gate and the adjustable bed in a linear direction.
4. A card folding station according to claim 1, wherein the pair of rotatable gates are adapted to be rotated about 180 degrees.

5. A card folding station according to claim 1 further comprising a Z-fold gate for securing the card during a Z-fold process.

6. A card folding station according to claim 5, wherein the Z-fold gate is
5 adapted to be rotated about 90 degrees.

7. A card folding station according to claim 1, wherein the suction cups comprise of materials such as rubber and polymer.

8. A card folding station for accommodating a card having a width and a
10 length, comprising:

a vacuum bed having an adjustable bed section and a fixed bed section, the adjustable bed section and the fixed bed section having suction cups;

a pair of gates, wherein the first gate is fixed, and the second gate is adjustable;
15 means for rotating the pair of gates;

means for selectively supplying vacuum to some or all of the suction cups depending on the length of the card; and

means for moving the adjustable bed section and/or the second gate in a linear direction to accommodate the width of the card.

20

9. A card folding station according to claim 8, wherein the second gate is connected to the adjustable bed section.

10. A card folding station according to claim 8, wherein the means for rotating the pair of gates comprises one or more gate actuators.

11. A card folding station according to claim 8, wherein the means for
5 selectively supplying vacuum comprises a vacuum supply connected to the suction cups.

12. A card folding station according to claim 8, wherein the means for moving the adjustable bed section and/or the second gate comprises a pair of linear
10 bearings and a ball screw.

13. A card folding station according to claim 8 further comprising a Z-fold gate for securing the card during a Z-fold process.

14. A method of securing a card having a width and length on a folding
15 station, the station having a fixed gate, a fixed vacuum bed, an adjustable gate, an adjustable vacuum bed, and suction cups placed on the vacuum beds, the method comprising:

adjusting the adjustable gate and/or the adjustable vacuum bed in a linear
20 direction to accommodate the width of the card;

placing the card on the beds and one or both the gates; and

selectively supplying vacuum to some or all of the suction cups depending on the length of the card.

15. A method according to claim 14 further comprising adjusting the adjustable gate and/or the adjustable vacuum bed using a pair of linear bearings and a ball screw.

5 16. A method of folding a card having a width, a length, and panels on a folding station, the station having a fixed gate, a fixed vacuum bed, an adjustable gate, an adjustable vacuum bed, and suction cups placed on the vacuum beds, the method comprising:

adjusting the adjustable gate and/or the adjustable vacuum bed in a linear
10 direction to accommodate the width of the card;
placing the card on the beds and one or both the gates;
selectively supplying vacuum to some or all of the suction cups depending on
the length of the card to secure the card; and
sequentially rotating one or both gates to fold one or more panels over each
15 other.

17. A method according to claim 16 further comprising adjusting the adjustable gate and/or the adjustable vacuum bed using a pair of linear bearings and a ball screw.

20

18. A method according to claim 16, wherein the placing step further comprises positioning a first panel of the card on the beds and a second panel of the card on one gate for a regular folding process.

19. A method according to claim 18, wherein the sequentially rotating step comprises rotating the one gate about 180 degrees to fold the second panel over the first panel.

5 20. A method according to claim 16, wherein the placing step further comprises positioning a center panel of the card on the beds and the first and second end panels of the card on each gate, respectively, for a gate folding process.

21. A method according to claim 20, wherein the sequentially rotating step
10 comprises:

first rotating one gate about 180 degrees to fold the first end panel over the center panel; and

second rotating the other gate about 180 degrees to fold the second end panel over the first end and center panels.

15

22. A method according to claim 16, wherein the placing step further comprises positioning a first end panel of the card on the beds and a center panel of the card on one gate for a Z-folding process.

23. A method according to claim 22, wherein the sequentially rotating step
20 comprises:

first rotating the one gate about 180 degrees to fold the center panel over the first end panel, whereby a second end panel is positioned on the other gate; and

second rotating the other gate about 180 degrees to fold the second end panel over the first end and center panels.

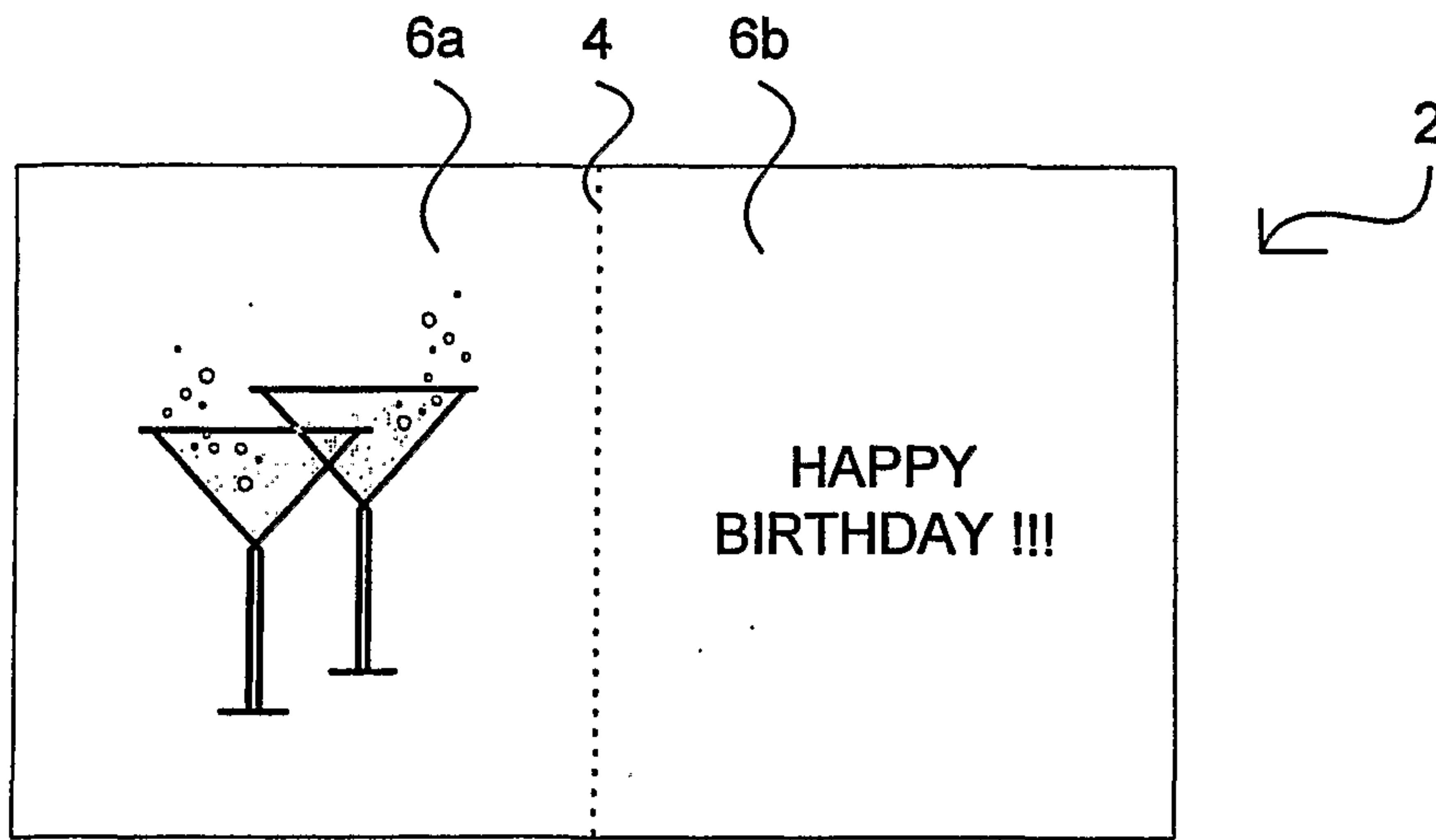

FIG. 1

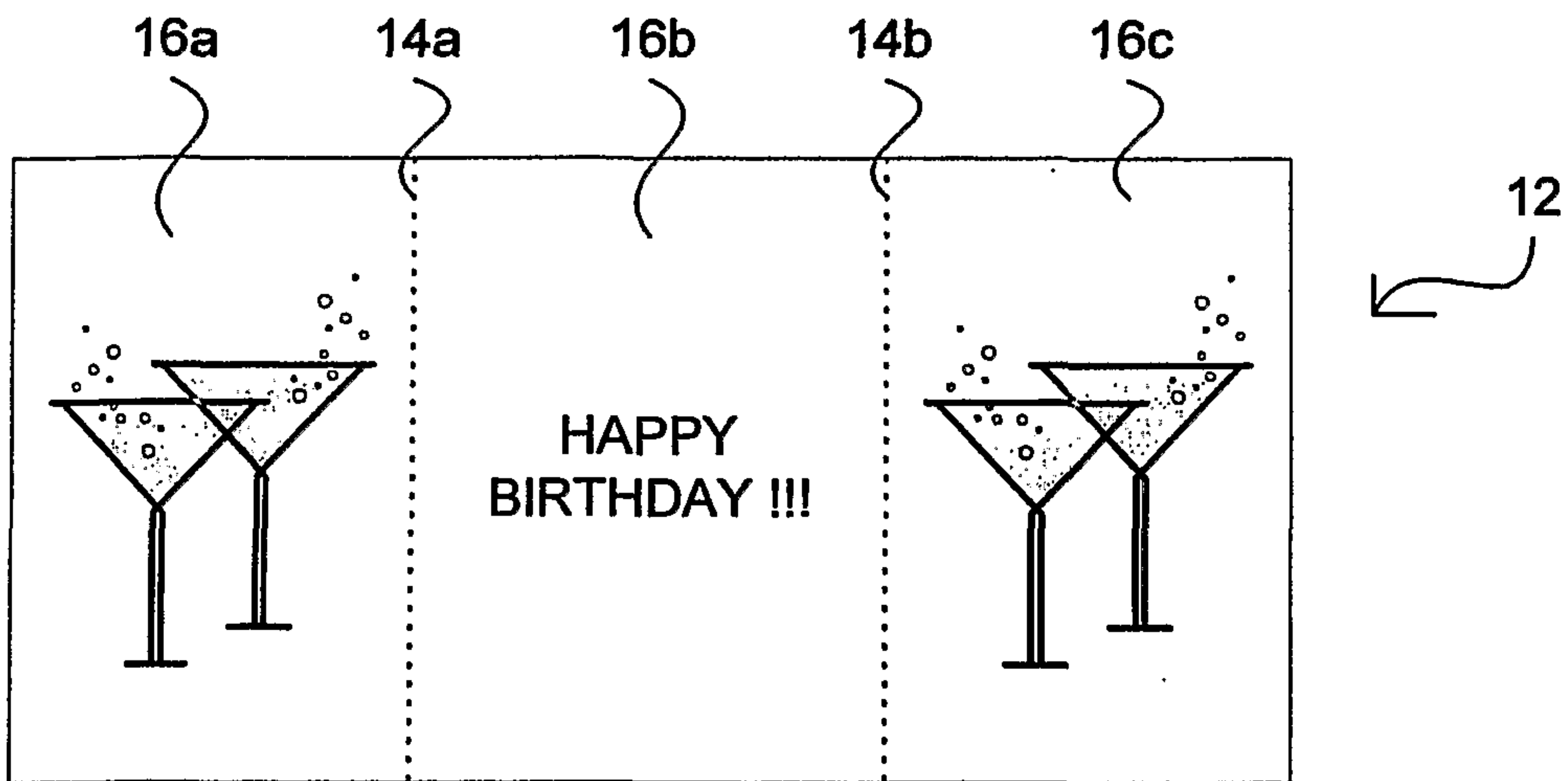

FIG. 2

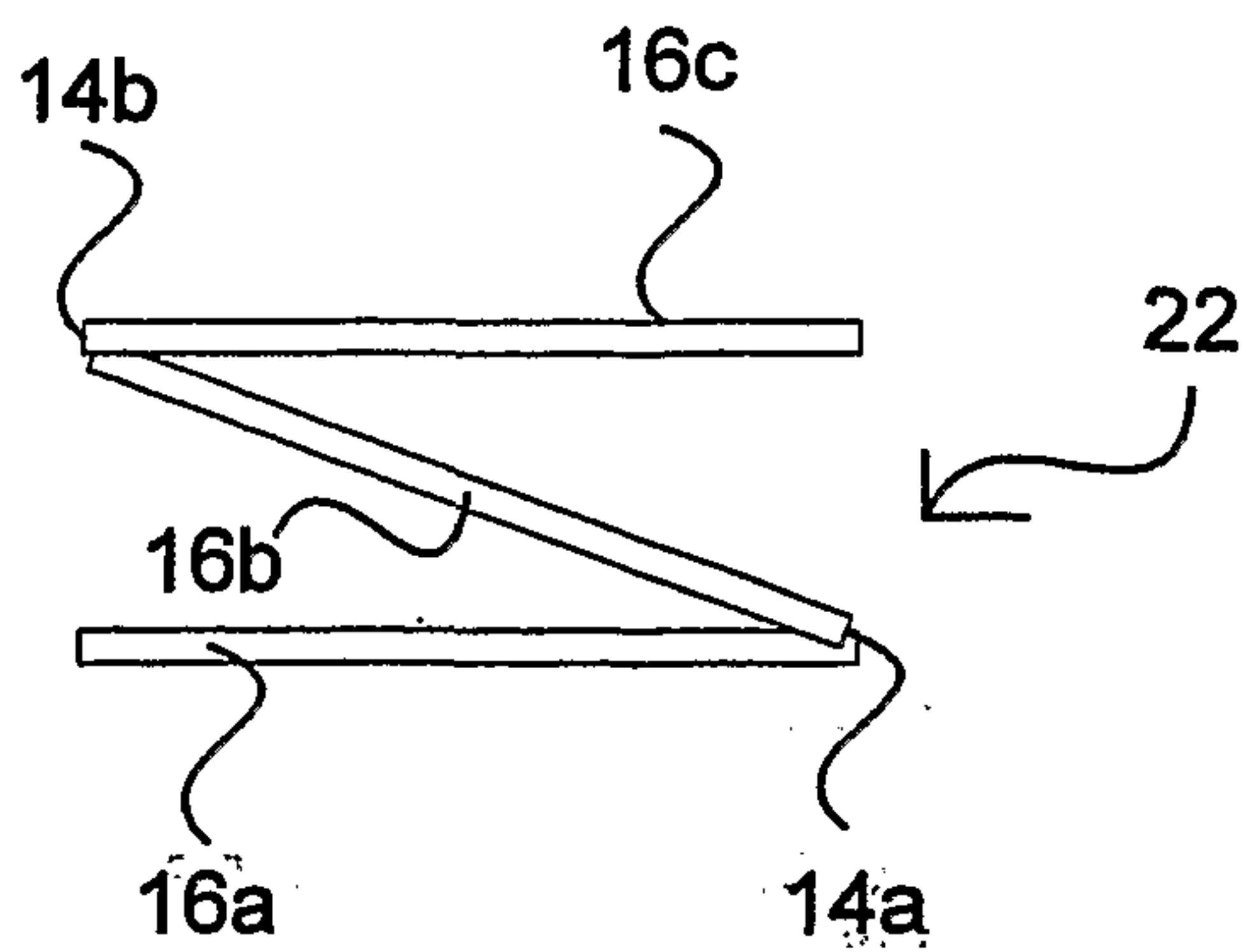

FIG. 3

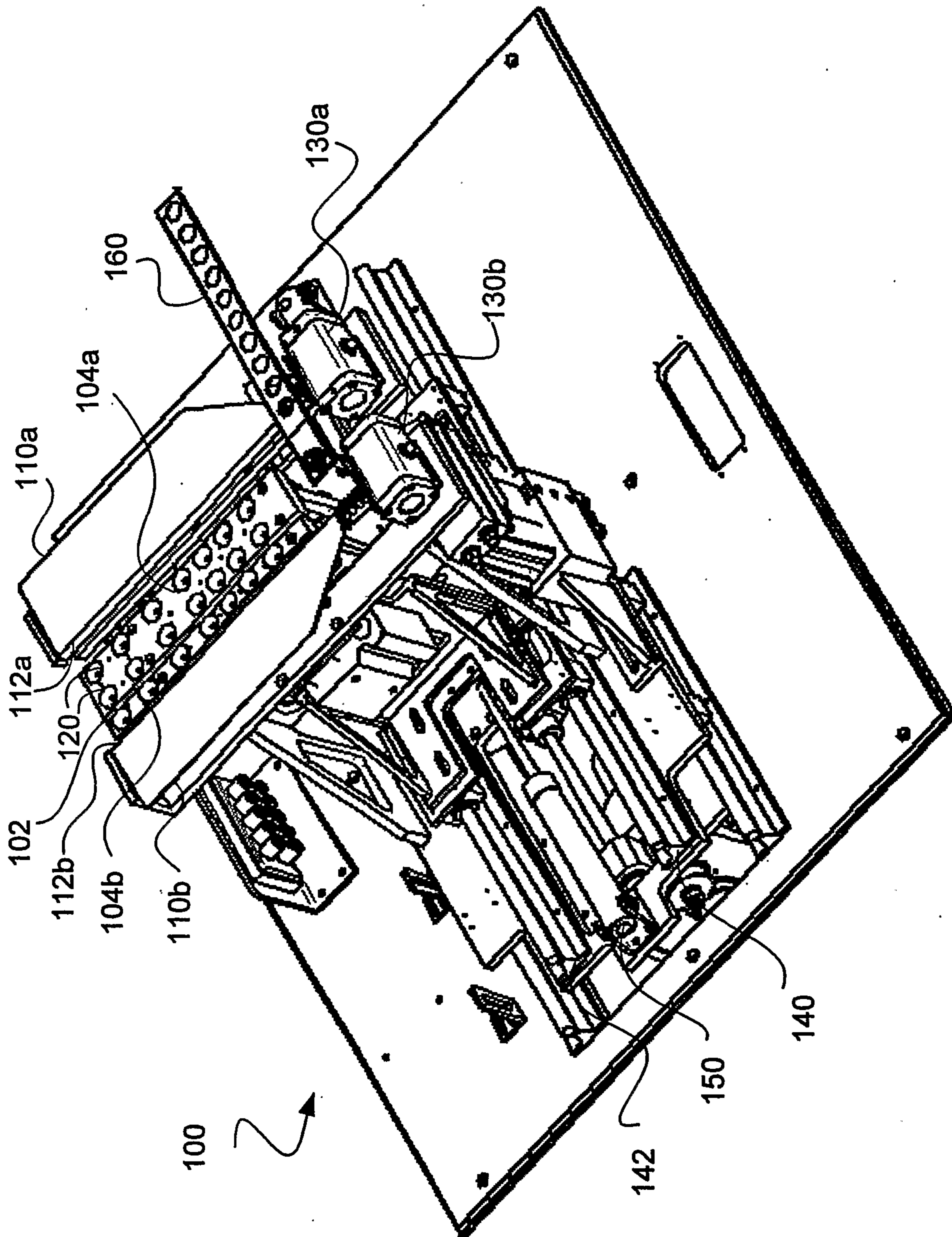

FIG. 4

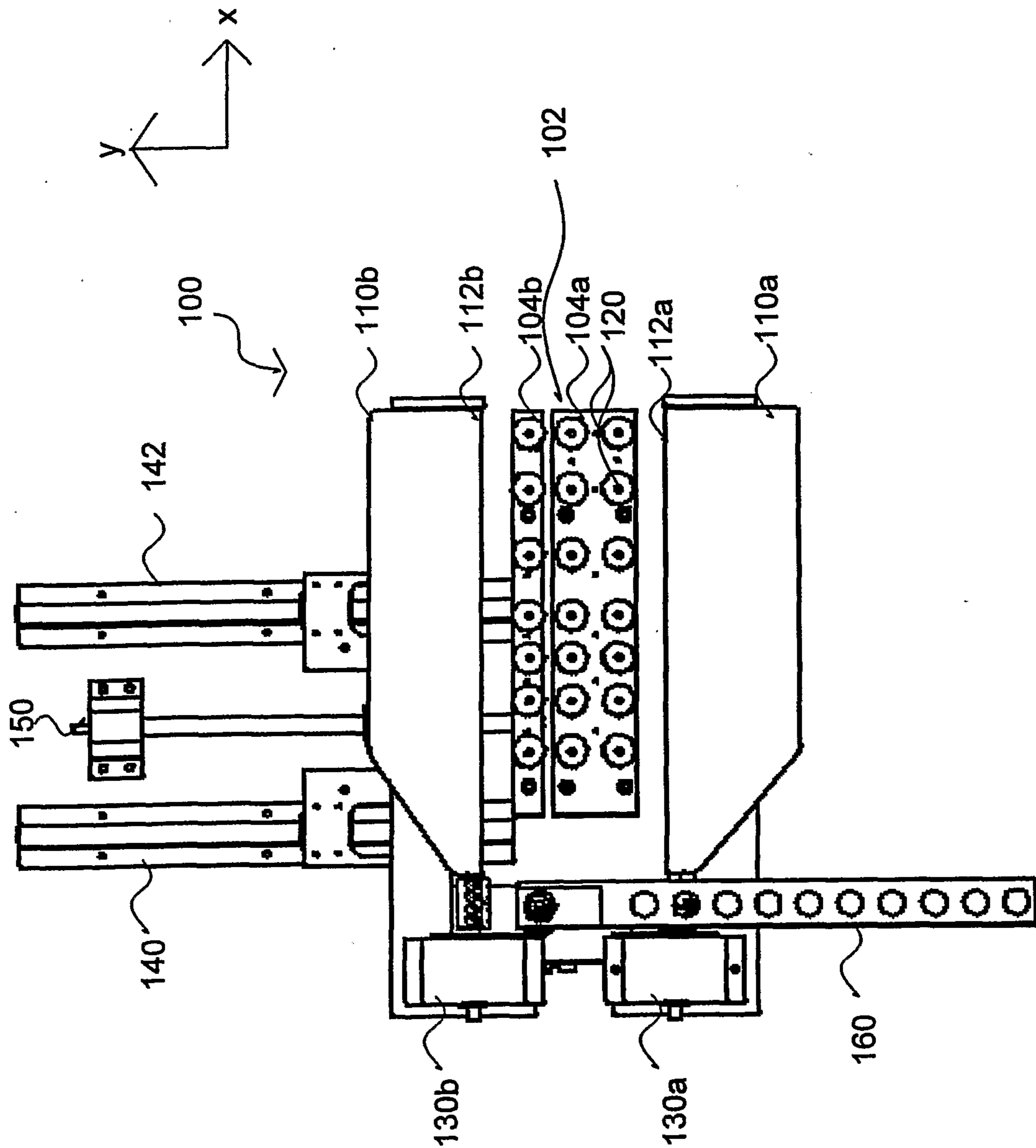

FIG. 5

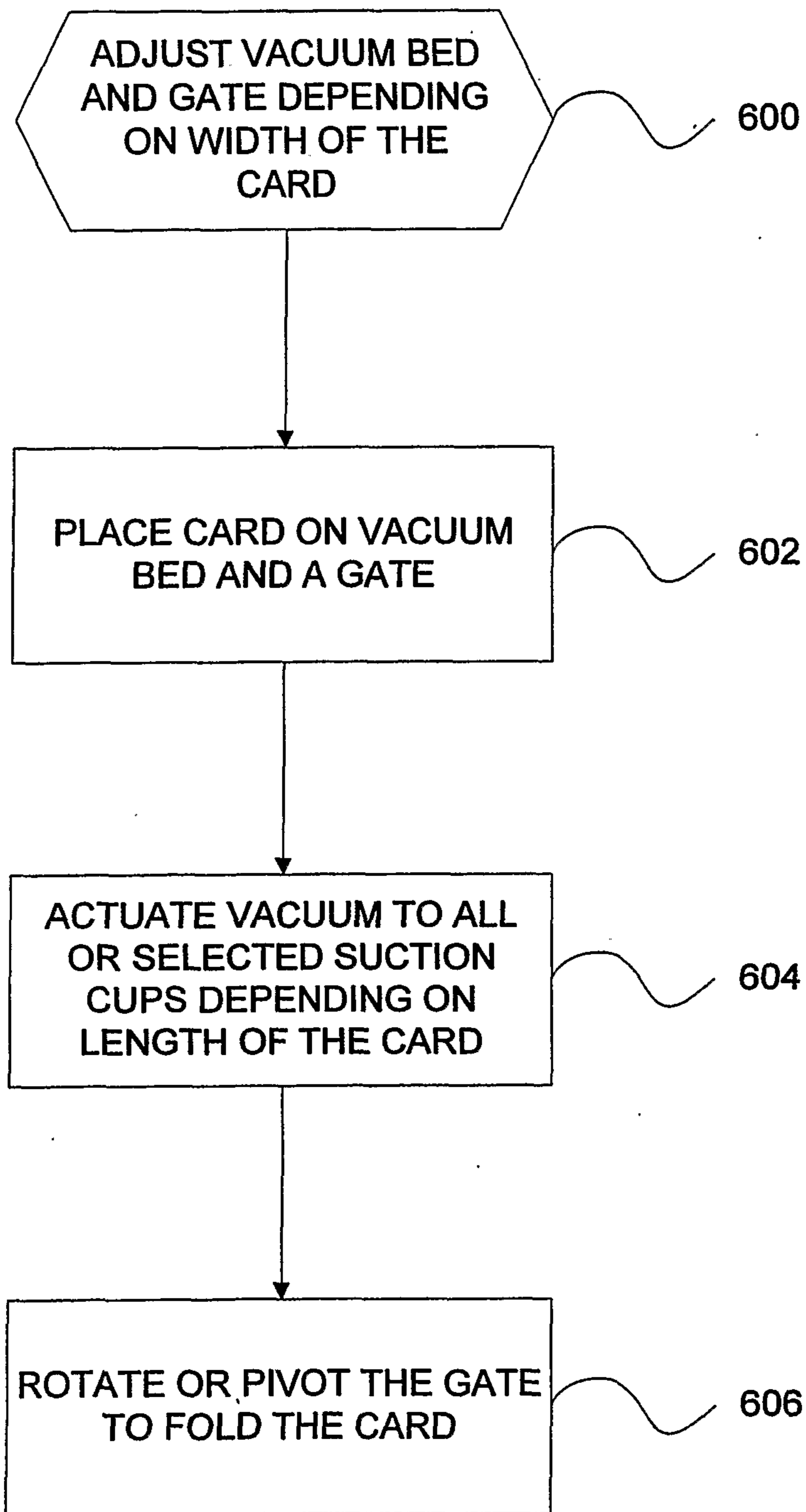

FIG. 6

5/6

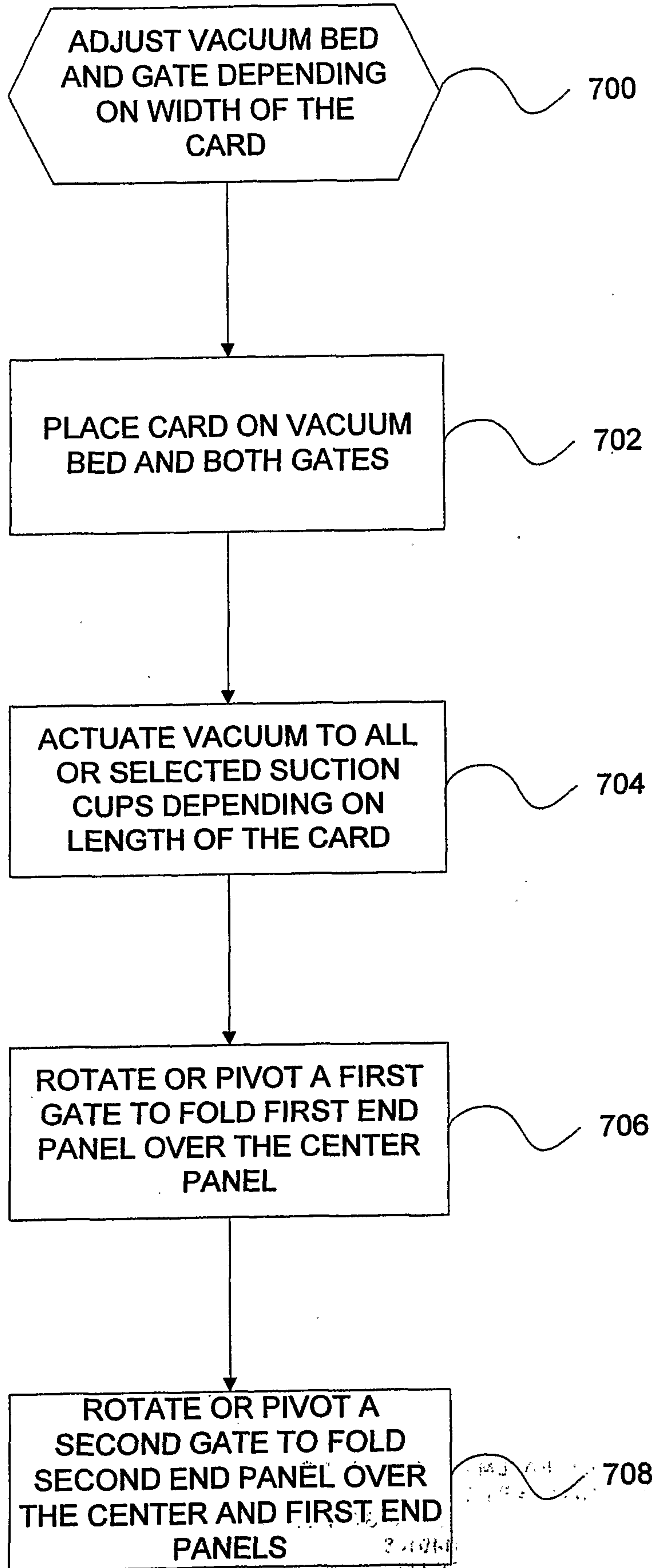

FIG. 7

6/6

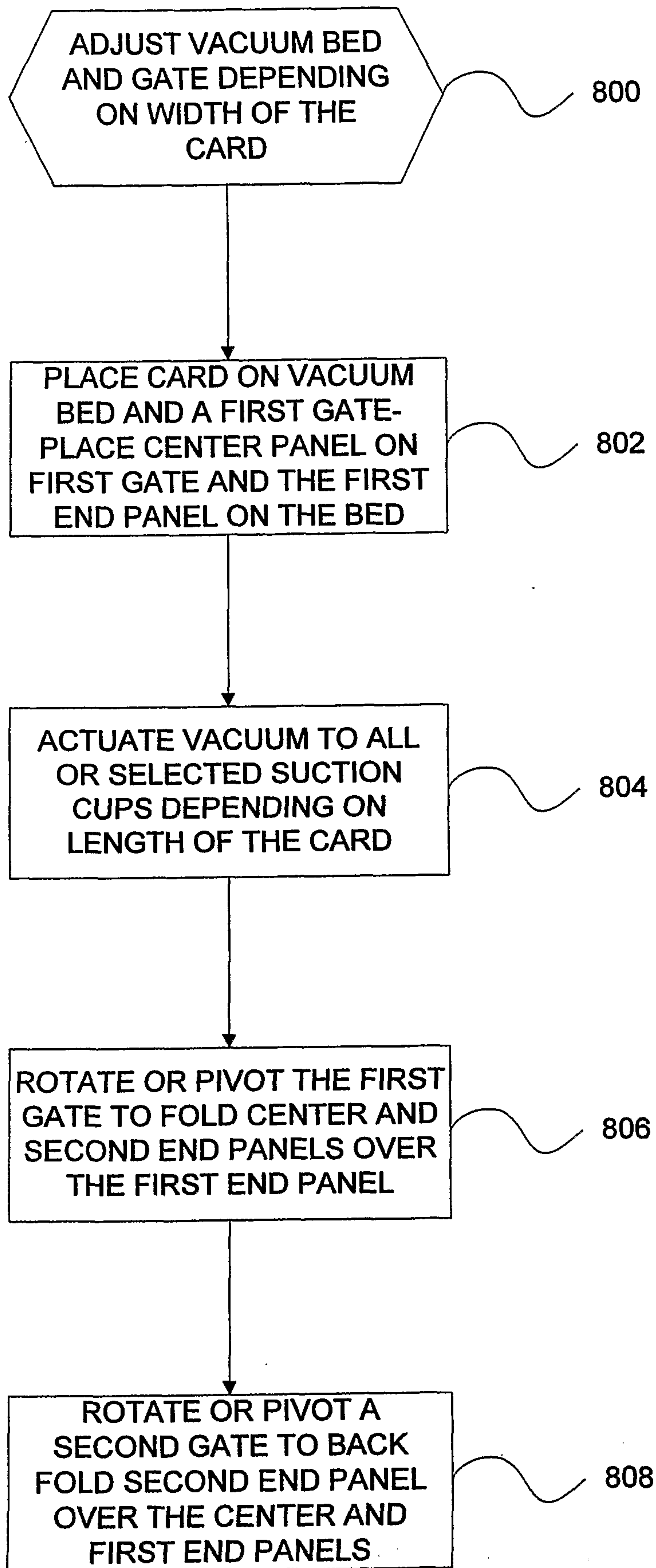

FIG. 8

