



US010112007B2

(12) **United States Patent**  
**Reid**

(10) **Patent No.:** **US 10,112,007 B2**  
(45) **Date of Patent:** **Oct. 30, 2018**

(54) **NEEDLE DEVICE HAVING SLIDEABLE MEMBER PROVIDING ENHANCED SAFETY**

(71) Applicant: **Alan Reid**, Keene, NH (US)

(72) Inventor: **Alan Reid**, Keene, NH (US)

(\* ) Notice: Subject to any disclaimer, the term of this patent is extended or adjusted under 35 U.S.C. 154(b) by 69 days.

(21) Appl. No.: **15/285,959**

(22) Filed: **Oct. 5, 2016**

(65) **Prior Publication Data**

US 2017/0021097 A1 Jan. 26, 2017

**Related U.S. Application Data**

(63) Continuation of application No. 12/264,509, filed on Nov. 4, 2008, which is a continuation of application No. 10/712,600, filed on Nov. 13, 2003, now Pat. No. 7,497,845, which is a continuation-in-part of application No. 10/242,976, filed on Sep. 13, 2002, now Pat. No. 6,755,805.

(51) **Int. Cl.**

**A61M 5/178** (2006.01)  
**A61M 5/162** (2006.01)  
**A61M 5/158** (2006.01)  
**A61M 25/06** (2006.01)  
**A61M 5/32** (2006.01)

(52) **U.S. Cl.**

CPC ..... **A61M 5/1626** (2013.01); **A61M 5/158** (2013.01); **A61M 25/0612** (2013.01); **A61M 5/3243** (2013.01); **A61M 5/3275** (2013.01); **A61M 2005/1581** (2013.01); **A61M 2005/1583** (2013.01)

(58) **Field of Classification Search**

CPC ..... A61M 5/3275; A61M 2005/1581; A61M 5/158; A61M 25/0612; A61M 5/3216; A61M 25/0637; A61M 25/0631; A61M 2005/1585

See application file for complete search history.

(56) **References Cited**

U.S. PATENT DOCUMENTS

4,735,618 A 4/1988 Hagen  
4,888,001 A \* 12/1989 Schoenberg ..... A61M 25/0637 604/162

4,944,731 A 7/1990 Cole  
5,135,507 A 8/1992 Haber et al.  
5,147,319 A 9/1992 Ishikawa et al.  
5,192,275 A 3/1993 Burns

(Continued)

OTHER PUBLICATIONS

Millennium Medical (Huber Plus, Safety Infusion Set), MMHP 01/00 Rev B, Apr. 25, 2001, 1 page.

(Continued)

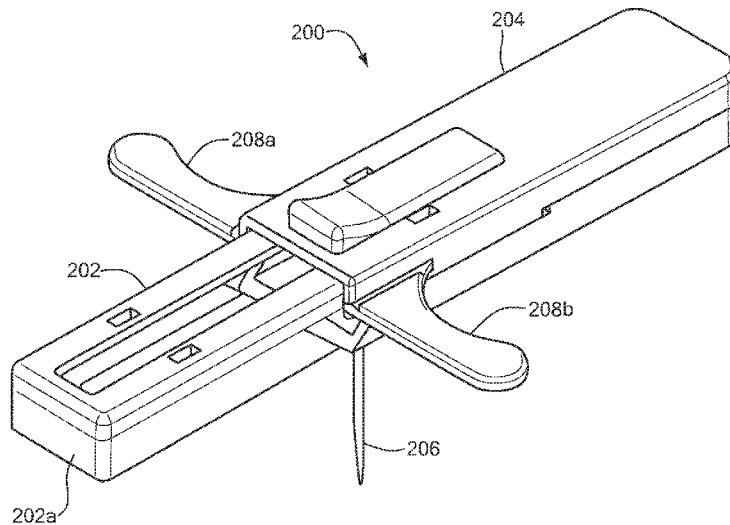
*Primary Examiner* — Emily Schmidt

(74) *Attorney, Agent, or Firm* — Daly, Crowley, Mofford & Durkee

(57) **ABSTRACT**

A medical device, such as a Huber-type device, includes a structure that enhances operator safety by reducing the likelihood that a needle will accidentally injure an operator. In one embodiment, the device includes a collapsible structure that can move from a use position to a non-use position. The device includes first and second wing portions and a channel for covering the needle as it is extracted from the patient. The structure enables the operator to leverage applied pressure for a smooth removal of the needle into the device for safe disposal.

**26 Claims, 11 Drawing Sheets**



(56)

References Cited

U.S. PATENT DOCUMENTS

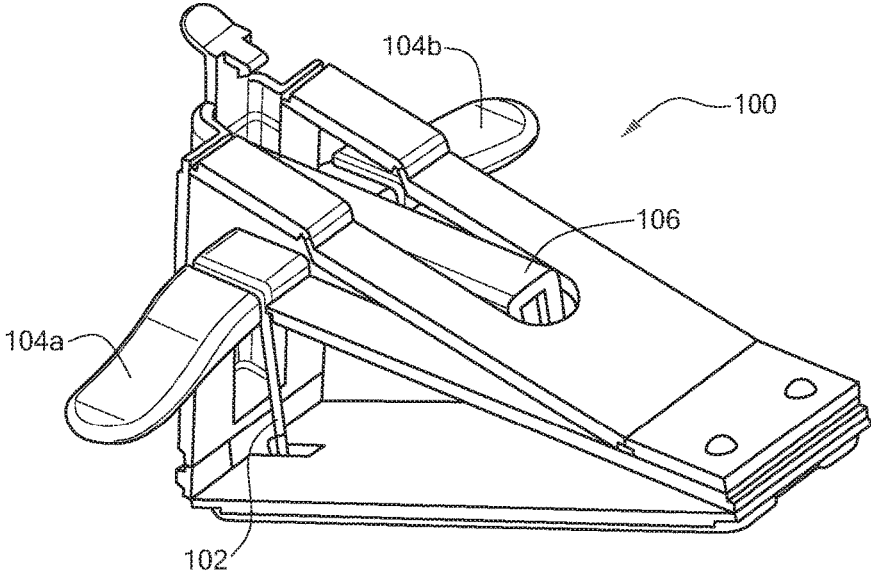
5,306,253	A *	4/1994	Brimhall .....	A61M 25/0637 604/165.03
5,338,306	A	8/1994	Srivatsa	
5,445,619	A	8/1995	Burns	
5,536,253	A	7/1996	Haber et al.	
5,607,398	A	3/1997	Parmigiani	
5,713,872	A	2/1998	Feuerborn et al.	
5,879,330	A	3/1999	Bell	
5,951,522	A *	9/1999	Rosato .....	A61M 25/0637 604/162
5,997,504	A	12/1999	Bell	
6,156,012	A	12/2000	Nathan	
6,210,371	B1	4/2001	Shaw	
6,500,155	B2	12/2002	Sasso	
6,663,604	B1 *	12/2003	Huet .....	A61M 5/3275 604/263
6,755,805	B1	6/2004	Reid	
6,830,562	B2	12/2004	Mogensen et al.	
7,097,637	B2	8/2006	Triplett et al.	
7,211,069	B2	5/2007	Lehmann	
7,497,845	B2	3/2009	Reid	
2002/0111581	A1	8/2002	Sasso	
2009/0054848	A1	2/2009	Reid	

OTHER PUBLICATIONS

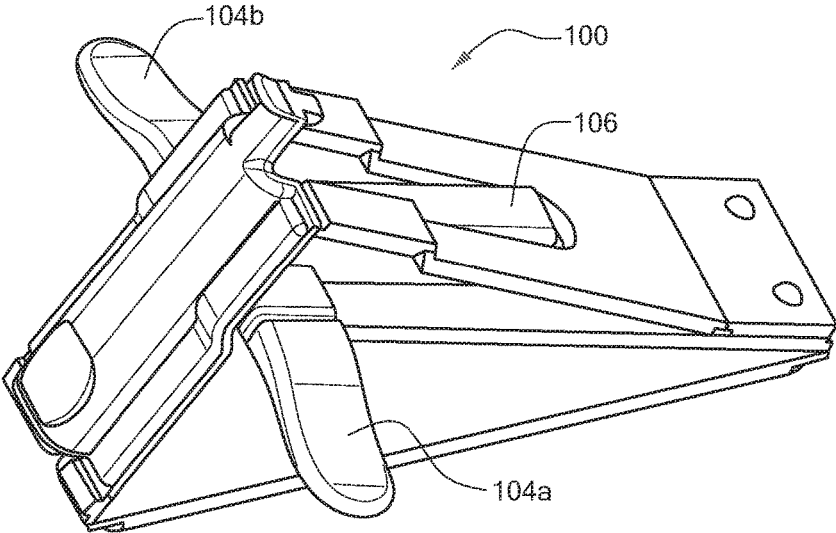
Office Action dated May 19, 2006 for U.S. Appl. No. 10/712,600; 12 pages.  
 Response to Office Action filed Sep. 28, 2006 for U.S. Appl. No. 10/712,600; 10 pages.  
 Office Action dated Oct. 6, 2006 for U.S. Appl. No. 10/712,600; 6 pages.  
 Response to Office Action filed Dec. 19, 2006 for U.S. Appl. No. 10/712,600; 14 pages.  
 Final Office Action dated Feb. 9, 2007 for U.S. Appl. No. 10/712,600; 7 pages.  
 Interview Summary dated Mar. 8, 2007 for U.S. Appl. No. 10/712,600; 3 pages.  
 Response to Final Office Action filed Aug. 9, 2007 for U.S. Appl. No. 10/712,600; 32 pages.

Response to Office Action filed Sep. 5, 2007 for U.S. Appl. No. 10/712,600; 8 pages.  
 Office Action dated Oct. 29, 2007 for U.S. Appl. No. 10/712,600; 7 pages.  
 Response to Office Action filed Apr. 23, 2008 for U.S. Appl. No. 10/712,600; 11 pages.  
 Final Office Action dated May 27, 2008 for U.S. Appl. No. 10/712,600; 8 pages.  
 Response to Final Office Action filed Oct. 2, 2008 for U.S. Appl. No. 10/712,600; 5 pages.  
 Notice of Allowance dated Oct. 29, 2008 for U.S. Appl. No. 10/712,600; 4 pages.  
 Office Action dated Apr. 20, 2009 for U.S. Appl. No. 12/264,509; 8 pages.  
 Response to Office Action filed Sep. 17, 2009 for U.S. Appl. No. 12/264,509; 8 pages.  
 Final Office Action dated Nov. 6, 2009 for U.S. Appl. No. 12/264,509; 7 pages.  
 Notice of Appeal filed May 3, 2010 for U.S. Appl. No. 12/264,509; 1 page.  
 Office Action dated Jun. 26, 2013 for U.S. Appl. No. 12/264,509; 7 pages.  
 Response to Office Action filed Nov. 25, 2013 for U.S. Appl. No. 12/264,509; 11 pages.  
 Final Office Action dated Dec. 16, 2013 for U.S. Appl. No. 12/264,509; 9 pages.  
 Notice of Appeal filed Mar. 6, 2014 for U.S. Appl. No. 12/264,509; 1 page.  
 Appeal Brief filed Jul. 7, 2014 for U.S. Appl. No. 12/264,509; 20 pages.  
 Examiner's Answer to Appeal Brief dated Jul. 28, 2014 for U.S. Appl. No. 12/264,509; 5 pages.  
 Reply Brief Filed Aug. 18, 2014 for U.S. Appl. No. 12/264,509; 9 pages.  
 Decision on Appeal dated Aug. 5, 2016 for U.S. Appl. No. 12/264,509; 14 pages.  
 U.S. Appl. No. 10/242,976.  
 U.S. Appl. No. 10/712,600.  
 U.S. Appl. No. 12/264,509.

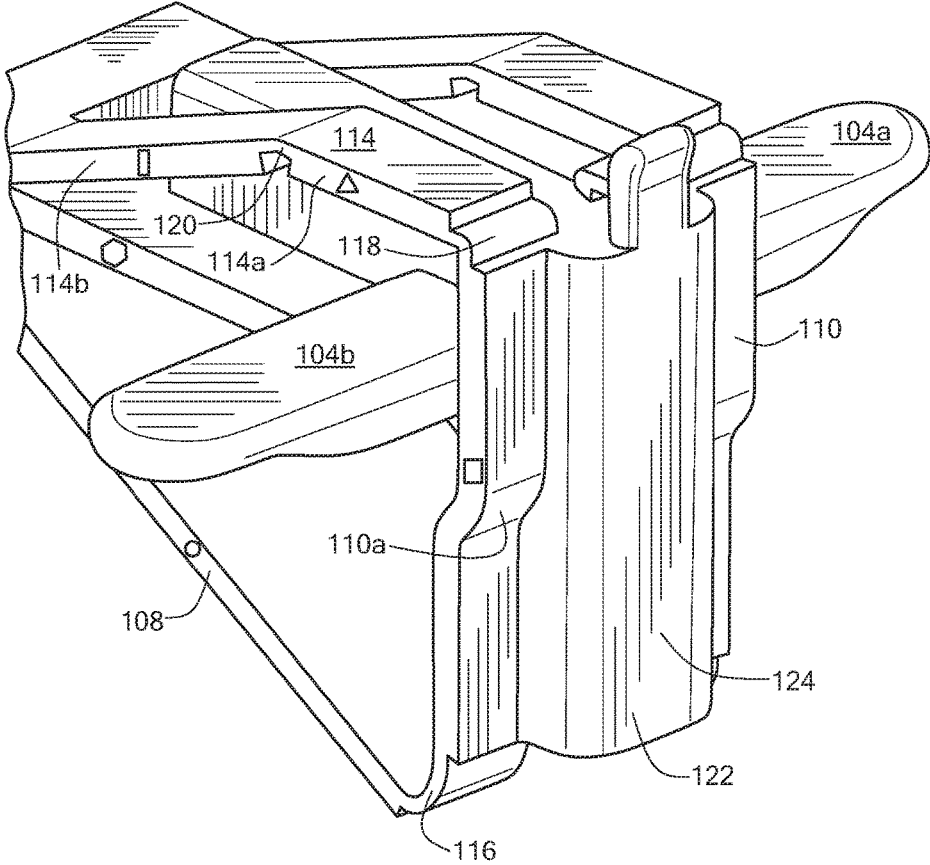
\* cited by examiner



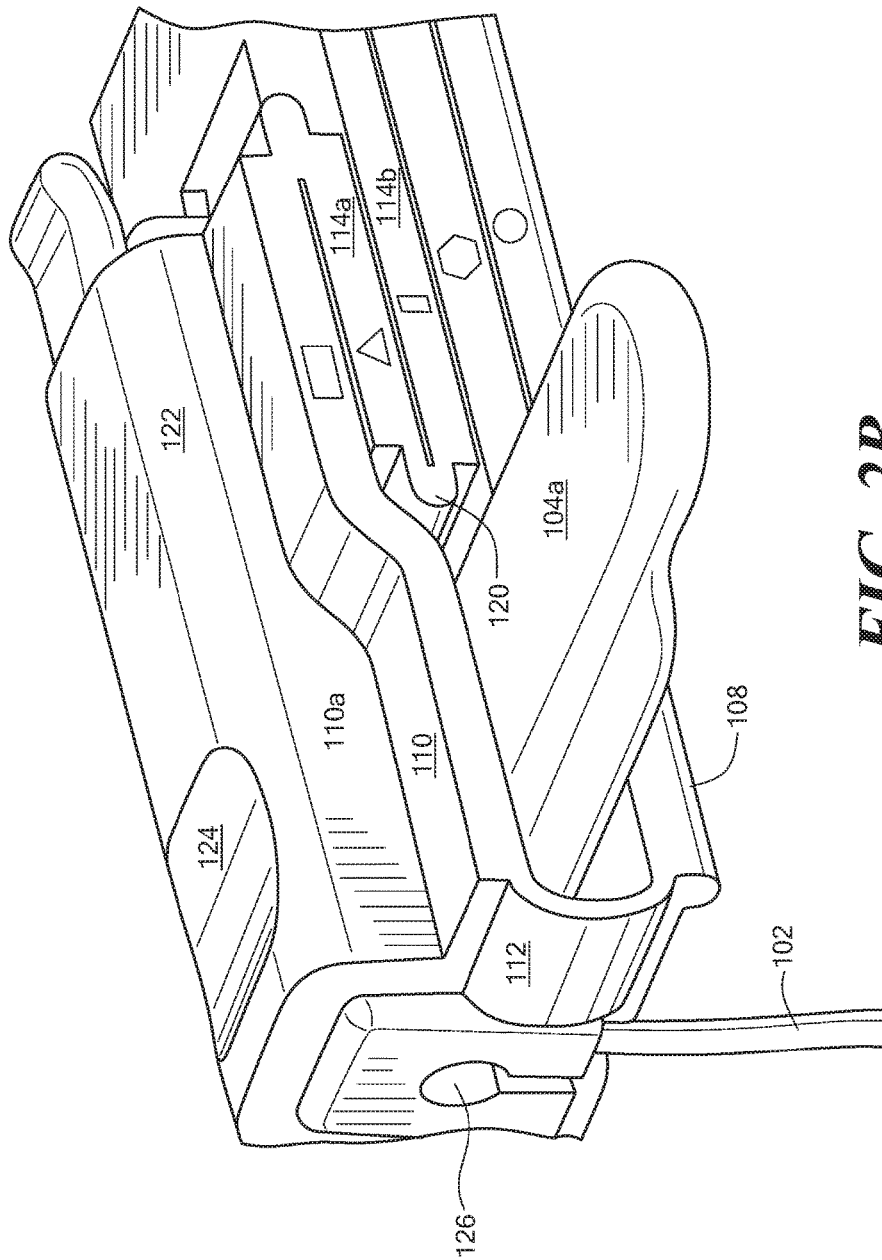
**FIG. 1A**



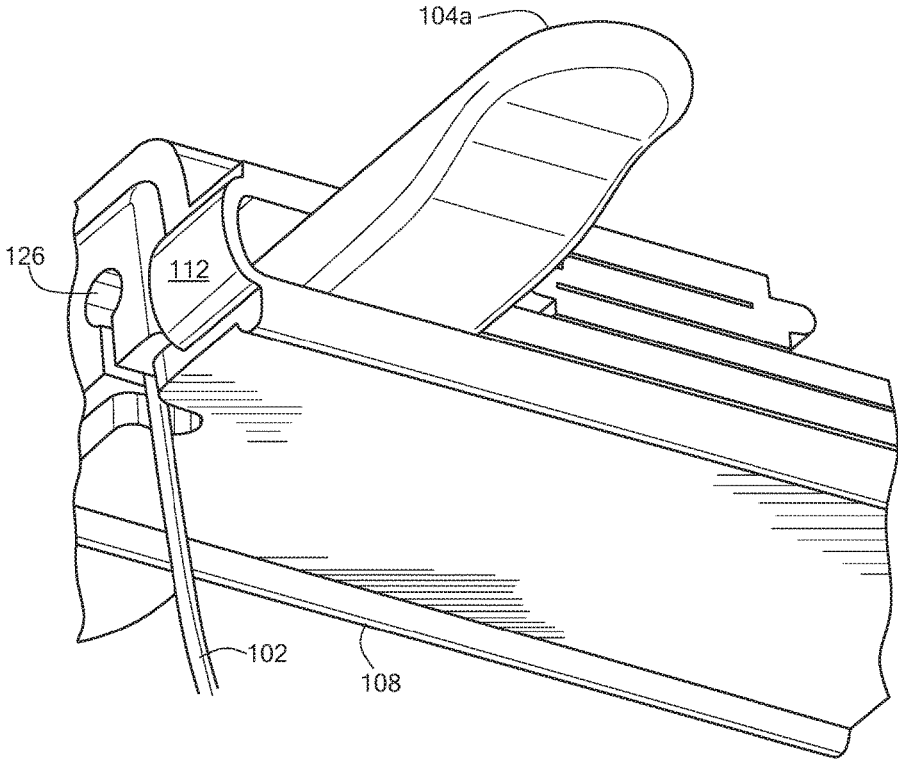
**FIG. 1B**



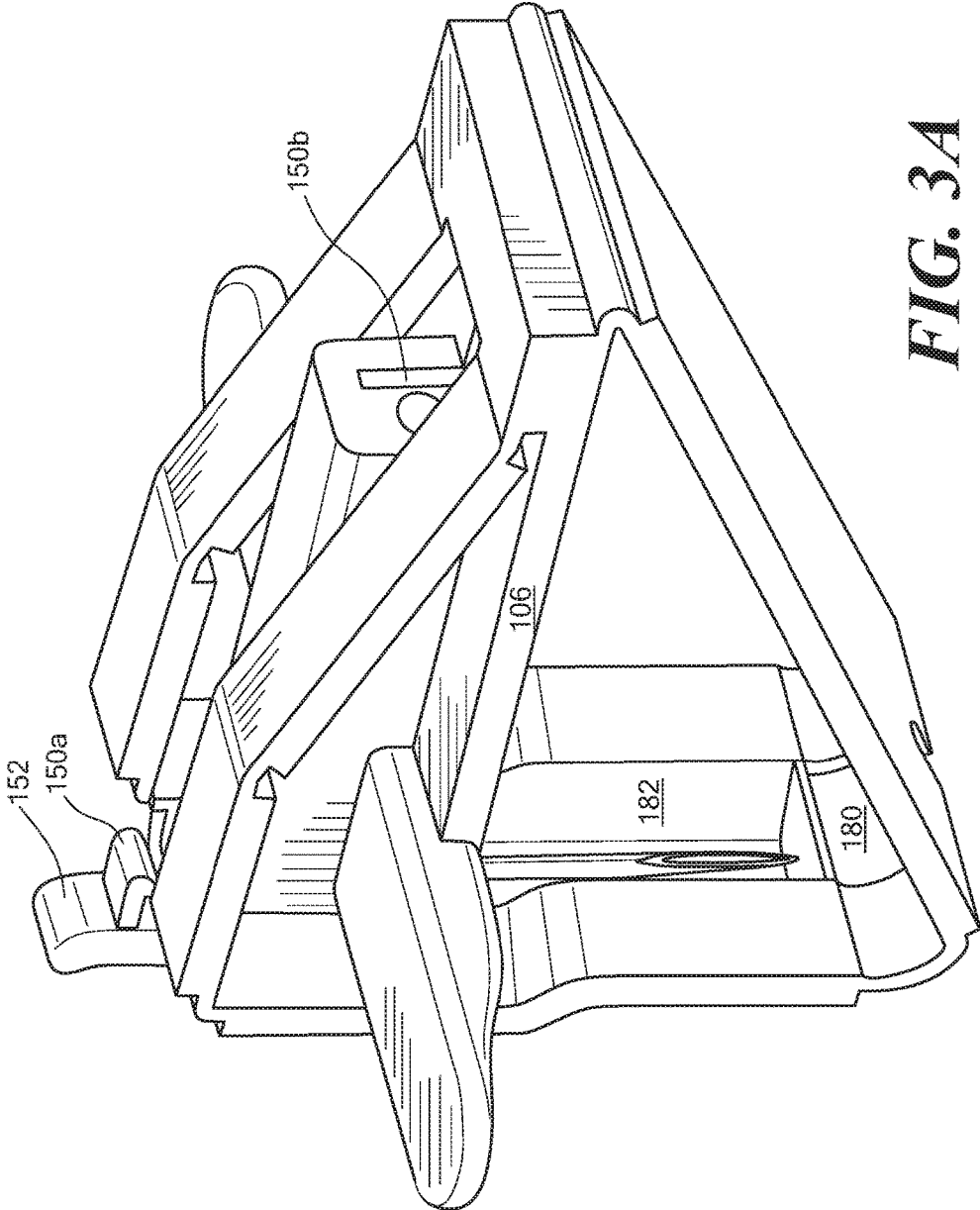
**FIG. 2A**



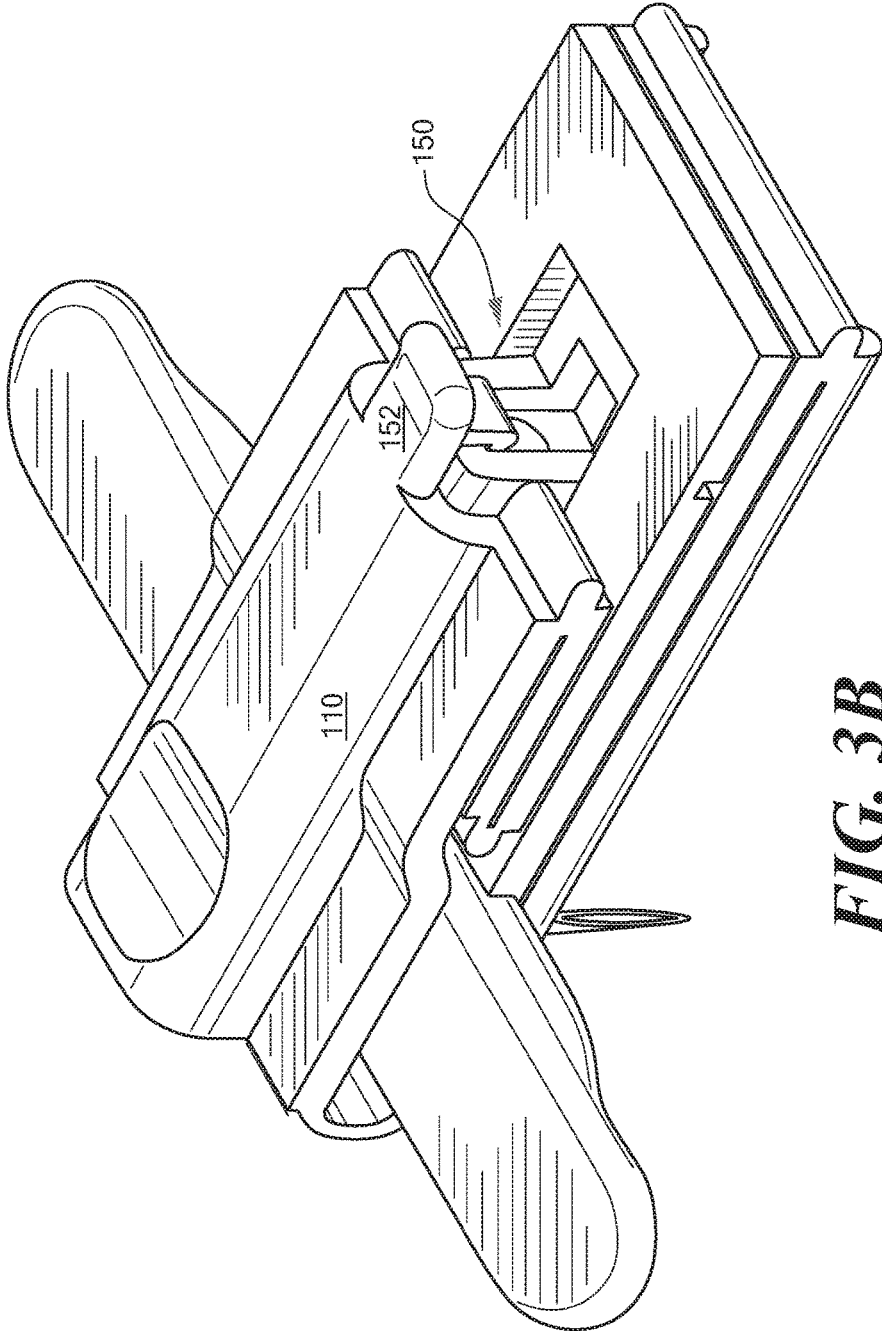
**FIG. 2B**



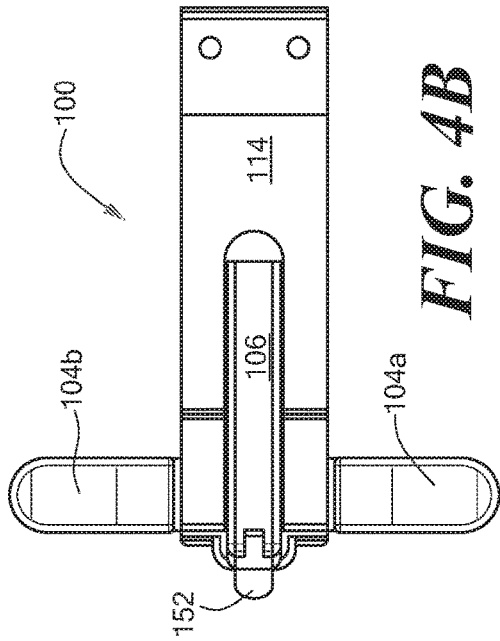
**FIG. 2C**



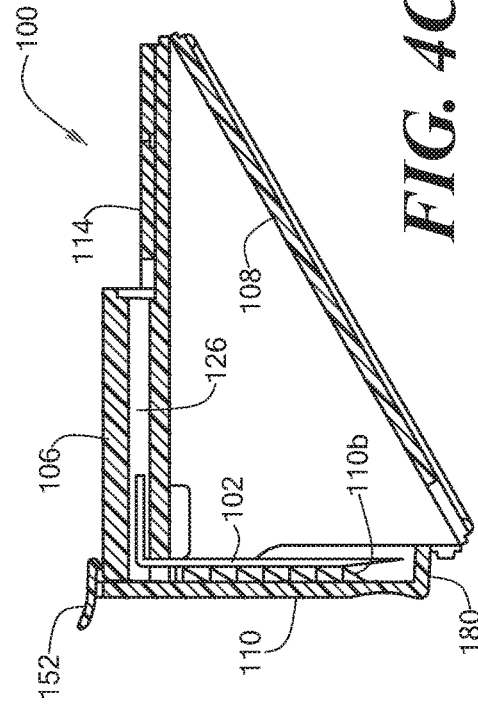
**FIG. 3A**



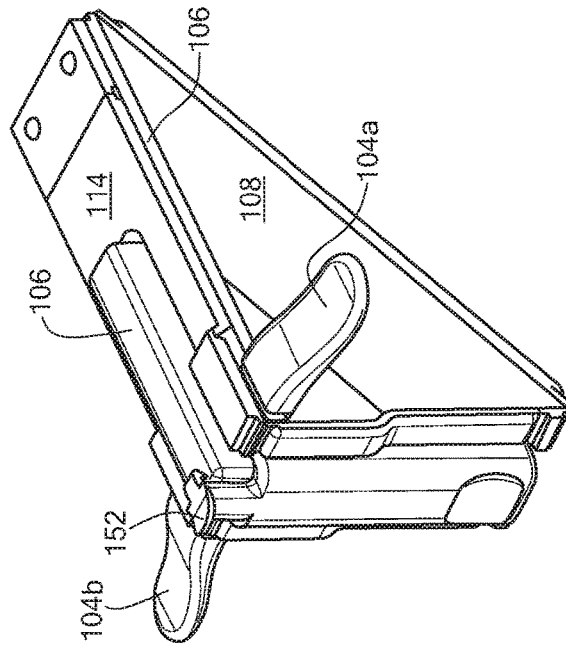
**FIG. 3B**



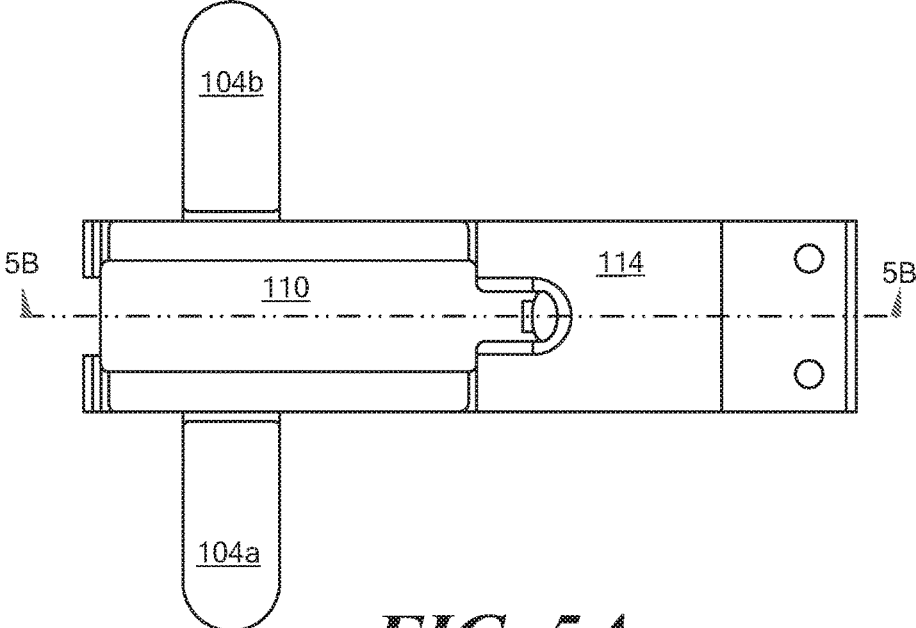
**FIG. 4B**



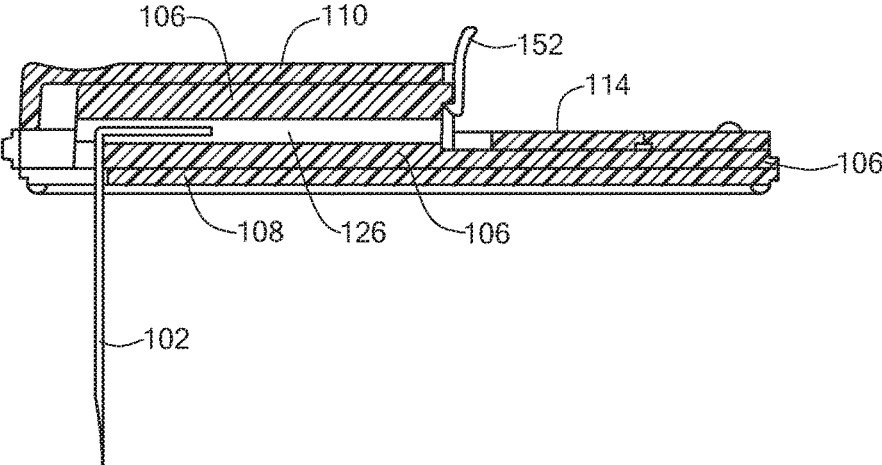
**FIG. 4C**



**FIG. 4A**

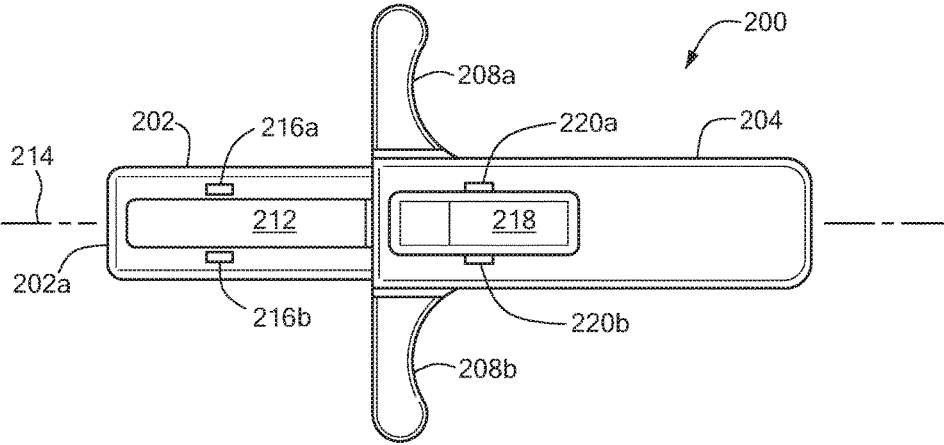
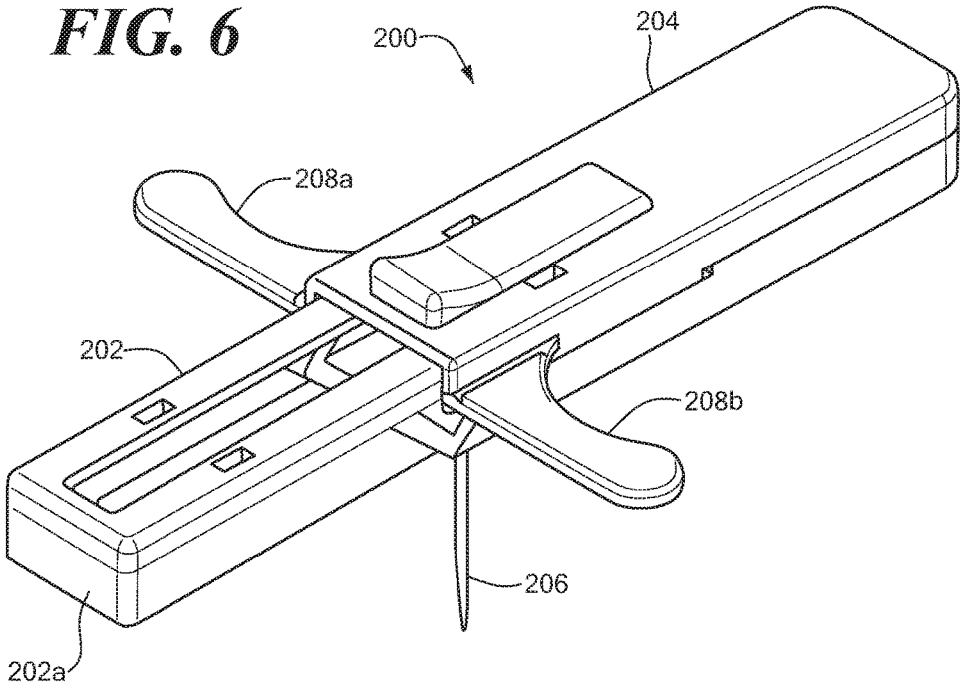


**FIG. 5A**

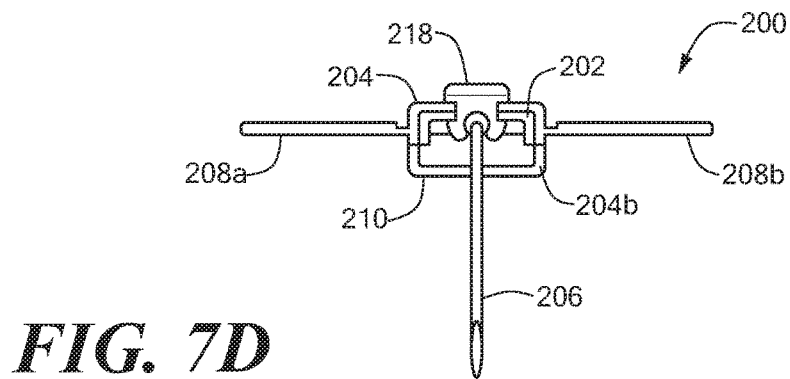
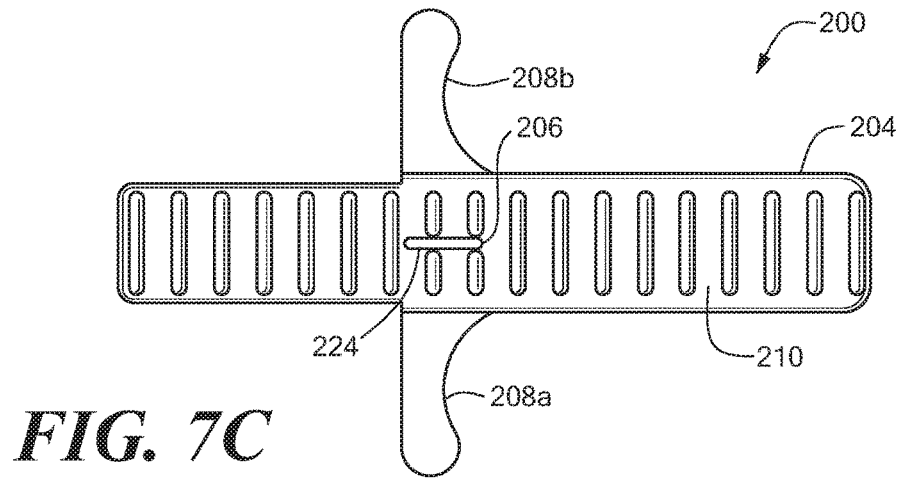
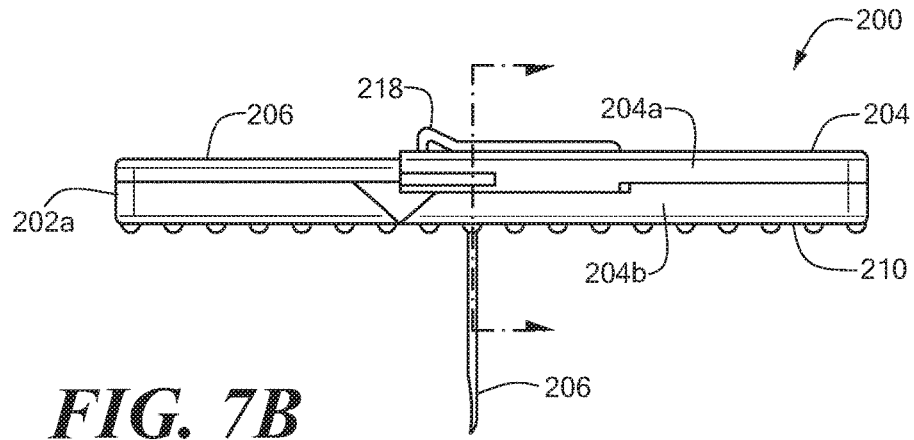


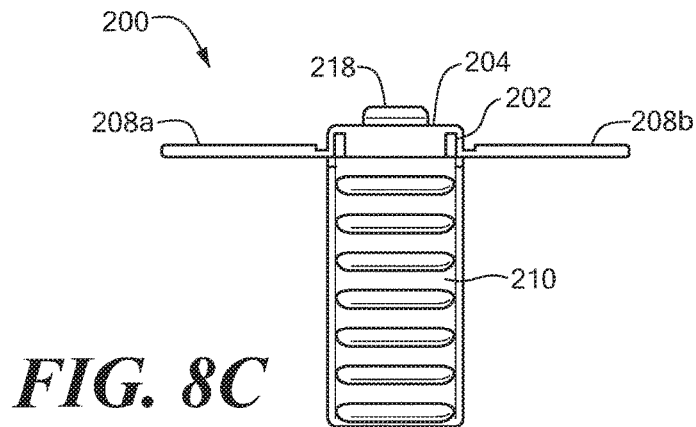
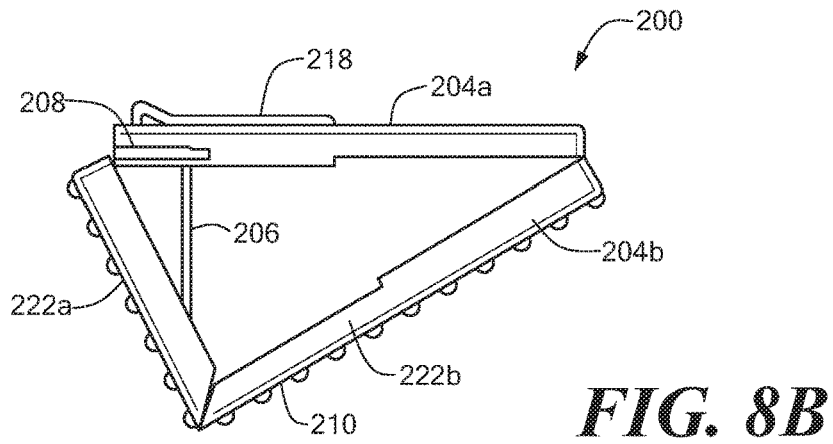
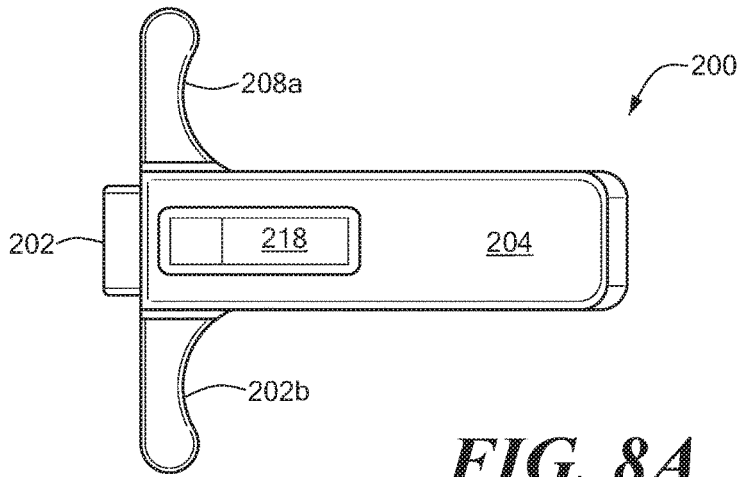
**FIG. 5B**

**FIG. 6**



**FIG. 7A**





## NEEDLE DEVICE HAVING SLIDEABLE MEMBER PROVIDING ENHANCED SAFETY

### CROSS REFERENCE TO RELATED APPLICATIONS

This application is a Continuation of U.S. patent application Ser. No. 12/264,509, filed Nov. 4, 2008, which application is a Continuation of U.S. patent application Ser. No. 10/712,600, filed Nov. 13, 2003, which application is a Continuation-in-Part of U.S. patent application Ser. No. 10/242,976, filed Sep. 13, 2002, which applications are incorporated by reference herein in their entirety.

### BACKGROUND OF THE INVENTION

Medical devices for injecting fluids into a patient are well known in the art. One such type of device is generally referred to as implanted ports, which can be implanted subcutaneously in a patient. Various types of ports can be used to provide access to the peritoneal cavity, as well as the vascular, arterial, and epidural systems. The ports typically include a catheter for access to a large vein and a port body having a septum, which is generally formed from silicone.

The port is implanted within a cavity formed in the patient, such as in the chest area, and sutured to underlying tissue. From time to time, it is desirable to refill the port via the septum and/or provide an external source of fluid, e.g., IV access. One type of device used to refill an implanted port is generally known as a Huber needle. Known Huber needles generally include a needle extending from a base structure. With sufficient expertise and experience an operator, such as a nurse, can insert the needle into the port via the septum, which is sliced (not cored) by the needle for self-sealing. The Huber needle can then be taped to the patient and fluid delivered to the patient intravenously as desired via a coupled to the Huber needle device.

However, conventional Huber device can be relatively difficult to remove from the patient. An operator may need to apply a significant amount of force to initiate removal of the device. If the needle suddenly releases, the operator may be accidentally injured by the needle as it is uncontrollably freed from the patient. In addition, even after safe removal, known Huber needle devices can present a hazard due to the outwardly extending needle.

It would, therefore, be desirable to overcome the aforesaid and other disadvantages.

### SUMMARY OF THE INVENTION

The present invention provides a medical device, such as a Huber needle, having a needle and a structure that enhances user safety during removal of the needle from a patient. The inventive structure reduces the likelihood that medical personnel will suffer injury from the needle as it is forcibly removed from the patient. While the invention is primarily shown and described in conjunction with a Huber-type needle, it is understood that the invention is applicable to devices in general in which it is desirable to reduce the possibility of injury from a needle.

In one aspect of the invention, a medical device includes a central structural member from which a needle extends. At least one wing portion extends from the central structural member for facilitating removal of the needle from the patient in a controlled manner. A base member for contacting the patient's skin is coupled to the central structural member. First and second members are pivotably secured to the base

member so as to provide a structure that can be transitioned from a use position in which the needle extends from the device for insertion into the patient and a non-use position in which the needle is captured by the first member as the needle is extracted from the patient.

With this arrangement, an operator leverages pressure applied to the wing portion(s) with a finger(s) and counter pressure on the first member so as to enable a controlled removal of the needle from the patient. In addition, the collapsible/expandable structure captures the needle in the first member as it is removed from the patient to enhance operator safety.

In another aspect of the invention, a medical device has a use position and a non-use position with a housing having first and second portions each having respective first and second ends. The second portion has a first position in the use position and a second position in the non-use position. A longitudinal member has first and second ends and extends from the housing in the use position. In the non-use position, the longitudinal member is captured by the first housing portion. A needle extends from the device in the use position and envelops the device the non-use position. The device can include one or more locking mechanisms to secure the device in the non-use position.

### BRIEF DESCRIPTION OF THE DRAWINGS

The invention will be more fully understood from the following detailed description taken in conjunction with the accompanying drawings, in which:

FIGS. 1A and 1B are perspective schematic depictions of a medical device having enhanced safety in accordance with the present invention in the non-use position;

FIG. 2A is a perspective schematic depiction of the medical device of FIG. 1 in the non-use position;

FIG. 2B is a perspective schematic depiction of the medical device of FIG. 2A in a use position;

FIG. 2C is a bottom perspective view of the device of FIG. 2B;

FIG. 3A is a perspective schematic depiction of a medical device having enhanced safety in accordance with the present invention in a non-use position;

FIG. 3B is a perspective schematic depiction of the medical device of FIG. 3A in the use position;

FIG. 4A is a perspective schematic depiction of an exemplary medical device having enhanced safety in accordance with the present invention shown in a non-use position;

FIG. 4B is a top view of the device of FIG. 4A;

FIG. 4C is a sectional view of the device of FIG. 4B;

FIG. 5A is a top view of the exemplary medical device of FIG. 4A shown in a use position; and

FIG. 5B is a sectional view of the device of FIG. 5A along line 5B.

FIG. 6 is a perspective schematic representation of an exemplary medical device shown in a use position in accordance with the present invention;

FIG. 7A is a top view of the medical device of FIG. 6;

FIG. 7B is a side view of the medical device of FIG. 6;

FIG. 7C is a bottom view of the medical device of FIG. 6;

FIG. 7D is a cross-sectional view along line 7D of the medical device of FIG. 7B;

FIG. 8A is a top view of the medical device of FIG. 6 in a non-use position;

FIG. 8B is a side view of the medical device of FIG. 6 in a non-use position; and

FIG. 8C is a front view of the medical device of FIG. 6 is a non-use position.

#### DETAILED DESCRIPTION OF THE INVENTION

FIGS. 1A-1B show a medical device 100 including a needle 102 and a structure for enhanced operator safety in accordance with the present invention. In general, the device structure facilitates removal of the needle from a patient and captures the needle as it is retracted from the patient's body. During use, the device is relatively flat or collapsed and the needle extends outwardly for insertion into an implanted port device, for example. After use, the device is transitioned to the non-use position in which the needle is captured within the device. As described below, the device can include various features to prevent a transition to the use position from the non-use position to preclude re-use of the device.

The device 100 includes opposed first and second wing portions 104a,b extending from a central structural member 106. As described below, the wing portions 104 provide surfaces on which an operator can apply pressure to insert the device. This arrangement leverages the force applied to the device so as to provide smooth, and safe, insertion and extraction of the needle from the patient.

FIGS. 2A-2C show further details of an exemplary medical device 100' having a structure providing enhanced safety features in accordance with the present invention. In general, the device of FIGS. 1A and 1B is similar to the device of FIGS. 2A-2C in which like reference designations indicate like elements. The device 100 includes a series of interconnected members that move with respect to the central structural member 106 for safely transitioning the device from use position to the non-use position. The various members shown in FIGS. 2A and 2B are marked with a particular shape as shown to designate the corresponding parts on each of these figures.

A first member 110 is pivotably coupled to a skin-contacting base member 108 at a pivot 112. In an exemplary embodiment, the first member 110 includes an arcuate portion 110a for accommodating the stacked members in the use position, as best shown in FIG. 2B. A second member 114, at respective pivots 116, 118, extends between the base member 108 and the first member 110. In one embodiment, the second member 114 includes first and second sub portions 114a,b joined at a pivot point 120 to enable the second member first and second sub portions 114a,b to fold under the first member 110. It is understood that these members have mirror images on each side of the central structural member 106.

The device further includes a raised portion 122 that can form a part of the first member 110. As shown in FIGS. 2A and 2B, the raised portion 122 can include a depression 124 that can be pressured by an operator's thumb, for example, to insert the device into the patient. As used herein, the use position refers to the needle outwardly extending from the device for insertion into a patient. In the use position, the device is "flat" or collapsed.

As shown in FIGS. 2B and 2C, (and 4C and 5B) for example, the central structural member 106 can include a slotted channel 126 from which the needle extends perpendicularly, for example. The needle 102 can have an L-shape to facilitate coupling of the needle with a tube (not shown) disposed within the channel 126. The needle can be secured within the channel 126 in a conventional manner, such as by adhesive.

The device can include various features to improve the operation and safety of the device. For example, the device can include one or more latches to further enhance operator safety.

As shown in FIGS. 3A-3B, the device can include a first latching mechanism 150 located at an end of the first member 110. In one particular embodiment, the first latching mechanism includes a tab 152 to facilitate detachment of a latch member 150a from a receiving aperture or cutout 150b in the central structural member 106. The latching mechanism 150 can be released to raise the first member 110 by lifting the tab 152 prior to removal of the device from the patient.

A second latch 180 shown in FIGS. 3A (and 4C) for example, can be located at a tip of the first member 110 so that the needle is retained within the first member. In an exemplary embodiment, the needle 102 is captured by an arcuate cavity 182 formed in the first member 110. Once the device transitions to the non-use position, the second latch 180 prevents the device from transitioning to the use position by retaining the needle within the cavity.

In another embodiment (not shown), the device can include mechanisms to provide unidirectional movement to the non-use position. In one embodiment, the first member includes a ratchet-type device allowing only movement of the first member 110 away from the base member 108.

Referring again to FIGS. 2A-3B, the structure of the device 100 leverages the force applied to the wing portions 104 and the first member 110 to ease extraction of the needle from the patient. In one embodiment, while the device is flush with the patient's skin, the operator moves the first member 110 to an upright position with respect to the central structural member 106. The operator then applies first and second fingers underneath the wing portions 104 and a thumb, for example, on or near the tab 152 of the first member 110. By applying force on top of the upright first member 110, the implanted port is stabilized in position. The operator can then apply force to lift the wing portions 104 up while applying a counter-force on the first member 110 to leverage the force applied on the wing portions.

The applied pressure forces the central structural member 106 and wings 104 up and away from the base member 108 and the needle 102 retracts into the cavity 182 in first member 110. With this arrangement, it is relatively easy for the operator to apply steady pressure to the device for a smooth extraction of the needle from the patient. That is, the needle is not suddenly freed from the patient in a relatively out of control manner. It is understood that the tab 152 can be shaped to facilitate movement of the first member 110 to an upright position and to accommodate force applied to the tab 152 by the operator's thumb.

FIGS. 4A-5B show further details of a Huber needle-type device, such as the device 100 of FIGS. 1A and 1B, having enhanced safety features in accordance with the present invention. FIGS. 4A-4C show a device in the non-use position from a perspective, top, and sectional view, respectively. FIG. 5A is a top view of a device in the use position in accordance with the present invention and FIG. 5B is a sectional view taken along line 5B of FIG. 5A.

In one embodiment, the devices can be delivered in the use position. As described above, the devices can include various features to prevent a transition from the use position to the non-use position.

In a further aspect of the invention shown in FIG. 6, a medical device 200, which is shown in a user position, includes a longitudinal member 202 that slides into a housing 204. In an exemplary embodiment, the device 200 locks

in a non-use position after removal of a needle **206** from a patient. In general, when the device **200** is in the use position, a user can apply finger pressure to first and second wing portions **208a,b** and thumb pressure to an end **202a** of the longitudinal member to force retraction of the needle **206** from the patient's body. When the longitudinal member **202** is captured by the housing **204**, the needle **206** no longer protrudes from the device **200** to enhance operator safety.

FIGS. 7A-8C show further details of the device **200** shown in FIG. 6. FIGS. 7A-7D show the device **200** in a first or use position and FIGS. 8A-8C show the device **200** in a second or non-use position. A user or operator transitions the device **200** from the use position to the non-use position as described in detail below.

As shown in FIGS. 7A-7D, in the use position the needle **206** protrudes from the device **200** for insertion into a patient. The device **200** is relatively flat in the use position so that a bottom surface **210** can rest on a patient while the needle **206** is disposed beneath the skin. The extended longitudinal member **202** includes a channel **212**, which can be centered about a longitudinal axis **214** of the device. The needle **206** extends through the channel, which allows axial movement of the longitudinal member. The longitudinal member **202** further includes a first and optional second locking mechanism **216a, 216b** for securing the longitudinal member **202** in the non-use position, as described more fully below.

In an exemplary embodiment, the housing **204** include first and second portions **204a, 204b** that are secured to each other. In one embodiment, one end of the second housing portion **204b** is coupled to one end of the longitudinal member **202** and the other end of the second housing portion is coupled to an end of the first housing portion **204a**. Optional first and second wing portions **208a, 208b** extend from the housing first portion **204a**. The wing portions **208** can be arcuate as shown to receive, for example, the application of force by the index and middle fingers of a user.

A needle retaining member **218** is disposed on the housing **204** for securing the needle **206**, which extends through the channel **212**, in the longitudinal member **202**. The arrangement of the channel **212** and the needle retaining member **218** secures the needle in position while not interfering with movement of the longitudinal member **202** during transition of the device from the use position to the non-use position.

In one embodiment, the housing **204** further includes first and second locking members **220a, 220b** that mechanically communicate with the first and second locking members **216a, 216b** of the longitudinal member **202**. In general, upon complete insertion of the longitudinal member **202** into the housing **204**, the housing locking members **220** align and interlock with the longitudinal member locking members **216**. In the non-use position, the longitudinal member **202** cannot be removed from the housing **204** to prevent re-use of the device and promote user safety.

FIGS. 8A-8C show the medical device **200** in the non-use position with the longitudinal member **202** fully inserted into housing **204** and the locking members **216, 220** engaged. The second housing portion **204b** includes a first piece **222a**, and a second piece **222b** that can pivot with respect to each other. In the non-use position, the first and second pieces **222** form an angle of about ninety degrees in one particular embodiment. The angled first and second pieces **222** extend outwardly from the first housing portion **204a** so as to envelope the needle **206**. That is, in the non-use position, the needle **206** does not protrude from the device **200**. A slot **224** (FIG. 7C) in the second housing portion

**204a** enables the first and second pieces **222** to pivot unencumbered by the needle **206**.

In one particular embodiment, the non-pivoting end of the first piece **222a** is coupled to the end **202a** of the longitudinal member. As force is applied to the longitudinal member **202** to force it into the housing **204**, movement of the longitudinal member **202** pivots the first piece **222a** with respect to the second piece **222b**. The non-pivoting end of the second piece **222b** is coupled to an end of the first housing portion **204a**.

In an exemplary embodiment, the second housing portion **204b** includes a series of ribs to create friction as the device **200** transitions to the non-use position during extraction of the needle **206** from the patient. As force is applied to the longitudinal member **202**, the pivoting first and second pieces **222** push against the patient to withdraw the needle **206**.

It is understood that the device dimensions can vary to meet the needs of a particular application. In one embodiment, the device has a length of about 2.3 inches and a height of about 1.5 inch in the non-use position. The device can have a width measure from ends of the wing portions of about 2.1 inches.

The inventive medical device shown and described herein can be fabricated from a variety of suitable materials well known to one of ordinary skill in the art. Exemplary materials include plastic, such as PVC, polyethylene, and the like.

One skilled in the art will appreciate further features and advantages of the invention based on the above-described embodiments. Accordingly, the invention is not to be limited by what has been particularly shown and described, except as indicated by the appended claims. All publications and references cited herein are expressly incorporated herein by reference in their entirety.

What is claimed is:

1. A medical device having a use position and a non-use position, comprising:

a housing having first and second housing portions and first and second locking members, the first and second housing portions each having respective first and second ends, and the second housing portion having a first position in the use position and a second position in the non-use position, wherein the second housing portion includes pivotably coupled first and second pieces such that the first and second pieces are generally planar in the use position and pivot to the non-use position;

a longitudinal member having first and second ends and first and second locking members, the longitudinal member extending from the housing in the use position and captured by the housing in the non-use position, wherein pressure on the first end of the longitudinal member toward the housing causes the first and second pieces of the second housing portion to pivot away from the longitudinal member to the non-use position, and wherein the housing locking members mechanically communicate with the longitudinal member locking members such that upon substantially complete insertion of the longitudinal member into the housing in the non-use position, the housing locking members substantially align and interlock with the longitudinal member locking members to substantially secure the longitudinal member to the housing; and

a needle extending from the device in the use position and not extending from the device in the non-use position, wherein the needle is captured by the housing in the non-use position.

2. The device according to claim 1, wherein the first end of the longitudinal member is coupled to the first end of the second housing portion.

3. The device according to claim 2, wherein the second end of the first housing portion is coupled to the second end of the second housing portion.

4. The device according to claim 1, wherein the second housing portion includes a slot for enabling transition of the device from the use position to the non-use position unencumbered by the needle.

5. The device according to claim 4, further including first and second wing portions extending from the housing to receive finger pressure from a user to transition the device from the use position to the non-use position.

6. The device according to claim 1, wherein the longitudinal member includes a channel to enable longitudinal movement of the longitudinal member unimpeded by the needle, wherein the needle extends through the channel.

7. The device according to claim 6, wherein the housing includes a needle retaining member to secure the needle in position in the longitudinal member.

8. The device according to claim 7, wherein the second housing portion includes a slot to enable a transition to the non-use position free of interference from the needle.

9. The device according to claim 7, further including first and second wing portions extending from the housing for receiving pressure from a user to promote transition of the device to the non-use position.

10. The device according to claim 9, wherein the first and second wing portions extend from the first housing portion and have an arcuate shape.

11. The device according to claim 1, wherein the longitudinal member slides into the housing.

12. The device according to claim 1, wherein the first and second pieces of the second housing portion push the device away from a patient in response to the pressure on the end of the longitudinal member as the device transitions from the use position to the non-use position.

13. The device according to claim 1, wherein the longitudinal member slides into the housing in the non-use position.

14. The device according to claim 1, wherein the first and second pieces of the second housing portion form an angle of about ninety degrees in the non-use position.

15. The device according to claim 1, wherein the first and second pieces of the second housing portion each have a first end that pivots relative to other piece of the second housing and a second end, wherein the second end of the first piece is coupled to the first end of the longitudinal member and the second end of the second piece is coupled to the second end of the first housing portion.

16. The device according to claim 1, wherein the second housing portion includes a series of ribs to create friction as the device transitions to the non-use position.

17. The device according to claim 1, wherein the device has a length of about 2.3 inches and a height of about 1.5 inch in the non-use position.

18. The device according to claim 1, wherein the device is fabricated from a plastic material.

19. A method of providing safety in medical device having a use position and a non-use position, comprising:

providing a housing for receiving a longitudinal member having first and second ends, first and second locking members, and a channel, the housing having first and second housing portions and first and second locking members, the first and second housing portions each having first and second ends;

connecting the first end of the first housing portion to the first end of the longitudinal member;

connecting the second end of the first housing portion to the second end of the second housing portion; and

affixing a needle to the device extending from the first housing portion through the channel in the use position; wherein axial pressure at the first end of the longitudinal member toward the housing in the use position forces the first and second housing portions to pivot and extend from the first housing portion and envelop the needle, and

wherein the housing locking members mechanically communicate with the longitudinal member locking members such that upon substantially complete insertion of the longitudinal member into the housing in the non-use position, the housing locking members substantially align and interlock with the longitudinal member locking members to substantially secure the longitudinal member to the housing.

20. The method according to claim 19, further including coupling first and second wing portions to the housing to receive finger pressure from a user to transition the device to the non-use position.

21. A method of removing a medical device needle from a patient and transitioning the device from a use position to a non-use position, comprising:

pressuring, in the use position, an end of a longitudinal member toward a housing, wherein the longitudinal member has first and second ends, first and second locking members, and a channel into the housing having first and second portions and first and second locking members, the first and second housing portions each having first and second ends such that the first and second portions extend at a pivot point to envelop a needle of the device as the device transitions to the non-use position,

wherein the housing locking members mechanically communicate with the longitudinal member locking members such that upon substantially complete insertion of the longitudinal member into the housing in the non-use position, the housing locking members substantially align and interlock with the longitudinal member locking members to substantially secure the longitudinal member to the housing.

22. The method according to claim 21, wherein the pivot point pushes the needle out of a patient's body.

23. A medical device, comprising:

a housing having first and second housing portions and first and second locking members, the first housing portion having first and second ends and the second housing portion having first and second ends, the second housing portion having pivotably coupled first and second pieces, the first housing portion extending along an axis;

a longitudinal member having first and second ends, a channel, and first and second locking members, the longitudinal member being movable from a use position in which the longitudinal member is extended from the housing along the axis and a non-use position in which the longitudinal member is captured by the first housing portion by pressuring the second end of a longitudinal member toward a housing, the first end of the second housing portion being connected to the first end of the longitudinal member and the second end of the first housing portion being connected to the second end of the second housing portion; and

a cavity arrangement formed in the housing portion,  
wherein the cavity arrangement is dimensioned to  
receive one or more needles,  
wherein the housing locking members mechanically com-  
municate with the longitudinal member locking mem- 5  
bers such that upon substantially complete insertion of  
the longitudinal member into the housing in the non-  
use position, the housing locking members substan-  
tially align and interlock with the longitudinal member  
locking members to substantially secure the longitudi- 10  
nal member to the housing.

24. The device according to claim 23, wherein the cavity  
arrangement is substantially arcuate.

25. The device according to claim 23, wherein the cavity  
arrangement enables an operator to apply steady pressure to 15  
the wing portions and the first member to ease extraction of  
the needle from the patient.

26. The device according to claim 23, wherein the needle  
is captured within the cavity arrangement when the device is  
transitioned to the non-use position. 20

\* \* \* \* \*