



- (51) International Patent Classification:
G06K 9/00 (2006.01)
- (21) International Application Number:
PCT/US2014/032367
- (22) International Filing Date:
31 March 2014 (31.03.2014)
- (25) Filing Language: English
- (26) Publication Language: English
- (30) Priority Data:
61/807,510 2 April 2013 (02.04.2013) US
- (71) Applicant: **3M INNOVATIVE PROPERTIES COMPANY** [US/US]; 3M Center, Post Office Box 33427, Saint Paul, Minnesota 55133-3427 (US).
- (72) Inventors: **BASTIAENS, Willem V.**; 3M Center, Post Office Box 33427, Saint Paul, Minnesota 55133-3427 (US). **BILLER, Gabriel A.**; 225 Terry Avenue North, Suite 300, Seattle, Washington 98109 (US). **CLOVER, Kristopher W.**; 3M Center, Post Office Box 33427, Saint Paul, Minnesota 55133-3427 (US). **HACKERSON, Brian R.**; 3M Center, Post Office Box 33427, Saint Paul, Minnesota 55133-3427 (US). **HENRY, Masuma W.**; 225 Terry Avenue North, Suite 300, Seattle, Washington 98109 (US).

JUNE, Stephen M.; 3M Center, Post Office Box 33427, Saint Paul, Minnesota 55133-3427 (US). **LINZIE, Brian L.**; 3M Center, Post Office Box 33427, Saint Paul, Minnesota 55133-3427 (US). **LORENTZ, Robert D.**; 3M Center, Post Office Box 33427, Saint Paul, Minnesota 55133-3427 (US). **MAHLI, David M.**; 3M Center, Post Office Box 33427, Saint Paul, Minnesota 55133-3427 (US). **MOORE, Richard J.**; 3M Center, Post Office Box 33427, Saint Paul, Minnesota 55133-3427 (US). **MORAN, Cristin E.**; 3M Center, Post Office Box 33427, Saint Paul, Minnesota 55133-3427 (US). **O'BRIEN, Michael E.**; 3M Center, Post Office Box 33427, Saint Paul, Minnesota 55133-3427 (US). **PEARSON, Scott D.**; 2700 Paces Ferry Road SE, Unit 802, Atlanta, Georgia 30339 (US). **POWELL, Dennard J.**; 3M Center, Post Office Box 33427, Saint Paul, Minnesota 55133-3427 (US). **RONNING, Olen**; 225 Terry Avenue North, Suite 300, Seattle, Washington 98109 (US). **SOMASUNDARAM, Guruprasad**; 3M Center, Post Office Box 33427, Saint Paul, Minnesota 55133-3427 (US). **STANKIEWICZ, Brian J.**; 3M Center, Post Office Box 33427, Saint Paul, Minnesota 55133-3427 (US). **WOLK, Diane R.**; 3M Center, Post Office Box 33427, Saint Paul, Minnesota 55133-3427 (US).

[Continued on next page]

(54) Title: SYSTEMS AND METHODS FOR MANAGING NOTES

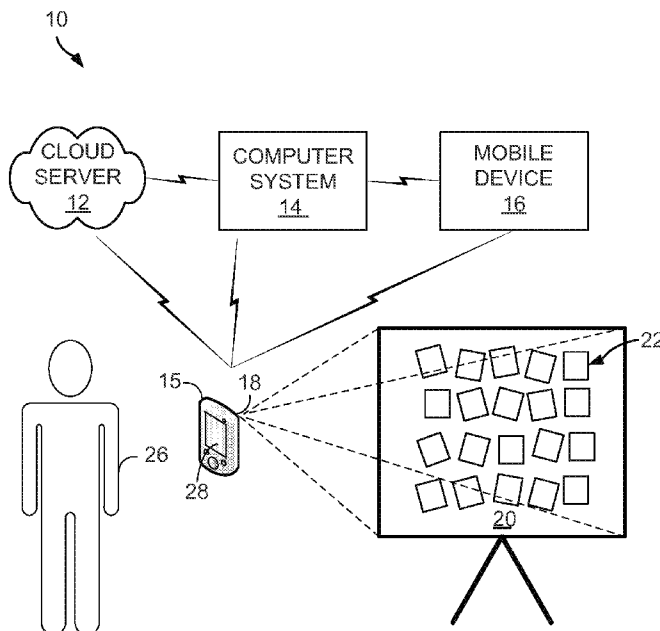

Fig. 1A

(57) Abstract: At least some aspects of the present disclosure feature systems and methods for managing notes. The note management system includes a note source, a note recognition module, a note extraction module, and a note labeling module. The note source is a visual representation of a scene having a note. The note recognition module is configured to receive the visual representation and determine a general boundary of the note from the visual representation. The note extraction module is configured to extract content of the note from the visual representation based on the determined general boundary. The note labeling module is configured to label the note with a category.



(74) **Agents:** HUANG, X., Christina et al.; 3M Center Office of Intellectual Property Counsel, Post Office Box 33427, Saint Paul, MN 55133-3427 (US).

(81) **Designated States** (unless otherwise indicated, for every kind of national protection available): AE, AG, AL, AM, AO, AT, AU, AZ, BA, BB, BG, BH, BN, BR, BW, BY, BZ, CA, CH, CL, CN, CO, CR, CU, CZ, DE, DK, DM, DO, DZ, EC, EE, EG, ES, FI, GB, GD, GE, GH, GM, GT, HN, HR, HU, ID, IL, IN, IR, IS, JP, KE, KG, KN, KP, KR, KZ, LA, LC, LK, LR, LS, LT, LU, LY, MA, MD, ME, MG, MK, MN, MW, MX, MY, MZ, NA, NG, NI, NO, NZ, OM, PA, PE, PG, PH, PL, PT, QA, RO, RS, RU, RW, SA, SC, SD, SE, SG, SK, SL, SM, ST, SV, SY, TH, TJ, TM, TN, TR, TT, TZ, UA, UG, US, UZ, VC, VN, ZA, ZM, ZW.

(84) **Designated States** (unless otherwise indicated, for every kind of regional protection available): ARIPO (BW, GH, GM, KE, LR, LS, MW, MZ, NA, RW, SD, SL, SZ, TZ, UG, ZM, ZW), Eurasian (AM, AZ, BY, KG, KZ, RU, TJ,

TM), European (AL, AT, BE, BG, CH, CY, CZ, DE, DK, EE, ES, FI, FR, GB, GR, HR, HU, IE, IS, IT, LT, LU, LV, MC, MK, MT, NL, NO, PL, PT, RO, RS, SE, SI, SK, SM, TR), OAPI (BF, BJ, CF, CG, CI, CM, GA, GN, GQ, GW, KM, ML, MR, NE, SN, TD, TG).

Declarations under Rule 4.17:

- as to applicant's entitlement to apply for and be granted a patent (Rule 4.17(ii))
- as to the applicant's entitlement to claim the priority of the earlier application (Rule 4.17(iii))

Published:

- with international search report (Art. 21(3))
- before the expiration of the time limit for amending the claims and to be republished in the event of receipt of amendments (Rule 48.2(h))

SYSTEMS AND METHODS FOR MANAGING NOTES

Technical Field

5 The present disclosure relates to note capturing, recognition, extraction, and/ or management tools and systems.

Background

10 Notes have been broadly used in recording, sharing, and communicating ideas and information. For example, during a collaboration session (e.g., brainstorming session), participants write down ideas on Post-It® notes, whiteboard, or paper, and then share with one another. In addition, people commonly use notes throughout the day to memorialize information or content which the individual does not want to forget. As additional examples, people frequently use notes as reminders of actions or events to take in the future, such as to make a telephone call, revise a document or to fill out a time sheet.

15 On many situations, people would traditionally write down the appropriate information on paper-based notes, such as Post-it® notes. Paper Post-it® notes are simply removed from a dispenser pad of sticky-back paper Post-it® notes, and are applied to various surfaces such as documents, the tops of desks, telephones, or the like. Information can be written on paper Post-it® notes either before or after the paper Post-it® notes are detached from their dispenser pad or attached to their target surfaces. Paper
20 Post-it® notes can be easily moved from one surface to another, such as between documents or between documents and the tops of desks, they can overlap edges or boundaries of documents, they can be layered, and they can be moved with the objects to which they are attached.

Summary

25 At least some aspects of the present disclosure feature a method of collecting content of notes, comprising the steps of: capturing, by a sensor, a visual representation of a scene having a plurality of notes; recognizing, by a processing unit, one of the plurality of notes from the visual representation; and extracting, by the processing unit, content of the one of the plurality of notes.

30 At least some aspects of the present disclosure feature a note recognition system including a sensor, a note recognition module, and a note extraction module. The sensor is configured to capture a visual representation of a scene having a plurality of notes. The note recognition module is coupled to the sensor. The note recognition module is configured to receive the captured visual representation and determine a general boundary of one of the plurality of notes from the captured visual representation. The note extraction module is configured to extract content of the one of the plurality of notes from the
35 captured visual representation based on the determined general boundary of the one of the plurality of notes.

Brief Description of the Drawings

The accompanying drawings are incorporated in and constitute a part of this specification and, together with the description, explain the advantages and principles of the invention. In the drawings,

5 Figure 1A is a representation illustrating one example of a user capturing an image of a workspace with notes using an image capture device on a mobile device;

Figure 1B is a block diagram illustrating one example of a mobile device;

Figure 1C illustrates an embodiment of a note recognition system;

Figure 1D illustrates an embodiment of a note management system;

10 Figures 2A-2C illustrate some examples of notes having marks;

Figure 3A illustrates a flow diagram of an embodiment of a note recognition and/or management system;

Figure 3B illustrates a flow diagram of an embodiment of extracting content of notes;

Figure 3C illustrates a flow diagram of an embodiment of authenticating a note;

15 Figures 4A – 4D illustrate an example of content extraction process of a note with a mark;

Figures 5A – 5D illustrate an embodiment of content extraction of a plurality of notes with retroreflective marks;

Figure 6 illustrates a module diagram of an embodiment of a note recognition system;

Figure 7A illustrates a flow diagram of an embodiment of a note management system;

20 Figure 7B illustrates examples of how a system may label a note; and

Figure 8 illustrates a module diagram of an embodiment of a note management system.

Detailed Description

Notes have been broadly used in recording, sharing, and communicating ideas and information. For example, during a collaboration session (e.g., brainstorming session), participants write down ideas on Post-It[®] notes, whiteboard, paper, and then share with one another. At least some aspects of the present disclosure are directed to systems and methods of capturing multiple notes and extracting content of notes. In some embodiments, at least some of the notes include a mark to facilitate the recognition and extraction of the notes. In some cases, the notes are captured and identified/recognized in one visual representation of a scene. A visual representation of a scene, for example, can be a digital photograph of note(s) and the surrounding environment. Further, at least some aspects of the present disclosure are directed to systems and methods of managing multiple notes, such as storing and retrieving the notes, categorizing and grouping the notes, or the like. In some cases, the note management system can improve the efficiency in capturing and extracting note content from a large number of notes. In addition, the note management system can improve the efficiency in grouping and managing notes.

Notes can include physical notes and digital notes. Physical notes generally refer to objects with a general boundary and recognizable content. Physical notes can include the resulting objects after people write, draw, or enter via other type of inputs on the objects, for example, paper, white board, or other objects accepting the inputs. By way of examples, physical notes can include hand-written Post-It[®] notes, paper, or film, white-board with drawings, posters, and signs. In some cases, one object can include several notes. For example, several ideas can be written on a piece of poster paper or a white-board. In some implementations, to facilitate the recognition of these notes, marks, such as lines, markers, stickers, can be applied to the edges of the notes. Physical notes can be two-dimensional or three dimensional. Physical notes can have various shapes and sizes. For example, a physical note may be a 3 inches x 3 inches note; a physical note may be a 26 inches x 39 inches poster; and a physical note may be a triangle metal sign. In some cases, physical notes have known shapes and/or sizes. Digital notes generally refer to digital objects with information and/or ideas. Digital notes can be generated using digital inputs. Digital inputs can include, for example, keyboards, touch screens, digital cameras, digital recording devices, stylus, digital pens, or the like.

In some cases, notes are used in a collaboration space. Collaboration space generally refers to a gathering area allowing more than one person to share ideas and thoughts with each other. The collaboration space can include virtual space allowing a group of persons to share ideas and thoughts remotely, besides the gathering area.

Figure 1A illustrates an example of a note recognition environment **10**. In the example of Figure 1A, environment **10** includes a mobile device **15** to capture and recognize one of more notes **22** from a workspace **20**. As described herein, mobile device provides an execution environment for one or more software applications that, as described, can efficiently capture and extract note content from a large number of physical notes, such as the collection of notes **22** from workspace **20**. In this example, notes **22** may be the results of a collaborative brainstorming session having multiple participants. As described, mobile device **15** and the software executing thereon may perform a variety of note-related operations, including automated creation of digital notes representative of physical notes **22** of workspace **20**.

In the example implementation, mobile device **15** includes, among other components, an image capture device **18** and a presentation device **28**. In addition, although not shown in Figure 1A, mobile device **15** may include one or more processors, microprocessors, internal memory and/or data storage and other electronic circuitry for executing software or firmware to provide the functionality described herein.

In general, image capture device **18** is a camera or other component configured to capture image data representative of workspace **20** and notes **22** positioned therein. In other words, the image data captures a visual representation of an environment, such as workspace **20**, having a plurality of visual notes. Although discussed as a camera of mobile device **15**, image capture device **18** may comprise other components capable of capturing image data, such as a video recorder, an infrared camera, a CCD (Charge Coupled Device) array, a laser scanner, or the like. Moreover, the captured image data can

include at least one of an image, a video, a sequence of images (i.e., multiple images taken within a time period and/or with an order), a collection of images, or the like, and the term input image is used herein to refer to the various example types of image data.

Presentation device **28** may include, but not limited to, an electronically addressable display, such as a liquid crystal display (LCD) or other type of display device for use with mobile device **28**. In some implementations, mobile device **15** generates the content to display on presentation device **28** for the notes in a variety of formats, for example, a list, grouped in rows and/or column, a flow diagram, or the like. Mobile device **15** may, in some cases, communicate display information for presentation by other devices, such as a tablet computer, a projector, an electronic billboard or other external device.

As described herein, mobile device **15**, and the software executing thereon, provide a platform for creating and manipulating digital notes representative of physical notes **22**. For example, in general, mobile device **15** is configured to process image data produced by image capture device **18** to detect and recognize at least one of physical notes **22** positioned within workspace **20**. In some examples, the mobile device **15** is configured to recognize note(s) by determining the general boundary of the note(s). After a note is recognized, mobile device **15** extracts the content of at least one of the one or more notes, where the content is the visual information of note **22**.

As further described below, mobile device **15** may implement techniques for automated detection and recognition of physical notes **22** and extraction of information, content or other characteristics associated with each of the physical notes.

In the example of Figure 1A, mobile device **15** is illustrated as a mobile phone. However, in other examples, mobile device **15** may be a tablet computer, a personal digital assistant (PDA), a laptop computer, a media player, an e-book reader, a wearable computing device (e.g., a watch, eyewear, a glove), or any other type of mobile or non-mobile computing device suitable for performing the techniques described herein.

Figure 1B illustrates a block diagram illustrating an example of a mobile device that operates in accordance with the techniques described herein. For purposes of example, the mobile device of Figure 1B will be described with respect to mobile device **15** of Figure 1A

In this example, mobile device **15** includes various hardware components that provide core functionality for operation of the device. For example, mobile device **15** includes one or more programmable processors **70** configured to operate according to executable instructions (i.e., program code), typically stored in a computer-readable medium or data storage **68** such as static, random-access memory (SRAM) device or Flash memory device. I/O **76** may include one or more devices, such as a keyboard, camera button, power button, volume button, home button, back button, menu button, or presentation device **28** as described in Figure 1A. Transmitter **72** and receiver **74** provide wireless communication with other devices, such as cloud server **12**, computer system **14**, or other mobile device **16** as described in Figure 1A, via a wireless communication interface as described in Figure 1A, such as

but not limited to high-frequency radio frequency (RF) signals. Mobile device **15** may include additional discrete digital logic or analog circuitry not shown in Figure 1B.

In general, operating system **64** executes on processor **70** and provides an operating environment for one or more user applications **77** (commonly referred to “apps”), including note management application **78**. User applications **77** may, for example, comprise executable program code stored in computer-readable storage device (e.g., data storage **68**) for execution by processor **70**. As other examples, user applications **77** may comprise firmware or, in some examples, may be implemented in discrete logic.

In operation, mobile device **15** receives input image data and processes the input image data in accordance with the techniques described herein. For example, image capture device **18** may capture an input image of an environment having a plurality of notes, such as workspace **20** of Figure 1A having of notes **22**. As another example, mobile device **15** may receive image data from external sources, such as cloud server **15**, computer system **14** or mobile device **16**, via receiver **74**. In general, mobile device **15** stores the image data in data storage **68** for access and processing by note management application **78** and/or other user applications **77**.

As shown in Figure 1B, user applications **77** may invoke kernel functions of operating system **64** to output a graphical user interface (GUI) **79** for presenting information to a user of mobile device. As further described below, note management application **78** may construct and control GUI **79** to provide an improved electronic environment for generating and manipulating corresponding digital notes representative of physical notes **22**.

To better understand the present disclosure, Figure 1C illustrates an embodiment of a note recognition system **100A**. The system **100A** can include a processing unit **110**, one or more notes **120**, a sensor **130**, and note content repository **140**. The processing unit **110** can include one or more processors, microprocessors, computers, servers, and other computing devices. The sensor **130**, for example, an image sensor, is configured to capture a visual representation of a scene having the one or more notes **120**. The sensor **130** can include at least one of a camera, a video recorder, an infrared camera, a CCD (Charge Coupled Device) array, a scanner, or the like. The visual representation can include at least one of an image, a video, a sequence of images (i.e., multiple images taken within a time period and/or with an order), a collection of images, or the like. The processing unit **110** is coupled to the sensor **130** and configured to receive the visual representation. In some cases, the processing unit **110** is electronically couple to the sensor **130**. The processing unit **110** is configured to recognize at least one of the one or more notes **120** from the visual representation. In some embodiments, the processing unit **110** is configured to recognize note(s) by determining the general boundary of the note(s). After a note is recognized, the processing unit **110** extracts the content of the note. In some cases, the processing unit **110** is configured to recognize and extract the content of more than one note from a visual representation of a scene having those notes.

In some cases, the processing unit **110** can execute software or firmware stored in non-transitory computer-readable medium to implement various processes (e.g., recognize notes, extract notes, etc.) for the system **100A**. The note content repository **140** may run on a single computer, a server, a storage device, a cloud server, or the like. In some other cases, the note content repository **140** may run on a series of networked computers, servers, or devices. In some implementations, the note content repository **140** includes tiers of data storage devices including local, regional, and central. The notes **120** can include physical notes arranged orderly or randomly in a collaboration space and the sensor **130** generates a visual representation of the notes **120** in the collaboration space.

In some embodiments, at least some of the one or more notes **120** include a mark, which can facilitate the identification, recognition, and/or authentication of a note. In some embodiments, a mark includes at least one of a barcode, a color block, a color code, a fiduciary mark, a trademark logo, a dot, a hole, and the like. The shape and/or color of the note itself may be used as the mark to facilitate the identification, recognition, and/or authentication of a note. In some cases, the mark can include a plurality of elements arranged in certain patterns, for example, fiduciary marks at four corners of a rectangular note. In some other cases, the mark can include a plurality of elements, where at least some elements are non-visible elements that can be used to provide authentication information, for example, RFID (radio frequency identification) tags. By way of example, a mark can be made using at least one of a retroreflective material, an optically variable ink, a colored ink, infrared absorbing ink, fluorescent ink, watermark, glossy material, iridescent material, multi-layer optical film, colloidal crystals, perforated marks, structured color, floating image, window thread, or the like. In some embodiments, the processing unit **110** first recognizes the mark on a note from a visual representation, determines the location of the mark on the visual representation, and then extracts the content of the note based on the recognized mark. In some cases, the processing unit **110** extracts the content of the note based upon the recognized mark, a known shape of the note, and a known relative position of the mark on the note. In some implementations, the processing unit **110** extracts the content of the note from the visual representation in real-time (i.e., process the data in a transitory storage) without storing the visual representation in a non-transitory storage.

In some implementations, the note recognition system **100A** can include a presentation device (not shown in Figure 1C) to show to the user which notes are recognized and/or which notes' content have been extracted. Further, the note recognition system **100A** can present the extracted content via the presentation device. In some embodiments, the processing unit **110** can authenticate a note before extracting the content of the note. If the note is authenticated, the content will be extracted and stored in the note content repository **140**. In some cases, the processing unit can extract the authentication information from the mark on the note. In such cases, the authentication information can be visible or non-visible on the mark. For example, the mark on a note can include a symbol, for example, a company logo, a matrix code, a barcode, a color code, or the like. As another example, the mark on the note can

include a tag to store information that can be retrieved by a suitable reader. For example, the mark can include a RFID tag, a near field communication (NFC) tag, or the like.

In some embodiments, the sensor **130** can generate a first visual representation of a scene having several notes **120**, for example, taking a photograph or a video clip of the notes with the surrounding environment. Each of the notes has a mark. The processing unit **110** identifies the marks, determines the location of the marks, and uses the location of the marks to control the sensor **130** to generate a second visual representation of the scene having the notes **120**, for example, taking a zoomed-in image of the notes. The processing unit **110** can further recognize and extract content of notes from the second visual representation.

Figure 1D illustrates an embodiment of a note management system **100B**. In this embodiment, the note management system **100B** includes processing unit **110**, one or more notes **120**, one or more note sources **150**, and a note content repository **140**. In some cases, the system **100B** includes a presentation device **160**. The processing unit **110**, the notes **120**, and the note content repository **140** are similar to the components for the note recognition system **100A** as illustrated in Figure 1A. The note sources **150** can include sources to provide content of physical notes, such as a visual representation of a scene having one or more notes, and sources to provide content of digital notes, such as a data stream entered from a keyboard. In some embodiments, the note management system **100B** includes a first source and a second source, and the first source is a visual representation of a scene having one or more notes **120**. The first source and the second source are produced by different devices. The second source includes at least one of a text stream, an image, a video, a file, and a data entry. The processing unit **110** recognizes at least one of the notes from the first source and extracts the content of the note, as discussed in the note recognition system **100A**. In some cases, the processing unit **110** labels the note with a category. The processing unit **110** can label a note based on its specific shape, color, content, and/or other information of the note. For example, each group of note can have a different color (e.g., red, green, yellow, etc.). In some cases, a note **120** can include mark that has one or more elements and the processing unit **110** can label the note based on information extracted from the mark.

In some embodiments, the note management system **100B** can include one or more presentation devices **160** to show the content of the notes **120** to the user. The presentation device **160** can include, but not limited to, an electronically addressable display, such as a liquid crystal display (LCD), a tablet computer, a projector, an electronic billboard, a cellular phone, a laptop, or the like. In some implementations, the processing unit **110** generates the content to display on the presentation device **160** for the notes in a variety of formats, for example, a list, grouped in rows and/or column, a flow diagram, or the like.

Various components of the note recognition system and note management system, such as processing unit, image sensor, and note content repository, can communicate via a communication interface. The communication interface includes, but not limited to, any wired or wireless short-range

and long-range communication interfaces. The short-range communication interfaces may be, for example, local area network (LAN), interfaces conforming to a known communications standard, such as Bluetooth standard, IEEE 802 standards (e.g., IEEE 802.11), a ZigBee or similar specification, such as those based on the IEEE 802.15.4 standard, or other public or proprietary wireless protocol. The long-range communication interfaces may be, for example, wide area network (WAN), cellular network interfaces, satellite communication interfaces, etc. The communication interface may be either within a private computer network, such as intranet, or on a public computer network, such as the internet.

Figures 2A-2C illustrate some examples of notes having marks. As illustrated in Figure 2A, the mark on the note **200A** has two elements, element **210A** and element **220A**. The elements **210A** and **220A** can have different size, shape, relative position and/or material composition. For example, element **210A** is a barcode as an identifier for the note and element **220A** is a small rectangle of retro-reflective ink that can be used to determine the boundary of the note. As illustrated in Figure 2B, the mark on the note **200B** can have four elements **210B**, **220B**, **230B**, and **240B**. The four elements may have similar or different sizes, shapes, and material compositions. The mark can be used to recognize the size, location, orientation, distortion, and other characteristics of the note, which can be used in content extraction and enhancement. As illustrated in Figure 2C, the mark on the note **200C** has one element **210C**. The note **200C** has a non-rectangular shape. In some embodiments, the element **210C** includes an identifier, for example, to identify the types and the grouping for a note. In some cases, the identifier is a unique identifier.

Figure 3A illustrates a flow diagram of an embodiment of a note recognition and/or management system. Initially, the system captures a visual representation of plurality of notes (step **310A**). In some embodiments, the notes are physical notes and it is more efficient to capture more than one note at a time. Next, the system recognizes one of the plurality of notes from the visual representation (step **320A**). For example, the system can recognize a specific mark on a note and subsequently determine the general boundary of the note. The system extracts content of the one of the plurality of notes (step **330A**). In some embodiments, the system can apply image transformation to at least part of the visual representation before extracting content. In some other embodiments, the system can apply image enhancement or other image processing technique to improve the quality of the extracted content. In yet other embodiments, the system can further recognize text and figures from the extracted content.

Figure 3B illustrates a flow diagram of an embodiment of extracting content of notes. First, a visual representation is received by the system (step **310B**). The system recognizes a mark on a note from the visual representation (step **320B**). After the position and/or shape of the mark is determined, the system may optionally perform geometric correction and cropping to the visual representation (step **330B**). Based on the recognized position and/or shape of the mark on the note, the general boundary of the note is recognized on the visual presentation (step **340B**). In some embodiments, the system may receive two visual representations of the same set of notes, where each of the notes has a mark. The first

visual representation is taken using a light source suitable to capture the marks on the notes. For example, the light source can be infrared light for marks using infrared sensitive ink. The marks are recognized in the first visual representation and the positions of the marks are determined. The second visual representation can capture the set of notes and the system can determine the general boundary of each note based on its mark respectively. After the general boundary of a note is determined, the system extracts the content of the note (step **350B**). For example, where the visual representation is an image, the system may crop the image according to the determined general boundary of the note. Optionally, the system may enhance the content of the note (step **360B**), for example, by changing the contrast, brightness, and/or using other image processing techniques. In some cases, the system may update the note with a status indicating its content extracted.

Figure 3C illustrates a flow diagram of an embodiment of authenticating a note. First, obtain an authentication signal from a note or a stack of notes (step **310C**). In one embodiment, the authentication information is a visual component (e.g., a hologram) of a mark on a note and the authentication signal can be obtained by extracting the visual component from a visual representation capturing the note. In another embodiment, the authentication information is contained in an electronic component (e.g., a RFID tag) of a mark on a note and the authentication signal can be obtained using a suitable reader (e.g., a RFID reader). Next, the system verifies the authentication signal (step **320C**). The system can start the note management application or use the note(s) if the note(s) are authenticated (step **330C**).

Figures 4A – 4D illustrate an example of content extraction process of a note with a mark. First, as illustrated in Figure 4A, a visual representation **400** of a note **410** is captured. The note **410** has a mark **420**, which can be a barcode, a color code, a matrix code, a color block, or the like. Next, as illustrated in Figure 4B, the system determines the general boundary **430** of the mark on the visual representation and recognizes the mark **420**. In some cases, the note **410** may be slanted in the visual representation **400**, as illustrated in Figure 4C. In some other cases, the visual representation **400** may be taken with geometric distortion. The system may use the determined general boundary of the mark **420** or a portion of the mark **420** to determine the necessary image transformation and correction to the visual representation **400** to obtain the note content. Figure 4D illustrates that the system extracts the content of the note **410** after the previous analysis and/or image processing.

Figures 5A – 5D illustrate an embodiment of content extraction of a plurality of notes with retroreflective marks. A note recognition/management system receives a visual representation **500A**, which captures three notes **510A**, and each note **510A** has a mark **520** has two elements – two retroreflective rectangular tags at upper left and lower bottom corners. Because of the optical property of the retroreflective material, the mark **520** is substantially brighter than the rest of the note. Figure 5B illustrates the marks **520** are much brighter than the notes **510A** and the background. In some embodiments, the system may use image processing to transform the visual representation of 500A as illustrated in Figure 5A to 500B as illustrated in Figure 5B. In some alternative embodiments, the system

may generate another visual representation **500B** of the three notes **510A** with a different light source, for example, a flash light. The system can easily identify the marks **520** from the visual representation **500B**. After the marks **520** are identified, the system can extract the content of the notes **510C**, as illustrated in Figure 5C. In some cases, the system may use image processing technique (e.g., adaptive histogram equalization) to enhance the extracted content **510D**, as illustrated in Figure 5D.

Figure 6 illustrates a module diagram of an embodiment of a note recognition system **600**. In the embodiment as illustrated, the system **600** includes a note capturing module **620**, a note recognition module **630**, and a note extraction module **640**. Various components of the note recognition system **600** can be implemented by one or more computing devices, including but not limited to, circuits, a computer, a processor, a processing unit, a microprocessor, and/or a tablet computer. In some cases, various components of the note recognition system **600** can be implemented on a shared computing device. Alternatively, a component of the system **600** can be implemented on multiple computing devices. In some implementations, various modules and components of the system **600** can be implemented as software, hardware, firmware, or a combination thereof. In some cases, various components of the note recognition system **600** can be implemented in software or firmware executed by a computing device. Additionally, various components of the system **600** can communicate via or be coupled to via a communication interface, for example, a wired or wireless interface. The note capturing module **620** is configured to capture a visual representation of a plurality of physical notes. In some embodiments, the note capturing module **620** includes an image sensor. The note recognition module **630** is coupled to the note capturing module **620**, the note recognition module is configured to receive the captured visual representation and determine a general boundary of one of the plurality of physical notes from the captured visual representation. In some cases, the note recognition module **630** is configured to create a digital note representative the recognized physical note. The note extraction module **640** is configured to extract content of the one of the plurality of notes from the captured visual representation based on the determined general boundary of the one of the plurality of notes. In some cases, the note extraction module **640** is configured to associate the extracted content with the corresponding digital note.

In some embodiments, the note recognition system **600** includes a note authentication module **650** configured to authenticate the plurality of notes. In some cases, at least some of the plurality of notes have a mark. The mark can be used to facilitate the recognition, extraction and authentication of the note. For example, the note authentication module **650** can obtain an authentication signal from a mark of a note and verify the authentication based on the authentication signal. In some cases, the note authentication module **650** is coupled to the note recognition module **630** and provides the authentication information to the note recognition module **630**. In some embodiments, the note recognition module **630** and the note extraction module **640** can perform the steps illustrated in Figure 3B and in the relevant discussions.

In some embodiments, a note recognition/management system may use multiple recognition algorithms to recognize notes and extract notes' content, such as color recognition, shape recognition, and pattern recognition. For example, the system may use color spaces such as the RGB, HSV, CIELAB, etc. to identify regions of interest corresponding to the notes for color recognition. In some cases, the notes are further distinguished in their shape and due to the presence of unique patterns detected by shape recognition (e.g., Hough transform, shape context, etc.) and pattern recognition algorithms (e.g., Support Vector Machine, cross-correlation, template matching, etc.) respectively. These algorithms help filter out unwanted objects in the visual representation or other sources of notes' content and leave only those regions of interest corresponding to the notes.

In an embodiment, a note may include a mark made using fluorescent materials, such as printable inks or coatable dyes. For example, a fiducial mark such as a logo can be printed in fluorescent ink on the writing surface of a note. An appropriate light source would excite the fluorescent material. For example, a white LED (light emitting diode) of a mobile handheld device may be able to excite the fluorophore using the significant blue wavelength component of the LED output spectrum. In one embodiment, a fluorescent dye can be coated on the writing surface of the notes or included in the materials making the notes. In this embodiment, the fluorescent dye can provide not only verification of a branded product but can also improve the contrast between the written information on the note and the background of the note itself. Such mark can facilitate the recognition and segmentation of notes on a visual representation produced by an image sensor. In the cases of notes made from paper with fluorescent dye, the captured visual representation may have better readability. Depending on the excitation wavelength range and the fluorescing wavelength range for the fluorescent materials, additional optical equipment, such as a filter, may be used together with an image sensor (e.g., a camera) to improve detection.

Figure 7A illustrates a flow diagram of an embodiment of a note management system. First, the system receives a plurality of notes from multiple sources (step 710A). For example, the note management system may receive a set of images of a number of notes from a camera or a smart phone and receive another set of images of a number of notes taken from a remote location. As another example, the note management system may receive a visual representation (e.g., a video) of a number of notes taken by a video recording device and a text stream of notes that is entered via a laptop. In some embodiments, the multiple sources are sources of notes' content taken from different devices, for example, cameras, scanners, computers, etc. Then, the system recognizes one of the plurality of notes (step 720A). In some cases, the system creates digital notes representative of the one of the plurality of physical notes, The system extracts content of the plurality of notes (step 730A). In some cases, the system associates the extracted content with the corresponding digital notes representative of physical notes. In some embodiments, some notes include marks (e.g., color block, color code, barcode, etc.) on the note and one source of notes is a visual representation of some of the notes. In some cases, the recognizing step includes recognizing marks on the notes from the visual representation and then

determines the general boundaries of the notes based on the recognized marks. In some of these cases, the extracting step includes extracting the content based upon the recognized marks, known shapes of the notes, and known relative positions of the marks on the notes. After the content of the plurality of notes is extracted, in some cases, the system may associate each of the plurality of digital notes with a unique identifier (step **740A**). The system may label each of the plurality of digital notes with a category (step **750A**). The labeling step is discussed in more details below. Additionally, the system may first authenticate the notes before recognizing the notes. Optionally, the system may present the content of the plurality of notes on a display (step **760A**). In some embodiments, the system may present the extracted content of the plurality of notes with an output field indicating the categories of the notes. In some implementations, the system may use the category information of the digital notes in presenting the digital notes (e.g., show the notes in one category in a group).

Figure 7B illustrates examples of how a system may label a digital note. In one embodiment, a note management system can label a note based on a detected signal (**710B**). For example, a note can have a mark including a barcode; the system can read the barcode and label the note based on the barcode. In some cases, the system can label a note based on a recognized mark (**720B**). For example, the mark can include an icon, logo, or other graphical symbol indicating a particular group. The system may further label a note based on its content (**730B**). In some cases, the system may label a note based on historical data and/or predictive modeling (**740B**). In some other cases, the system may label a note by user input (**750B**). A note management system can use one or more approaches to label a note. The system may also use other approaches to label a note that are not listed in Figure 7B, for example, label a note based on the shape of the note. Further, in some cases, a note may be associated with more than one category.

Figure 8 illustrates a module diagram of a note management system **800**. In the embodiment as illustrated, the system **800** includes one or more note sources **820**, a note recognition module **830**, a note extraction module **840**, and a note labeling module **860**. Various components of the note management system **800** can be implemented by one or more computing devices, including but not limited to, circuits, a computer, a processor, a processing unit, a microprocessor, and/or a tablet computer. In some cases, various components of the note management system **800** can be implemented on a shared computing device. Alternatively, a component of the system **800** can be implemented on multiple computing devices. In some implementations, various modules and components of the system **800** can be implemented as software, hardware, firmware, or a combination thereof. In some cases, various components of the note management system **800** can be implemented in software or firmware executed by a computing device. Additionally, various components of the system **800** can communicate via or be coupled to via a communication interface, for example, a wired or wireless interface. The note source(s) **820** is configured to provide a plurality of notes. In some embodiments, one of the note sources **820** is a visual representation of a scene having one or more physical notes. In some cases, the note sources **820** include a plurality of different sources for providing notes, for example, images, text stream, video

stream, or the like. The note recognition module **830** is coupled to the note sources **820**, the note recognition module is configured to receive the visual representation, determine a general boundary of a physical note from the visual representation and create a digital note representative of the physical note. The note extraction module **840** is configured to extract content of the one of the plurality of physical notes from the visual representation based on the determined general boundary of the one of the plurality of physical notes and associate the extracted content with the corresponding digital notes.. The note labeling module **860** is configured to label the one of the plurality of digital notes with a category.

In some embodiments, the note management system **800** includes a note authentication module **850** is configured to authenticate the plurality of notes. In some cases, at least some of the plurality of notes have a mark. The mark can be used to facilitate the recognition, extraction and authentication of the note. For example, the note authentication module **850** can obtain an authentication signal from a mark of a note and verify the authentication based on the authentication signal. In some cases, the note authentication module **850** is coupled to the note recognition module **830** and provides the authentication information to the note recognition module **830**. In some embodiments, the note recognition module **830** and the note extraction module **840** can perform the steps illustrated in Figure 3B and in the relevant discussions. In some embodiments, the note labeling module **860** can use one or more labeling approaches illustrated in Figure 7B and in the relevant discussions. In some cases, a note may be associated with more than one category.

In some embodiments, the note management system **800** may include a note presentation module **870**, which is configured to gather content of the plurality of digital notes and present at least part of the plurality of notes according to the category of the notes. For example, the note presentation module **870** can organize the plurality of digital notes into groups that have the same category. As another example, the note presentation module **870** can add connection lines and/or arrows of different groups of digital notes.

Exemplary Embodiments

Embodiment 1. A method of managing notes, comprising:

providing a plurality of notes from a first source and a second source, the first source and the second source being produced from different devices, the first source being a visual representation of a scene having one or more of the plurality of notes;

recognizing, by a processing unit, one of the plurality of notes from the first source;

extracting, by the processing unit, content of the one of the plurality of notes;

creating, by the processing unit, a plurality of digital notes, each digital note representative one of the plurality of notes; and

labeling the digital note provided by the first source and the second source with a category.

Embodiment 2. The method of Embodiment 1, wherein the second source comprises at least one of a text stream, an image, a video, a file, and a data entry.

5 Embodiment 3. The method of Embodiment 1 or Embodiment 2, further comprising:
associating the digital note with a unique identifier.

Embodiment 4. The method of any one of the Embodiment 1 through Embodiment 3, wherein the labeling step comprises labeling the digital note based on the extracted content.

10

Embodiment 5. The method of any one of the Embodiment 1 through Embodiment 4, wherein the labeling step comprises labeling the digital note by a user.

15

Embodiment 6. The method of Embodiment 3, wherein the labeling step comprises labeling the digital note based on the unique identifier.

Embodiment 7. The method of any one of the Embodiment 1 through Embodiment 6, wherein the one of the plurality of notes comprises a mark.

20

Embodiment 8. The method of Embodiment 7, wherein the mark comprises at least one of a barcode, a color block, a color code, a pattern, a fiducial mark, a trademark logo, a dot, and a hole.

Embodiment 9. The method of Embodiment 7 or Embodiment 8, wherein the recognizing step comprises recognizing the mark of the one of the plurality of notes from the visual representation.

25

Embodiment 10. The method of Embodiment 9, wherein the recognizing step comprises determining the general boundary of the one of the plurality of notes based upon the recognized mark.

30

Embodiment 11. The method of Embodiment 9, wherein the recognizing step comprises determining the general boundary of the one of the plurality of notes based upon the recognized mark, a known shape of the one of the plurality of notes, and a known relative position of the mark on the one of the plurality of notes.

35

Embodiment 12. The method of Embodiment 7, wherein the mark comprises a symbol.

Embodiment 13. The method of Embodiment 12, wherein the extracting step comprises extracting the symbol from the visual representation.

Embodiment 14. The method of Embodiment 13, further comprising:
5 authenticating the one of the plurality of notes based on the extracted symbol.

Embodiment 15. The method of Embodiment 9, wherein the labeling step comprises labeling the digital note based on the recognized mark.

10 Embodiment 16. The method of Embodiment 13, wherein the labeling step comprises labeling the digital note based on the extracted symbol.

Embodiment 17. The method of any one of the Embodiment 1 through Embodiment 16, wherein the plurality of notes comprises physical notes, digital notes, and a combination thereof.

15

Embodiment 18. The method of any one of the Embodiment 1 through Embodiment 17, wherein the processing unit comprises at least one of a processor, a microprocessor, a microcontroller, a computer, and a computing device.

20 Embodiment 19. The method of any one of the Embodiment 1 through Embodiment 18, further comprising:
presenting, by a presentation device, the extracted content to a user.

Embodiment 20. The method of Embodiment 19, wherein the presenting step comprises
25 presenting the extracted content with an output field indicating the category of the digital note.

Embodiment 21. The method of Embodiment 7, wherein the mark is made using at least one of a retroreflective material, an optically variable ink, a colored ink, infrared absorbing ink, fluorescent ink, watermark, glossy material, iridescent material, perforated marks, structured color, floating image, and
30 window thread.

Embodiment 22. The method of any one of the Embodiment 1 through Embodiment 21, further comprising:

35 authenticating, by the processing unit, the one of the plurality of notes,
wherein the extracting step comprises extract the content of the one of the plurality of notes if the one of the plurality of notes is authenticated.

Embodiment 23. The method of any one of the Embodiment 1 through Embodiment 22, wherein the visual representation is an image or a video.

5 Embodiment 24. The method of any one of the Embodiment 1 through Embodiment 23, wherein the labeling step comprises labeling the digital note based on extracted content and historical data.

Embodiment 25. The method of any one of the Embodiment 1 through Embodiment 24, wherein the labeling step comprises labeling the digital note based on the extracted content, historical data, and
10 predictive modeling.

Embodiment 26. A note management system, comprising:

a first note source and a second note source configured to provide a plurality of notes, the first note source and the second note source being produced from different devices, the first note source being
15 a visual representation of a scene having one or more of the plurality of notes,

a note recognition module configured to receive the visual representation and determine a general boundary of one of the plurality of notes from the visual representation,

a note extraction module configured to extract content of the one of the plurality of notes from the visual representation based on the determined general boundary of the one of the plurality of notes and
20 create a digital note associated with the one of the plurality of notes and the extracted content, and

a note labeling module configured to label the digital note with a category.

Embodiment 27. The note management system of Embodiment 26, wherein the second note source comprises at least one of a text stream, an image, a video, a file, and a data entry.

25

Embodiment 28. The note management system of Embodiment 26 or Embodiment 27, wherein the note extraction module is further configured to associate the digital note with a unique identifier.

Embodiment 29. The note management system of any one of Embodiment 26 through
30 Embodiment 28, wherein the note labeling module is further configured to label the digital note based on the extracted content.

Embodiment 30. The note management system of any one of Embodiment 26 through
Embodiment 29, wherein the labeling step comprises labeling the digital note by a user.

35

Embodiment 31. The note management system of Embodiment 28, wherein the labeling step comprises labeling the digital note based on the unique identifier.

5 Embodiment 32. The note management system of any one of Embodiment 26 through Embodiment 31, wherein the one of the plurality of notes comprises a mark.

10 Embodiment 33. The note management system of Embodiment 32, wherein the mark comprises at least one of a barcode, a color block, a color code, a pattern, a fiduciary mark, a trademark logo, a dot, and a hole.

Embodiment 34. The note management system of Embodiment 33, wherein the note recognition module is further configured to recognize the mark of the one of the plurality of notes from the visual representation.

15 Embodiment 35. The note management system of Embodiment 34, wherein the note recognition module is further configured to determine the general boundary of the one of the plurality of notes based upon the recognized mark.

20 Embodiment 36. The note management system of Embodiment 34, wherein the note recognition module is further configured to determine the general boundary of the one of the plurality of notes based upon the recognized mark, a known shape of the one of the plurality of notes, and a known relative position of the mark on the one of the plurality of notes.

25 Embodiment 37. The note management system of Embodiment 32, wherein the mark comprises a symbol.

Embodiment 38. The note management system of Embodiment 37, wherein the note extraction module is further configured to extract the symbol from the visual representation.

30 Embodiment 39. The note management system of Embodiment 38, further comprising:
a note authentication module configured to authenticate the one of the plurality of notes based on the extracted symbol.

35 Embodiment 40. The note management system of Embodiment 34, wherein the note labeling module is further configured label the digital note based on the recognized mark.

Embodiment 41. The note management system of Embodiment 38, wherein the note labeling module is further configured to label the digital note based on the extracted symbol.

5 Embodiment 42. The note management system of any one of Embodiment 26 through Embodiment 41, wherein the plurality of notes comprises physical notes, digital notes, and a combination thereof.

10 Embodiment 43. The note management system of any one of Embodiment 26 through Embodiment 42, wherein the processing unit comprises at least one of a processor, a microprocessor, a microcontroller, a computer, and a computing device.

Embodiment 44. The note management system of any one of Embodiment 26 through Embodiment 43, further comprising:
a note presentation module configured to present the extracted content to a user.

15 Embodiment 45. The note management system of Embodiment 44, wherein the note presentation module is further configured to present the extracted content with an output field indicating the category of the digital note associated with the extracted content.

20 Embodiment 46. The note management system of Embodiment 32, wherein the mark is made using at least one of a retroreflective material, an optically variable ink, a colored ink, infrared absorbing ink, fluorescent ink, watermark, glossy material, iridescent material, perforated marks, structured color, floating image, and window thread.

25 Embodiment 47. The note management system of any one of Embodiment 26 through Embodiment 46, further comprising:
a note authentication module configured to authenticate the one of the plurality of notes,
wherein the note extraction module is further configured to extract the content of the one of the plurality of notes if the one of the plurality of notes is authenticated.

30 Embodiment 48. The note management system of any one of Embodiment 26 through Embodiment 47, wherein the visual representation is an image or a video.

35 Embodiment 49. The note management system of any one of Embodiment 26 through Embodiment 48, wherein the note labeling module is further configured to label the digital note based on the extracted content and historical data.

Embodiment 50. The note management system of any one of Embodiment 26 through Embodiment 49, wherein the note labeling module is further configured to label the digital note based on the extracted content, historical data, and predictive modeling.

5

The present invention should not be considered limited to the particular examples and embodiments described above, as such embodiments are described in detail to facilitate explanation of various aspects of the invention. Rather the present invention should be understood to cover all aspects of the invention, including various modifications, equivalent processes, and alternative devices falling within the spirit and scope of the invention as defined by the appended claims and their equivalents.

10

What is claimed is:

1. A method of managing notes, comprising:
providing a plurality of notes from a first source and a second source, the first source and the
5 second source being produced from different devices, the first source being a visual representation of a
scene having one or more of the plurality of notes;
recognizing, by a processing unit, at least one of the plurality of notes from the first source;
extracting, by the processing unit, content of the one of the plurality of notes; and
labeling each of the plurality of notes provided by the first source and the second source with a
10 category.
2. The method of claim 1, wherein the labeling step comprises labeling the one of the plurality of
notes based on the extracted content.
- 15 3. The method of claim 1, wherein the one of the plurality of notes comprises a mark.
4. The method of claim 3, wherein the recognizing step comprises recognizing the mark of the one
of the plurality of notes from the visual representation.
- 20 5. The method of claim 4, wherein the recognizing step comprises determining the general boundary
of the one of the plurality of notes based upon the recognized mark, a known shape of the one of the
plurality of notes, and a known relative position of the mark on the one of the plurality of notes.
6. The method of claim 1, wherein the plurality of notes comprises physical notes, digital notes, and
25 a combination thereof.
7. The method of claim 1, further comprising:
presenting, by a presentation device, the extracted content to a user.
- 30 8. The method of claim 7, wherein the presenting step comprises presenting the extracted content
with an output field indicating the category of the one of the plurality of notes.
9. A note management system, comprising:
a first note source and a second note source configured to provide a plurality of notes, the first
35 note source and the second note source being produced from different devices, the first note source being
a visual representation of a scene having one or more notes,

a note recognition module configured to receive the visual representation and determine a general boundary of one of the plurality of notes from the visual representation,

a note extraction module configured to extract content of the one of the plurality of notes from the visual representation based on the determined general boundary of the one of the plurality of notes, and

5 a note labeling module configured to label the one of the plurality of notes with a category.

10. The note management system of claim 9, wherein the note labeling module is further configured to label the one of the plurality of notes based on the extracted content.

10 11. The note management system of claim 9, wherein the one of the plurality of notes comprises a mark, and wherein the note recognition module is further configured to recognize the mark of the one of the plurality of notes from the visual representation.

15 12. The note management system of claim 11, wherein the note recognition module is further configured to determine the general boundary of the one of the plurality of notes based upon the recognized mark.

13. The note management system of claim 9, further comprising:
a note presentation module configured to present the extracted content to a user.

20

14. The note management system of claim 9, further comprising:
a note authentication module configured to authenticate the one of the plurality of notes,
wherein the note extraction module is further configured to extract the content of the one of the plurality of notes if the one of the plurality of notes is authenticated.

25

15. The note management system of claim 9, wherein the note labeling module is further configured to label the one of the plurality of notes based on the extracted content and historical data.

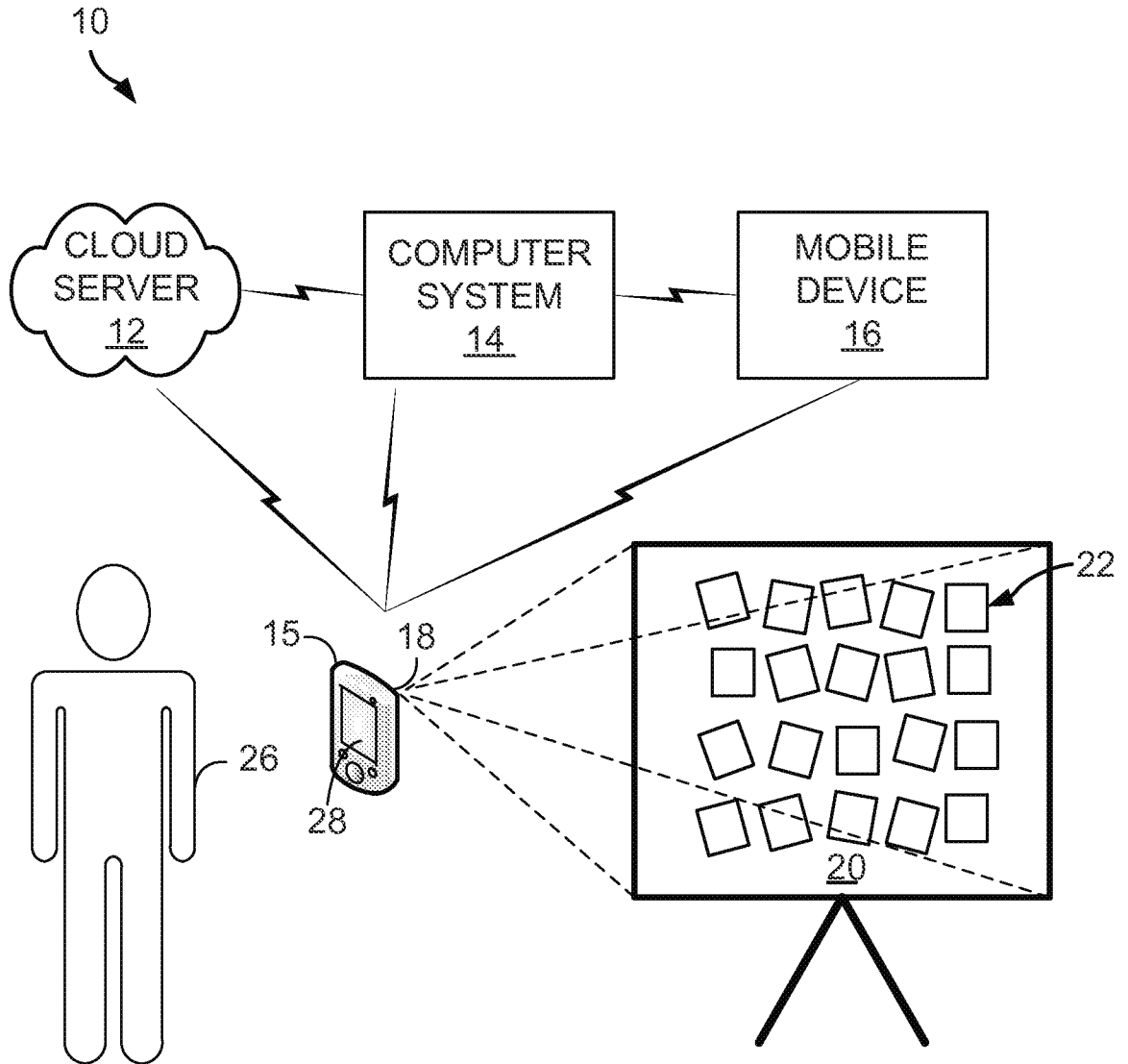

Fig. 1A

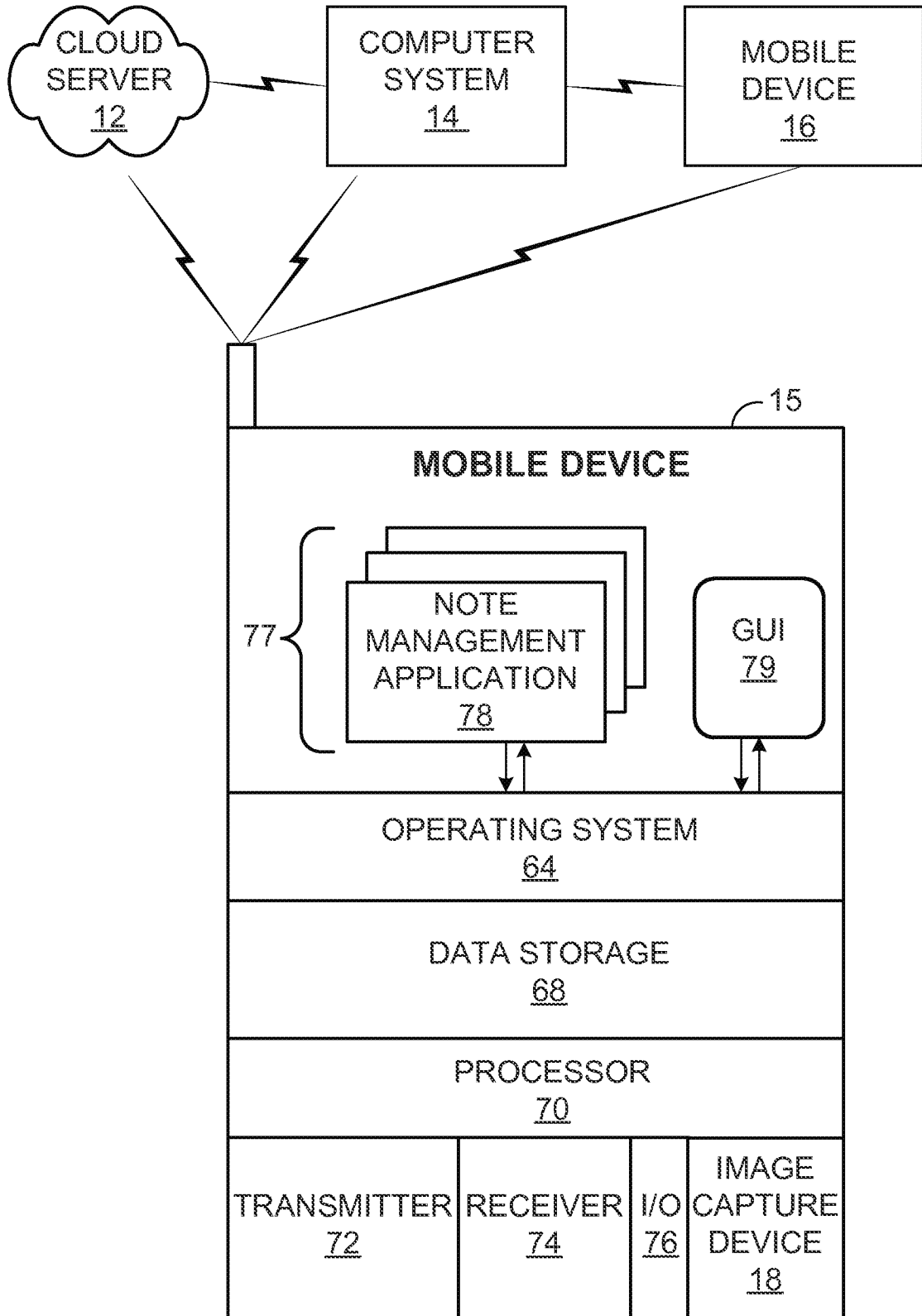

Fig. 1B

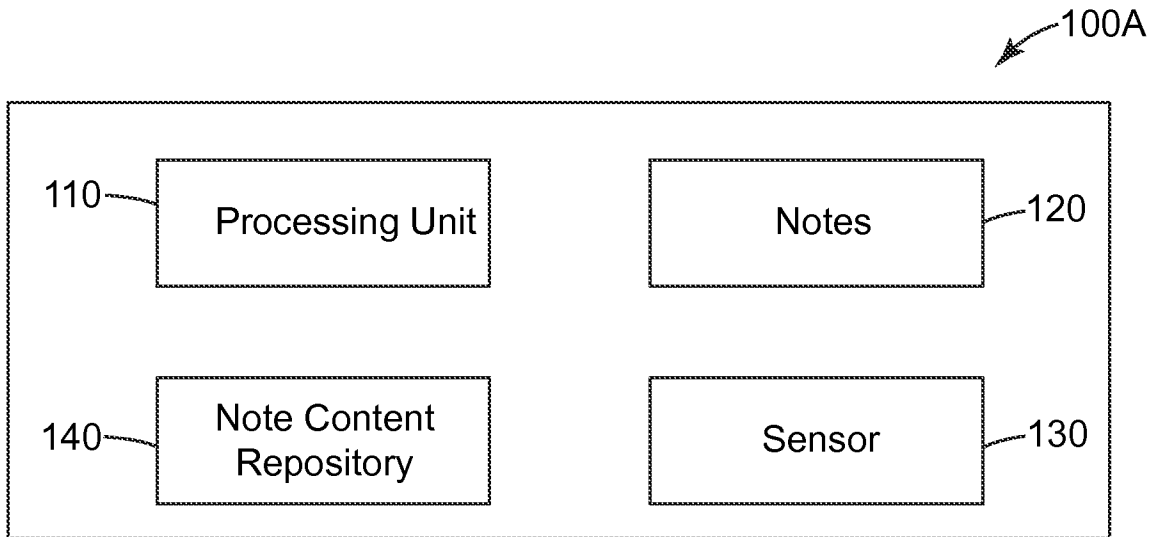

Fig. 1C

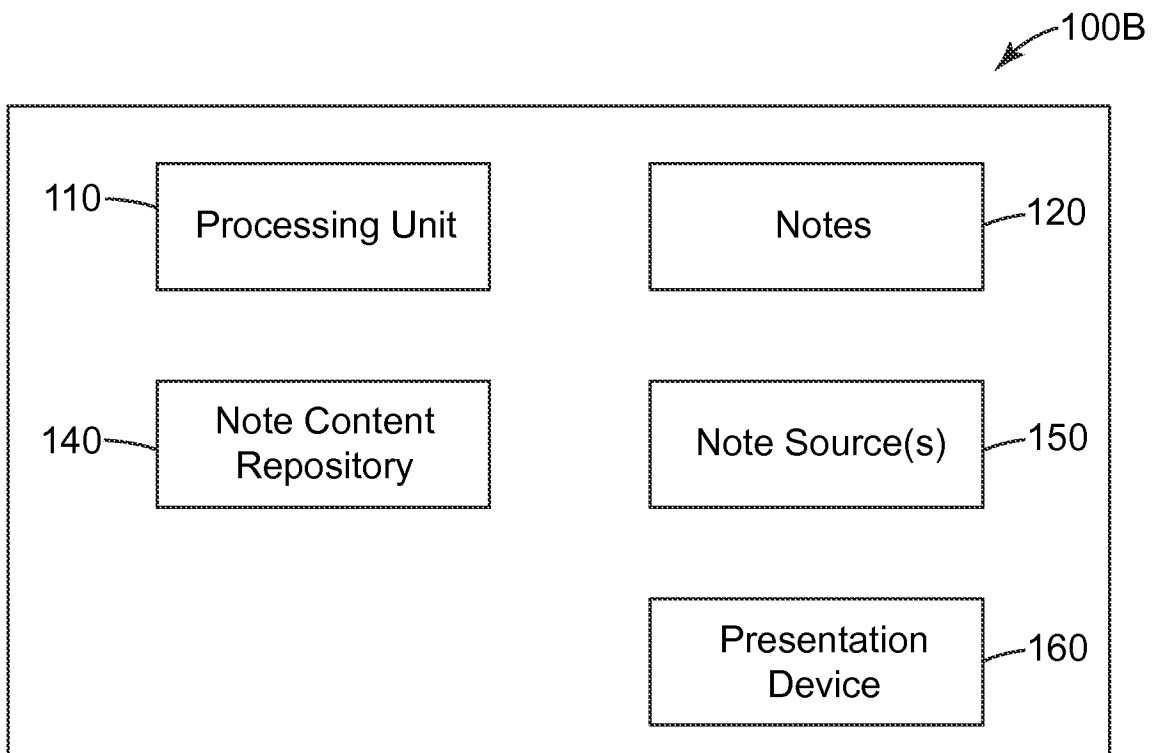

Fig. 1D

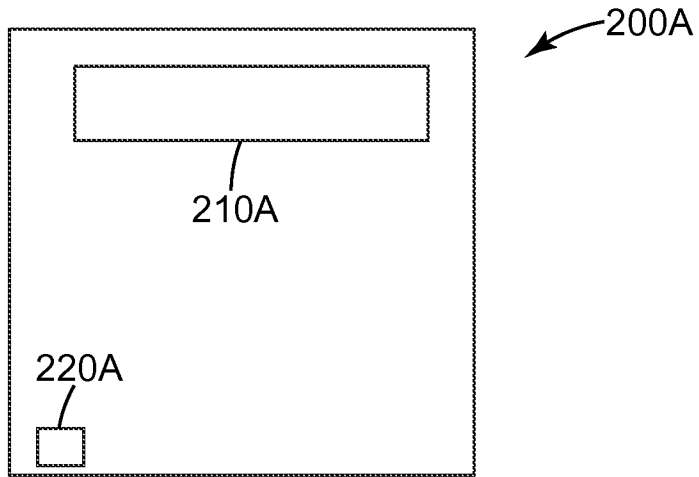

Fig. 2A

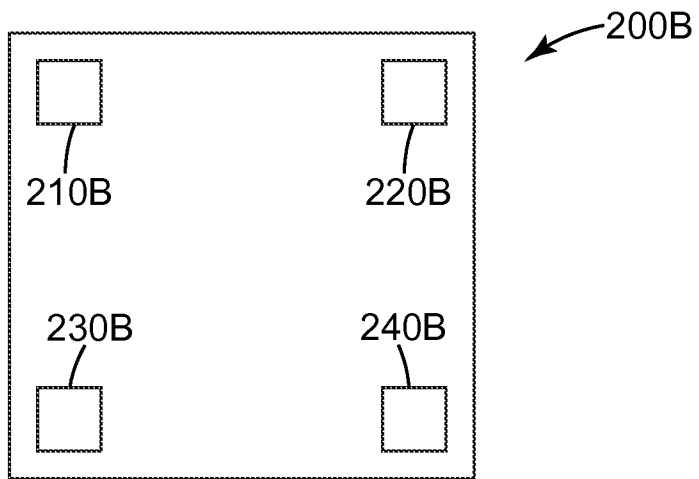

Fig. 2B

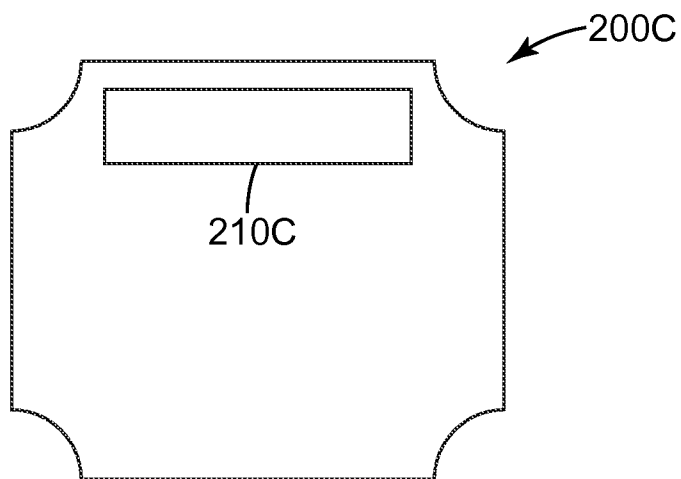

Fig. 2C

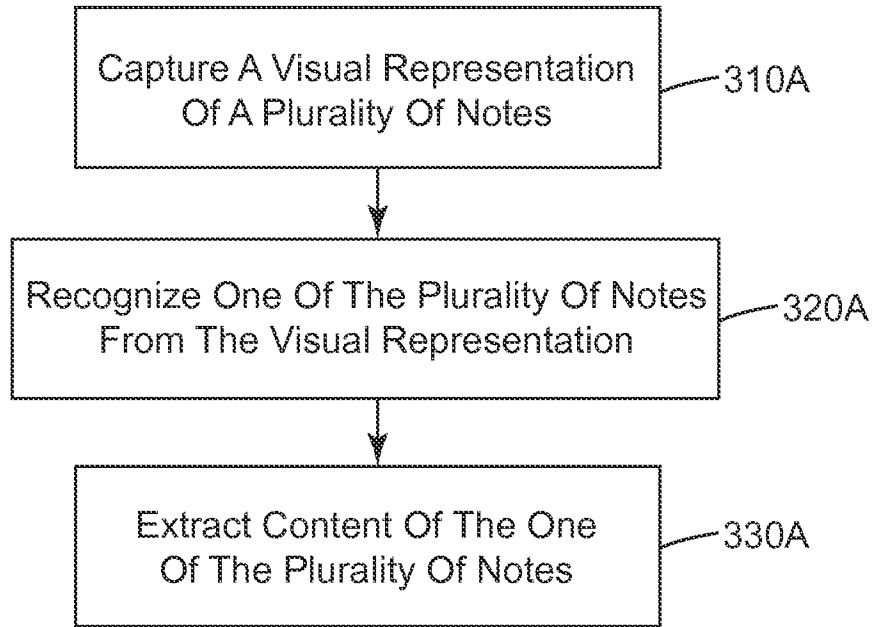

Fig. 3A

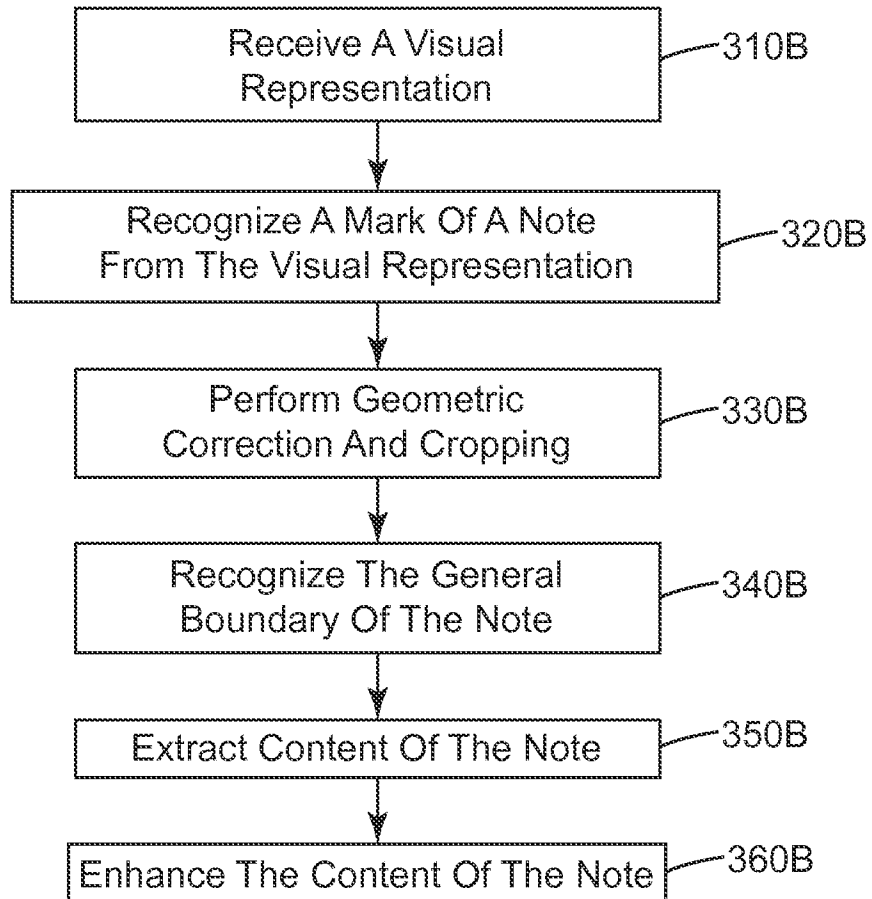

Fig. 3B

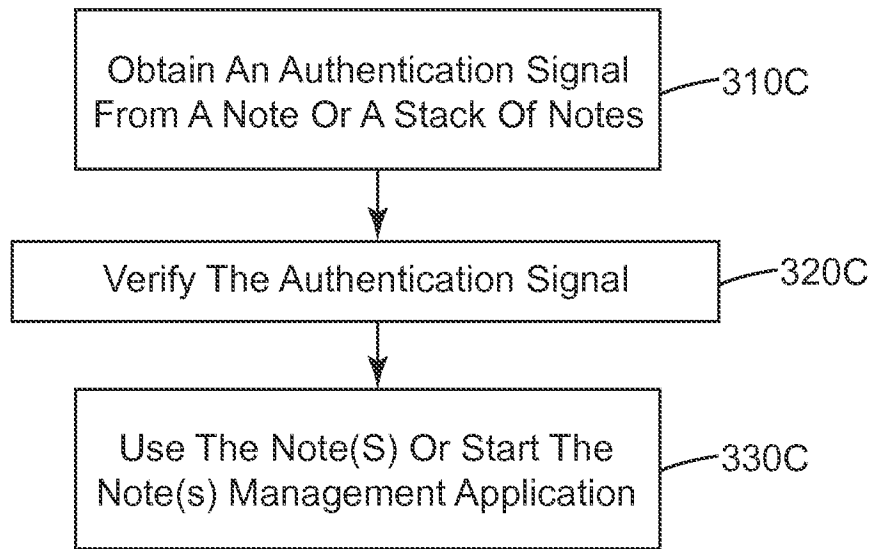

Fig. 3C

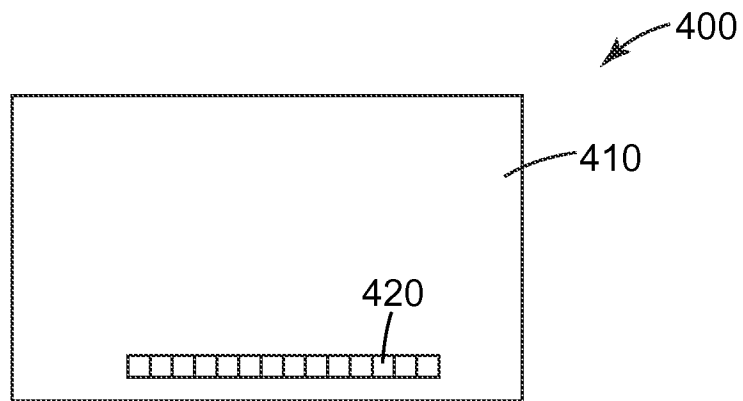

Fig. 4A

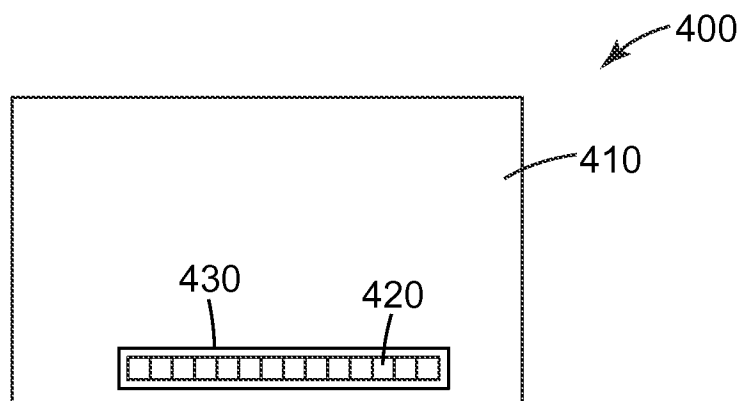

Fig. 4B

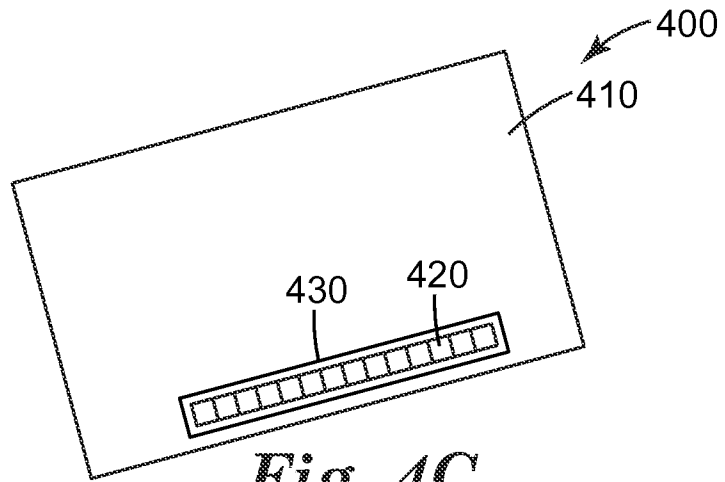

Fig. 4C

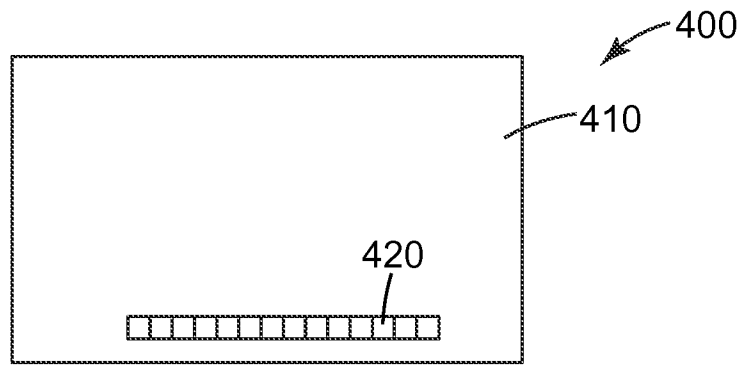

Fig. 4D

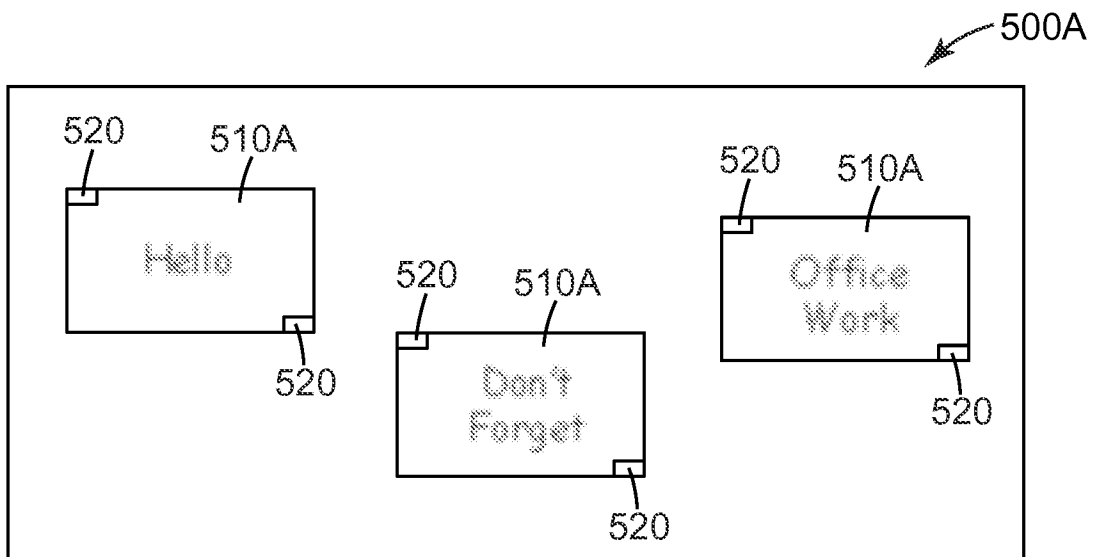

Fig. 5A

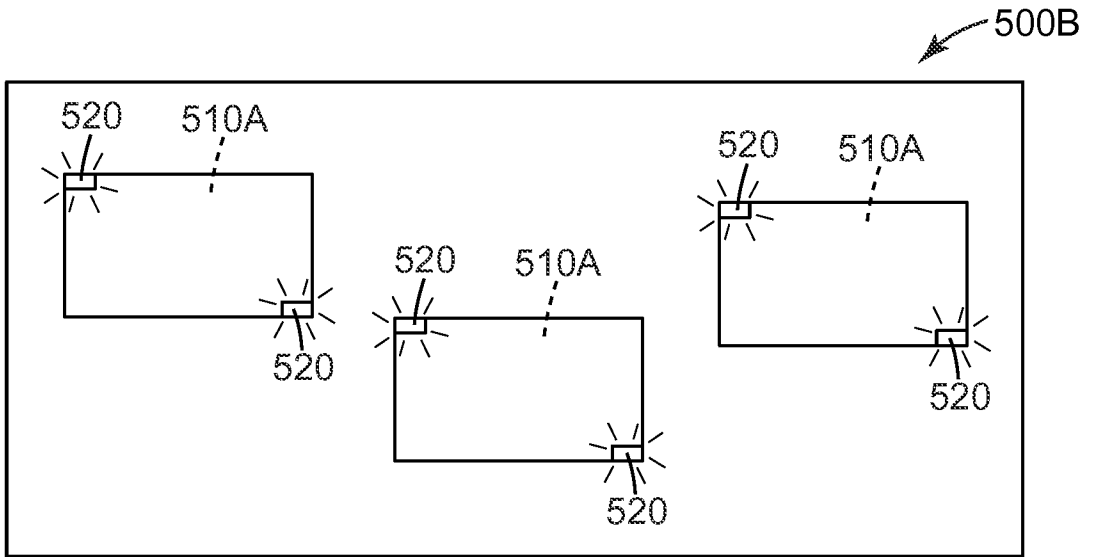

Fig. 5B

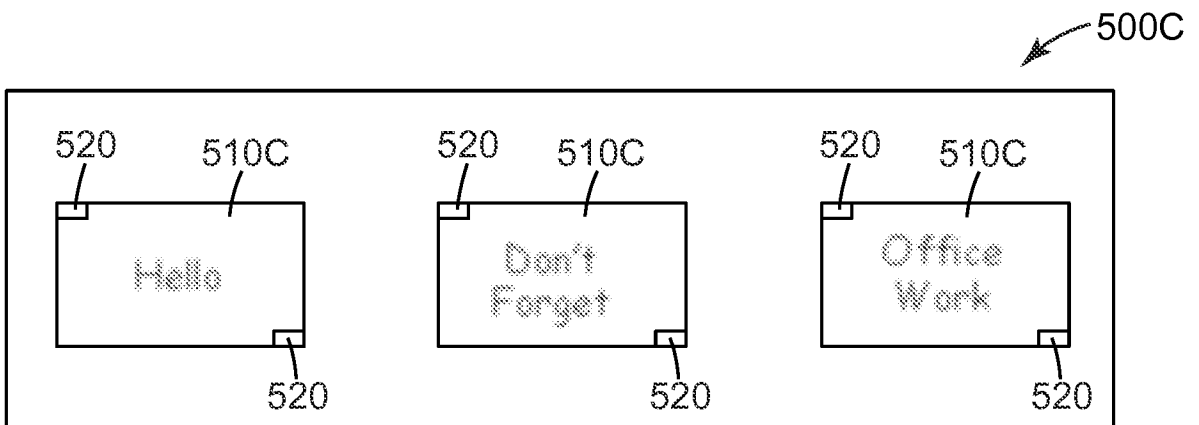

Fig. 5C

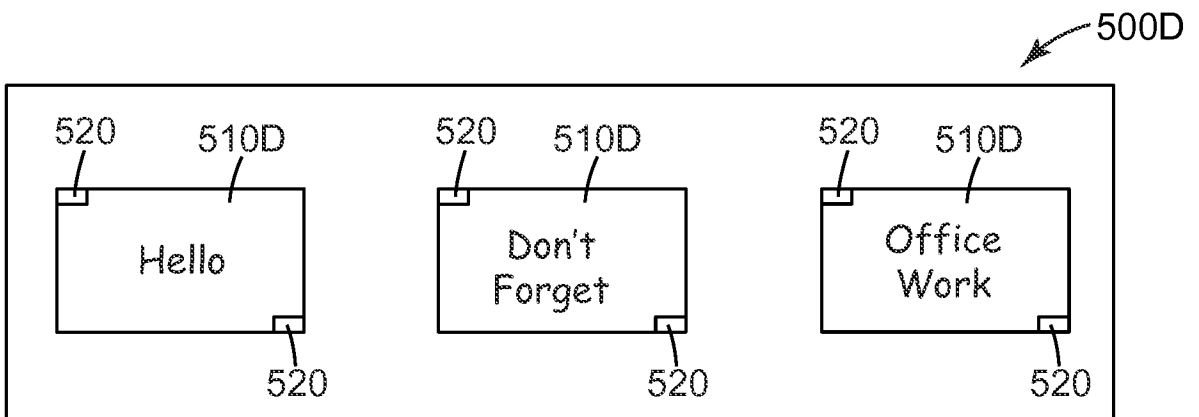

Fig. 5D

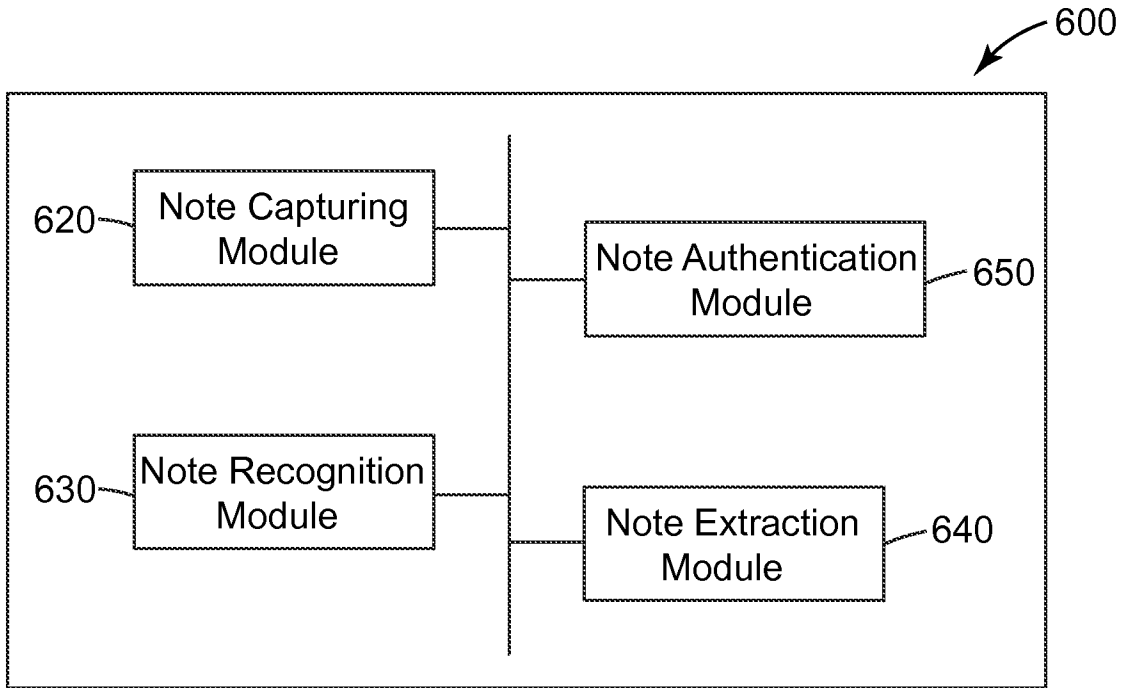

Fig. 6

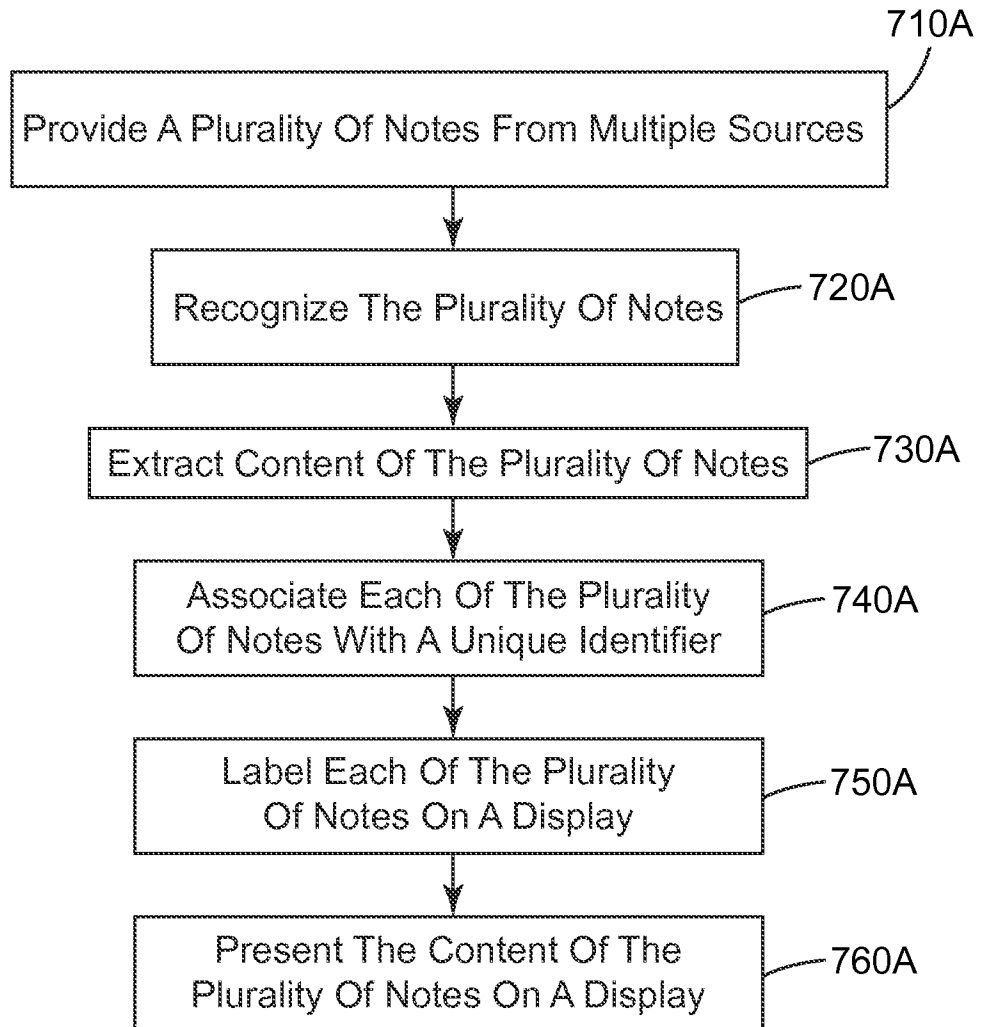

Fig. 7A

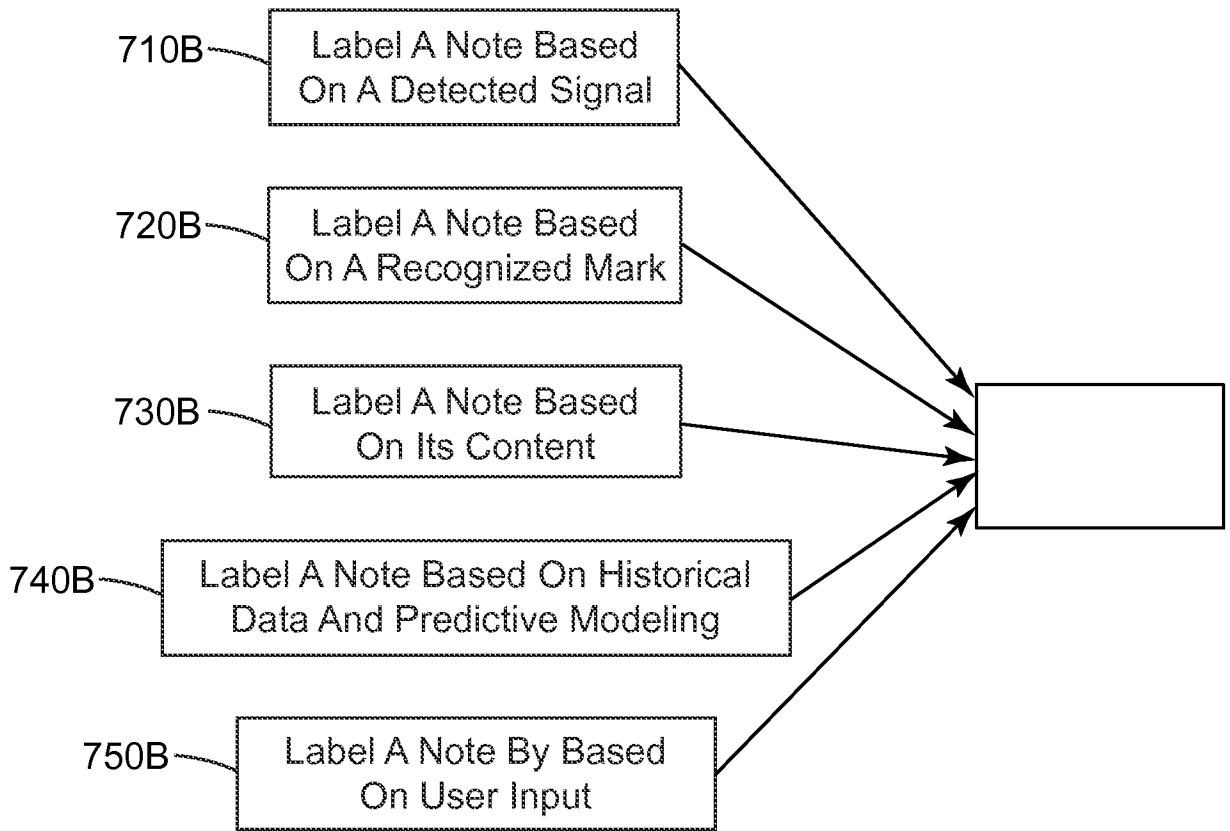

Fig. 7B

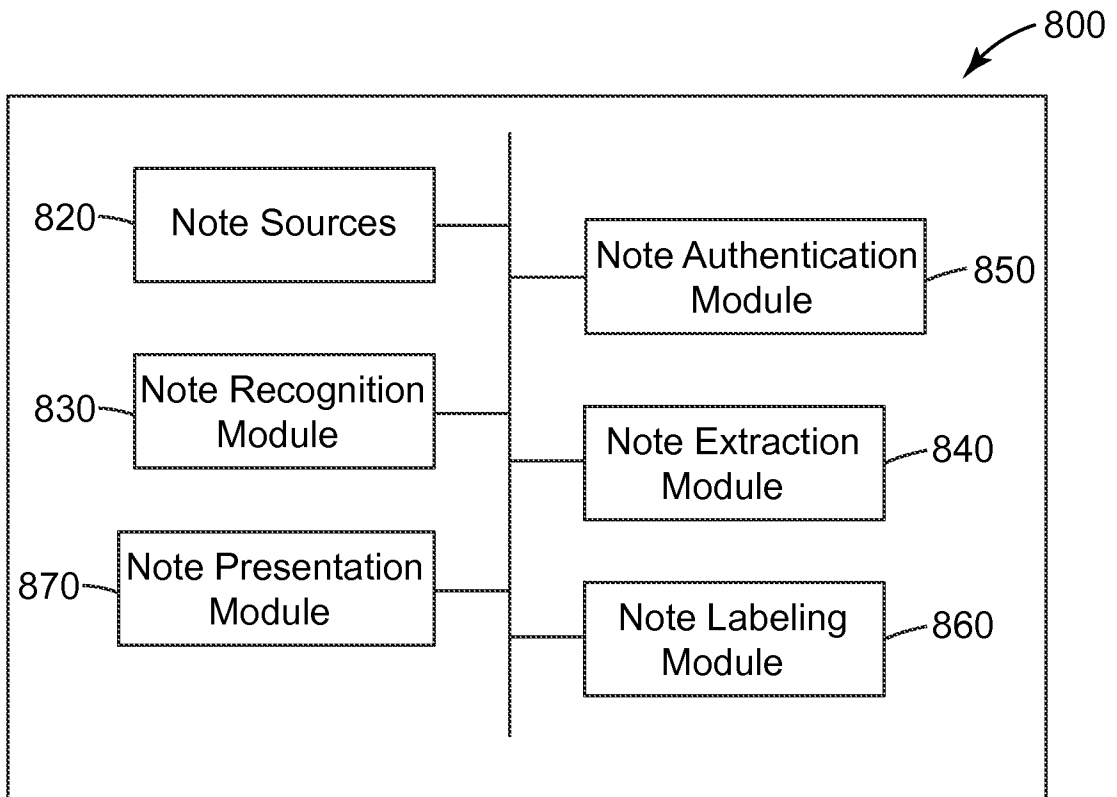

Fig. 8

INTERNATIONAL SEARCH REPORT

International application No.
PCT/US2014/032367

<p>A. CLASSIFICATION OF SUBJECT MATTER IPC(8) - G06K 9/00 (2014.01) USPC - 382/173 According to International Patent Classification (IPC) or to both national classification and IPC</p>																	
<p>B. FIELDS SEARCHED</p> <p>Minimum documentation searched (classification system followed by classification symbols) IPC(8) - G06K 9/00, 9/18, 9/22 (2014.01) USPC - 382/all, 165, 173, 176</p> <p>Documentation searched other than minimum documentation to the extent that such documents are included in the fields searched CPC - G06K 9/00, 9/18, 9/22 (2014.02)</p> <p>Electronic data base consulted during the international search (name of data base and, where practicable, search terms used) Orbit, Google Patents, Google Scholar,</p>																	
<p>C. DOCUMENTS CONSIDERED TO BE RELEVANT</p> <table border="1"> <thead> <tr> <th>Category*</th> <th>Citation of document, with indication, where appropriate, of the relevant passages</th> <th>Relevant to claim No.</th> </tr> </thead> <tbody> <tr> <td>X</td> <td>US 8,380,040 B2 (CARTER et al) 19 February 2013 (19.02.2013) entire document</td> <td>1-15</td> </tr> <tr> <td>A</td> <td>US 2012/0324372 A1 (KOWALKIEWICZ et al) 20 December 2012 (20.12.2012) entire document</td> <td>1-15</td> </tr> <tr> <td>A</td> <td>US 2004/0017400 A1 (LY et al) 29 January 2004 (29.01.2004) entire document</td> <td>1-15</td> </tr> <tr> <td>A</td> <td>US 2011/0285123 A1 (WITTKKE) 24 November 2011 (24.11.2011) entire document</td> <td>1-15</td> </tr> </tbody> </table>			Category*	Citation of document, with indication, where appropriate, of the relevant passages	Relevant to claim No.	X	US 8,380,040 B2 (CARTER et al) 19 February 2013 (19.02.2013) entire document	1-15	A	US 2012/0324372 A1 (KOWALKIEWICZ et al) 20 December 2012 (20.12.2012) entire document	1-15	A	US 2004/0017400 A1 (LY et al) 29 January 2004 (29.01.2004) entire document	1-15	A	US 2011/0285123 A1 (WITTKKE) 24 November 2011 (24.11.2011) entire document	1-15
Category*	Citation of document, with indication, where appropriate, of the relevant passages	Relevant to claim No.															
X	US 8,380,040 B2 (CARTER et al) 19 February 2013 (19.02.2013) entire document	1-15															
A	US 2012/0324372 A1 (KOWALKIEWICZ et al) 20 December 2012 (20.12.2012) entire document	1-15															
A	US 2004/0017400 A1 (LY et al) 29 January 2004 (29.01.2004) entire document	1-15															
A	US 2011/0285123 A1 (WITTKKE) 24 November 2011 (24.11.2011) entire document	1-15															
<p><input type="checkbox"/> Further documents are listed in the continuation of Box C. <input type="checkbox"/></p>																	
<p>* Special categories of cited documents:</p> <table border="0"> <tr> <td> <p>“A” document defining the general state of the art which is not considered to be of particular relevance</p> <p>“E” earlier application or patent but published on or after the international filing date</p> <p>“L” document which may throw doubts on priority claim(s) or which is cited to establish the publication date of another citation or other special reason (as specified)</p> <p>“O” document referring to an oral disclosure, use, exhibition or other means</p> <p>“P” document published prior to the international filing date but later than the priority date claimed</p> </td> <td> <p>“T” later document published after the international filing date or priority date and not in conflict with the application but cited to understand the principle or theory underlying the invention</p> <p>“X” document of particular relevance; the claimed invention cannot be considered novel or cannot be considered to involve an inventive step when the document is taken alone</p> <p>“Y” document of particular relevance; the claimed invention cannot be considered to involve an inventive step when the document is combined with one or more other such documents, such combination being obvious to a person skilled in the art</p> <p>“&” document member of the same patent family</p> </td> </tr> </table>			<p>“A” document defining the general state of the art which is not considered to be of particular relevance</p> <p>“E” earlier application or patent but published on or after the international filing date</p> <p>“L” document which may throw doubts on priority claim(s) or which is cited to establish the publication date of another citation or other special reason (as specified)</p> <p>“O” document referring to an oral disclosure, use, exhibition or other means</p> <p>“P” document published prior to the international filing date but later than the priority date claimed</p>	<p>“T” later document published after the international filing date or priority date and not in conflict with the application but cited to understand the principle or theory underlying the invention</p> <p>“X” document of particular relevance; the claimed invention cannot be considered novel or cannot be considered to involve an inventive step when the document is taken alone</p> <p>“Y” document of particular relevance; the claimed invention cannot be considered to involve an inventive step when the document is combined with one or more other such documents, such combination being obvious to a person skilled in the art</p> <p>“&” document member of the same patent family</p>													
<p>“A” document defining the general state of the art which is not considered to be of particular relevance</p> <p>“E” earlier application or patent but published on or after the international filing date</p> <p>“L” document which may throw doubts on priority claim(s) or which is cited to establish the publication date of another citation or other special reason (as specified)</p> <p>“O” document referring to an oral disclosure, use, exhibition or other means</p> <p>“P” document published prior to the international filing date but later than the priority date claimed</p>	<p>“T” later document published after the international filing date or priority date and not in conflict with the application but cited to understand the principle or theory underlying the invention</p> <p>“X” document of particular relevance; the claimed invention cannot be considered novel or cannot be considered to involve an inventive step when the document is taken alone</p> <p>“Y” document of particular relevance; the claimed invention cannot be considered to involve an inventive step when the document is combined with one or more other such documents, such combination being obvious to a person skilled in the art</p> <p>“&” document member of the same patent family</p>																
<p>Date of the actual completion of the international search 18 July 2014</p>		<p>Date of mailing of the international search report 12 AUG 2014</p>															
<p>Name and mailing address of the ISA/US Mail Stop PCT, Attn: ISA/US, Commissioner for Patents P.O. Box 1450, Alexandria, Virginia 22313-1450 Facsimile No. 571-273-3201</p>		<p>Authorized officer: Blaine R. Copenheaver PCT Helpdesk: 571-272-4300 PCT OSP: 571-272-7774</p>															