



(51) International Patent Classification:

G01N 27/416 (2006.01) C25C 3/16 (2006.01)
C25C 3/12 (2006.01) C25C 3/20 (2006.01)

(21) International Application Number:

PCT/CA2021/051512

(22) International Filing Date:

27 October 2021 (27.10.2021)

(25) Filing Language:

English

(26) Publication Language:

English

(30) Priority Data:

63/106,517 28 October 2020 (28.10.2020) US

(71) Applicant: **ELYSIS LIMITED PARTNERSHIP**
[CA/CA]; 1 Place Ville Marie, Suite #2323, Montréal,
Québec H3B 3M5 (CA).

(72) Inventors: **D'ASTOLFO, Leroy**; 233 Fairhaven Drive,
Lower Burrell, Pennsylvania 15068 (US). **FINDLEY,
Nicholas**; 200 Quaker Road, Sewickley, Pennsylvania
15143 (US).

(74) Agent: **CALVET, Damien** et al.; Gowling WLG (Canada)
LLP, 3700-1 Place Ville Marie, Montréal, Québec H3B 3P4
(CA).

(81) Designated States (unless otherwise indicated, for every
kind of national protection available): AE, AG, AL, AM,
AO, AT, AU, AZ, BA, BB, BG, BH, BN, BR, BW, BY, BZ,
CA, CH, CL, CN, CO, CR, CU, CZ, DE, DJ, DK, DM, DO,
DZ, EC, EE, EG, ES, FI, GB, GD, GE, GH, GM, GT, HN,
HR, HU, ID, IL, IN, IR, IS, IT, JO, JP, KE, KG, KH, KN,
KP, KR, KW, KZ, LA, LC, LK, LR, LS, LU, LY, MA, MD,
ME, MG, MK, MN, MW, MX, MY, MZ, NA, NG, NI, NO,
NZ, OM, PA, PE, PG, PH, PL, PT, QA, RO, RS, RU, RW,

(54) Title: DETECTING THERMITE REACTIONS IN AN ELECTROLYTIC CELL

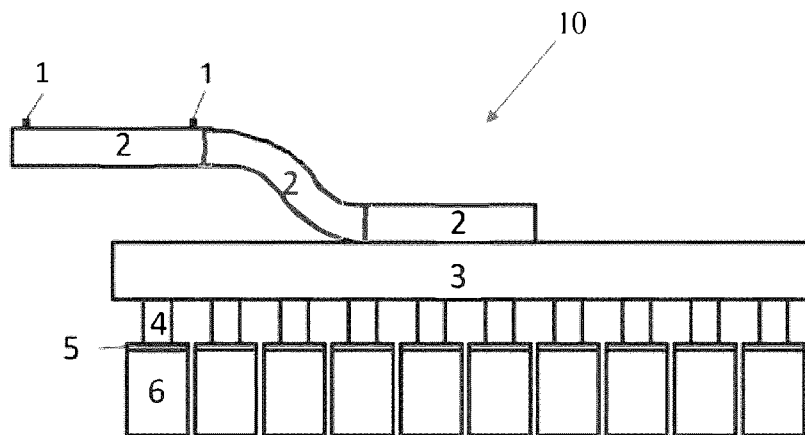

FIG. 1

(57) Abstract: A method for detecting a thermite reaction in an electrolytic cell comprising an anode assembly of one or more metal-oxide-containing anodes is disclosed. Each anode assembly is powered by a current provided through a distinct anode rod for each anode assembly. The method comprises: measuring a voltage drop using a pair of voltage probes located on the anode rod, the voltage drop corresponding to a current flow in the anode assembly; processing the voltage drop by computing at least one of the voltage drop derivative, the voltage drop variance, and the derivative of the voltage drop variance; and detecting a thermite reaction based on the results of the signal processing, before mitigating and/or suppressing the thermite reaction by adjusting the operational parameters of the electrolytic cell. This method is particularly advantageous as it reduces the number of voltage drops necessary for detecting a thermite reaction by a factor of 10.



SA, SC, SD, SE, SG, SK, SL, ST, SV, SY, TH, TJ, TM, TN,
TR, TT, TZ, UA, UG, US, UZ, VC, VN, WS, ZA, ZM, ZW.

- (84) Designated States** (*unless otherwise indicated, for every kind of regional protection available*): ARIPO (BW, GH, GM, KE, LR, LS, MW, MZ, NA, RW, SD, SL, ST, SZ, TZ, UG, ZM, ZW), Eurasian (AM, AZ, BY, KG, KZ, RU, TJ, TM), European (AL, AT, BE, BG, CH, CY, CZ, DE, DK, EE, ES, FI, FR, GB, GR, HR, HU, IE, IS, IT, LT, LU, LV, MC, MK, MT, NL, NO, PL, PT, RO, RS, SE, SI, SK, SM, TR), OAPI (BF, BJ, CF, CG, CI, CM, GA, GN, GQ, GW, KM, ML, MR, NE, SN, TD, TG).

Declarations under Rule 4.17:

- *as to applicant's entitlement to apply for and be granted a patent (Rule 4.17(ii))*

Published:

- *with international search report (Art. 21(3))*

DETECTING THERMITE REACTIONS IN AN ELECTROLYTIC CELL**Cross-Reference to Related Applications**

[0001] The present patent application claims the benefits of priority of U.S. Provisional Patent Application No. 63/106,517 entitled “SYSTEM AND METHOD FOR DETECTING THERMITE REACTIONS IN AN ELECTROLYTIC CELL”, and filed at the United States Patent and Trademark Office on October 28th, 2020, the content of which is incorporated herein by reference.

Technical Field

[0002] The present application generally relates to the detection and/or prevention of thermite reactions in electrolytic cells.

Background

[0003] Aluminum is the third most common element in the earth’s crust. The aluminum is extracted from aluminum oxide, also known as alumina, by an electrolysis process. The electrolysis process takes place inside an electrolytic cell comprising a plurality of cathodes, one or more anode assemblies, and an electrolytic bath containing molten cryolite in which the alumina is dissolved.

[0004] During the electrolysis process, aluminum ions flow towards the cathodes where they gain electrons and become aluminum metal. The oxide ions move towards the anodes where they lose electrons and pair up producing dioxygen molecules O₂. Hall-Héroult process implies the use of anodes made of carbon or graphite materials. The dioxygen molecules react with the carbon atoms of the carbon anodes producing carbon dioxide CO₂. This results in the anode being corroded and consumed during the electrolysis process. Besides, the use of carbon anodes have an environmental cost because of the CO₂ molecules that are released in the air.

[0005] “Inert anodes” have been used to replace the carbon graphite anodes during electrochemical reduction of metal oxides as they are insoluble in the electrolyte under the conditions of the electrolysis. The inert anodes are, thus, non-consumable during the electrolysis process. Moreover, the reaction taking place on the inert anodes does not produce CO₂ but rather O₂, making the use of inert anodes a greener technology. However, in the case of use of oxide-based inert anodes for electrochemical reduction of metals, such as aluminum, there is a possibility of a thermite reaction.

[0006] A thermite reaction is a reaction that involves a metal reacting with a metallic or a non-metallic oxide to form a more stable oxide and the corresponding metal or non-metal of the reactant oxide.

[0007] The thermite reaction that occurs during aluminum electrolysis is described
5 by the equation:

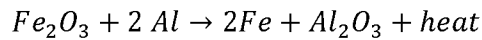

[0008] Thermite reactions are thus highly exothermic, self sustaining at high temperatures, and pose risks to personnel and equipment.

[0009] Detecting and mitigating and/or suppressing thermite reactions during the
10 electrolysis process implies monitoring the electrolytic cell. As disclosed in U.S. patent no. 9,982,355 B2 (D' Astolfo et al.), the content of which is incorporated herein by reference, monitoring the cell can be done by installing several probes on the conductive elements of the cell (for example, anodes) to measure the voltage drop of one or more anodes and to detect the thermite reaction. In this technique, the voltage probes may be
15 placed at a maximum distance apart to maximize the voltage drop relative to the noise and therefore to obtain a more sensitive response. This technique has the disadvantage of the high cost of installation and continuous monitoring of a large number of voltage drops necessary for the detection system.

[0010] There is thus a need for a more simple system and method for monitoring
20 electrolytic cell, detecting and mitigating and/or suppressing thermites reactions.

Summary

[0011] It is first disclosed herein a method for detecting a thermite reaction in an electrolytic cell comprising at least one anode assembly of one or more metal-oxide anodes, at least one cathode, an electrolytic bath, and a current supply buss providing a
25 current to the at least one anode assembly through a distinct anode rod for each anode assembly. The method comprises: measuring a voltage drop using a pair of voltage probes located on the anode rod of each anode assembly, the voltage drop corresponding to a current flow in each anode assembly; computing from said measured voltage drop at least one of: a voltage drop derivative, a voltage drop variance across
30 the one or more anode assemblies; and a derivative of the voltage drop variance across the one or more anode assemblies, wherein said voltage drop variance and derivative of the voltage drop variance may be computed when the electrolytic cell comprises a

3

plurality of anode assemblies. The method also comprises: detecting the thermite reaction upon occurrence of one or more of: a voltage drop exceeding at least one voltage threshold level, wherein each voltage threshold level is a predetermined voltage drop previously associated with a thermite reaction; a variation in the voltage drop derivative; a variation in the variance of the voltage drop across the anode assemblies; and a variation in the derivative of the voltage drop variance across the anode assemblies. The method may further comprise, upon detection of the thermite reaction, optionally adjusting at least one operational parameter of the electrolytic cell to mitigate and/or suppress the thermite reaction.

10 **[0012]** According to a preferred embodiment, the method further comprises sending a signal to an operator of the electrolytic cell upon detection of the thermite reaction.

[0013] According to a preferred embodiment, the threshold voltage levels are based on past operational data of the electrolytic cell.

15 **[0014]** According to a preferred embodiment, the threshold voltage levels are computer derived threshold levels derived from at least one of past operational data of the electrolytic cell, operation parameters, and composition of the electrolytic cell.

[0015] According to a preferred embodiment, the thermite reaction is detected when the variation in voltage drop derivative exceeds a threshold variation.

20 **[0016]** According to a preferred embodiment, the thermite reaction is detected when the variation in variance of the voltage drop across the anode assemblies exceeds a threshold variation.

[0017] According to a preferred embodiment, the thermite reaction is detected when the variation in derivative of the voltage drop variance across the anode assemblies exceeds a threshold variation.

25 **[0018]** According to a preferred embodiment, adjusting at least one operational parameter of the electrolytic cell to mitigate and/or suppress the thermite reaction comprises one or more of:

changing an anode to cathode overlap (ACO) of one or more anode assemblies;
30 removing one or more anode assemblies from the electrolytic bath;
changing the current supplied to at least one of the one or more anode assemblies

or the electrolytic cell;

changing a temperature of the electrolytic bath; and

changing a chemistry of the electrolytic bath.

5 [0019] According to a preferred embodiment, when the voltage drop of one of the anode assemblies exceeds the at least one voltage threshold level, adjusting at least one operational parameter of the electrolytic cell takes into account one or more of the exceeded voltage threshold levels.

[0020] According to a preferred embodiment, upon detection of the thermite reaction, adjusting at least one operational parameter of the electrolytic cell takes into
10 account a magnitude of the voltage drop.

[0021] According to a preferred embodiment, upon detection of the thermite reaction, adjusting at least one operational parameter of the electrolytic cell takes into account a magnitude of the voltage drop derivative.

[0022] According to a preferred embodiment, upon detection of the thermite
15 reaction, adjusting at least one operational parameter of the electrolytic cell takes into account a magnitude of the variance of the voltage drop.

[0023] According to a preferred embodiment, upon detection of the thermite reaction, adjusting at least one operational parameter of the electrolytic cell takes into account a magnitude of the derivative of the voltage drop variance.

20 [0024] According to a preferred embodiment, the method further comprises filtering the voltage drop, the voltage drop derivative, the variance of the voltage drop, and/or the derivative of the voltage drop variance.

[0025] It is also disclosed herein a system for detecting a thermite reaction in an electrolytic cell comprising at least one anode assembly of one or more metal-oxide-
25 containing anodes, at least one cathode, an electrolytic bath, and a current supply buss providing a current to the at least one anode assembly through a distinct anode rod for each anode assembly. The system comprises:

a pair of voltage probes located on the anode rod of each anode assembly for
30 measuring a voltage drop, the voltage drop corresponding to a current flow in the anode assembly;

5

a processor module for:

computing from said measured voltage drop at least one of:

a voltage drop derivative;

a voltage drop variance across the one or more anode assemblies;

5 and

a derivative of the voltage drop variance across the one or more anode assemblies;

wherein said voltage drop variance and derivative of the voltage drop variance are computed when the electrolytic cell comprises a plurality of anode assemblies; and

10

detecting the thermite reaction upon occurrence of one or more of:

a voltage drop exceeding at least one voltage threshold level, wherein each voltage threshold level is a predetermined voltage drop previously associated with a thermite reaction;

15

a variation in voltage drop derivative;

a variation in variance of the voltage drop across the anode assemblies; and

a variation in derivative of the voltage drop variance across the anode assemblies.

20 **[0026]** According to a preferred embodiment, the system further comprises a communication module for sending a signal to an operator of the electrolytic cell upon detection of the thermite reaction.

[0027] According to a preferred embodiment, the threshold voltage levels are based on past operational data of the electrolytic cell.

25 **[0028]** According to a preferred embodiment, the threshold voltage levels are computer derived threshold levels derived from at least one of past operational data of the electrolytic cell, operation parameters, and composition of the electrolytic cell.

[0029] According to a preferred embodiment, the processor module is configured to detect the thermite reaction when the variation in voltage drop derivative exceeds a

threshold variation.

[0030] According to a preferred embodiment, the processor module is configured to detect the thermite reaction when the variation in variance of the voltage drop across the anode assemblies exceeds a threshold variation.

5 **[0031]** According to a preferred embodiment, the processor module is configured to detect the thermite reaction when the variation in derivative of the voltage drop across the anode assemblies exceeds a threshold variation.

[0032] According to a preferred embodiment, the processor module is configured to adjust at least one operational parameter of the electrolytic cell to mitigate and/or
10 suppress the thermite reaction by:

changing an anode to cathode overlap (ACO) of one or more anode assemblies;

removing one or more anode assemblies from the electrolytic bath;

changing the current supplied to at least one of the one or more anode assemblies or the electrolytic cell;

15 changing a temperature of the electrolytic bath; and/or

changing a chemistry of the electrolytic bath.

[0033] According to a preferred embodiment, when the voltage drop of one of the anode assemblies exceeds the at least one voltage threshold level, the processor module is configured to adjust at least one operational parameter of the electrolytic cell by
20 taking into account one or more of the exceeded voltage threshold levels.

[0034] According to a preferred embodiment, upon detection of the thermite reaction, the processor module is configured to adjust at least one operational parameter of the electrolytic cell taking into account a magnitude of the voltage drop.

[0035] According to a preferred embodiment, upon detection of the thermite
25 reaction, the processor module is configured to adjust at least one operational parameter of the electrolytic cell taking into account a magnitude of the voltage drop derivative.

[0036] According to a preferred embodiment, upon detection of the thermite reaction, the processor module is configured to adjust at least one operational parameter of the electrolytic cell taking into account a magnitude of the variance of the voltage
30 drop.

[0037] According to a preferred embodiment, upon detection of the thermite reaction, the processor module is configured to adjust at least one operational parameter of the electrolytic cell taking into account a magnitude of the derivative of the voltage drop variance.

5 [0038] According to a preferred embodiment, the processor module is further configured to filter the voltage drop, the voltage drop derivative, the variance of the voltage drop, and/or the derivative of the voltage drop variance.

[0039] Another aspect is directed to an electrolytic cell comprising at least one anode assembly of one or more metal-oxide-containing anodes, at least one cathode, an electrolytic bath, and a current supply buss providing a current to the at least one anode assembly through a distinct anode rod for each anode assembly, and the system for
10 detecting a thermite reaction as defined herein. Preferably, the electrolytic cell is used for the making of a metal, such as, but not limited to, aluminum (Al).

[0040] The method, system and electrolytic cell as disclosed herein are particularly
15 advantageous as they allow reducing the number of voltage signals/ drops necessary for detecting a thermite reaction by a factor of 10. Other advantages are detailed herein.

Brief Description of the Drawings

[0041] The above and other aspects, features and advantages will become more readily apparent from the following description, reference being made to the
20 accompanying drawings in which:

[0042] Figure 1 is a schematic illustration of an anode assembly for an electrolytic cell with a horizontal configuration of the anode rod, according to a preferred embodiment;

[0043] Figure 2 is a schematic illustration of an anode assembly for an electrolytic
25 cell with a vertical configuration of the anode rod, according to a preferred embodiment;

[0044] Figure 3 shows a graphic of voltage drops for a cell according to a preferred embodiment, in which the cell comprises four anode assemblies in which one of the assemblies is experiencing a simulated thermite reaction;

[0045] Figure 4 shows a graphic of voltage drop derivatives for a cell according to
30 a preferred embodiment, in which the cell comprises four anode assemblies in which one of the assemblies was experiencing a simulated thermite reaction;

[0046] Figure 5 shows a graphic of variance of the voltage drop for a cell according to a preferred embodiment in which the cell comprises four anode assemblies in which one of the assemblies was experiencing a simulated thermite reaction;

5 [0047] Figure 6 shows a graphic of the derivative of the voltage drop variance for a cell according to a preferred embodiment in which the cell comprises four anode assemblies in which one of the assemblies was experiencing a simulated thermite reaction;

[0048] Figure 7 is a flow chart for illustrating a method for detecting a thermite reaction in an electrolytic cell, according to a preferred embodiment; and

10 [0049] Figure 8 shows a logical modular representation of a system for detecting a thermite reaction in an electrolytic cell in accordance with the teachings of the present invention.

Detailed Description of Preferred Embodiments

[0050] A novel **system, method and related electrolytic cell** will be described hereinafter. Although they are described in terms of specific illustrative embodiments, it is to be understood that the embodiments described herein are by way of example only and that the scope of the invention is not intended to be limited thereby.

[0051] The terminology used herein is in accordance with definitions set out below.

20 [0052] The description which follows, and the embodiments described therein are provided by way of illustration of an example of particular embodiments of principles and aspects of the present invention. These examples are provided for the purposes of explanation and not of limitation of the principles of the invention. In the description that follows, like parts and/or steps are marked throughout the specification and the drawing with the same respective reference numerals.

[0053] As aforesaid, disclosed herein is a detection system and method for detecting a thermite reaction in an electrolytic cell. The electrolytic cell typically comprises at least one cathode assembly having at least one cathode, such as, but not limited to vertical cathodes, and configured for receiving or interacting with at least one
30 corresponding anode assembly having at least one anode, such as, but not limited to vertical anodes. The electrolysis cell is also configured to receive an electrolytic bath

of a molten electrolyte (such as cryolite) for the electrolytic production of metals, such as aluminum.

[0054] The “cathode” is an electrode negatively charged and the “anode” is a positively charged electrode. Anodes used in electrolytic processes can be consumable (e.g. carbon and graphite anodes used with the Hall-Heroult process) or alternatively
5 (e.g. carbon and graphite anodes used with the Hall-Heroult process) or alternatively non-consumable anodes, such as inert or oxygen evolving anodes. “Inert anodes” are not oxidized during the electrolysis process and are thus insoluble in the electrolytic bath during the electrolysis process. Inert anodes can be made of single compounds, composite, or alloy-type materials. Examples of inert anodes include: ceramic, cermet,
10 metal anodes, and any combination thereof. The inert anodes may be constructed of electrically conductive materials such as metal oxides. By “metal-oxide-containing anodes” used herein, it is meant an anode comprising at least a portion of metal oxides.

[0055] Figures 1 and 2 are schematic illustrations of an anode assembly in accordance with preferred embodiments. Figure 1 shows a horizontal configuration of the anode rod of the anode assembly whereas Figure 2 shows a vertical configuration
15 of the anode rod.

[0056] More specifically, the anode assembly **10** of Figures 1 and 2 comprises an anode rod **2** for feeding the electrical current to a supporting yoke or beam **3**. The electrical current flowing through the anode rod **2** is provided via a current supply buss
20 (not shown) that feeds the electrical current to all the anode assemblies of an electrolytic cell. The electrical current is then distributed through stubs **4** and distribution plates **5** to a plurality of anodes **6**. The anode assembly further comprises a pair of voltage probes **1** used to measure a voltage drop in the anode assembly.

[0057] As explained above, thermite reactions may occur when oxide-based inert
25 anodes are used for electrochemical reduction of metals, such as aluminum. Thermite reactions need to be rapidly detected and stopped as they pose risks to personnel and equipment.

[0058] Thermite reactions can be caused by direct contact between the anodes and a molten metal source, such as a metal pad. Thermite reactions may be initiated by an
30 electrical short where more current flows through the path of the electrical short. An electrical short may be detected as a voltage drop increase between one or more voltage probes. With reference to the present disclosure, the voltage drop can be used to detect

a potential thermite reaction and initiate appropriate responses, such as moving the anodes away from the metal pad, and/or reducing current supply.

[0059] By “voltage drop”, it is meant a voltage difference between two objects or two points of the same object.

5 [0060] A “voltage probe” measures the voltage drop and outputs an electrical signal representative of the measured voltage drop.

[0061] A system is described herein comprising one voltage probe, for each anode assembly, in an electrochemical reduction cell that can detect and help prevent thermite reactions from occurring between a metal-oxide-containing anode and a liquid metal,
10 such as aluminum. Reduction in total number of signals required to detect a potential thermite condition compared to prior solution is targeted herein. Such a reduction may be achieved by probe placement to maximize signal-to-noise ratio, and the consideration of time-dependent derivative signals and signal variance to enhance the interpretation of the signals.

15 [0062] In a preferred embodiment, a pair of voltage probes is used to measure the voltage drop in each anode assembly.

[0063] An ideal voltage probe preferably provides: connection ease and convenience, absolute signal fidelity, zero signal source loading, and complete noise immunity. Real voltage probes may raise several problems such as: physical attachment
20 of the probe on the circuit, impact of the probe on the circuit operation, and signal fidelity. Real voltage probes, inherently, induce background noise in the measurement data. Background noise may be caused by different factors such as: measurement errors, movement of the circuit, imperfection of the measurement devices, etc.

[0064] Measuring the “signal-to-noise ratio” (SNR) allows comparing the level of
25 a desired signal (e.g., a voltage drop) to the level of background noise.

[0065] In a preferred embodiment, the pair of voltage probes is located on the anode rod. The location of the voltage probes is optimized to maximize the signal-to-noise ratio (SNR). The two voltage probes are placed as far apart as possible so that they detect larger voltage drop signals. As the noise is assumed to be constant through
30 the anode assembly, the signal-to-noise ratio (SNR) is thus maximized.

[0066] By reducing the number of voltage probes to be installed in order to detect

a thermite reaction, reducing the number of signals to be monitored is made possible. The current method allows reducing the number of voltage signals or drops by a factor of ten compared to other solutions, such as, for instance in U.S. patent 9,982,355 B2 (D'Astolfo et al.), the content of which is incorporated herein by reference. Therefore, reducing costs related to thermite reaction detection becomes achievable.

[0067] The electrical current passing through an anode I_{anode} can be determined knowing the voltage drop V , the material resistivity ρ , the length L , and the area A , by the equation:

$$I_{anode} = \frac{V * A}{\rho * L}$$

[0068] The electrical current required to initiate a thermite reaction on the anode can be known by experimentation. When the exact location of a potential electrical short is not known, a conservative assumption can be made that any rise in electrical current for an anode assembly is concentrated on only one anode. Then, one or more voltage threshold levels can be calculated based on a current threshold level for a single anode in the anode assembly.

[0069] By "voltage threshold level", it is meant a predetermined voltage drop previously associated with a thermite reaction.

[0070] In the case where a pair of voltage probes is used to measure the voltage drop in an anode assembly, the voltage threshold levels V_{T_i} for thermite reactions may be calculated using the equation:

$$V_{T_i} = \frac{1}{K_i} \left[\left(\frac{I}{\sum N} \right) (n_i - 1) + T_i \right]$$

wherein: V_{T_i} is the voltage drop for level i threshold, T_i is the threshold current per anode for level i threshold, N represents the number of anodes in the cell, n_i is the number of anodes per voltage probe, I is the total cell current, and $K_i = I/V$ is a proportionality constant of the voltage probe.

[0071] The different levels i may be determined experimentally based on threshold current levels per anode that are known to cause a thermite reaction or damage to the anode.

[0072] The proportionality constant of the voltage probe K_i may be calculated as a function of the material resistivity, temperature and the geometry of the voltage probe.

[0073] When no thermite reaction is taking place in the electrolytic cell, the “baseline voltage” measures the voltage drop per voltage probe.

5 [0074] In the example where a pair of voltage probes is used to measure the voltage drop in an anode assembly, the baseline voltage V_b may be given by:

$$V_b = \frac{1}{K_i} \left[\left(\frac{I}{\sum N} \right) n_i \right]$$

[0075] Therefore, the ratio of the voltage threshold level to baseline voltage is given by:

10
$$\frac{V_{T_i}}{V_b} = 1 - \frac{1}{n_i} + \frac{T_i}{(I/N)n_i}$$

[0076] For a commercial electrolysis cell, the preceding equation can be approximated by the following equation:

$$\frac{V_{T_i}}{V_b} = 1 + \frac{1.5}{n_i}$$

[0077] For a first level threshold voltage V_{T_1} , the number of anodes per voltage probe n_i can be as many as 100. Therefore, the threshold to base voltage ratio $\frac{V_{T_1}}{V_b}$, can be as small as 1.015. Thus, the detection system should be capable of detecting a 1.5% increase in the voltage drop.

[0078] One approach to increase the sensitivity of the detection system is by choosing a location of the voltage probes that optimizes the signal-to-noise ratio (SNR). As explained above, the voltage probes are placed as far apart as possible so that they detect larger voltage drop signals. As the noise is assumed to be constant through the anode assembly, the signal-to-noise ratio (SNR) is thus maximized.

[0079] Figure 3 shows a graphic of voltage drops for a cell comprising four anode assemblies in which one of the anode assemblies is experiencing a simulated thermite reaction. In this instance, anode assemblies 1 and 2 were sequentially shorted (first assembly 1 then 2).

25

[0080] From Figure 3, it can be seen that when a thermite reaction is simulated, the voltage drop increases on the shorted assembly (first assembly 1 then assembly 2). A clear voltage drop is observed on the shorted assembly, while the other assemblies showed a reduction in the voltage drop, as less electrical current flowed to them.

5 [0081] As shown in Figure 3, the voltage drop of each anode assembly is independent of the voltage drops of the other anode assemblies allowing to identify the location of the anode assembly experiencing the thermite reaction. Thus, a targeted response can be considered in order to mitigate and, ideally, suppress the thermite reaction.

10 [0082] It can be noticed from Figure 3 that each anode assembly may experience a different baseline voltage.

[0083] The voltage drop has the characteristics of: having a variable baseline voltage, depending on position of anodes and their number, and depending on the overlapping dimensions of the anode and cathode (ACO). Indeed, the ACO affects the intensity of the electrical current flowing through the anode assembly. Therefore, a variation of the ACO affects the voltage drop experienced by the anode assembly. The voltage drop may also vary depending on the anode to cathode distance (ACD).

15 [0084] A thermite condition typically arises suddenly, which allows for the consideration of a number of potential signal processing techniques to enhance detectability of thermite reactions besides the direct voltage reading from the voltage probe. One technique is to use the time derivative of the voltage drop to indicate occurrence of a potential thermite reaction. A sudden voltage drop variation would produce a large spike in the derivative signal (i.e., voltage drop derivative) thereby allowing to detect a potential thermite reaction.

25 [0085] Figure 4 shows a graphic of the voltage drop derivatives computed from the voltage drops of Figure 3. From Figure 4, it can be seen that a distinct voltage drop derivative initially positive, then negative is obtained for each simulated thermite reaction. The positive voltage drop derivative corresponds to the initial rise of the electrical current flowing through the shorted anode assembly. Adversely, the negative voltage drop derivative corresponds to the fall of the electrical current at the end of the simulated thermite reaction.

30 [0086] As shown in Figure 4, the voltage drop derivative of each anode assembly

is independent of the voltage drop derivative of the other anode assemblies allowing to identify the location of the thermite reaction (i.e., which anode assembly is experiencing a thermite reaction). Thus, a targeted response can be considered in order to mitigate and, ideally, suppress the thermite reaction.

5 [0087] The voltage drop derivative takes into account the variation of the voltage drop rather than its magnitude. Therefore, the voltage drop derivative has a zero baseline voltage and is more sensitive to sudden changes in the voltage drop.

[0088] One disadvantage of the voltage drop derivative is that it may not provide a clear information as to the end of the thermite reaction.

10 [0089] Another technique would be to use the variance of multiple voltage drops at each time. "Variance" of a system measures how far a set of values are spread out from their average value.

[0090] Since a commercial electrolysis cell contains multiple anodes or anode assemblies, a comparison of the voltage drops from each of these assemblies can be performed. Generally, if an anode assembly is experiencing an electrical short, more current will flow to this assembly and less to the other anode assemblies. Therefore, the magnitude of the variance will change for the whole cell. This condition is a tell-tale condition for an isolated electrical short. In cases where the voltage drops across the anode assemblies are in a narrow range, a sudden change in the voltage drop of an anode assembly will increase the variance of the group. However, in cases where the voltage drops have high variability, a sudden change in a voltage drop may not produce a predictable change in variance of the whole cell.

[0091] Figure 5 shows a graphic of the voltage drop variance computed from the voltage drops of Figure 3. A voltage drop is measured for each anode assembly at each moment (or time interval). The variance of the voltage drop is computed for each moment (or time interval) based on the voltage drop signal. The signal thus obtained is the voltage drop variance.

[0092] In the case of the first shorted anode assembly, the variance actually dropped when the anode assembly was shorted. This can be due to the fact that there was already a low electrical current flowing through the assembly and the short caused it to come closer to the other assemblies, thus reducing the variance. In the case of the second shorted anode assembly, the current was similar to the three others, so the

electrical shorting caused the variance to increase.

[0093] The voltage drop variance technique offers the benefit of tracking a single signal for the electrolytic cell instead of tracking multiple signals.

5 [0094] The voltage drop variance takes into account the voltage drop of each anode assembly of the electrolytic cell. Therefore the voltage drop variance is dependent on all anode assemblies of the electrolytic cell. The voltage drop variance does not allow to identify the location of the thermite reaction.

10 [0095] The voltage drop variance has the characteristics of: having a variable baseline voltage, depending on position of anodes and their number, and depending on the overlapping dimensions of the anode and cathode ACO, etc.

[0096] A further enhancement could be to use the derivative of the variance as a signal processing technique. This technique would reliably predict a sudden change in a voltage drop even if the initial variance is high.

15 [0097] Figure 6 shows a graphic of the derivative of the voltage drop variance computed from the voltage drops of Figure 3.

[0098] Figure 6 illustrates a derivative of the voltage drop variance initially positive, then negative for each simulated thermite reaction. The positive derivative of the voltage drop variance corresponds to the initial rise of the electrical current flowing through the shorted anode assembly. The negative derivative of the voltage drop variance corresponds to the fall of the electrical current at the end of the simulated thermite reaction. In this case, the sign of the variance can be ignored since the derivative depends essentially on the rate of change.

20

[0099] From Figure 6, it can be appreciated that the peaks in the derivative of the voltage drop variance have a high magnitude. Thereby, allowing for a more sensitive detection of a thermite reaction.

25

[00100] The technique based on the derivative of the voltage drop variance offers the benefit of tracking a single signal for the electrolytic cell instead of tracking multiple signals.

[00101] The derivative of the voltage drop variance takes into account the voltage drop of each anode assembly of the electrolytic cell. Therefore the derivative of the voltage drop variance is dependent on all anode assemblies of the electrolytic cell.

30

Consequently, the derivative of the voltage drop variance may not allow to identify the location of the thermite reaction.

[00102] The derivative of the voltage drop variance has the advantages of having a zero baseline voltage and detecting sudden changes in the voltage drop.

5 [00103] One disadvantage of the derivative of the voltage drop variance is that it may not provide a clear information as to the end of the thermite reaction.

[00104] Figure 7 illustrates a detection method 200, based on voltage measurements, to anticipate and react to a potential thermite condition. The method 200 also allows to prevent a sustained thermite reaction. The method 200 takes advantage
10 of derivative and variance terms to enhance the reliability of the voltage drop interpretation.

[00105] The method 200 for detecting a thermite reaction in an electrolytic cell comprises measuring 210 a voltage drop for each anode assembly. The voltage drop corresponds to the current flow in the anode assembly. The voltage drop is measured
15 using a pair of voltage probes located on the anode rod of the anode assembly. The method 200 also comprises computing 220 from the measured voltage drop at least one of a voltage drop derivative 221, a voltage drop variance 222 across the one or more anode assemblies, and a derivative of the voltage drop variance 223 across the one or more anode assemblies. The voltage drop variance and derivative of the voltage drop
20 variance may be computed when the electrolytic cell comprises a plurality of anode assemblies.

[00106] The method 200 may optionally further comprise filtering 225 the voltage drop and/or filtering the voltage drop derivative, the variance of the voltage drop, and the derivative of the voltage drop variance.

25 [00107] The method 200 further comprises detecting 230 a thermite reaction when the voltage drop exceeds at least one voltage threshold level 231. Each voltage threshold level is a predetermined voltage drop previously associated with a thermite reaction. The threshold voltage levels may also be based on past operational data of the electrolytic cell. Alternatively, the threshold voltage levels may be computed from at
30 least one of past operational data of the electrolytic cell, operation parameters, and composition of the electrolytic cell.

[00108] Alternatively or additionally, detecting 230 a thermite reaction may be

performed when a variation in the voltage drop derivative occurs **232**, such as for instance when the variation in voltage drop derivative exceeds a threshold variation.

[00109] Alternatively or additionally, detecting **230** a thermite reaction may be performed when a variation in variance of the voltage drop across the anode assemblies occurs **232**, such as for instance, when the variation in variance of the voltage drop across the anode assemblies exceeds a threshold variation.

[00110] Alternatively or additionally, detecting **230** a thermite reaction may be performed when a steep variation in derivative of the voltage drop variance across the anode assemblies occurs **234**, such, for instance when the variation in derivative of the voltage drop across the anode assemblies exceeds a threshold variation.

[00111] As also illustrated on Figure 7, the method **200** may optionally comprise adjusting **240** one or more operational parameters of the electrolytic cell to mitigate and, ideally, suppress the thermite reaction upon detection of the thermite reaction. Adjusting **240** one or more operational parameter of the electrolytic cell may comprise changing the anode to cathode overlap (ACO) of one or more anode assemblies.

[00112] According to preferred embodiments, adjusting **240** one or more operational parameter of the electrolytic cell to mitigate and, ideally, suppress the thermite reaction may also comprise removing one or more anode assemblies from the electrolytic bath; changing the current supplied to at least one of the one or more anode assemblies or the electrolytic cell; changing a temperature of the electrolytic bath; and/or changing a chemistry of the electrolytic bath.

[00113] According to preferred embodiments,, when the voltage drop of one of the anode assemblies exceeds the at least one voltage threshold level, adjusting **240** one or more operational parameters of the electrolytic cell may take into account one or more of the exceeded voltage threshold levels; the magnitude of the voltage drop; the magnitude of the voltage drop derivative; the magnitude of the variance of the voltage drop; the magnitude of the derivative of the voltage drop variance.

[00114] As aforesaid, the method system and electrolytic cell as disclosed herein are particularly advantageous as they allow reducing the number of voltage signals or drops necessary for detecting a thermite reaction. From preliminary tests, it is expected that the reduction may be achieved by a factor up to 10. Although the method, system and electrolytic cell as disclosed herein use fewer voltage signals or drops, fine tuning

of the location of the voltage probes to gain a better signal to noise ratio is provided. Taking advantage of derivative and variance terms contribute to enhancing the reliability of the signal interpretation. Finally, the system, method and electrolytic cell as disclosed herein are expected to permit reduction in maintenance and operations costs of the electrolytic cell due to a reduction in the number of signals to install and monitor.

[00115] Figure 8 shows a logical modular representation of a system 1000 for detecting a thermite reaction in an electrolytic cell in accordance with the teachings of the present application. As previously discussed, the electrolytic cell comprises at least one anode assembly of one or more metal-oxide oxide-containing anodes, at least one cathode, an electrolytic bath, and a current supply buss providing a current to the at least one anode assembly through a distinct anode rod for each anode assembly. The system 1000 provides an exemplary modular view of the controller 1100 involved in the detecting. The system 1000 may also comprise a remote monitoring station 1200. In some embodiments, the controller 1100 may exchange data with the remote monitoring station 1200 and the controller 1100 is therefore able to exchange one or more message and/or one or more commands with the remote monitoring station 1200.

[00116] In the depicted example of Figure 8, the controller 1100 comprises a memory module 1120, a processor module 1130 and a network interface module 1140. The processor module 1130 may represent a single processor with one or more processor cores or an array of processors, each comprising one or more processor cores. The memory module 1120 may comprise various types of memory (different standardized or kinds of Random Access Memory (RAM) modules, memory cards, Read-Only Memory (ROM) modules, programmable ROM, etc.). The network interface module 1140 represents at least one physical interface that can be used to communicate with other network nodes. The network interface module 1140 may be made visible to the other modules of the controller 1100 through one or more logical interfaces. The actual stacks of protocols used by the physical network interface(s) and/or logical network interface(s) 1142, 1144, 1146, 1148 of the network interface module 1140 do not affect the teachings of the present application. The variants of processor module 1130, memory module 1120 and network interface module 1140 usable in the context of the present application will be readily apparent to persons skilled in the art.

[00117] A bus 1170 is depicted as an example of means for exchanging data between the different modules of the controller 1100. The present invention is not affected by the way the different modules exchange information between them. For instance, the memory module 1120 and the processor module 1130 could be connected
5 by a parallel bus, but could also be connected by a serial connection or involve an intermediate module (not shown) without affecting the teachings of the present invention.

[00118] Likewise, even though explicit mentions of the memory module 1120 and/or the processor module 1130 are not made throughout the description of the
10 various embodiments, persons skilled in the art will readily recognize that such modules are used in conjunction with other modules of the controller 1100 to perform routine as well as innovative steps related to the present invention.

[00119] The controller 1100 may also comprise an optional Graphical User Interface (GUI) module 1150 comprising one or more display screen(s) forming a
15 display system, for the controller 1100. The display screens of the GUI module 1150 could be split into one or more flat panels, but could also be a single flat or curved screen visible from an expected user position (not shown). Skilled persons will readily understand that the GUI module 1150 may be used in a variety of contexts not limited to the previously mentioned examples.

[00120] The system 1000 may comprise a data storage system 1500 that comprises
20 data related to brick positioning and may further log data while the production is performed. Figure 8 shows examples of the storage system 1500 as a distinct database system 1500A, a distinct module 1500B of the controller 1100 or a sub-module 1500C of the memory module 1120 of the controller 1100. The storage system 1500 may also
25 comprise storage modules (not shown) on the remote monitoring station 1200. The storage system 1500 may be distributed over different systems A, B, C and/or the remote monitoring station 1200 or may be in a single system. The storage system 1500 may comprise one or more logical or physical as well as local or remote hard disk drive (HDD) (or an array thereof). The storage system 1500 may further comprise a local or
30 remote database made accessible to the controller 1100 by a standardized or proprietary interface or via the network interface module 1140. The variants of the storage system 1500 usable in the context of the present invention will be readily apparent to persons skilled in the art.

[00121] A measurement input module 1160 and an optional control module 1161 are provided in the controller 1100. The measurement input module 1160 and the control module 1161 will be referred to hereinbelow as distinct logical modules, but skilled person will readily recognize that a single logical module may have been shown
5 instead.

[00122] In some embodiment, an optional external input/output (I/O) module 1162 and/or an optional internal input/output (I/O) module 1164 may be provided with the measurement input module 1160 and the control module 1161. The external I/O module 1162 may be required, for instance, for interfacing with one or more robots, one or more
10 input device (e.g., measurement probe) and/or one or more output device (e.g., printer). The internal input/output (I/O) module 1164 may be required, for instance, for interfacing the controller 1100 with one or more instruments or controls (not shown) typically used in the context of electrolysis cell control (e.g., probes). The I/O module 1164 may comprise necessary interface(s) to exchange data, set data or get data from
15 such instruments or controls.

[00123] The measurement input module 1160 and processor module 1130 are tightly related to the detection of the thermite reaction. In the example of the system 1000, the measurement input module 1160 and the processor module 1130 may be involved in various step of a method 200 described hereinabove.

[00124] While illustrative and presently preferred embodiments have been described in detail hereinabove, it is to be understood that the inventive concepts may be otherwise variously embodied and employed and that the appended claims are intended to be construed to include such variations except insofar as limited by the prior
20 art.

25

21

Claims

1. A method for detecting a thermite reaction in an electrolytic cell comprising at least one anode assembly of one or more metal-oxide-containing anodes, at least one cathode, an electrolytic bath, and a current supply buss providing a current to the at least one anode assembly through a distinct anode rod for each anode assembly, the method comprising:
- 5
- measuring a voltage drop using at least one pair of voltage probes located on the anode rod of each anode assembly, the voltage drop corresponding to a current flow in each anode assembly;
 - 10 - computing from the measured voltage drop at least one of:
 - o a voltage drop derivative,
 - o a voltage drop variance across the one or more anode assemblies; and
 - o a derivative of the voltage drop variance across the one or more anode assemblies,
- 15
- wherein the at least one of the voltage drop derivative, the voltage drop variance and the derivative of the voltage drop variance are computed when the electrolytic cell comprises a plurality of anode assemblies; and
- detecting the thermite reaction upon occurrence of one or more of:
 - 20 o a voltage drop exceeding at least one voltage threshold level, wherein each voltage threshold level is a predetermined voltage drop previously associated with a thermite reaction;
 - o a variation in the voltage drop derivative;
 - o a variation in the variance of the voltage drop across the anode assemblies; and
 - 25 o a variation in the derivative of the voltage drop variance across the anode assemblies.
2. The method of claim 1, further comprising, upon detection of the thermite reaction, adjusting at least one operational parameter of the electrolytic cell to mitigate and/or suppress the thermite reaction.
- 30

3. The method of claim 1 or 2, further comprising sending a signal to an operator of the electrolytic cell upon detection of the thermite reaction.
4. The method of any one of claims 1 to 3, wherein the threshold voltage levels are based on past operational data of the electrolytic cell.
5. The method of any one of claims 1 to 3, wherein the threshold voltage levels are computer derived threshold levels derived from at least one of past operational data of the electrolytic cell, operation parameters, and composition of the electrolytic cell.
6. The method of any one of claims 1 to 5, wherein the thermite reaction is detected when:
 - 10 - the variation in voltage drop exceeds a threshold variation;
 - the variation in voltage drop derivative exceeds the threshold variation;
 - the variation in variance of the voltage drop across the anode assemblies exceeds the threshold variation; and/or
 - the variation in derivative of the voltage drop across the anode assemblies
15 exceeds the threshold variation.
7. The method of any one of claims 1 to 6, wherein adjusting at least one operational parameter of the electrolytic cell to mitigate and/or suppress the thermite reaction comprises one or more of:
 - changing an anode to cathode overlap (ACO) of one or more anode assemblies;
 - 20 - removing one or more anode assemblies from the electrolytic bath;
 - changing the current supplied to at least one of the one or more anode assemblies or the electrolytic cell;
 - changing a temperature of the electrolytic bath; and
 - changing a chemistry of the electrolytic bath.
- 25 8. The method of any one of claims 1 to 7, wherein, when the voltage drop of one of the anode assemblies exceeds the at least one voltage threshold level, adjusting at least one operational parameter of the electrolytic cell takes into account one or more of the exceeded voltage threshold levels.
9. The method of any one of claims 1 to 8, wherein, upon detection of the thermite

23

reaction, adjusting at least one operational parameter of the electrolytic cell takes into account:

- a magnitude of the voltage drop;
- a magnitude of the voltage drop derivative;
- 5 - a magnitude of the variance of the voltage drop; and/or
- a magnitude of the derivative of the voltage drop variance.

10. The method of any one of claims 1 to 8, further comprising:

filtering the voltage drop, the voltage drop derivative, the variance of the voltage drop, and/or the derivative of the voltage drop variance.

10 11. A system for detecting a thermite reaction in an electrolytic cell comprising at least one anode assembly of one or more metal-oxide-containing anodes, at least one cathode, an electrolytic bath, and a current supply buss providing a current to the at least one anode assembly through a distinct anode rod for each of the at least one anode assembly, the system comprising:

15 a measurement module comprising, for each of the at least one anode assembly, a pair of voltage probes located on the anode rod of the anode assembly for measuring a voltage drop, the voltage drop corresponding to a current flow in the anode assembly; and

a processor module configured to:

- 20 ○ compute from the measured voltage drop at least one of:
- a voltage drop derivative;
 - a voltage drop variance across the one or more anode assemblies; and
 - a derivative of the voltage drop variance across the one or
 - 25 more anode assemblies;

wherein the at least one of the voltage drop derivative, the voltage drop variance and the derivative of the voltage drop variance are computed when the electrolytic cell comprises a plurality of anode assemblies; and

- detecting the thermite reaction upon occurrence of one or more of:
 - a voltage drop exceeding at least one voltage threshold level, wherein each voltage threshold level is a predetermined voltage drop previously associated with a thermite reaction;
 - 5 - a variation in voltage drop derivative;
 - a variation in variance of the voltage drop across the anode assemblies; and
 - a variation in derivative of the voltage drop variance across the anode assemblies.
- 10 12. The system of claim 11, further comprising a network interface module operatively connected to the processor module for sending a signal to an operator of the electrolytic cell upon detection of the thermite reaction.
- 13. The system of claim 11 or 12, wherein the threshold voltage levels are based on past operational data of the electrolytic cell.
- 15 14. The system of any one of claims 11 to 13, wherein the threshold voltage levels are computer derived threshold levels derived from at least one of past operational data of the electrolytic cell, operation parameters, and composition of the electrolytic cell.
- 15. The system of any one of claims 11 to 14, wherein the processor module is configured to detect the thermite reaction when the variation in voltage drop derivative
 - 20 exceeds a threshold variation.
- 16. The system of any one of claims 11 to 15, wherein the processor module is configured to detect the thermite reaction when:
 - the variation in voltage drop exceeds a threshold variation;
 - the variation in voltage drop derivative exceeds the threshold variation;
 - 25 - the variation in variance of the voltage drop across the anode assemblies exceeds the threshold variation; and /or
 - the variation in derivative of the voltage drop variance across the anode assemblies exceeds the threshold variation.
- 17. The system of anyone of claims 11 to 16, further comprising a control module

operatively connected to the processor module configured to adjust at least one operational parameter of the electrolytic cell to mitigate and/or suppress the thermite reaction by:

- changing an anode to cathode overlap (ACO) of one or more anode assemblies;
- 5 - removing one or more anode assemblies from the electrolytic bath;
- changing the current supplied to at least one of the one or more anode assemblies or the electrolytic cell;
- changing a temperature of the electrolytic bath; and/or
- changing a chemistry of the electrolytic bath.

10 18. The system of any one of claims 11 to 17, wherein, when the voltage drop of one of the anode assemblies exceeds the at least one voltage threshold level, the processor module is configured to adjust at least one operational parameter of the electrolytic cell by taking into account one or more of the exceeded voltage threshold levels.

15 19. The system of any one of claims 11 to 18, wherein, upon detection of the thermite reaction, the processor module is configured to adjust at least one operational parameter of the electrolytic cell taking into account:

- a magnitude of the voltage drop;
- a magnitude of the voltage drop derivative;
- a magnitude of the variance of the voltage drop; and/or
- 20 - a magnitude of the derivative of the voltage drop variance.

20. The system of any one of claims 11 to 19, wherein the processor module is further configured to filter the voltage drop, the voltage drop derivative, the variance of the voltage drop, and/or the derivative of the voltage drop variance.

25 21. An electrolytic cell comprising at least one anode assembly of one or more metal-oxide-containing anodes, at least one cathode, an electrolytic bath, and a current supply buss providing a current to the at least one anode assembly through a distinct anode rod for each anode assembly, and the system for detecting a thermite reaction as claimed in any one of claims 11 to 20.

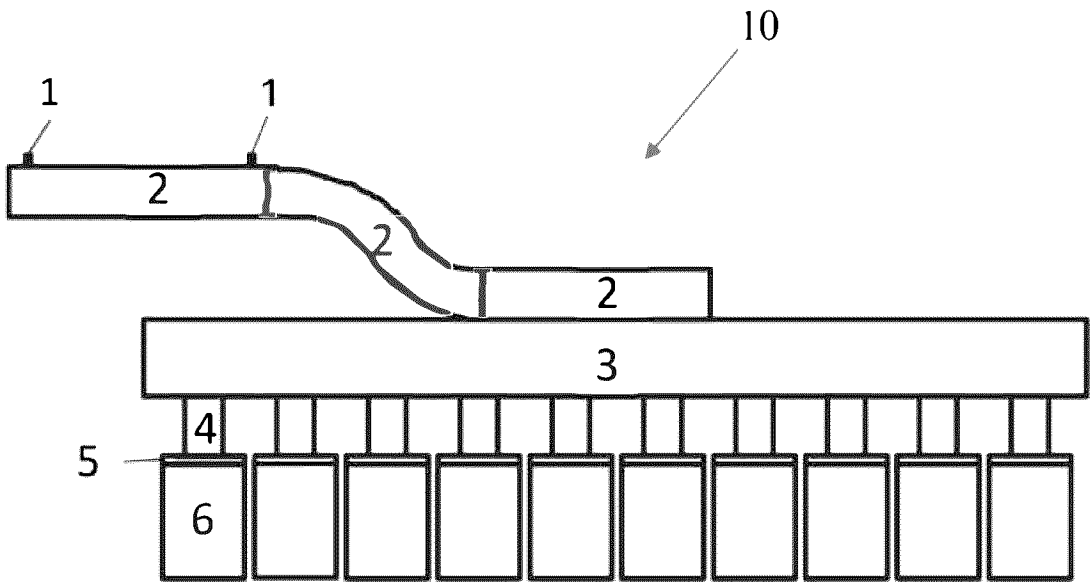

FIG. 1

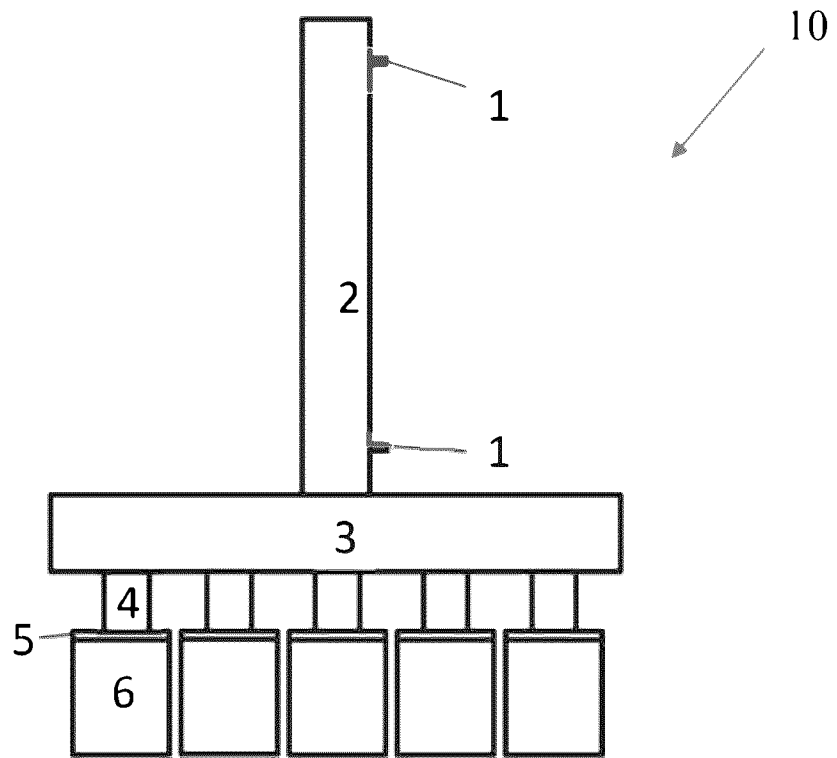

FIG. 2

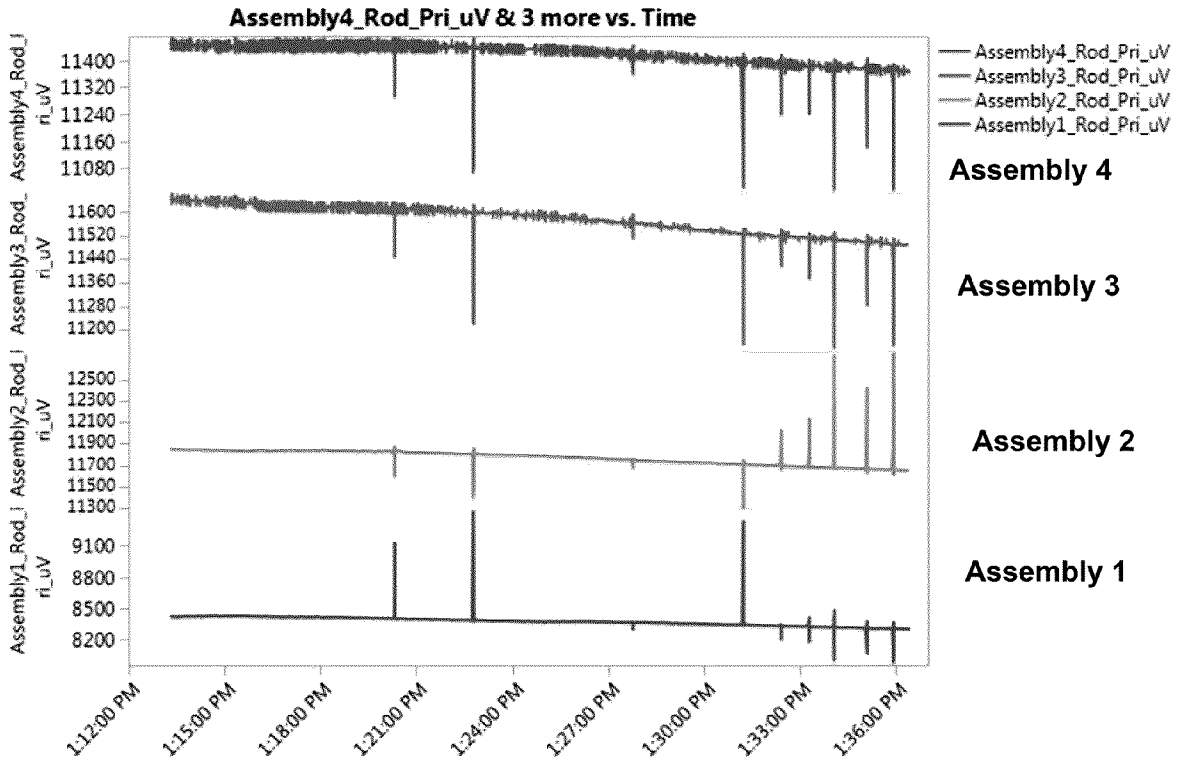

FIG. 3

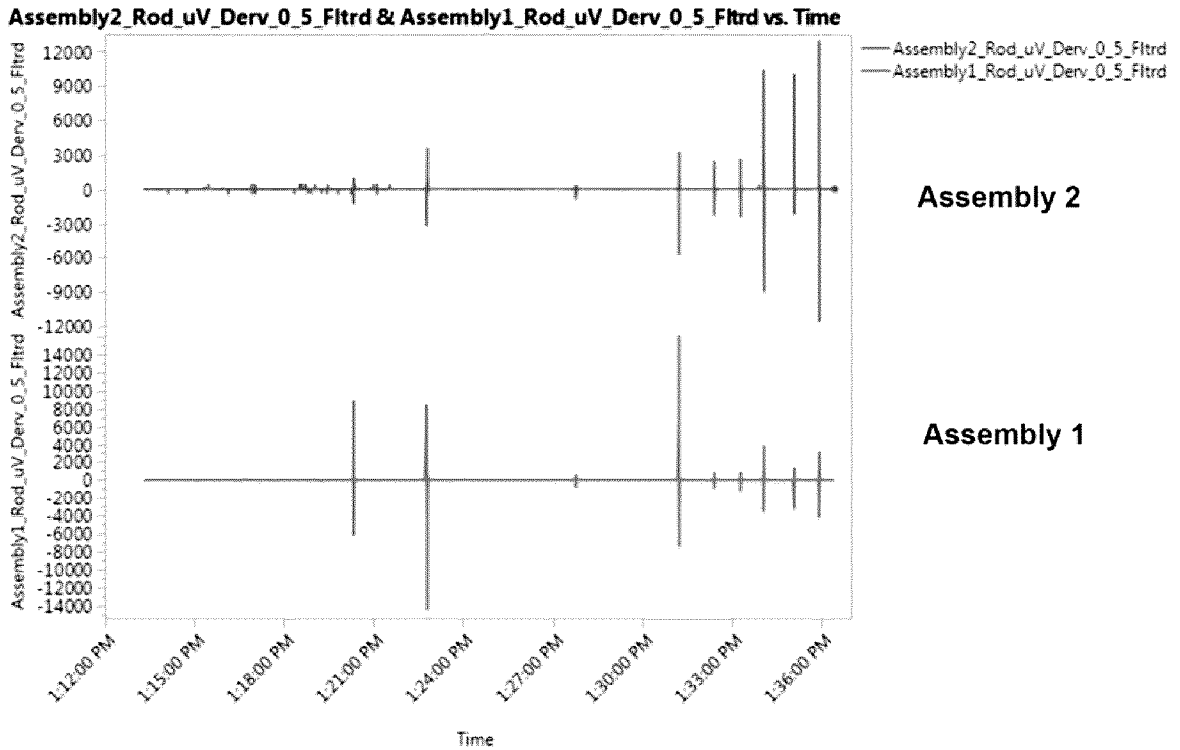

FIG. 4

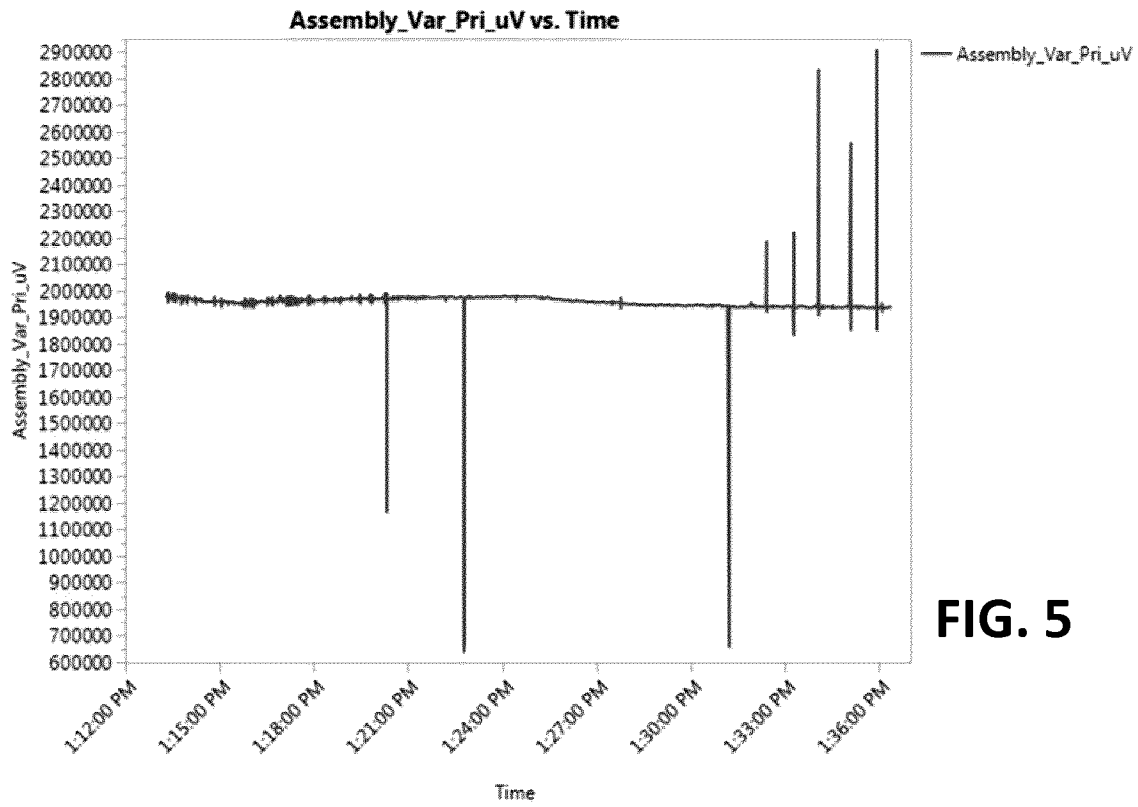

FIG. 5

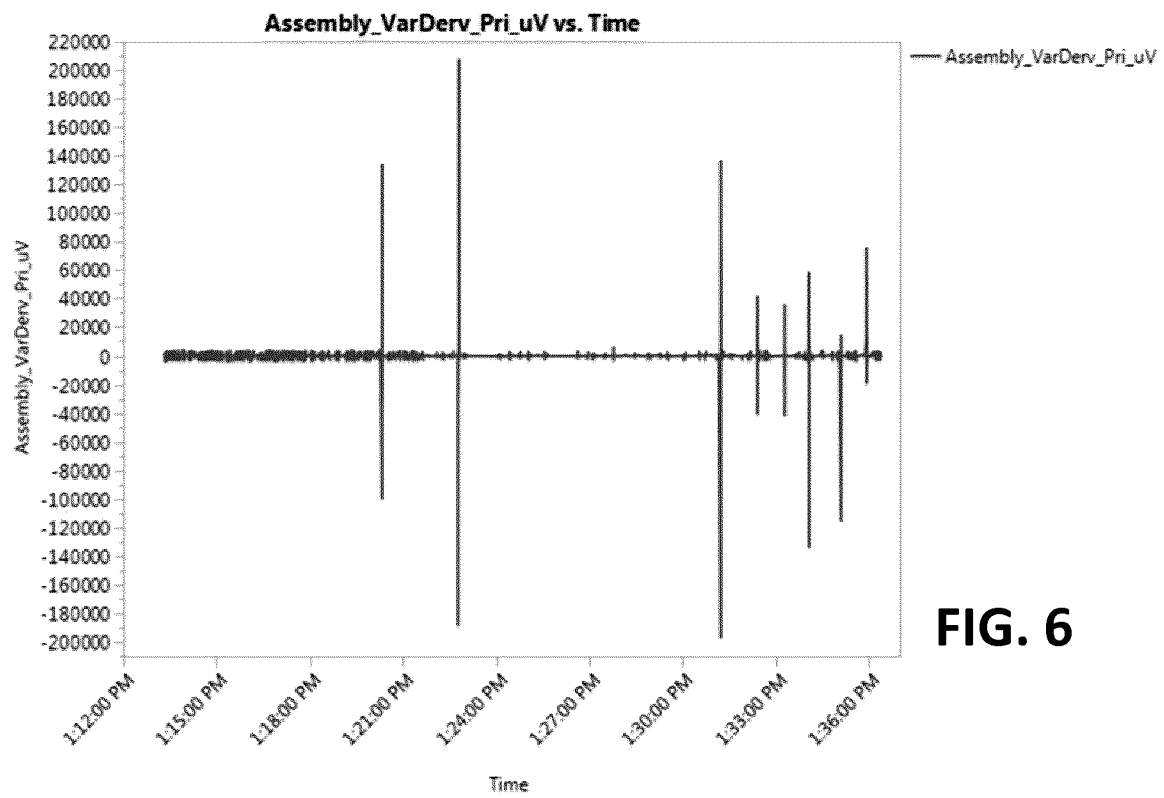

FIG. 6

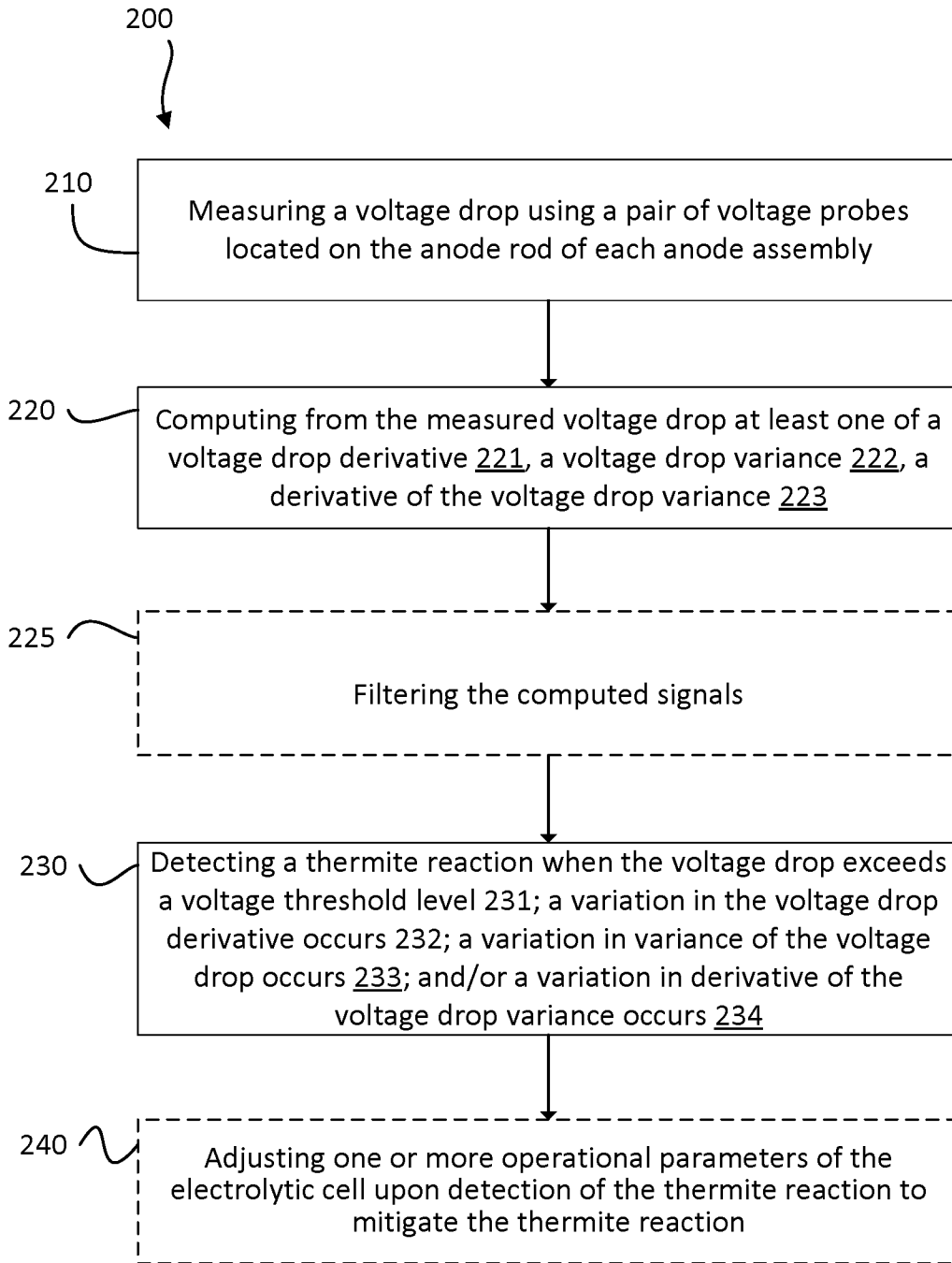

FIG. 7

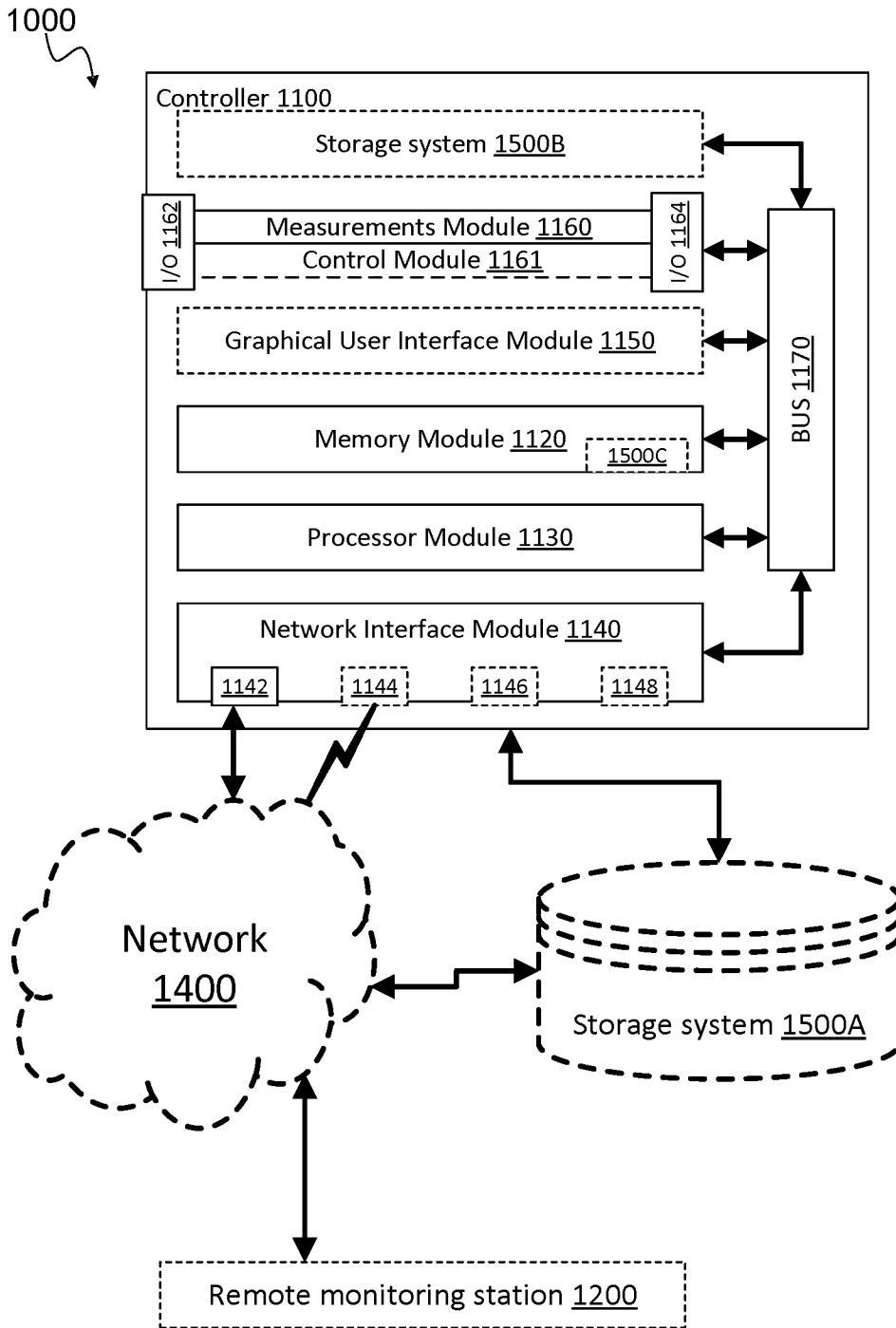

FIG. 8

INTERNATIONAL SEARCH REPORT

International application No.

PCT/CA2021/051512

A. CLASSIFICATION OF SUBJECT MATTER

IPC: *G01N 27/416* (2006.01), *C25C 3/12* (2006.01), *C25C 3/16* (2006.01), *C25C 3/20* (2006.01)

CPC:

According to International Patent Classification (IPC) or to both national classification and IPC

B. FIELDS SEARCHED

Minimum documentation searched (classification system followed by classification symbols)
Keywords applied across all IPCs

Documentation searched other than minimum documentation to the extent that such documents are included in the fields searched

Electronic database(s) consulted during the international search (name of database(s) and, where practicable, search terms used)

Database: Questel – Orbit

Keywords: thermite, electrolytic cell, voltage drop, derivative, anode, variance

C. DOCUMENTS CONSIDERED TO BE RELEVANT

Category*	Citation of document, with indication, where appropriate, of the relevant passages	Relevant to claim No.
X	US 2014 0048421 A1 (D'ASTOLFO JR. et al.) 20 February 2014 (20-02-2014) * whole document	1-21

 Further documents are listed in the continuation of Box C. See patent family annex.

* "A" "D" "E" "L" "O" "P"	Special categories of cited documents: document defining the general state of the art which is not considered to be of particular relevance document cited by the applicant in the international application earlier application or patent but published on or after the international filing date document which may throw doubts on priority claim(s) or which is cited to establish the publication date of another citation or other special reason (as specified) document referring to an oral disclosure, use, exhibition or other means document published prior to the international filing date but later than the priority date claimed	"T" "X" "Y" "&"	later document published after the international filing date or priority date and not in conflict with the application but cited to understand the principle or theory underlying the invention document of particular relevance; the claimed invention cannot be considered novel or cannot be considered to involve an inventive step when the document is taken alone document of particular relevance; the claimed invention cannot be considered to involve an inventive step when the document is combined with one or more other such documents, such combination being obvious to a person skilled in the art document member of the same patent family
---	--	--------------------------	--

Date of the actual completion of the international search
03 January 2022 (03-01-2022)Date of mailing of the international search report
02 February 2022 (02-02-2022)Name and mailing address of the ISA/CA
Canadian Intellectual Property Office
Place du Portage I, C114 - 1st Floor, Box PCT
50 Victoria Street
Gatineau, Quebec K1A 0C9
Facsimile No.: 819-953-2476

Authorized officer

Brian Truong (873) 354-9794

INTERNATIONAL SEARCH REPORT
Information on patent family members

International application No.
PCT/CA2021/051512

Patent Document Cited in Search Report	Publication Date	Patent Family Member(s)	Publication Date
US2014048421A1	20 February 2014 (20-02-2014)	US9982355B2	29 May 2018 (29-05-2018)
		AU2013303221A1	11 December 2014 (11-12-2014)
		AU2013303221B2	19 November 2015 (19-11-2015)
		BR112015000194A2	27 June 2017 (27-06-2017)
		BR112015000194B1	18 May 2021 (18-05-2021)
		CA2874252A1	20 February 2014 (20-02-2014)
		CA2874252C	04 October 2016 (04-10-2016)
		CN104471116A	25 March 2015 (25-03-2015)
		CN104471116B	01 January 2019 (01-01-2019)
		DK201570139A1	13 April 2015 (13-04-2015)
		EP2885444A1	24 June 2015 (24-06-2015)
		EP2885444A4	04 May 2016 (04-05-2016)
		EP2885444B1	09 October 2019 (09-10-2019)
		ES2764000T3	01 June 2020 (01-06-2020)
		IN2741KON2014A	08 May 2015 (08-05-2015)
		RU2015108749A	10 October 2016 (10-10-2016)
		RU2626517C2	28 July 2017 (28-07-2017)
		SA515360034B1	09 April 2017 (09-04-2017)
		WO2014028045A1	20 February 2014 (20-02-2014)