



US00D458564S

(12) **United States Design Patent**
Lin

(10) **Patent No.:** **US D458,564 S**

(45) **Date of Patent:** **** Jun. 11, 2002**

(54) **BELT WHEEL**

Primary Examiner—Antoine Duval Davis

(76) **Inventor:** **Kuen Chyr Lin**, 1, Alley 16, Lane 40,
Jinn Te Rd., Taichung (TW)

(57) **CLAIM**

(**) **Term:** **14 Years**

The ornamental design for a belt wheel, as shown and described.

(21) **Appl. No.:** **29/138,531**

DESCRIPTION

(22) **Filed:** **Mar. 16, 2001**

(51) **LOC (7) Cl.** **12-11**

FIG. 1 is a front-right-top perspective view of a belt wheel, showing my new design;

(52) **U.S. Cl.** **D12/114; D21/563; D21/423**

FIG. 2 is a front elevational view thereof;

(58) **Field of Search** **D15/138, 199;**

FIG. 3 is a rear elevational view thereof;

D12/205, 207, 208, 209, 114; D21/563,
779, 423; 280/87.01, 87.02, 210; 188/18 A,
17, 22; 301/6.1, 6.8, 6.5, 6.9, 1, 5.24, 5.306,
5.307

FIG. 4 is a left side elevational view thereof;

FIG. 5 is a right side elevational view thereof;

(56) **References Cited**

FIG. 6 is a top view thereof; and,

FIG. 7 is a bottom plan view thereof.

U.S. PATENT DOCUMENTS

D301,157 S * 5/1989 Hess D21/423

* cited by examiner

1 Claim, 7 Drawing Sheets

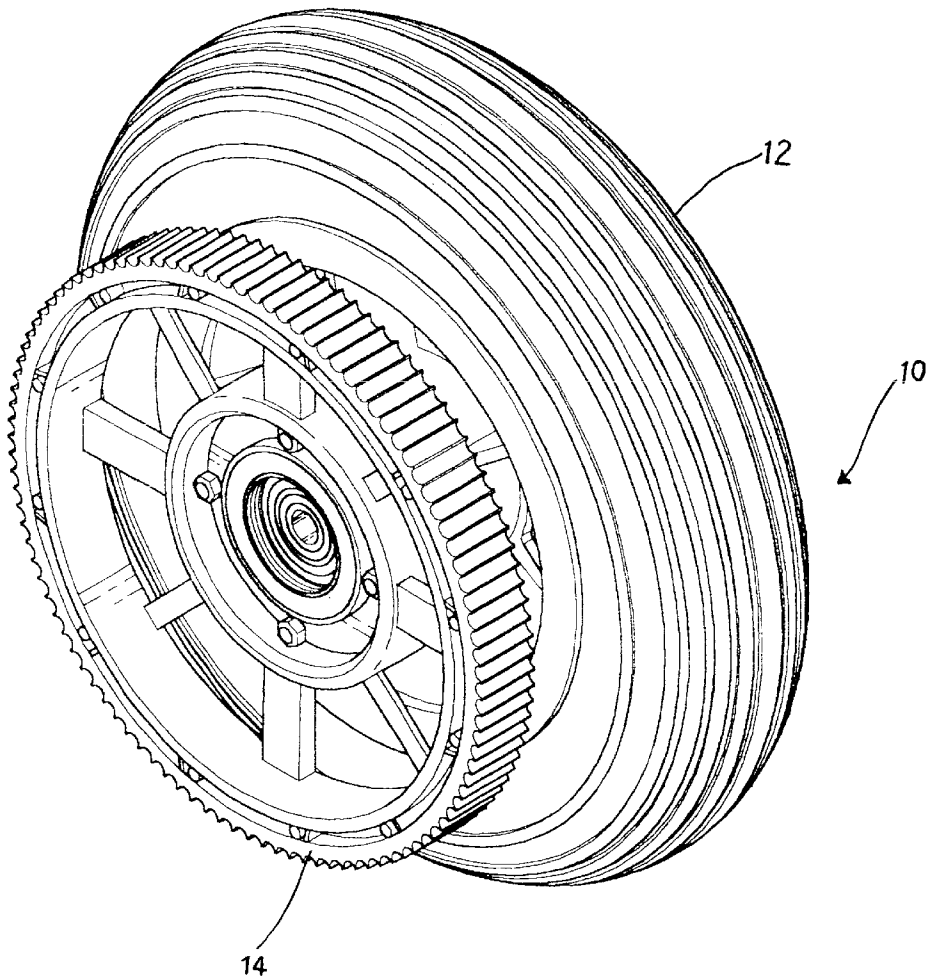

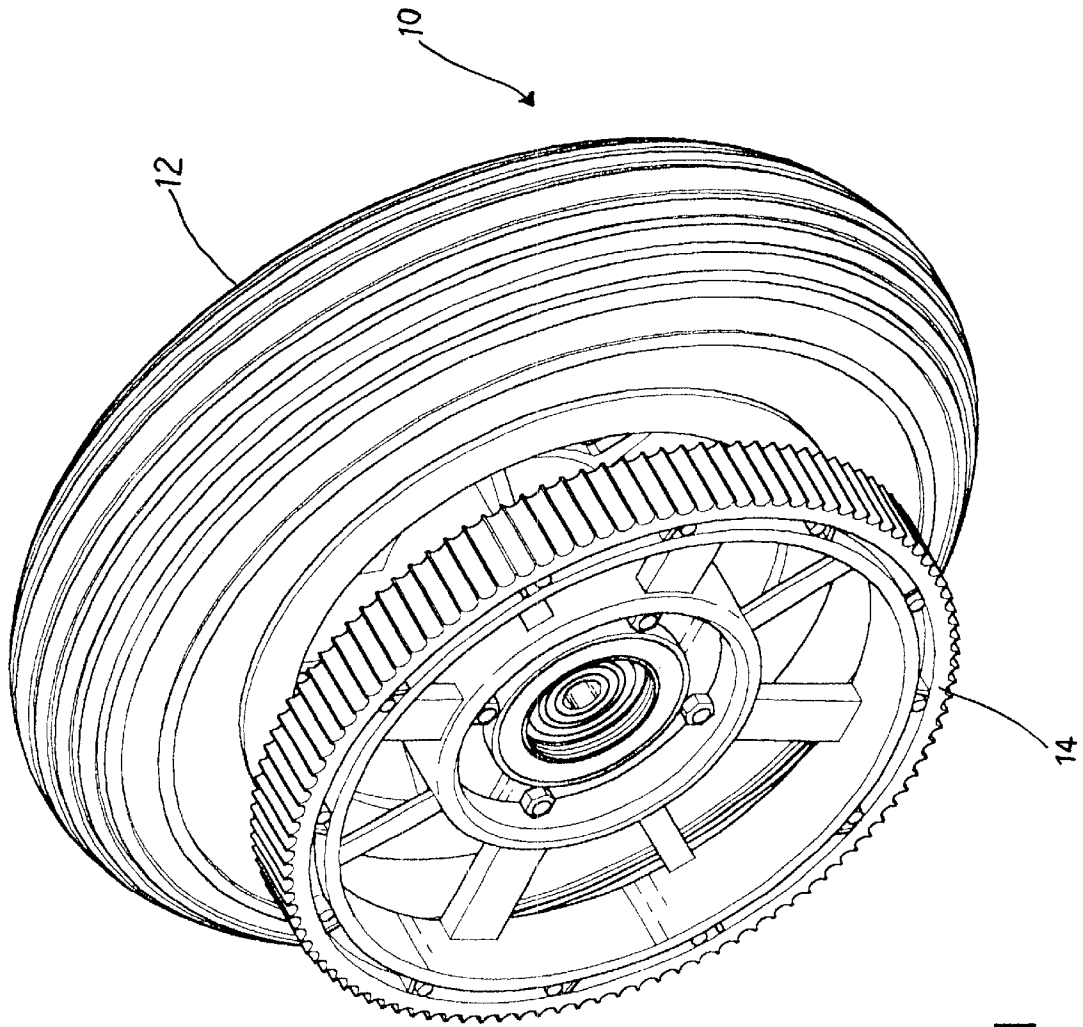

Fig:1

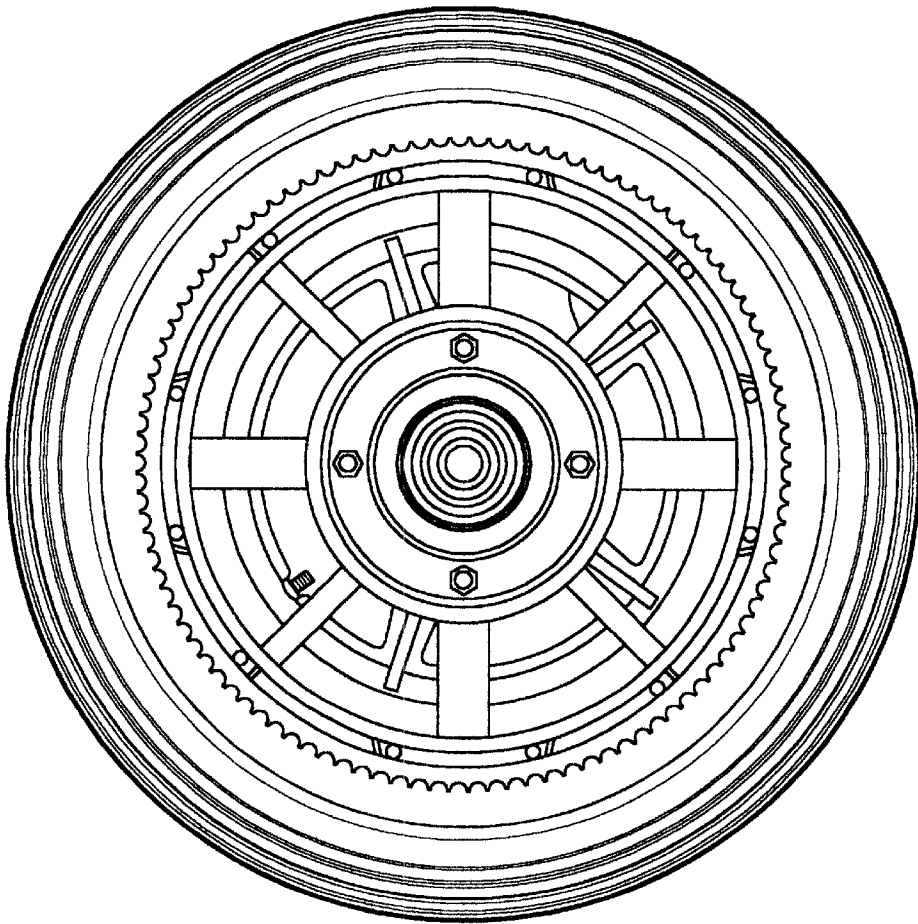

Fig:2

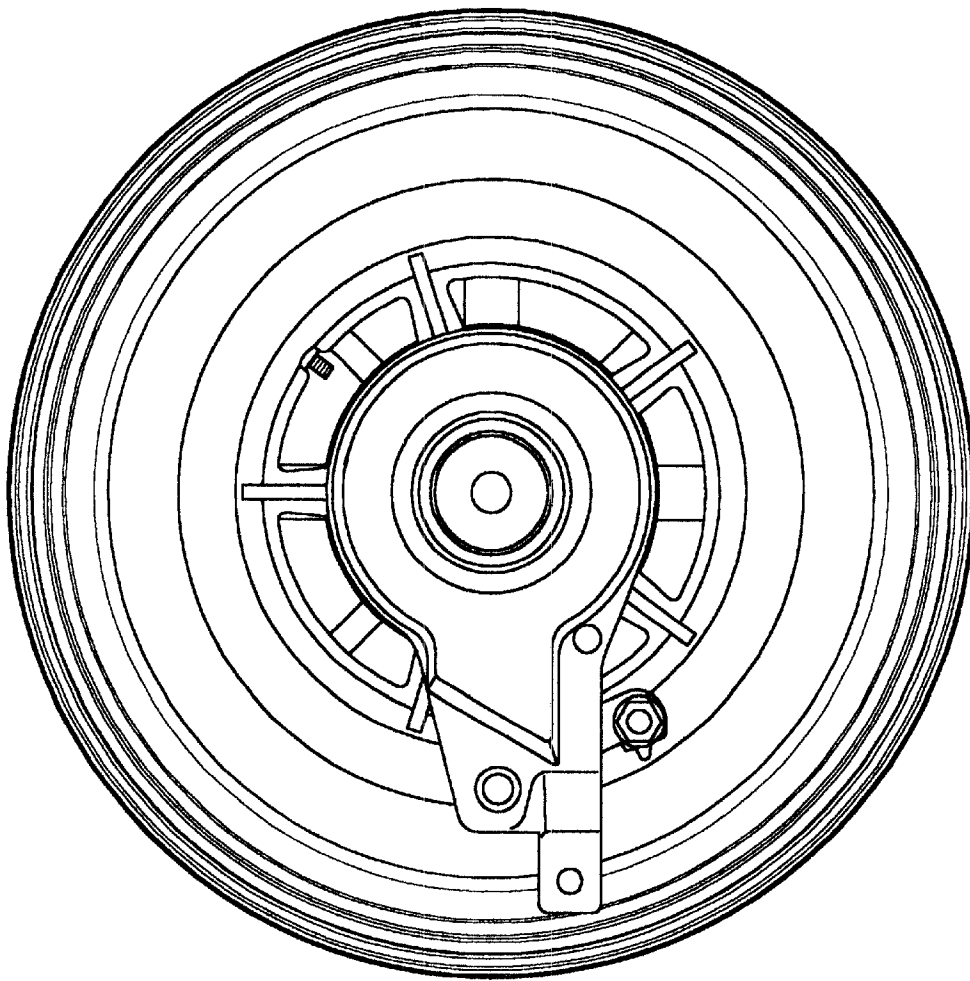

Fig:3

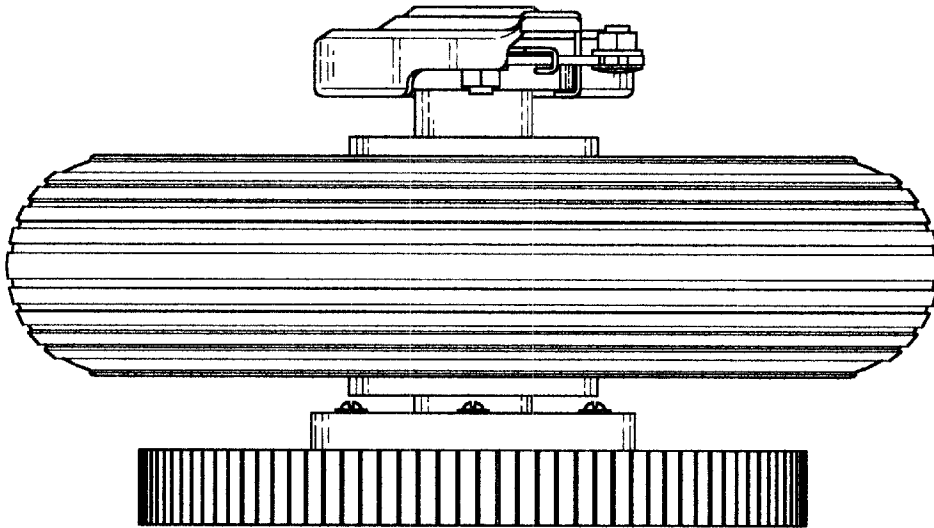

Fig:4

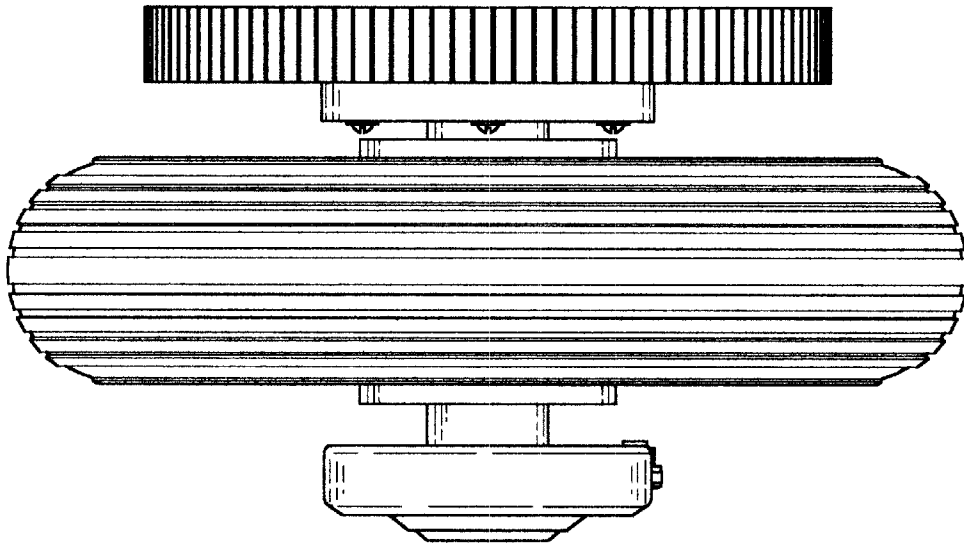

Fig:5

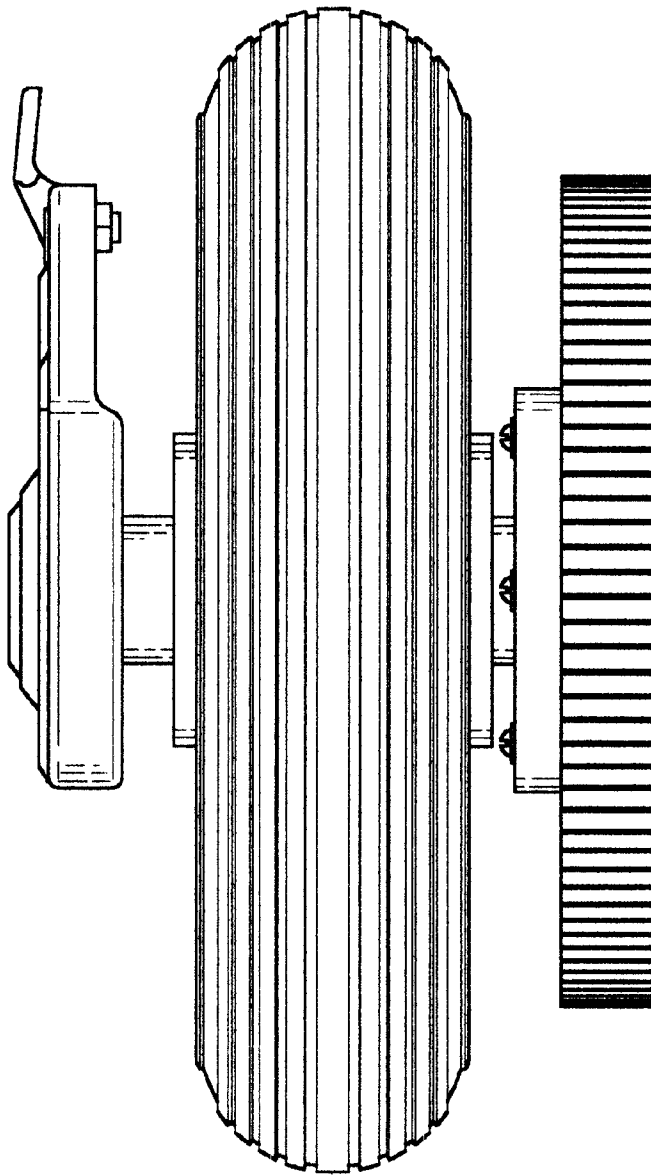

Fig:6

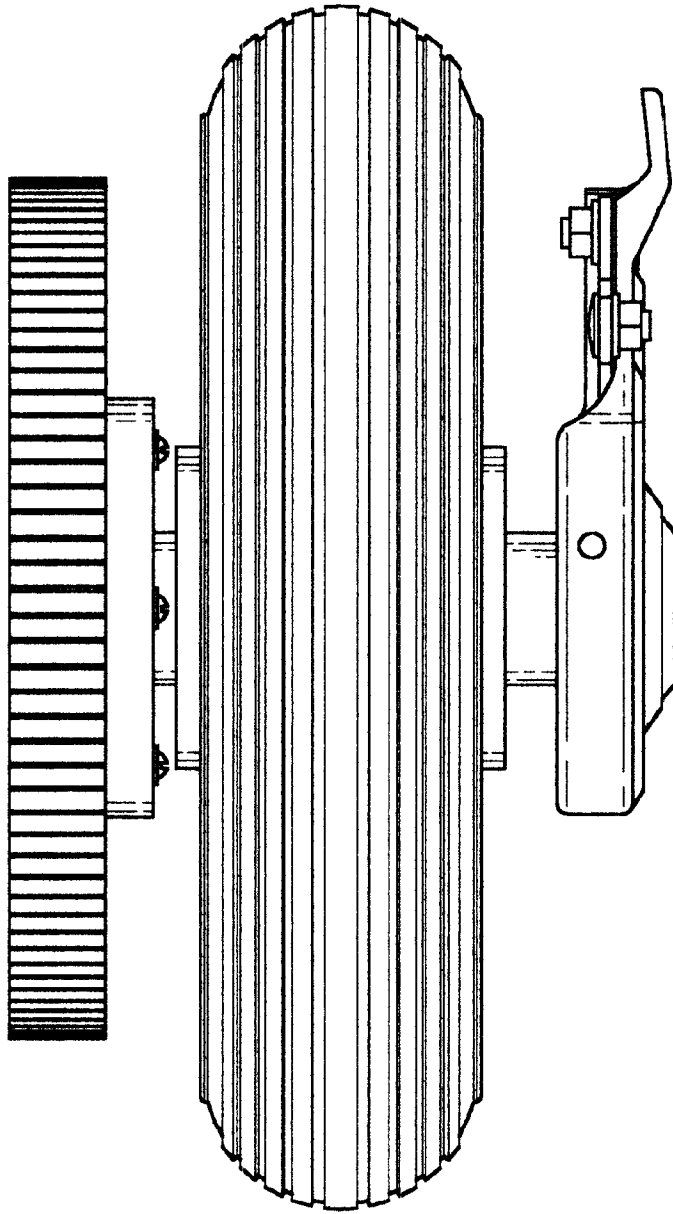

Fig:7