



- (51) **International Patent Classification:**
A61B 18/20 (2006.01)
- (21) **International Application Number:**
PCT/US2010/043117
- (22) **International Filing Date:**
23 July 2010 (23.07.2010)
- (25) **Filing Language:** English
- (26) **Publication Language:** English
- (30) **Priority Data:**

61/228,529	24 July 2009 (24.07.2009)	US
61/228,560	25 July 2009 (25.07.2009)	US
- (71) **Applicant (for all designated States except US):**
LENSAR, INC. [US/US]; 250 S. Park Avenue, Suite 310, Winter Park, FL 32789 (US).
- (72) **Inventors; and**
- (75) **Inventors/Applicants (for US only):** FREY, Rudolph, W. [US/US]; 1356 W. Lake Colony Drive, Maitland, FL 32751-6119 (US). BOTT, Steven, E. [US/US]; 472 W. Palm Valley Drive, Oviedo, FL 32765 (US). GRAY, Gary, P. [US/US]; 12859 Sharp Shined Street, Orlando, FL 32837 (US).
- (74) **Agent:** FREEMAN, John, C.; Brinks Hofer Gilson & Li-one, P.O. Box 10087, Chicago, IL 60610 (US).
- (81) **Designated States (unless otherwise indicated, for every kind of national protection available):** AE, AG, AL, AM, AO, AT, AU, AZ, BA, BB, BG, BH, BR, BW, BY, BZ, CA, CH, CL, CN, CO, CR, CU, CZ, DE, DK, DM, DO, DZ, EC, EE, EG, ES, FI, GB, GD, GE, GH, GM, GT, HN, HR, HU, ID, IL, IN, IS, JP, KE, KG, KM, KN, KP, KR, KZ, LA, LC, LK, LR, LS, LT, LU, LY, MA, MD, ME, MG, MK, MN, MW, MX, MY, MZ, NA, NG, NI, NO, NZ, OM, PE, PG, PH, PL, PT, RO, RS, RU, SC, SD, SE, SG, SK, SL, SM, ST, SV, SY, TH, TJ, TM, TN, TR, TT, TZ, UA, UG, US, UZ, VC, VN, ZA, ZM, ZW.
- (84) **Designated States (unless otherwise indicated, for every kind of regional protection available):** ARIPO (BW, GH, GM, KE, LR, LS, MW, MZ, NA, SD, SL, SZ, TZ, UG, ZM, ZW), Eurasian (AM, AZ, BY, KG, KZ, MD, RU, TJ, TM), European (AL, AT, BE, BG, CH, CY, CZ, DE, DK, EE, ES, FI, FR, GB, GR, HR, HU, IE, IS, IT, LT, LU, LV, MC, MK, MT, NL, NO, PL, PT, RO, SE, SI, SK, SM, TR), OAPI (BF, BJ, CF, CG, CI, CM, GA, GN, GQ, GW, ML, MR, NE, SN, TD, TG).

[Continued on next page]

(54) **Title:** SYSTEM AND METHOD FOR PROVIDING LASER SHOT PATTERNS TO THE LENS OF AN EYE

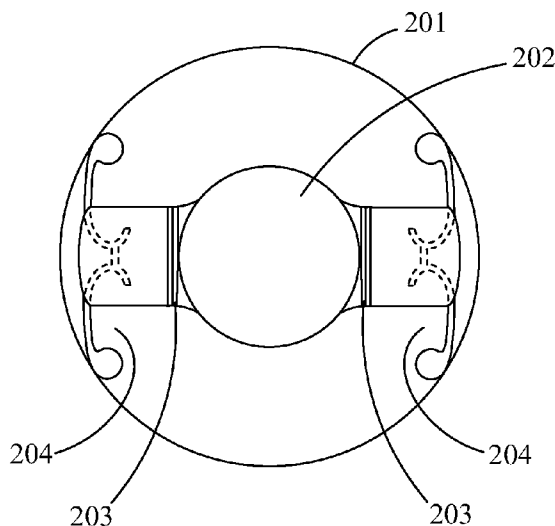

Fig. 8

(57) **Abstract:** There is provided a system, apparatus and methods for developing laser systems that can create precise predetermined shot patterns for providing areas of varying softness in the lens of an eye. These areas of varying softness may have shapes that correspond to instruments used to remove material from the lens of the eye. There is further provided a multiplicity of spheres pattern, which may provide for bubble formation which in turn lubricates the lens material for removal after sectioning.



Published:

— with international search report (Art. 21(3))

SYSTEM AND METHOD FOR PROVIDING LASER SHOT PATTERNS TO THE LENS
OF AN EYE

5 **[0001]** This application claims the benefit of priority under 35 U.S.C. §
119(e)(1) of 1) U.S. Provisional Application Serial Number 61/228,560 titled
System and Method for Providing Laser Shot Patterns to the Lens of an Eye, filed
July 25, 2009 and 2) U.S. Provisional Application Serial Number 61/228,529 titled
System and Method for Providing Laser Shot Patterns to the Lens of an Eye, filed
10 July 24, 2009, and this application is a continuation-in-part application of both 1)
U.S. Patent Application Serial Number 12/217,285, titled System and Method for
Improving the Accommodative Amplitude and Increasing the Refractive Power of
the Human Lens with a Laser, filed July 2, 2008 (now pending), which claims the
benefit of priority of the filing date of PCT/US2007/001353 filed January 19, 2007,
15 and 2) U.S. Patent Application Serial Number 12/217,295 titled System and
Apparatus for Delivering a Laser Beam to the Lens of an Eye, filed July 2, 2008
(now pending), which claims the benefit of priority of the filing date of
PCT/US2007/001486 filed January 19,2007, wherein U.S. Patent Application
Serial Number 12/217,285 is a continuation-in-part application of both 1) U.S.
20 Patent Application Serial Number 11/414,838 titled System and Method for
Providing the Shaped Structural Weakening of the Human Lens with a Laser, filed
May 1, 2006 (now pending), which is a continuation-in-part application of U.S.
Patent Application Serial Number 11/337,127 titled System and Method for
Treating the Structure of the Human Lens, filed January 20, 2006 (now pending),
25 and 2) U.S. Patent Application Serial Number 11/414,819 titled System and
Apparatus for Treating the Lens of an Eye, filed May 1, 2006 (now pending), which
is a continuation-in-part application of U.S. Patent Application Serial Number
11/337,127 titled System and Method for Treating the Structure of the Human
Lens, filed January 20, 2006 (now pending), and wherein U.S. Patent Application
30 Serial Number 12/217,295 is a continuation-in-part application of both 1) U.S.
Patent Application Serial Number 11/414,838 titled System and Method for
Providing the Shaped Structural Weakening of the Human Lens with a Laser, filed

May 1, 2006 (now pending), which is a continuation-in-part application of U.S. Patent Application Serial Number 11/337,127 titled System and Method for Treating the Structure of the Human Lens, filed January 20, 2006 (now pending), and 2) U.S. Patent Application Serial Number 11/414,819 titled System and Apparatus for Treating the Lens of an Eye, filed May 1, 2006 (now pending), which is a continuation-in-part application of U.S. Patent Application Serial Number 11/337,127 titled System and Method for Treating the Structure of the Human Lens, filed January 20, 2006 (now pending), the entire contents of each of which is incorporated herein by reference.

BACKGROUND OF THE INVENTION

[0002] The present invention relates to methods and systems for improving procedures that address cataracts, opacifications in the lens, clear lens extraction, removal of natural lens material, use of lens replacement materials and combinations of these. The present invention additionally relates to systems and methods that provide predetermined, precise and reproducible laser shot patterns for creating incisions in the natural human crystalline lens that are reproducible from patient-to-patient and surgeon-to-surgeon.

[0003] In general, presbyopia is the loss of accommodative amplitude. In general, cataracts are areas of opacification within the crystalline lens, which are sufficient to interfere with vision. Other conditions, for which the present invention is directed, include but are not limited to the opacification of the crystalline lens.

[0004] Presbyopia most often presents as a near vision deficiency, the inability to read small print, especially in dim lighting after about 40-45 years of age. Presbyopia, or the loss of accommodative amplitude with age, relates to the eyes inability to change the shape of the natural crystalline lens, which allows a person to change focus between far and near, and occurs in essentially 100% of the population over age 45. Accommodative amplitude has been shown to decline with age steadily through the fifth decade of life.

[0005] Cataracts, or the condition when the natural crystalline lens becomes opaque and clouds vision, occurs in millions of people per year and are treated effectively with surgical techniques, such as ultrasonic phacoemulsification

pioneered by Kelman about 40 years ago. Although the techniques have been refined over the years, safety concerns from ocular trauma, especially to the corneal endothelium from the ultrasonic energy required to break up a hardened cataract is undesirable, especially for those with a compromised corneal endothelium, such as those with Fuchs Dystrophy.

[0006] Several difficulties arise in the use of lasers in the treatment of cataracts. Cataracts scatter light, including laser light, and thus can prevent a laser treatment beam from having the desired effect on the tissue being treated. Moreover, the light scattering effect of cataracts and other opacifications can make determining the position and shape of the lens by optical means difficult.

[0007] The established treatment for cataracts is the removal of the opacified human crystalline lens and its replacement with an intra ocular lens (IOL). In general, IOLs consist of a small plastic lens with plastic side struts, called haptics, to hold the lens in place within the capsular bag inside the eye. Exemplary types of IOLs include monofocal lenses, multifocal IOLs, which provide the patient with multiple-focused vision at far and reading distances, and accommodative IOLs, which provide the patient with visual accommodation. The flexible nature of many IOLs enables them to be rolled and/or folded up for insertion into the capsule. Examples of IOLs are found in U.S. Patent Nos. 7,188,949, 6,849,091, 5,699,142 and 5,607,472, the entire disclosures of each of which are incorporated herein by reference. Commercially available IOLs that, by way of example, may benefit from the present invention are CRYSTALENS and ACRYSOFT RESTOR.

[0008] The CRYSTALENS IOL was developed by Eyeonics and is presently provided by Bausch & Lomb. It is at least in part believed to be disclosed in U.S. Patent No. 6,849,091. Further information regarding its structure and efficacy is provided by the Food and Drug Administration (FDA) PMA P030002 and related documents to that PMA file. The FDA approved indicated use for CRYSTALENS was in part: "The crystalens™ Model AT-45 Accommodating IOL is intended for primary implantation in the capsular bag of the eye for visual correction of aphakia in adult patients in whom a cataractous lens has been removed and is intended to provide near, intermediate, and distance vision without

spectacles. The crystalens™ IOL provides approximately one diopter of monocular accommodation.” (November 14, 2003 PMA P030002 at Part 2, Summary of Safety and Effectiveness Data, ¶ INDICATIONS FOR USE).

5 [0009] Thus, the CRYSTALENS is an example of an FDA approved accommodating IOL. The term “FDA approved accommodating IOL” refers to any IOL that has obtained FDA approval having an indicated use that provides for accommodation, regardless whether such IOL is actually being employed for such an approved use.

10 [0010] The ACRYSOF RESTOR IOL is provided by Alcon and is at least in part believed to be disclosed in U.S. Patent No. 5,669,142. Further information regarding its structure and efficacy is provided by FDA PMA P040020 and related documents to that PMA file. The FDA approved use for RESTOR was in part: “AcrySOF® ReSTOR® IOLs are indicated for the visual correction of aphakia secondary to removal of a cataractous lens in adult patients with and without
15 presbyopia, who desire near, intermediate and distance vision with increased spectacle independence. The lens is intended to be placed in the capsular bag.” (April 24, 2004, PMA P040020, at Part 2, Summary of Safety and Effectiveness Data, ¶ INDICATIONS).

20 [0011] Thus, the RESTOR is an example of an FDA approved IOL for near, intermediate and distance vision. The term “FDA approved IOL for near, intermediate and distance vision” refers to any IOL that has obtained FDA approval having an indicated use that provides for near, intermediate and distance vision, regardless of whether such IOL is actually being employed for such an approved use. The CRYSTALENS would also be an example of an FDA approved IOL for
25 near, intermediate and distance vision. Moreover, the RESTOR and CRYSTALENS are examples of an FDA approved IOLs that reduce and/or eliminate the need for spectacles.

30 [0012] A schematic representation of the shape and general structure of an example of an accommodating IOL, along the lines of a CRYSTALENS, is provided in FIG. 8. This IOL has a lens structure 202, hinges 203 located adjacent to the lens structure 202 and haptics 204, which contact the lens capsule 201. The

overall shape of this IOL would be non-geometric. As used herein the term “non-geometric shape” refers to shapes other than circles, ellipses, squares and rectangles. As used herein the term “geometric shape” refers to circles, ellipses, squares and rectangles.

5 **[0013]** The removal of the natural crystalline lens and replacement with a lens replacement material employ the use of a small initial incision or incisions in the limbal area of the eye, which is the transition area between the cornea and sclera. This initial incision is typically made with a small triangular blade that is pushed through the outer clear cornea of the eye. It is through this initial incision
10 that other instruments for use in the removal and replacement of natural lens material are inserted. It is also through this incision that the natural lens material is removed from the eye and replacement lens material is inserted into the eye.

[0014] Once the initial incision has been made the removal of the opacified natural crystalline lens and replacement with a lens replacement
15 material, such as an FDA approved IOL, presently employees a capsulorhexis and/or a capsulotomy. A capsulorhexis generally consists of the removal of a part of the anterior lens capsule and the creation of a hole or opening in the lens capsule, that results at least in part from a tearing action. A capsulotomy generally consists of a cutting of the lens capsule, without or with minimum tearing of the
20 capsule. Thus, to remove the opacified natural lens material, the lens capsule is opened. There are several known techniques for performing a capsulorhexis and a capsulotomy.

[0015] One of these capsulorhexis techniques is a can opener approach. This approach uses a small bent needle to make small incisions around the
25 anterior lens capsule to create an opening in the lens through which the lens could be removed. This technique quite often results in the opening in the lens capsule having ragged edges. Another of these techniques is a Continuous Curvilinear Capsulorhexis (CCC). CCC uses the same type of bent needle to begin the tear in the anterior lens capsule and then uses this needle and/or special forceps which
30 are guided under the edge of the cut to tear a circular hole in the lens capsule. CCC, in comparison to the can opener approach, reduces the ragged edge around

the opening in the lens that occurred with using the can opener technique.

However CCC does not eliminate the formation of irregularities in the shape of the edge and the presence of these irregularities is dependent upon surgical skill and technique.

5 **[0016]** The use of a Fugo plasma blade to create the hole in the anterior capsule may also be used. This technique is referred to as a capsulotomy. The Fugo plasma blade is a hand held device and was originally utilized in dentistry. It is an electromagnetic device that focuses its energy on a blunt cutting filament. Information regarding the Fugo plasma blade can be found in FDA PMA K063468, 10 K001498, K041019, and K050933 and US Patent No. 5413,574.

SUMMARY

[0017] The novel and improved methods and systems for the performance of incisions in the natural crystalline human lens, also at times 15 referred to herein as the lens, the natural lens, the human lens, and the crystalline lens, which include aspects of the present inventions and which are set forth in detail in the present patent specification, may provide for better implementation of other methods and systems for delivering laser beams to the lens of the eye, such as those disclosed in published applications US 2007/173794A1, US 20 2007/173795A1, US 2007/185475A1, WO 2007/084694 A2 (now US serial no. 12/217,295), and WO 2007/084627A2 (now US serial no. 12/217,285) the entire disclosure of each of which is incorporated herein by reference.

[0018] Provided herein are embodiments of the present invention. There is provided a system for providing laser shot patterns to the natural human 25 crystalline lens of an eye for softening the natural human lens, having a therapeutic laser for producing a laser beam; a laser shot pattern for performing a capsulotomy; a laser shot pattern having a first and a second area for sectioning a natural human lens of the eye, where the first area of the laser shot pattern has a different shot and/or cut density from the second area of the laser shot pattern; and 30 in this way upon delivery of the shot pattern to the lens of the eye the shots will

cause the lens to have different softness and apparent densities, which differences will correspond to the first and second areas.

5 **[0019]** Moreover, in this system the number of shots for the first area may be denser than the number of shots for the second area, the number of shots for the second area may be denser than the number of shots for first area, and the shot pattern may further have patterns for creating a number of volumetric shapes. These volumetric shapes for the first area may be denser than the number of volumetric shapes for the second area and the number of volumetric shapes for the second area may be denser than the number of
10 volumetric shapes for first area. The patterns may consist essentially of volumetric shapes such as cubes and spheres.

[0020] Moreover, in this system the pattern of shots for the first area may be denser than the pattern of shots for the second area, the pattern of shots for the second area may be denser than the pattern of shots for first area,
15 and the shot pattern may further have patterns for creating a number of volumetric shapes. These volumetric shapes for the first area may be more densely packed than the volumetric shapes for the second area and the volumetric shapes for the second area may be more densely packed than the volumetric shapes for the first area. The pattern of shots may consist
20 essentially of a plurality of volumetric shapes such as cubes and spheres.

[0021] There is also provided a method of providing laser shot patterns to the natural human crystalline lens of an eye for softening the natural human lens, having a therapeutic laser for producing a laser beam; a laser shot pattern for performing a capsulotomy; a laser shot pattern having a first and a second area for
25 sectioning a natural human lens of the eye, where the first area of the laser shot pattern has a different shot and/or cut density from the second area of the laser shot pattern; and in this way upon delivery of the shot pattern to the lens of the eye the shots will cause the lens to have different softness and apparent densities, which differences will correspond to the first and second areas.

5 **[0022]** Moreover in this method the pattern of shots for the first area may be denser than the pattern of shots for the second area, the pattern of shots for the second area may be denser than the pattern of shots for the first area, and the shot pattern may further have patterns for creating a number of volumetric shapes. These volumetric shapes for the first area may be more densely packed than the volumetric shapes for the second area and the volumetric shapes for the second area may be more densely packed than the volumetric shapes for first area. The pattern of shots may consist essentially of a series of volumetric shapes such as cubes and spheres.

10 **[0023]** Moreover in this method the number of shots for the first area may be denser than the number of shots for the second area, the number of shots for the second area may be denser than the number of shots for first area, and the shot pattern may further have patterns for creating a number of volumetric shapes. These volumetric shapes for the first area may be denser than the number of volumetric shapes for the second area and the number of volumetric shapes for the second area may be denser than the number of volumetric shapes for first area. The patterns may consist essentially of volumetric shapes such as cubes and spheres.

15 **[0024]** There is yet further provided a system and a method for providing laser shot patterns to the natural human crystalline lens of an eye for differentially softening the natural human crystalline lens, the system including: a therapeutic laser for producing a laser beam; a laser shot pattern for sectioning the natural human crystalline lens of the eye, including a first, a second and a third area; each area consisting essentially of a plurality of a volumetric shapes; at least two of the areas having different densities of the volumetric shapes; so that at least two of the areas when delivered to the natural human lens provide lens areas having different softnesses. In this system and method the shape of any one of the volumetric shapes may be in the shape of an aspiration tube or needle that is commonly used to remove lens material from the capsular bag. Further the shape of at least one of the areas

20
25
30

may be based upon, or follow in whole or in part, the shape of such an aspiration tube or needle.

5 **[0025]** There is further provided a system and method for providing a laser beam shot pattern to a natural human crystalline lens of an eye, the system including a laser for providing a laser beam, a controller having associated with it a shot pattern. This shot pattern including a pattern for providing a multiplicity of independent spheres in the lens of the eye. Thus, pursuant to this system and method the shot pattern may include a pattern for providing at least five independent spheres along an axis of the lens of the eye, 10 it may have a pattern for populating substantially the entire lens with spheres and it may comprise a pattern and sequence of delivery of the shots in the pattern that provide for the formation of a layer of bubbles at least partially surrounding a sphere. Additionally, this shot pattern may have associated therewith further patterns for performing capsulotomies.

15 **[0026]** Additionally, there is provided a method and a system for providing lubrication to lubricate natural human crystalline lens material for removal from an eye, the system and method have the following processes and components which include a laser for providing a laser beam, a controller having associated with it a shot pattern, the shot pattern having a pattern for providing a 20 multiplicity of spheres in the lens of the eye; and, the placement of the shots in the shot pattern in the lens of the eye such that bubble formation occurring during the delivery of the laser beam associates itself with the spheres and provides lubrication for the removal of the spheres.

25 **[0027]** Moreover, there is provided a system and method for providing laser shot patterns to section the natural human crystalline lens of an eye and for softening and lubricating sections of the natural human lens, the system and method including: a therapeutic laser for producing a laser beam; a laser shot pattern for performing a capsulotomy; a laser shot pattern for sectioning a natural human lens of the eye; the laser shot pattern consisting essentially of a plurality of 30 spheres; the laser shot pattern including a first area and a second area; and the

first area of the laser shot pattern having a different shot and/or cut density from the second area of the laser shot pattern so that when the area shot pattern is delivered to the natural human crystalline lens provides a lens that is softened and lubricated for more easy removal.

5 **[0028]** There is also provided a system for providing laser shot patterns to the natural human crystalline lens of an eye for differentially softening the natural human crystalline lens, the system including a therapeutic laser for producing a laser beam laser shot pattern for sectioning the natural human crystalline lens of the eye, including a first and a second pattern, the first pattern
10 consisting of a plurality of laser shots to create a plurality of radial cuts in the lens, the second pattern consisting of a plurality of laser shots to create a plurality of cylindrical cuts. Wherein the cylindrical cuts are concentrically positioned in the area of the radial cuts. Still further, the first pattern may have a plurality of laser shots to create a plurality of radial cuts in the lens, the radial cuts sharing a
15 common center point, the second pattern may have a plurality of laser shots to create a plurality of cylindrical cuts, and the cylindrical cuts may be substantially concentric and substantially sharing an common center point. Wherein the cylindrical cuts may be concentrically positioned in the area of the radial cuts and the radial common center and cylindrical common center points are substantially
20 coincident. An improvement to the above pattern of cuts is one in which radial cuts are absent in the central cylinder of the concentric series of cylindrical cuts. Such a pattern of cuts has the advantage that it eliminates the high density of laser shots from the plurality of radial cuts which otherwise would intersect at or near the center of the pattern. The elimination of the central section of radial cuts in turn
25 prevents a buildup of bubbles in the center of the pattern and improves the safety profile of the pattern by avoiding generation of a high level of radiant exposure of laser light in the central region of the cornea or retina.

[0029] Additionally there is provided a system for providing laser shot patterns to the natural human crystalline lens of an eye for differentially softening
30 the natural human crystalline lens, the system including: a therapeutic laser for producing a laser beam; a laser shot pattern for sectioning the natural human

crystalline lens of the eye, including a first and a second pattern; the first pattern having a plurality of laser shots to create a plurality of radial cuts in the lens; the second pattern having a plurality of laser shots to create a plurality of cylindrical cuts; and, wherein the cylindrical cuts are positioned in the area of the radial cuts.

5 **[0030]** Moreover there are provided systems and method for providing a laser beam shot pattern to a natural human crystalline lens of an eye, the system including having or providing a laser for providing a therapeutic laser beam; the laser having a controller associated with it, the controller having a shot pattern associated with it; the shot pattern including a pattern for providing a multiplicity of
10 substantially rods of a square or rectangular cross section in the lens of the eye; and, delivering or being capable of delivering the shot pattern to the lens of the eye. Further these provided embodiments may have shot pattern includes a pattern for providing at least 2, at least 3, at least 4 and at least 5 substantially
15 independent rods, that may further be are substantially rectangular or tubular or combinations of both. Alternatively the square or rectangular cross section tubes may be contiguous such that they form a space filling volume which occupies the central volume within the crystalline lens.

[0031] One of ordinary skill in the art will recognize, based on the teachings set forth in these specifications and drawings, that there are various
20 embodiments and implementations of these teachings to practice the present invention. Accordingly, the embodiments in this summary are not meant to limit these teachings in any way.

25 BRIEF DESCRIPTION OF THE DRAWINGS

[0032] FIG. 1 is a diagram showing a shot pattern for the sectioning and removal of lens material.

[0033] FIG. 2 is a diagram showing a shot pattern for the sectioning and removal of lens material.

30 **[0034]** FIG. 3 is a diagram showing a shot pattern for the sectioning and removal of lens material.

[0035] FIG. 4 is a cross sectional diagram showing three types of aspiration needles for removal of lens material.

[0036] FIG. 5 is a diagram showing a shot pattern for the sectioning and removal of lens material.

5 [0037] FIG. 6A and 6B are plan and cross sectional diagrams of a lens showing a multiplicity of spheres shot pattern.

[0038] FIG. 6C is a diagram of some of the spheres from the pattern of FIGS. 6A & 6B.

10 [0039] FIG. 7 is a schematic diagram of a type of system for delivering a laser beam shot pattern, such as the shot patterns of FIGS. 1-3, 5, 9 and 11-17, to the lens of an eye.

[0040] FIG. 8 is a diagram of an accommodating IOL.

[0041] FIG. 9 is a diagram showing a shot pattern positioned on the lens of the eye in relation to the accommodating IOL of FIG. 8.

15 [0042] FIGS. 10 A-D are diagrams illustrating a band cut circular capsulotomy.

[0043] FIGS 11 and 12 are illustrations of shot patterns utilizing radial and spherical patterns and combinations thereof.

[0044] FIGS 13A-C are diagrams illustrating laser shot patterns.

20 [0045] FIGS 14A-C are diagrams illustrating laser shot patterns.

[0046] FIGS 15A and B are diagrams illustrating laser shot patterns.

[0047] FIGS 16A and B are diagrams illustrating laser shot patterns.

[0048] FIGS 17A and B are diagrams illustrating laser shot patterns.

25

DESCRIPTION OF THE PREFERRED EMBODIMENTS

[0049] In general, the present inventions relate to methods and systems for providing a laser to the lens of the eye to address and improve procedures relating to the removal of the natural crystalline lens and replacement of that lens with lens replacement material, and more specifically to improvements in systems and methods related to cataract surgery. In particular, the present inventions

30

relate to methods and systems for providing predetermined laser shot patterns to the natural crystalline lens of the eye, which shots patterns have different densities of shots and cuts. These shot patterns when delivered to the lens effecting a softening of the lens material making it easier to remove from the lens capsule.

5 Thus, the present invention provides the ability to customize and predetermine the relative amounts of force that are needed to remove specific sections of the lens material during cataract surgery.

[0050] The present methods and systems can be used with the novel and innovative laser system techniques that are the subject of the co-pending

10 patent applications that are cited herein and which have been incorporated herein by reference, and the present methods and systems may possibly be used with other laser delivery systems for the removal of lens material to the extent such systems may be developed in the future. Preferably, the present methods and systems can be incorporated into and used in conjunction with the systems of the

15 co-pending applications that have been incorporated herein by reference. In this way a single system, with a single therapeutic laser, can function as a start to finish device for performing the cuts necessary to remove and replace the natural lens.

[0051] Novel and pioneering laser systems and methods for the removal and replace of lens material are disclosed in U.S. provisional and regular patent

20 applications: serial number 61/228,506, System and Method for Performing a Jigsaw Capsulotomy (attorney docket number 12212/44); serial number 61/228,484, System and Method for Performing and Sealing Limbal Area Incisions in the Eye (attorney docket number 12212/48, Title of Application); serial number 61/228,514, System and Method for Performing Corrective Arcuate Incisions in the

25 Eye (attorney docket number 12212/49, Title of Application); serial number 12/509,412, Method and System for Removal and Replacement of Lens Material from the Lens of an Eye (attorney docket number 12212/51); and, serial number 12/509,211, Method and System for Creating a Bubble Shield for Laser Lens Procedures (attorney docket number 12212/54), which were filed on July 24, 2009,

30 and the entire contents of each of which are incorporated herein by reference.

[0052] Thus, there is provided a system and method for the structural modification of the lens to make it easier to remove while potentially increasing the safety of the procedure by reducing and/or eliminating the need to use high frequency ultrasonic energy used in phaco emulsification. In general, the use of photodisruption cutting in specific volumetric shape patterns is utilized to create a sectioned lens, i.e., to carve up the lens into sectioned volumetric shapes. Moreover, the size, shape and distribution of these volumetric shapes can be placed in the lens of the eye in such a way as to create areas of varying density, apparent density, or softness, which areas may have different and predetermined shapes.

[0053] As used herein when the lens is referred to as becoming softer, or softening, when lens material is becoming easier to remove from the lens capsule and thus will require less force and effort to be removed. Thus, as disclosed herein the lens becomes softer after it has interacted with a laser using a given shot density, and/or a given cut density. Thus, as used herein softness increases for the region of treatment as the cut density increases. Similarly, as softness increases, the amount of force and effort to remove the lens decreases. In general, if the similar shape cuts and patterns are being used, patterns with a greater density of shots and patterns with a greater number of cuts will result in lens that has greater increases in softness and requires less force and effort to be removed.

[0054] The shapes of these areas can be varied to coincide with the shape of the tip of the aspiration needles that are used to remove the lens material from the capsule, either with or without phaco emulsification. Typically, these needles have tips which have a 47°, 30° or a 0° edge. These tips are illustrated in FIG. 4 as tip 47, 30 and 0 respectively.

[0055] A shot pattern for providing areas of varying density is provided in FIG. 1. Thus, there is shown a plan view schematic of a natural human lens and thereon is provided a lens having a lens capsule 1 and an area of hydrodissection 2. There is further provided, by way of example, three areas of varying shot density, a first area 3, a second area 4 and a third area 5.

[0056] There is provided a first area of varying shot and/or cut density 3. This area of varying density is formed by cutting the lens into volumetric shapes such as cubes, spheres as provided in greater detail in this specification, cones, rods, etc. The density of these volumetric shapes (as well as the laser shots and cuts used to form them) in this first area is low.

[0057] There is provided a second area of varying shot and/or cut density 4. This area of varying density is formed by cutting the lens into volumetric shapes such as cubes, spheres as provided in greater detail in this specification, cones, rods, etc. The volumetric shapes of this second area may be the same as or they may be different from the volumetric shapes of the first area. The density of these volumetric shapes (as well as the laser shots and cuts used to form them) in the second area 4 is greater than the density of volumetric shapes in the first area 3.

[0058] There is provided a third area of varying shot and/or cut density 5. This area of varying density is formed by cutting the lens into volumetric shapes such as cubes, spheres as provided in greater detail in this specification, cones, rods, etc. The volumetric shapes of this third area may be the same as or they may be different from the volumetric shapes of the first area or the volumetric shapes of the second area. The density of these volumetric shapes (as well as the laser shots and cuts used to form them) in the third area 5 is greater than the density of volumetric shapes in the second area 4.

[0059] Thus, in Figure 1 there is provided three shot patterns having varying shot and cut density, when applied to the lens of an eye these shot patterns will result in three areas of lens, having corresponding shapes and having varying softness as described above.

[0060] A shot pattern for providing areas of varying shot and/or cut density is provided in FIG. 2. Thus, there is shown a plan view schematic of a natural human lens and thereon is provided a lens having a lens capsule 6 and an area of hydrodissection 7. There is further provided, by way of example, three areas of varying shot density, a first area 8, a second area 9 and a third area 10.

5 **[0061]** There is provided a first area of varying shot and/or cut density 8. This area of varying density is formed by cutting the lens into volumetric shapes such as cubes, spheres as provided in greater detail in this specification, cones, rods, etc. The density of these volumetric shapes (as well as the laser shots and cuts used to form them) in this first area is low.

10 **[0062]** There is provided a second area of varying shot and/or cut density 9. This area of varying density is formed by cutting the lens into volumetric shapes such as cubes, spheres as provided in greater detail in this specification, cones, rods, etc. The volumetric shapes of this second area may be the same as or they may be different from the volumetric shapes of the first area 8. The density of these volumetric shapes (as well as the laser shots and cuts used to form them) in the second area 9 is greater than the density of volumetric shapes in the first area 10.

15 **[0063]** There is provided a third area of varying density 10. This area of varying density is formed by cutting the lens into volumetric shapes such as cubes, spheres as provided in greater detail in this specification, cones, rods, etc. The volumetric shapes of this third area may be the same as or they may be different from the volumetric shapes of the first area or the volumetric shapes of the second area. The density of these volumetric shapes (as well as the laser shots and cuts used to form them) in the third area 10 is greater than the density of volumetric shapes in the second area 9. Thus, the apparent density of the lens in this third area 10 will be lower than the apparent density of lens in the second area 9, and in turn, the apparent density of the lens in the second area 9 will be lower than the apparent density of lens in the first area 8, which in turn is lower than the apparent density in the lens before sectioning.

20 **[0064]** As used herein when referring to the apparent density of sectioned lens in an area varying density; lower apparent density lens areas correspond to softer and more easily aspirated material, while higher apparent density lens areas correspond to firmer and more difficult to aspirate material. As used herein when referring to areas of varying density, the use of the term first, second, and third are relative terms with respect to density of a particular pattern

and do not refer to the sequence of order in which those patterns are placed on the lens. Moreover, as used herein the term area refers to and includes 3-dimensional, i.e., volumetric, shapes.

5 **[0065]** A shot pattern for providing areas of varying shot and/or cut density is provided in FIG. 3. Thus, there is shown a plan view schematic of a natural human lens and thereon is provided a lens having a lens capsule 11 and an area of hydrodissection 12. There is further provided, by way of example, two areas of varying shot density, a first area 13 and a second area 14.

10 **[0066]** There is provided a first area of varying shot and/or cut density 13. This area of varying density is formed by cutting the lens into volumetric shapes such as cubes, spheres as provided in greater detail in this specification, cones, rods, etc. The density of these volumetric shapes (as well as the laser shots and cuts used to form them) in this first area is low.

15 **[0067]** There is provided a second area of varying shot and/or cut density 14. This area of varying shot and/or cut density is formed by cutting the lens into volumetric shapes such as cubes, spheres as provided in greater detail in this specification, cones, rods, etc. The volumetric shapes of this second area may be the same as or they may be different from the volumetric shapes of the first area. The density of these volumetric shapes (as well as the laser shots and cuts
20 used to form them) in the second area 14 is greater than the density of volumetric shapes in the first area 13.

25 **[0068]** There is provided in FIG. 5 a shot pattern for providing areas of varying shot and/or cut density in which the shape of the area of highest shot and/or cut density is in the shape of and thus corresponds to the shape of a 47° aspiration tube. Thus, there is shown a plan view schematic of a natural human lens and thereon is provided a lens having a lens capsule 16 and an area of hydrodissection 16. There is further provided, by way of example, two areas of varying shot density, a first area 17 and a second area 18.

30 **[0069]** There is provided a first area of varying shot and/or cut density 17. This area of varying density is formed by cutting the lens into volumetric shapes such as cubes, spheres as provided in greater detail in this specification,

cones, rods, etc. The density of these volumetric shapes (as well as the laser shots and cuts used to form them) in this first area is low.

5 **[0070]** There is provided a second area of varying shot and/or cut density 18. This area of varying density is formed by cutting the lens into volumetric shapes such as cubes, spheres as provided in greater detail in this specification, cones, rods, etc. The shape of this area of varying density corresponds to the shape of a 47° aspiration tube or needle, i.e., FIG. 4 tube shape 47. The volumetric shapes of this second area may be the same as or they may be different from the volumetric shapes of the first area. The density of these
10 volumetric shapes (as well as the laser shots and cuts used to form them) in the second area 18 is greater than the density of volumetric shapes in the first area 17. Thus, the lens where the second shot pattern is applied will be softer than the lens in the first area. In this way there is created by the application of these two patterns an area of softened lens that provides for the easier, safer and less
15 traumatic initial insertion of the aspiration tube or needle. Accordingly, by first aspirating the material from area 18, a surgeon can then insert the aspiration tip into area 17 to hold and/or gain better access to area 17 and further help propagate the manipulation of the lens for removal.

20 **[0071]** While the second area 18 is illustrated in FIG. 5 as corresponds to the shape of a 47° aspiration tube 47 (of FIG. 4) it should be understood that this shape could also correspond to the other shapes of aspiration tubes currently used, for example the current shape of aspiration tubes are shown in FIG. 4 (in which shape 47 illustrates the shape of a 47° aspiration tube, shape 30 illustrates the shape of a 30° aspiration tube shape 0 illustrates the shape of a 0° aspiration
25 tube), or shapes developed in the future.

30 **[0072]** A shot pattern is provided in FIGS. 6A and 6B. FIG. 6A is a plan view of the lens of an eye having a multiplicity of spheres shot pattern thereon and FIG. 6B is a cross sectional view of the same lens having the same multiplicity of spheres pattern thereon. FIGS. 6A and 6B by way of example and without limitation illustrate a pattern where when applied to the lens will cut the lens so that substantially all of the lens has been populated with independent spheres.

Although not shown a hydrodissection may be used with this shot pattern. There is provided a lens capsule 21 and a multiplicity of spherical laser shot patterns 22, which has a plurality of individual sphere patterns 23, (only a few of the spheres 23 are numbered, i.e., 23a, 23b, 23c, 23d, and 23e, to avoid making the figure
5 confusing) which sphere patterns do not touch and are separated by lens material.

[0073] In this particular embodiment the spheres are of a size that provides for the placement of six spheres along the y axis of the lens. The size of the spheres may vary provided that space is left between them and that a sufficient number of spheres are cut into the lens to soften the lens for extraction.

[0074] The creation of these spheres in the lens of the eye will cause the formation of bubbles. These bubbles will be associated with the spheres and it is theorized that they may be present around the sphere, i.e., on the surface of the sphere. These bubbles will serve as lubrication for the movement of the spheres into the aspiration needle for removal. The bubble layer is provided by way of
10 illustration in FIG. 6C. Thus, there are shown spheres 23a, 23b, and 23c, from the plurality of spheres in FIGS. 6A & 6B. These spheres each have bubble layers, 24a, 24b and 24c associated respective with them. These bubble layers can be made up of individual bubbles that have not coalesced, bubbles that have
15 coalesced into a film, and combinations thereof.

[0075] The sequence of laser shots in the patterns herein may be executed from posterior to anterior, as in most of the patterns disclosed herein, to obtain more predictable results by reducing the variation caused by shooting through gas bubbles. However, it may be desirable to shoot cataracts from the anterior to the posterior for the purpose of choosing the lesser of two undesirable
20 effects. Thus, it may be advantageous to shoot through the gas bubbles, or let them dissipate, rather than shooting through cataractous tissue, which much more severely scatters the light and more quickly prevents photodisruption compared to gas bubble interference. Accordingly, it is proposed to photodisrupt the most
25 anterior sections of the cataract first, then move posteriorly, shooting through gas bubble remnants of cataractous tissue, to the next layer of cataract tissue below.
30 In addition to shooting the laser in anterior z planes then moving posterior, it is

further provided to essentially drill down anterior to posterior, which is called herein the z axis and then move in x/y and drill down again. These shot patterns may also be applied to a clear lens and that lens is subsequently removed. It is desirable when dealing with a clear lens that shooting from posterior to anterior is
5 utilized.

[0076] In general a preferred laser system, *i.e.*, a laser device, for treating patients is provided as shown by way of example in FIG. 7. In this system there is provided a treatment laser 101; optics 102 for delivering the laser beam 104; a control system 103 for delivering the laser beam to the lens in a particular
10 pattern 103, which control system 103 is associated with and/or interfaces with the other components of the system, as shown for example by dashed lines in FIG. 7, and/or other control systems not shown in FIG. 7.

[0077] In general, a laser system for providing the softening of the natural crystalline lens by generating laser incisions in the lens has by way of
15 example and referring to FIG. 7 a treatment laser 101 which should provide a beam 104 that is of a wavelength that transmits through the cornea, aqueous and lens. The beam should be of a short pulse width, together with the energy and beam size, to produce photodisruption. Thus, as used herein, the term laser shot or shot refers to a laser beam pulse delivered to a location that results in
20 photodisruption. As used herein, the term photodisruption essentially refers to the creation of a microscopic shock wave at laser beam focus and conversion of matter to a gas by the laser. The term photodisruption has also been generally associated with Laser Induced Optical Breakdown (LIOB). In particular, wavelengths of about 300 nm to 2500 nm may be employed. Pulse widths from
25 about 1 femtosecond to 100 picoseconds may be employed. Energies from about a 1 nanojoule to 1 millijoule may be employed. The pulse rate (also referred to as pulse repetition frequency (PRF) and pulses per second measured in Hertz) may be from about 1 KHz to several GHz. Generally, lower pulse rates correspond to higher pulse energy in commercial laser devices. A wide variety of laser types
30 may be used to cause photodisruption of ocular tissues, dependent upon pulse width and energy density. Thus, examples of such lasers are disclosed in

2007/084694 A2 and WO 2007/084627A2 (now US serial no. 12/217,285), the entire contents of each of which are incorporated herein by reference. These and other similar lasers may be used as therapeutic lasers.

5 [0078] In general, the optics for delivering 102 the laser beam 104 to the structures of the eye including the natural lens of the eye should be capable of providing a series of shots to the natural lens in a precise and predetermined pattern in the x, y and z dimensions. The z dimension as used herein refers to that dimension which has an axis that corresponds to, or is essentially parallel with the optical (AP) axis of the eye. The optics should also provide a predetermined beam
10 spot size to cause photodisruption with the laser energy reaching the natural lens, or other structure of the eye intended to be cut.

[0079] In general, the control system 103 for delivering the laser beam 104 may be any computer, controller, and/or software hardware combination that is capable of selecting and controlling x-y-z scanning parameters and laser firing.
15 These components may typically be associated at least in part with circuit boards that interface to the x-y scanner, the z focusing device and/or the laser. The control system may also, but does not necessarily, have the further capabilities of controlling the other components of the system, as well as, maintaining data, obtaining data and performing calculations. Thus, the control system may contain
20 the programs that direct the laser through one or more laser shot patterns. Similarly, the control system may be capable of processing data from the biometric slit scanned laser and/or from a separate controller for the slit scanned laser system. The slit scanned laser system is a system used to measure the position of optical surfaces within the eye, such as the anterior and posterior lens and corneal
25 surfaces or other eye features such as crystalline lens cataracts. Such measurements are used by the control system to generate patterns of laser shots to perform the desired crystalline lens incisions.

[0080] The laser optics for delivering 102 the laser beam 104 comprise a beam expander telescope 105, a z focus mechanism 106, a beam combiner 107,
30 an x-y scanner 108, and focusing optics 109. There is further provided relay optics 110, camera optics 111, which include a zoom, and a first ccd camera 112.

[0081] Optical images 113 of the eye 114 and in particular optical images of the natural lens 115 of the eye 114 are conveyed along a path 113. This path 113 follows the same path as the laser beam 104 from the natural lens 115 through the laser patient interface 116, the focusing optics 109, the x-y scanner 108 and the beam combiner 107. There is further provided a laser patient interface 116, and a structured light source 117 and a structured light camera 118, including a lens. Examples of patient interface and related apparatus that are useful with the present system are provided in U.S. applications serial number 12/509,021, Liquid Filled Index Matching Device for Ophthalmic Laser Procedures, (attorney number 12212/53), serial number 61/228,457, Liquid Holding Interface Device for Ophthalmic Laser Procedures (attorney number 12212/47), filed July, 24, 2009, serial number 12/840,818, Liquid Holding Interface Device for Ophthalmic Laser Procedures (attorney number 12212/70), filed July, 21, 2010 the entire disclosure of each of which is incorporated herein by reference.

[0082] A structured light source 117 may be a slit illumination having focusing and structured light projection optics, such as a Schafter+Kirchhoff Laser Macro Line Generator Model 13LTM+90CM, (Type 13LTM-250S-41 + 90CM-M60-780-5-Y03-C-6) or a StockerYale Model SNF-501L-660-20-5, which is also referred to as a slit scanned laser. In this embodiment the structured illumination source 117 also includes slit scanning means 119.

[0083] When using a scanned slit illumination the operation includes positioning the slit on one side of the lens, taking an image then moving the slit approximately one slit width, then taking another image, and then repeating this sequence until the entire lens is observed. For example, a 100 μm slit width can scan a nominal 9 mm dilated pupil diameter in 90 images, which takes approximately 3 seconds using a 30 Hz frame rate camera. To obtain images of the anterior surface in a single image without overlap, the slit should be at an angle to the axis of the structured light camera 118, i.e., it should not be parallel to that axis. The nominal slit angle can be approximately 30-60 degrees from the structured light camera axis. Any visible or near IR wavelength source within the

sensitivity of the camera may be used. Low coherence length sources are preferable to reduce speckle noise in the structured camera image.

[0084] The structured light illumination source 117 and the structured light camera 118 are arranged in an angled relationship. The angled relationship, which may include angling the detector of the structure light camera with respect to the axis of the camera optics may be but is not required to be in the so-called Scheimpflug configuration, which is well-known. The structured light source 117, in conjunction with the slit scanning means 119, projects a line and or a plurality of lines onto the cornea and crystalline lens 115 at an angle or plurality of angles. The light scattered from these objects is focused by the lens 115 onto the camera system 118. Since the slit illuminated image of the cornea and lens 115 is at a large angle with respect to the camera 118, this presents a large depth of field to the camera and the entire slit image may not be in sharp focus at the camera. By tilting the camera at an angle or plurality of angles the image along the illuminated plane can be in sharper focus. To the extent that a sharper focus is not obtained, arithmetic data evaluation means are further provided herein to determine a more precise location of the illuminated structures with respect to the laser device.

[0085] Alternatively, the structured light illumination source may be a focused beam whose point of focus is scanned throughout the regions of interest within the eye. The scanned path of the beam might simulate the area illuminated by the scanned slit illumination described above by executing a raster scan of a plane of the eye analogous to that illuminated by the slit laser. In this context, raster scan refers to a process in which the beam focus is scanned, row by row, to illuminate a section of the eye. In this case, the camera's detector would be exposed to the scattered light from the scanned beam for the whole duration of the raster scan.

[0086] The images from the camera 118 may be conveyed to the controller 103 for processing and further use in the operation of the system. They may also be sent to a separate processor and/or controller, which in turn communicates with the controller 103. The structured light source 117, the camera 118 and the slit scanning means 119 includes a means for determining the position

crystalline lens and corneal surfaces in relation to the laser system and thus includes a means for determining the position and apex of the lens in relation to the laser system.

5 **[0087]** The delivery of laser shot patterns for the removal of lens is provided. Thus, there are provided methods and systems for producing cuts, *i.e.*, incisions in the anterior lens capsule. These cuts are created by the therapeutic laser beam 104 being delivered to the anterior lens capsule in precise predetermined and highly reproducible patterns, delivery results in precise predetermined and highly reproducible shaped cuts in patterns as described and
10 taught herein, or as may be called for by the use of a particular IOL or other device or material to be inserted within the lens capsule. As used herein geometric shaped patterns or cuts refer to circular and elliptical shaped patterns or cuts. As used herein non-geometric shaped patterns or cuts refers to all other shapes that are not circular or elliptical.

15 **[0088]** The methods and systems to create these cuts in the anterior capsule provide superior results to the handheld methods and apparatus previously known for performing capsulorhexus and capsulotomy, and thus, the methods and systems disclosed herein are considered to be a substantial advancement in these techniques. In addition the delivery of the laser beam shots
20 in a manner that greatly reduces the risk of a missed cut, which depending upon the particular application may be very significant is provided. Moreover, anterior capsule cuts are envisioned and provided that may be a continuous cuts, cuts and lands (uncut capsule portions between cuts) and perforations. Thus, as used herein the terms "missed cut" or "missed cuts" refer to a cut that was intended to
25 be carried out by the delivery of a particular laser shot pattern, but which did not occur because the laser beam missed the lens capsule or targeted lens material or the targeted material was hit but not cut. Thus, in a cut and land pattern the lands would not be considered missed cuts, if they were intended to be left uncut by the laser pattern.

30 **[0089]** The cuts in the lens anterior surface are for the purpose of creating an opening in the lens capsule for the remove of the interior structures of

the lens. To facilitate this removal there are provided various laser shot patterns that cut the interior structure of the lens into small volumes, which volumes can then be removed from the lens capsule. These small volumes can range from about 0.1 mm³ to about 30 mm³ and more preferably from about 0.4 mm³ to about 1 mm³. Thus a grid laser shot pattern within the interior structures of the lens, which creates cube shaped volumes of interior lens material, can be employed. These cubes can range in size from a side having a length of about 100 μm to about 3 mm, to about 4mm, with about 500 μm to 2 mm being a preferred size. An ideal size for the volumetric shapes is one in which the dimensions of the volumetric shape roughly match the size of the opening at the distal end of the aspiration tube. This enables the individual volumetric shape pieces to be easily aspirated into the aspiration tube without or with minimal use of ultrasound energy. Volumetric shape pieces that are substantially smaller than the opening in the aspiration tube require more laser shots without added significant benefit. Additionally, this invention is not limited to the formation of cubes and other volumetric shapes of similar general size may be employed. For example, in addition to the spheres that are provided herein and illustrated in FIGS. 6A – 6C, arrangement of other shapes such as triangles and pie sliced volumes may be employed.

[0090] The laser cut in the anterior capsule is used to create a small opening in the lens anterior surface of the lens capsule for removal of the sectioned volumes of interior material. Thus, this procedure may be used to treat cataracts. This procedure may also be used to remove a lens having opacification that has not progressed to the point of being cataractous. This procedure may further be used to remove a natural lens that is clear, but which has lost its ability to accommodate. In all of the above scenarios, it being understood that upon removal of the lens the lens capsule would subsequently house a suitable replacement, such as an IOL, accommodative IOL, or synthetic lens refilling materials. Moreover, the size and the shape of the opening is variable and precisely controlled and preferably for presently known lens refilling materials and

IOLs is 2 mm or less diameter for lens refilling applications and about 5 mm for IOLs.

5 [0091] The creation of capsulotomy for the surgeon to access the lens to remove the lens is illustrated in FIGS. 10 A-D. In these figures there is provided an outer surface 801, which surface is formed by the lens capsule, and thus an outer shape of the lens. There is further provided a ring shaped band cut 802 and shot pattern. This shot pattern is provided by placing the laser beam in a series of tightly placed shots around the ring at the deepest depth (most posterior ring) and then continuing that sequence as the depth of the ring is decreased. Thus, in 10 general the shot will be distributed entirely around the ring at a particular depth before moving to a shallower depth. Thus, the figure shows the cross section view of this cylindrical incision and accordingly provides for two sides 802 of the ring. The ring shaped capsulotomy cuts of 100 μm deep, approximately centered on the apex as determined by the above referenced method of the anterior lens capsule surface and precisely 5mm in diameter. The diameter of the capsulotomy can be 15 varied between about 0.1mm to about 9mm diameter.

[0092] Since the lens capsule is approximately 5 to 15 μm thick, it is desirable for the depth of the cut to be typically between 5 and several hundred 20 μm , although there is not much penalty for cutting several millimeters. With greater precision regarding the location and shape of the lens and lens apex the thickness of the band and in particular the amount of the band that is above the lens capsule and in the aqueous can be reduced. The shape of the capsulotomy can be elliptical with the x-axis different then the y-axis or other shapes. Thus, the shape of the capsulotomy can be any shape that provides a benefit for a particular IOL, 25 for example the shape of the capsulotomy can be circular, elliptical, square, rectangular, or a non-geometric shape. The shape will be based at least in part upon and be determined at least in part by, the aspects of IOLs and in particular accommodating IOLs and IOLs that reduce and/or eliminate the need for spectacles. A particular IOL, such as FDA approved IOLs discussed herein, may 30 benefit from and/or may require a particular capsulotomy shape and opening smoothness.

[0093] FIG. 9 illustrates a precise predetermined non-geometric cut that *can* be created by implementing the predetermined shot pattern in relation to the type of IOL shown in FIG. 8. Thus, there is provided an IOL lens structure 502, hinges 503 located adjacent to the lens structure 502, and haptics 504, which
5 contact the lens capsule 501. There is further provided a precise predetermined non-geometric capsulotomy 505, having two non-linear, i.e., curved sections and two essentially linear, i.e., straight sections. The positioning of these sections is further illustrated in FIG. 9, with the essentially straight sections being positioned inside of the hinges, i.e., so that the remaining lens capsule covers at least in part
10 the haptics, and with the curved section being inside of the lens structure 502, i.e. the remaining lens capsule covers the outer edge of the lens structure 502. This type of capsulotomy is referred to as an ALL-ON. This cut and pattern would be an example of a cut, opening, capsulotomy and pattern that essentially follow the shape of an IOL.

[0094] The order in which these activities are performed may depend upon the particular characteristics of the internal lens structure, the density of the cataract, the position of the cataract, the type of device used to remove the internal lens material once it has been sectioned into small volumes, the type and power of the laser used, the amount and size of gas bubbles that are produced by the laser,
20 and other factors. Thus, although the examples herein provide for an order of performing the activity of cutting the anterior surface of the lens and sectioning the interior structures of the lens, it should be recognized that this order can be changed, as well as, performed essentially simultaneously or simultaneously.

[0095] The preferred laser system for treating patients is capable of
25 making precise and predetermined cuts in the capsule of the lens thus giving rise to capsulotomies that are of precise and predetermined shapes. Thus, there is provided the method of obtaining and analyzing the shape and structure of an IOL, and in particular obtaining and analyzing the shape and structure of an accommodating IOL, an IOL that reduces and/or eliminates the need for
30 spectacles, and/or an IOL for near, intermediate and distance vision, including but limited to FDA approved versions of said IOLs. Based upon this analysis an

5 optimized shape and position for the capsulotomy for use with a particular IOL, or grouping of similarly shaped IOLs, is determined. A predetermined shot pattern for making this optimized shaped capsulotomy is then provided to the laser system, preferably by providing the shot pattern to the control system 103. The laser system can then be used for an one or all of the following procedures, determining the shape and position of the anterior surface of the lens, and in particular the anterior surface of the lens capsule, determining the apex of the lens capsule in relation to the laser system, performing a laser capsulotomy having the precise and predetermined shape selected for a particular type of IOL, and removal of the natural lens material.

10 [0096] Thus, there is provided techniques, systems and apparatus to deliver a laser beam in a shot pattern to the lens of the eye and in particular to the capsule of the lens of the eye in a precise and predetermined manner to provided for a precise predetermined capsulotomy. The shape of these patterns may be delivered using either the jigsaw or ring delivery sequences.

15 [0097] When performing laser assisted cataract surgery the process of cutting the nucleus with a photodisruption laser can cause a buildup of gas bubbles sufficiently near the soft cortex to allow the gas bubbles to propagate toward the capsule. In those situations where bubbles collect in close proximity to the anterior capsule, when the laser attempts to cut the capsulotomy, the sudden release of bubbles may change the position of the anterior capsule during the delivery of the laser shot pattern causing the laser to miss the capsule resulting in missed cuts, at least partially around the circumference of the capsulotomy. To solve this problem, there is provided herein a special cutting pattern that is less dependent of capsule position versus time and provides cutting of the capsule despite position changes of the capsule during the laser capsulotomy procedure. Thus, resulting in substantially reduced or no missed cuts.

20 [0098] There is further provided herein the use of laser shot patterns having a large range of Z swept at a high rate of speed, while the X-Y position is moved in a circular, or elliptical or other pattern or desired shape, more slowly so that the laser cutting action occurs multiple times over essentially the same X-Y

position. Thus, it could be envisioned that the laser beam is operating like the tip of a jigsaw blade moving up and down rapidly compared to the X-Y positioning to create the cut shape. In this way, if the anterior capsule shifts during the cut, due to gas bubble propagation or any other reason, the cut will still be made to the capsule, albeit perhaps outside the center region of the z direction up-down distribution of shots, and more to the anterior or posterior ends of that distribution. For laser cutting of the nucleus where a great deal of bubble buildup is created, a Z range, or up-down range of the cut should be approximately 1mm in extent, nominally centered on the anterior capsule which would allow approximately +/- 475 μm of capsule movement and still provide cutting of a 25 μm thick capsule.

[0099] In addition to enabling cutting of a capsule that moves during the procedure, this procedure can be used to compensate for static errors in capsule position due to for example measurement errors. In this way the extent of the Z range may be increased by the known error of the system.

[00100] In addition to the large Z range sweeps disclosed herein, there is also contemplated the use of a smaller Z range of cut motion for the case where the uncertainty in capsule position from both static measurement error and anticipated change in position might be smaller, perhaps in the range of hundreds of μm or in the case of highly precise measurement data and near zero movement of the capsule during surgery. In such a case the Z range could be tens of μm -- enough range to cut through the capsule thickness.

[00101] The Z range sweep in the capsulotomy shot pattern provides for the ability to optimize laser surgery efficiency in cataract removal procedures. Thus, the nucleus of the lens can be sectioned into small volumes before the capsulotomy is performed. In this way any gas bubbles that are formed by the sectioning of the nucleus will be trapped within the capsule. By keeping the gas bubbles inside of the capsule, their effect on laser delivery is reduced, when compared to their effect if they escape from the capsule and migrate into the aqueous or collect and build up next to the posterior of the cornea. The detrimental effect of shooting the laser beam through a bubble increases as the distance that the beam has to travel after passing through the bubble before

reaching its intended point increases. Thus, by trapping the bubble in the capsule this distance is kept to an absolute minimum and thus the detrimental effect of shooting through the bubbles is similarly minimized.

5 **[00102]** The accumulation of bubbles within the capsule, however, increases the likelihood that the lens and/or capsule will shift during the capsulotomy as the bubbles escape through the cuts in the lens capsule. As noted above this shifting could result in missed cuts and an incomplete capsulotomy. Thus, the Z range sweep avoids any missed cuts from lens or capsule movement and accordingly provides the synergistic advantages of increased laser efficiency, reduced detrimental effect of gas bubbles, and reduced missed cuts in the
10 capsulotomy.

[00103] Thus there is provided a system and method to optimize laser surgery efficiency in an embodiment of the invention by allowing the nucleus to be cut first, and the gas bubbles formed from such cutting contained within the
15 capsule, until the capsulotomy is performed. The containing of the gas bubbles within the capsule avoids having to shoot through bubbles in the anterior chamber caused but creating the capsulotomy first. This solution, however, can lead to the accumulation of bubbles inside the fibrous mass of the lens which may cause the capsule to move during capsulotomy. To address this potential movement the
20 invention further provides for the varying z direction movement of the laser beam. However, it is also understood that, one case where the uncertainty of capsule movement is small is the case where the capsulotomy is laser cut prior to the cutting of the nucleus material and no bubbles have been placed in the lens. In this case if the uncertainty in position is sufficiently small that the extent of the z
25 range is sufficiently small, so that only a superficial amount of bubbles may be present in the anterior chamber which may not interfere with laser cutting of the nucleus. It should further be understood that when referring to a sequence of cutting structures, such as described in this paragraph, that the sequence is met when a substantial majority of the cuts are performed in the one structure before
30 another structure, i.e., the placement of a few laser shots in another structures

during delivery of the shot pattern to the first structure will not prevent the first structure from being considered the first structure in the sequence.

5 **[00104]** Further methods and systems to define a high accuracy position measurement of structures of the eye and in particular the anterior capsule, so as to provide in general greater accuracy, precisions and reproducibility from patient to patient for procedures on the eye and in particular capsulotomies, is provided in application serial number 12/509,412 (Method and System for Removal and Replacement of Lens Material from the Lens of an Eye) filed on July 24, 2009 and having attorney number 12212/51, the entire disclosure of which is incorporated
10 herein by reference.

[00105] A further optimization of the method and system to enhance flexibility regarding the aspiration of lens material from the lens capsule is provided. In sectioning the lens material it is possible that some of the cut
15 fragments of the fibrous mass may escape the capsular bag, either by floating or because of gas bubbles or just naturally, unless means of preventing such escape are provided. Therefore another aspect of the present method and system is to provide a means to restrain these fragments until they are ready to be aspirated out. Such a means is provided by performing only a partial cut of the capsule,
20 leaving the capsule flap attached to serve as a restraint, preventing and/or reducing the escape of sectioned lens material. Once aspiration is called for the partial cut to the capsule can be completed, i.e., the capsulotomy is completed, and the sectioned lens material aspirated out of the lens capsule.

[00106] In the laser shot patterns provided herein it is preferred that the laser shot patterns generally follow the shape of the lens and placement of
25 individual shots with respect to adjacent shots in the pattern are sufficiently close enough to each other, such that when the pattern is complete a sufficiently continuous layer and/or line and/or volume of lens material has been removed. Shot spacing of lesser or greater distances are contemplated herein and including overlap as necessary to obtain the desired results. Shot spacing considerations
30 include gas bubble dissipation, volume removal efficiency, sequencing efficiency, scanner performance, and cleaving efficiency among others. For example, by way

of illustration, for a $5\ \mu\text{m}$ size spot with an energy sufficient to cause photodisruption, a spacing of $20\ \mu\text{m}$ or greater results in individual gas bubbles, which are not coalesced and dissipate more quickly, than with close shot spaces with the same energy, which result in gas bubble coalescence. As the shot spacing gets closer together volume efficiency increases. As shot spacing gets closer together bubble coalescence also increases. Further, there comes a point where the shot spacing becomes so close that volume efficiency dramatically decreases. For example, by way of illustration, for a 450 femtosecond pulse width and 2 microjoules energy and about a $5\ \mu\text{m}$ spot size with a $10\ \mu\text{m}$ separation results in cleaving of transparent ocular tissue. As used herein, the term cleaving means to substantially separate the tissue. Moreover, the forgoing shot spacing considerations are interrelated to a lesser or greater extent and one of skill in the art will know how to evaluate these conditions based upon the teachings of the present disclosure to accomplish the objectives herein. Finally, it is contemplated that the placement of individual shots with respect to adjacent shots in the pattern may in general be such that they are as close as possible, typically limited by the size and time frame of photodisruption physics, which would include among other things gas bubble expansion of the previous shot. As used herein, the time frame of photodisruptive physics refers to the effects that take place surrounding photodisruption, such as plasma formation and expansion, shock wave propagation, and gas bubble expansion and contraction. Thus, the timing of sequential pulses such that they are timed faster than some of, elements of, or all of those effects, can increase volumetric removal and/or cleaving efficiency. Accordingly, we propose using pulse repetition frequencies from 50 MHz to 5 GHz, which could be accomplished by a laser with the following parameters: a mode lock laser of cavity length from 3 meters to 3 cm. Such high PRF lasers can more easily produce multiple pulses overlapping a location allowing for a lower energy per pulse to achieve photodisruption.

[00107] The terms first, second, third, etc. as used herein are relative terms and must be viewed in the context in which they are used. They do not relate to timing, unless specifically referred to as such. Thus, a first cut may be

made after a second cut. In general, it is preferred to fire laser shots in general from posterior points in the laser pattern to anterior points, to avoid and/or minimize the effect of the gas bubbles resulting from prior laser shots. However, because of the varied laser shot patterns that are provided herein, it is not a requirement that a strict posterior to anterior shot sequence be followed. Moreover, in the case of cataracts it may be advantageous to shoot from anterior to posterior, because of the inability of the laser to penetrate substantially beyond the cataract.

[00108] In FIG. 11 there is shown the lens 1108 as seen as if looking through the pupil edge 1107 of the iris 1105. In this figure there is provided two regions of shots and/or cuts. There is provided a central region 1101 having a high cut density pattern, for example of small spheres, e.g., 1102, of 0.25 to 0.75 mm in diameter. This figure also has an outer region 1103 with radial cuts 1104(a)-1104(h). These cuts act as a pre-cut to the lens material in the vicinity of the iris 1105. In this way the pre-cut radials may tend to propagate out to the equator with some external applied force. This external force may be a mechanical manipulator or hand held instrument or it may be through the insertion of BSS or other safe liquid to cause the pre-cuts to propagate out to the equator.

[00109] In FIG. 12 there is shown the lens 1208 as seen as if looking through the pupil edge 1207 of the iris 1205. In this figure there is shown a similar pattern to FIG. 11, except the radial cuts 1204(a) - 1204(h) extend through the center of the lens and are done first by the laser to assure the cutting attributes are not interfered with by any high density cuts for example spheres, e.g., 1202. It is presently preferred and believed to be advantageous to assure that the radial cuts are complete and then to make the smaller cuts like spheres in between the radial cuts. The net effect of either the patterns of 11 or 12 is to have a control region where aspiration can more easily be accomplished as a peripheral region where radial cuts may have the opportunity to be extended to the equator by the application of external force.

[00110] In FIGS. 13A and 13B there are shown a side cross-section and a top cross section of a lens, respectively, having the same laser shot pattern. FIG.

13C provides a prospective, relief, view of the same lens and shot pattern. Thus, there is shown the lens capsule 1301. There is shown a series of elliptical radial cuts 1302(a) to 1302(f), a series of other differently shaped radial cuts 1304 (only one of these cuts has been numbered for clarity). These radial cuts to a certain extent can be envisioned as is cuts made in slicing a pie. There is further shown a series of cylindrical cuts 1306(a) to 1306(d). There is shown a capsulotomy cut 1308.

[00111] In FIGS. 14A and 14B there are shown a side cross-section and a top cross section of a lens, respectively, having the same laser shot pattern. FIG. 14C provides a prospective, relief, view of the same lens and shot pattern. Thus, there is shown the lens capsule 1401. There is shown a series of elliptical radial cuts 1402(a) to 1402(f), a series of spherical cuts 1404 (only one of these cuts has been numbered for clarity). There is shown a capsulotomy cut 1408.

[00112] In FIGS. 15A and 15B there are shown a top cross section and a side cross-section of a lens, respectively, having the same laser shot pattern 1508. There is shown the lens capsule 1501. There is shown a laser shot pattern or cut pattern 1508 having a grid pattern of vertical 1504 and horizontal 1506 cuts (as viewed in the drawing of the figure). This shot pattern results in the lens being sectioned into a series of elongated rectangular rods. The shape of these rods can be sized to match, or be slightly smaller than the size of the opening of the aspiration tube used to remove the sectioned lens material. Thus, the size of the rectangles in the grid pattern is based upon the opening size of the aspiration tube, which presently ranges from about 0.4 mm to 1 mm. The ability to match the size of the rectangles in the grid pattern, and thus the size of the rectangular sections of lens material created by delivery of the shot pattern to the lens, to the size of the opening in the aspiration tube enhances the ability to safely and efficiently extract the lens material during lens replacement procedures.

[00113] In FIGS. 16A and 16B there are shown a top cross section and a side cross-section of a lens, respectively, having the same laser shot pattern 1608. There is shown the lens capsule 1601. There is shown a laser shot pattern or cut pattern 1608 having a grid pattern of vertical 1604 and horizontal 1606 cuts (as

viewed in the drawing of the figure). This shot pattern results in the lens being sectioned into a series of elongated rectangular rods. The shape of these rods can be sized to match, or be slightly smaller than the size of the opening of the aspiration tube used to remove the sectioned lens material. Thus, the size of the rectangles in the grid pattern is based upon the opening size of the aspiration tube, which presently ranges from about 0.4 mm to 1 mm. The ability to match the size of the rectangles in the grid pattern, and thus the size of the rectangular sections of lens material created by delivery of the shot pattern to the lens, to the size of the opening in the aspiration tube enhances the ability to safely and efficiently extract the lens material during lens replacement procedures. In this figure there is further shown that the shape of the sectioned materials follow the shape of the anterior capsule of the lens.

[00114] In FIGS. 17A and 17B there are shown a top cross section and a side cross-section of a lens, respectively, having the same laser shot pattern 1708. There is shown the lens capsule 1701. There is shown a laser shot pattern or cut pattern 1708 having a grid like pattern of circular 1704 cuts that form a series of tube like shapes 1705. This shot pattern results in the lens being sectioned into a series of elongated tubular rods. The shape of these rods can be sized to match, or be slightly smaller than the size of the opening of the aspiration tube used to remove the sectioned lens material. Thus, the size of the rectangles in the grid pattern is based upon the opening size of the aspiration tube, which presently ranges from about 0.4 mm to 1 mm. The ability to match the size of the rectangles in the grid pattern, and thus the size of the rectangular sections of lens material created by delivery of the shot pattern to the lens, to the size of the opening in the aspiration tube enhances the ability to safely and efficiently extract the lens material during lens replacement procedures. In this figure there is further shown that the shape of the sectioned materials follow the shape of the anterior capsule of the lens.

[00115] From the foregoing description, one skilled in the art can readily ascertain the essential characteristics of this invention, and without departing from

the spirit and scope thereof, can make various changes and/or modifications of the invention to adapt it to various usages and conditions.

5 **[00116]** Accordingly, the invention may be embodied in other forms than those specifically disclosed herein without departing from its spirit or essential characteristics. The described embodiments are to be considered in all respects only as illustrative and not restrictive, and the scope of the invention is commensurate with the appended claims rather than the foregoing description.

What is claimed:

1. A system for providing laser shot patterns to a natural human lens of an eye for softening the natural human lens, the system comprising:
 - a. a therapeutic laser for producing a laser beam;
 - 5 b. a laser shot pattern for sectioning a natural human lens of the eye, comprising a first and a second area;
 - c. the first area of the laser shot pattern having a different shot and/or cut density from the second area of the laser shot pattern; and,
 - 10 d. wherein the laser shot patterns of the first and second areas when delivered to the natural human lens provide a lens having areas of different softness.
2. The system of claim 1 wherein a number of shots for the first area is denser than a number of shots for the second area.
3. The system of claim 1 wherein a number of cuts for the second area is denser
15 than a number of cuts for the first area.
4. The system of claim 1 wherein the laser shot pattern comprises patterns for creating volumetric shapes.
5. The system of claim 4 wherein a number of volumetric shapes for the first area is denser than a number of volumetric shapes for the second area.
- 20 6. The system of claim 4 wherein a number of volumetric shapes for the second area is denser than a number of volumetric shapes for first area.
7. The system of claim 1 wherein the laser shot pattern of the first area consists essentially of sectioned volumetric shapes.
8. The system of claim 7 wherein the volumetric shapes consist essentially of
25 cubes.
9. The system of claim 7 wherein the volumetric shapes consist essentially of tubes.

10. The system of claim 7 wherein the volumetric shapes consist essentially of spheres.
11. The system of claim 7 wherein the volumetric shapes comprise tubes.
12. A system for providing laser shot patterns to a natural human crystalline lens of an eye for differentially softening the natural human crystalline lens, the system comprising:
- 5
- a. a therapeutic laser for producing a laser beam;
 - b. a laser shot pattern for sectioning the natural human crystalline lens of the eye, comprising a first area, a second area and a third area;
 - 10 c. each of the first, second and third areas consisting essentially of a plurality of a volumetric shapes;
 - d. at least two of the first, second and third areas having different densities of the volumetric shapes; and,
 - e. wherein at least two of the first, second and third areas when delivered
15 to the natural human lens provide lens material having different softness.
13. The system of claim 12 wherein the system comprises a shot pattern for performing a capsulotomy.
14. The system of claim 13 wherein at least one of the first, second and third areas
20 is shaped substantially similarly to a shape of an aspiration tube.
15. The system of claim 12 wherein a shape of the first area is based upon an aspiration tube.
16. The system of claim 12 wherein a shot and/or cut density for the first area is greater than a shot and/or cut density for the second area and the shot and/or
25 cut density for the second area is greater than the shot and/or cut density for the third area.

17. A system for providing laser shot patterns to the natural human crystalline lens of an eye for differentially softening the natural human crystalline lens material, the system comprising:
- a. a therapeutic laser for producing a laser beam;
 - 5 b. a laser shot pattern for sectioning the natural human crystalline lens of the eye, comprising a first area, a second area and a third area;
 - c. at least two of the first, second and third areas having different shot densities; and,
 - 10 d. wherein at least two of the first, second and third areas when delivered to the natural human crystalline lens provide lens material having different softness.
18. The system of claim 17 wherein at least one of the first, second and third areas is shaped substantially similarly to a shape of an aspiration tube.
19. The system of claim 17 wherein a shape of the first area is based upon an
15 aspiration tube.
20. The system of claim 17 wherein the system comprises a shot pattern for performing a capsulotomy.
21. A system for providing a laser beam shot pattern to the natural human crystalline lens of an eye, the system comprising:
- 20 a. a laser for providing a laser beam;
 - b. a controller having associated with it a shot pattern; and,
 - c. the shot pattern comprising a pattern for providing a first area and a second area of varying shot and/or cut density to a natural human crystalline lens of an eye;
 - 25 d. the first area corresponding to an aspiration needle used for removal of lens material; and,

- e. wherein the first area provides for safer and easier initial aspiration of lens material from the eye.
22. The system of claim 21 wherein the controller has associated with it a capsulotomy shot pattern.
- 5 23. A system for providing a laser beam shot pattern to a natural human crystalline lens of an eye, the system comprising:
- a. a laser for providing a laser beam;
 - b. a controller having associated with it a shot pattern; and,
 - c. the shot pattern comprising a pattern for providing a multiplicity of
10 independent spheres in a natural human crystalline lens of an eye.
24. The system of claim 23 wherein the shot pattern comprises a pattern for providing at least 5 independent spheres along an axis of the natural human crystalline lens of the eye.
25. The system of claim 23 wherein the shot pattern comprises a pattern for
15 populating substantially the entire natural human crystalline lens with spheres.
26. The system of claim 23 wherein the shot pattern comprises a pattern and sequence of delivery of the shots in the pattern that provide for the formation of a layer of bubbles at least partially surrounding a sphere.
27. The system of claim 23 wherein the shot pattern comprises a pattern for
20 performing a capsulotomy.
28. The system of claim 23 wherein the shot pattern comprises a pattern and a sequence of delivery of the shots in the shot pattern that provide for the formation of bubbles around at least one of the spheres.
29. A system for providing lubrication to lubricate natural human crystalline lens
25 material for removal of such material from an eye, the system comprising:
- a. a laser for providing a laser beam;

- b. a controller having associated with it a shot pattern;
 - c. the shot pattern comprising a pattern for providing a multiplicity of spheres in a lens of the eye; and,
 - d. the placement of the shots in the shot pattern in the lens of the eye such that bubble formation occurring during delivery of the laser beam associates itself with the spheres and provides lubrication for the removal of the spheres.
- 5
30. A system for providing laser shot patterns to section a natural human crystalline lens of an eye for softening and lubricating sections of natural human lens material, the system comprising:
- 10
- a. a therapeutic laser for producing a laser beam;
 - b. a laser shot pattern for performing a capsulotomy;
 - c. a laser shot pattern for sectioning a natural crystalline human lens of an eye;
 - d. the laser shot pattern consisting essentially of a plurality of spheres;
 - e. the laser shot pattern comprising a first area and a second area;
 - f. the first area of the laser shot pattern having a different shot and/or cut density from the second area of the laser shot pattern; and,
 - g. wherein the either the laser shot pattern of the first area or the laser shot pattern of the second area when delivered to the natural human crystalline lens provides lens material that is softened and lubricated for more easy removal.
- 15
- 20
31. A method for providing laser shot patterns to the natural human lens of an eye for softening natural human lens material, the method comprising:
- 25
- a. providing a laser shot pattern for performing a capsulotomy to the anterior capsule of a natural human lens of an eye;

- b. providing a laser shot pattern for sectioning the natural human lens of the eye, the shot pattern comprising a first area and a second area;
 - c. the first area of the laser shot pattern having a different shot and/or cut density from the second area of the laser shot pattern; and,
 - 5 d. creating different areas of apparent density in the lens of the eye corresponding to the first and second areas.
32. The method of claim 31 wherein a number of shots for the first area is denser than a number of shots for the second area.
33. The method of claim 31 wherein a number of shots for the second area is
10 denser than a number of shots for the first area.
34. The method of claim 31 wherein the shot pattern comprises patterns for creating volumetric shapes.
35. The method of claim 34 wherein a number of volumetric shapes for the first area is denser than a number of volumetric shapes for the second area.
- 15 36. The method of claim 34 wherein a number of volumetric shapes for the second area is denser than a number of volumetric shapes for the first area.
37. The method claim 31 wherein the shot pattern of the first area consists essentially of sectioned volumetric shapes.
38. The method of claim 31 wherein the volumetric shapes consist essentially of
20 spheres.
39. A method for differentially softening a natural human lens of an eye to assist in the removal and replacement of the natural human lens, the method comprising:
- a. delivering a laser shot pattern to a natural human lens of an eye for sectioning the natural human lens, the pattern comprising a first area, a
25 second area and a third area;
 - b. each of the first, second and third areas consisting essentially of a plurality of volumetric shapes;

- c. at least two of the first, second and third areas having different densities of the volumetric shapes; and,
 - d. creating areas of differentially softened lens material, the areas of differentially softened lens material corresponding to the at least two of the first, second and third areas having different densities of volumetric shapes.
- 5
40. The method of claim 39 wherein the method comprises delivering a laser shot pattern for performing a capsulotomy.
41. The method of claim 39 wherein at least one of the first, second and third areas is shaped substantially similarly to a shape of an aspiration tube.
- 10
42. The system of claim 39 wherein a shape of the first area is based upon an aspiration tube.
43. The method of claim 39 wherein a shot and/or cut density for the first area is greater than a shot and/or cut density for the second area and the shot and/or cut density for the second area is greater than a shot and/or cut density for the third area.
- 15
44. A method for providing laser shot patterns to a natural human crystalline lens of an eye for differentially softening a natural human lens material, the method comprising:
- 20
- a. providing a therapeutic laser for producing a laser beam;
 - b. delivering a laser shot pattern for sectioning a natural human crystalline lens of the eye, the shot pattern comprising a first area, a second area and a third area;
 - c. at least two of the first, second and third areas having different shot densities; and,
- 25

- d. creating corresponding areas in the lens of the eye having different apparent densities corresponding to the at least two of the first, second and third areas of different shot density.
45. The method of claim 44 wherein at least one of the corresponding areas is
5 shaped substantially similarly to a shape of an aspiration tube.
46. A method for providing a laser beam shot pattern to an eye for safer and easier initial aspiration of lens material from the eye, the method comprising:
- a. providing a laser for providing a laser beam, the laser having a controller, the controller having associated with it a shot pattern;
 - 10 b. the shot pattern comprising a pattern for providing a first area and a second area of varying shot density;
 - c. delivering the shot pattern to a lens of an eye so that: the first area is created and corresponds to an aspiration needle used for removal of the lens material and the second area is created.
- 15 47. The system of claim 46 wherein in the controller has associated with it a capsulotomy shot pattern.
48. A method for providing a laser beam shot pattern to a natural human crystalline lens of an eye, the system comprising:
- a. providing a laser for providing a laser beam;
 - 20 b. the laser having a controller having associated with it, the controller having a shot pattern associated with it;
 - c. the shot pattern comprising a pattern for providing a multiplicity of independent spheres in a lens of an eye; and,
 - d. delivering the shot pattern to the lens of the eye.
- 25 49. The method of claim 48 wherein the shot pattern comprises a pattern for providing at least 5 independent spheres along an axis of the lens of the eye.

50. The method of claim 48 wherein the shot pattern comprises a pattern for populating substantial the entire lens with spheres.
51. The method of claim 48 wherein the shot pattern comprises a pattern and sequence of delivery of the shots in the pattern that provide for the formation of a layer of bubbles at least partially surrounding a sphere.
52. The system of claim 48 wherein the shot pattern comprises a pattern and sequence of delivery of the shots in the pattern that provide for the formation of bubbles around at least one of the spheres.
53. A method for sectioning a natural human crystalline lens of an eye into a plurality of independent spheres for removal of the natural human crystalline lens, the method comprising:
- a. delivering a laser beam to a natural human crystalline lens of an eye in a shot pattern comprising a plurality of independent spheres;
 - b. sectioning the natural human crystalline lens of the eye into a plurality of independent spheres corresponding to the shot pattern; and,
 - c. removing sectioned lens material from the eye.
54. A method for providing lubrication to lubricate natural human crystalline lens material for removal of such material from an eye, the method comprising:
- a. delivering a laser beam to the natural human crystalline lens of the eye in a shot pattern, the shot pattern comprising a pattern of shots in a multiplicity of spheres;
 - b. placing the shots in the shot pattern in the natural human crystalline lens of the eye to spheres of lens material, to form bubbles associated with the spheres, and to provide lubrication for the removal of the spheres; and,
 - c. removing the spheres of lens material.

55. A method for providing laser shot patterns to section a natural human crystalline lens of an eye for softening and lubricating sections of the natural human crystalline lens material, the method comprising:

- a. providing a therapeutic laser for producing a laser beam;
- 5 b. providing a laser shot pattern for performing a capsulotomy;
- c. providing a laser shot pattern for sectioning a natural human crystalline lens of the eye;
 - i. the laser shot pattern consisting essentially of a plurality of spheres;
 - 10 ii. the laser shot pattern comprising a first area and a second area;
 - iii. the first area of the laser shot pattern having a different shot and/or cut density from the second area of the laser shot pattern; and,
- d. creating softened and lubricated areas in the natural human crystalline lens of the eye for more easy removal.
- 15

56.A system for providing laser shot patterns to a natural human crystalline lens of an eye for softening the natural human crystalline lens, the system comprising:

- a. a therapeutic laser for producing a laser beam;
- b. a laser shot pattern for performing a capsulotomy;
- 20 c. a laser shot pattern for sectioning a natural human crystalline lens of an eye, comprising a first area and a second area;
- d. the first area of the laser shot pattern having a different shot and/or cut density from the second area of the laser shot pattern; and,
- e. wherein the shot patterns of the first and second areas when delivered
- 25 to the natural human crystalline lens provide a lens having areas of different softness.

57. A system for providing laser shot patterns to a natural human crystalline lens of an eye for differentially softening the natural human crystalline lens, the system comprising:

- a. a therapeutic laser for producing a laser beam;
- 5 b. a laser shot pattern for sectioning a natural human crystalline lens of an eye, comprising a first pattern and a second pattern;
- c. the first pattern consisting of a plurality of laser shots to create a plurality of radial cuts in the natural human crystalline lens;
- d. the second pattern consisting of a plurality of laser shots to create a
10 plurality of cylindrical cuts; and,
- e. wherein the cylindrical cuts are concentrically position in an area of the radial cuts.

58. A system for providing laser shot patterns to a natural human crystalline lens of an eye for differentially softening the natural human crystalline lens, the system
15 comprising:

- a. a therapeutic laser for producing a laser beam;
- b. a laser shot pattern for sectioning a natural human crystalline lens of an eye, comprising a first pattern and a second pattern;
- c. the first pattern consisting of a plurality of laser shots to create a
20 plurality of radial cuts in the natural human lens, the radial cuts sharing a common center point;
- d. the second pattern consisting of a plurality of laser shots to create a plurality of cylindrical cuts, the cylindrical cuts being substantially concentric and substantially sharing a second common center point;
25 and,

- e. wherein the cylindrical cuts are concentrically positioned in an area of the radial cuts and the first and second common center points are substantially coincident.

59. A system for providing laser shot patterns to a natural human crystalline lens of an eye for differentially softening the natural human crystalline lens, the system comprising:

- a. a therapeutic laser for producing a laser beam;
- b. a laser shot pattern for sectioning a natural human crystalline lens of an eye, comprising a first pattern and a second pattern;
- 10 c. the first pattern consisting essentially of a plurality of laser shots to create a plurality of radial cuts in the natural human crystalline lens;
- d. the second pattern consisting essentially of a plurality of laser shots to create a plurality of cylindrical cuts; and,
- e. wherein the cylindrical cuts are positioned in an area of the radial cuts.

15 60. A method for providing a laser beam shot pattern to a natural human crystalline lens of an eye, the system comprising:

- a. providing a laser for providing a therapeutic laser beam;
- b. the laser having a controller associated with it, the controller having a shot pattern associated with it;
- 20 c. the shot pattern comprising a pattern for providing a multiplicity of substantially rectangular rods in a natural human crystalline lens of an eye; and,
- d. delivering the shot pattern to the natural human crystalline lens of the eye.

25 61. The method of claim 60, wherein the shot pattern comprises a pattern for providing at least 5 substantially independent rods.

62. A method for providing a laser beam shot pattern to a natural human crystalline lens of an eye, the system comprising:

- a. providing a laser for providing a therapeutic laser beam;
- 5 b. the laser having a controller associated with it, the controller having a shot pattern associated with it;
- c. the shot pattern comprising a pattern for providing a multiplicity of substantially tubular rods in a natural human crystalline lens of an eye; and,
- 10 d. delivering the shot pattern to the natural human crystalline lens of the eye.

63. The method of claim 62, wherein the shot pattern comprises a pattern for providing at least 5 substantially independent rods.

64. A method for providing a laser beam shot pattern to a natural human crystalline lens of an eye, the system comprising:

- 15 a. providing a laser for providing a therapeutic laser beam;
- b. the laser having a controller associated with it, the controller having a shot pattern associated with it;
- c. the shot pattern comprising a first laser shot pattern and a second laser shot pattern;
- 20 d. the first laser shot pattern comprising a plurality of laser shots to create a plurality of radial cuts; and,
- e. delivering the shot pattern to a natural human crystalline lens of an eye.

65. The method of claim 64, wherein the second shot pattern comprises a plurality of laser shots to create a cylindrical cut

- 25 66. The method of claim 64, wherein the second shot pattern comprises a plurality of laser shots to create a spherical cut.

67. A system for providing laser shot patterns to a natural human crystalline lens of an eye for differentially softening the natural human crystalline lens, the system comprising:

- a. a therapeutic laser for producing a laser beam;
- 5 b. a laser shot pattern for sectioning a natural human crystalline lens of an eye, comprising a first pattern and a second pattern;
- c. the first pattern consisting of a plurality of laser shots to create a plurality of cylindrical cuts, the plurality of cylindrical cuts being substantially concentric and substantially sharing a common center
10 point; and,
- d. the second pattern consisting of a plurality of laser shots to create a plurality of radial cuts in the natural human lens, the radial cuts sharing the common center point, wherein the plurality of radial cuts are absent in an area circumscribed by one of the plurality of cylindrical cuts that is
15 nearest the common center point.

1/14

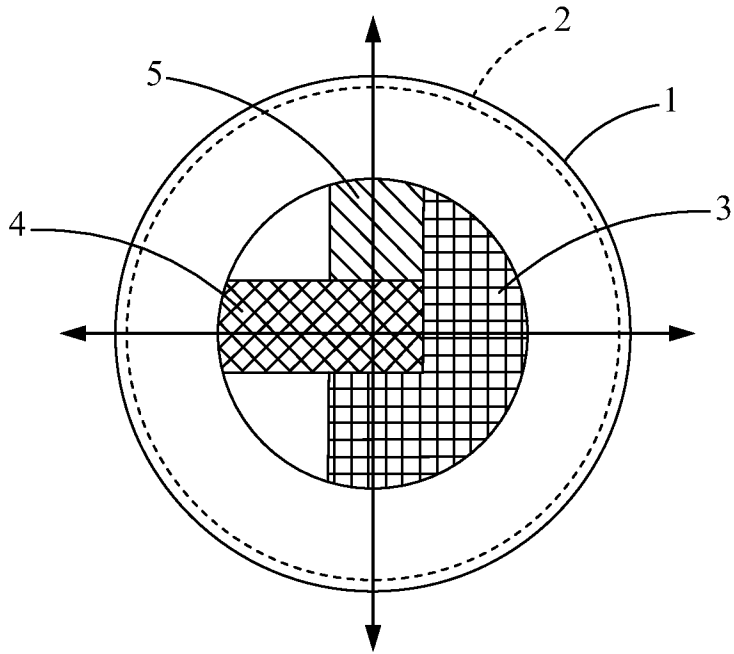

Fig. 1

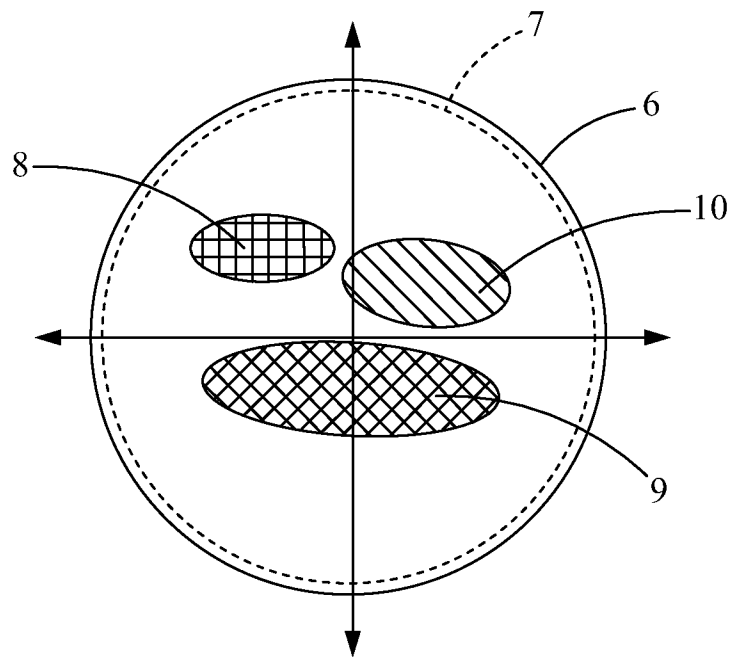

Fig. 2

2/14

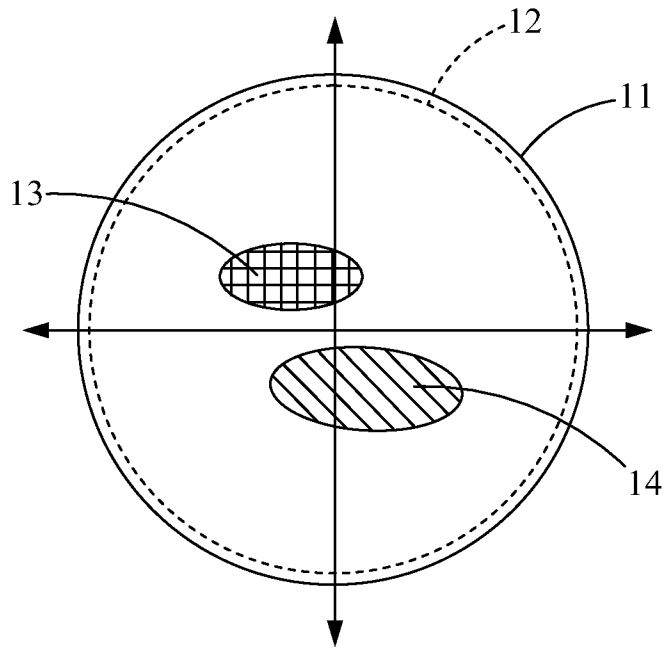

Fig. 3

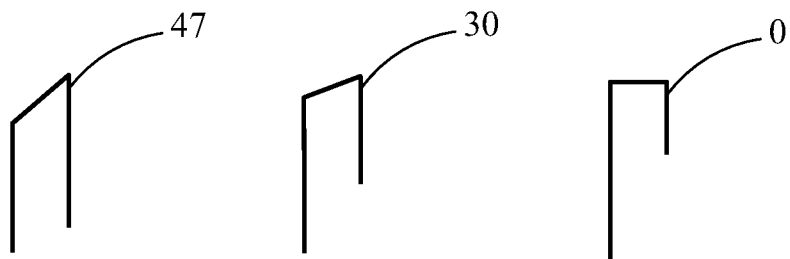

Fig. 4

3/14

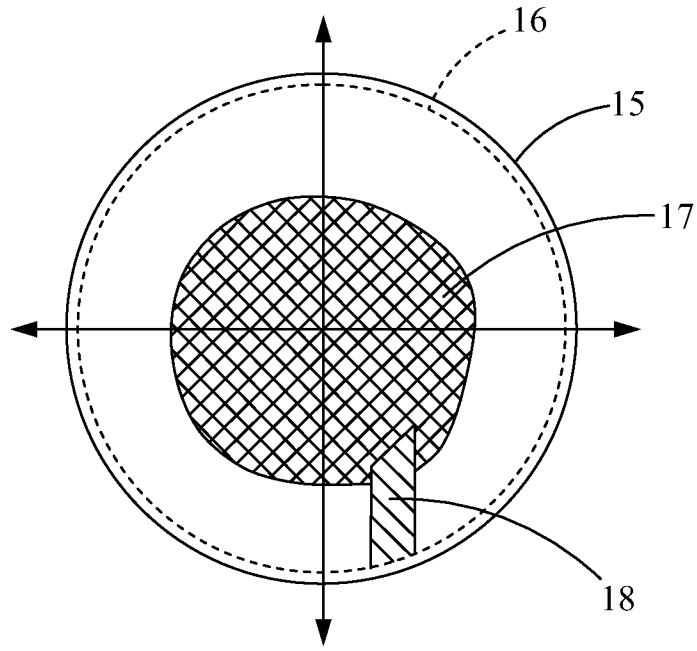

Fig. 5

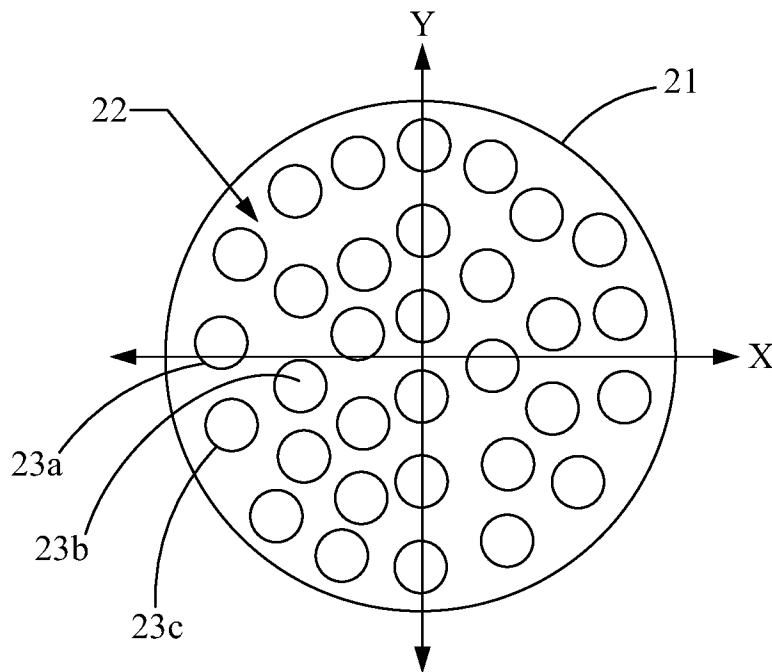

Fig. 6A

4/14

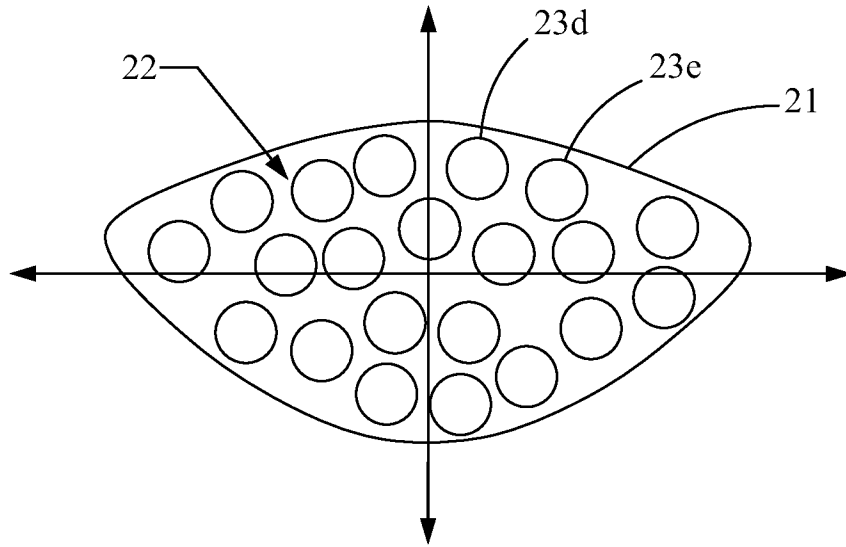

Fig. 6B

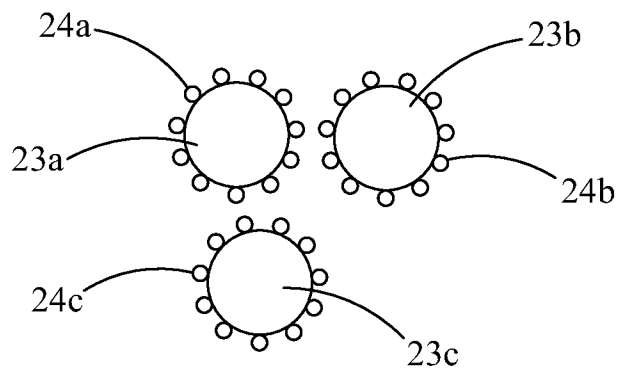

Fig. 6C

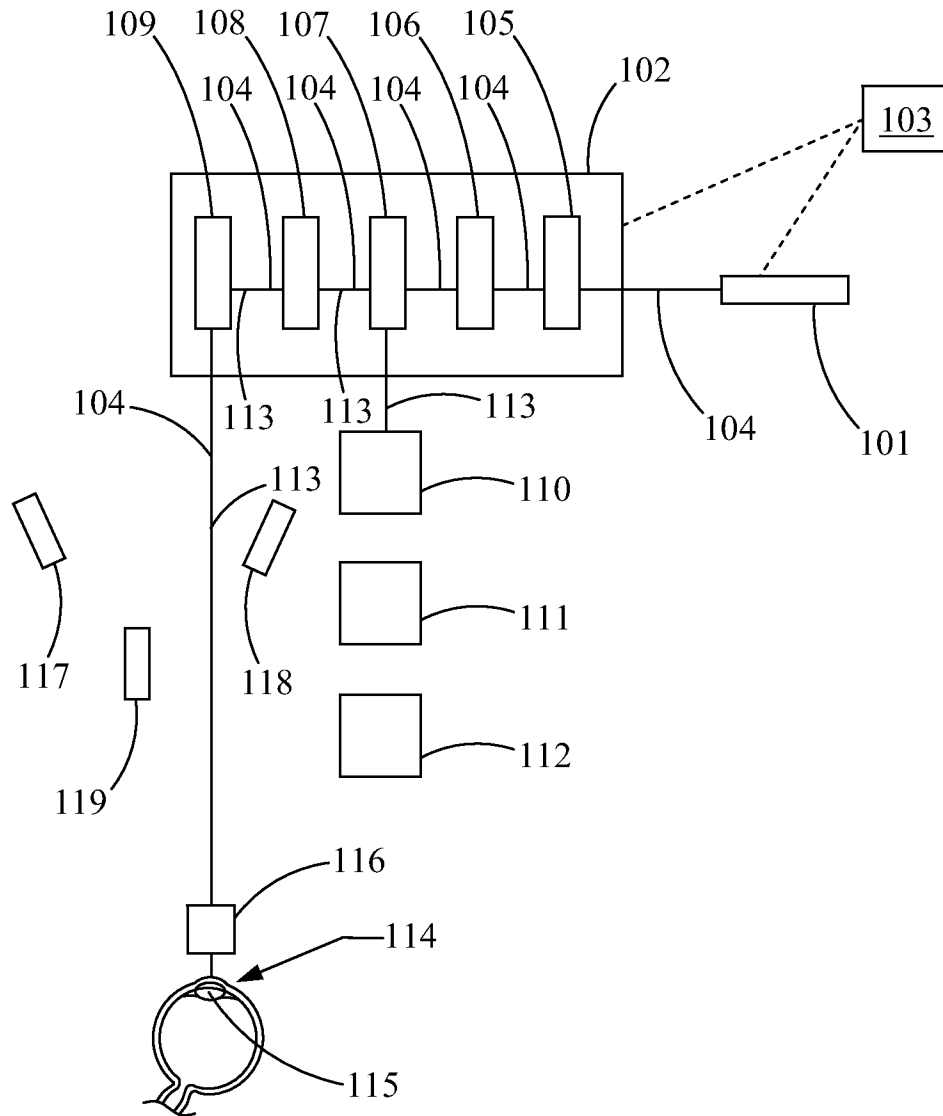

Fig. 7

6/14

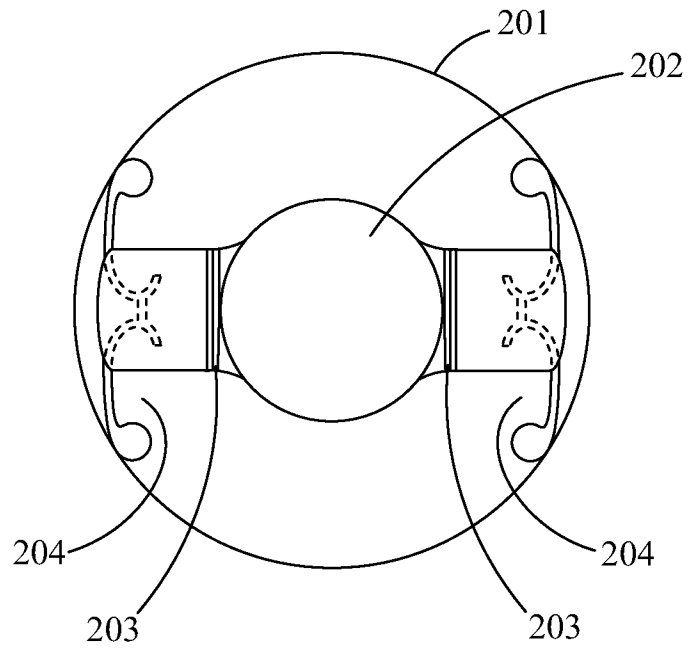

Fig. 8

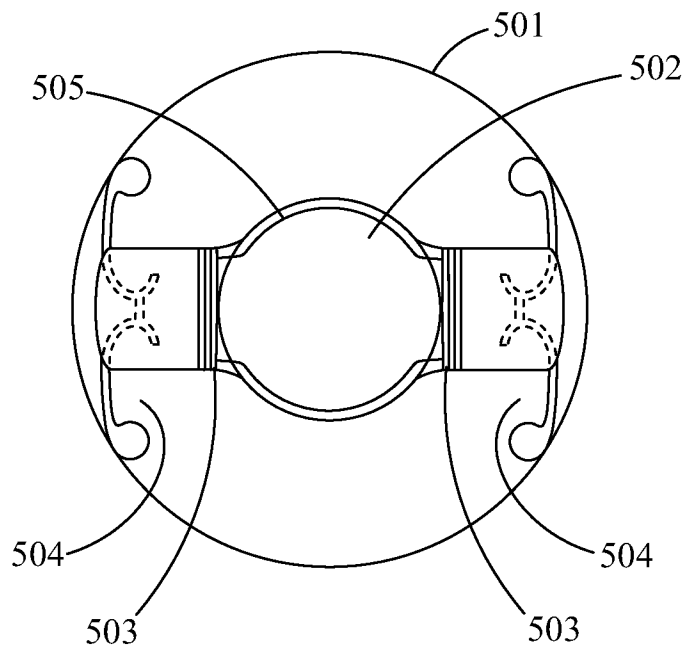

Fig. 9

7/14

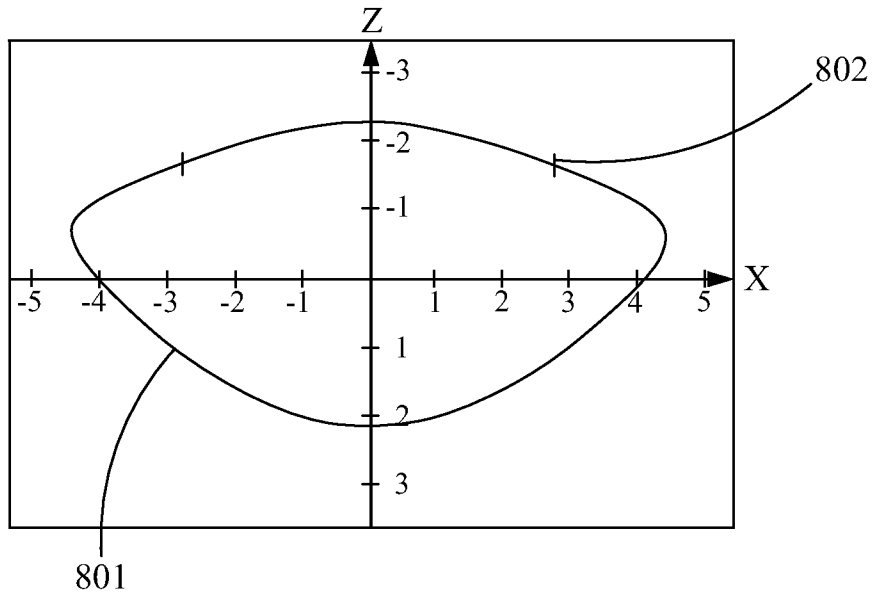

Fig. 10A

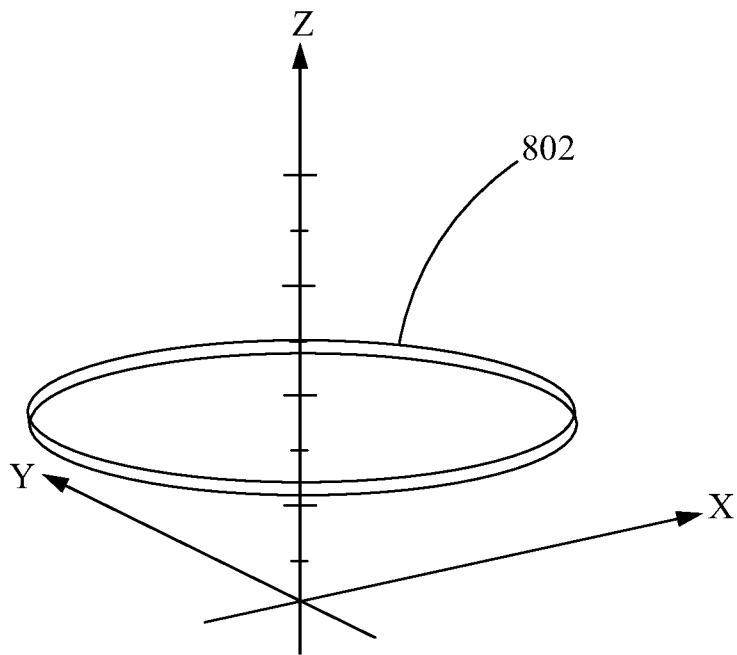

Fig. 10B

8/14

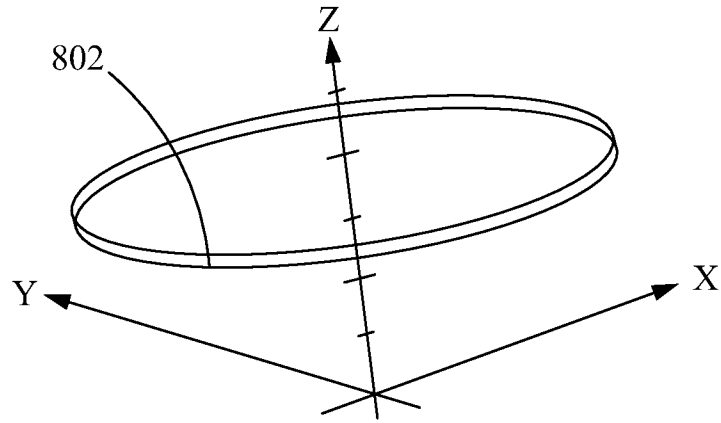

Fig. 10C

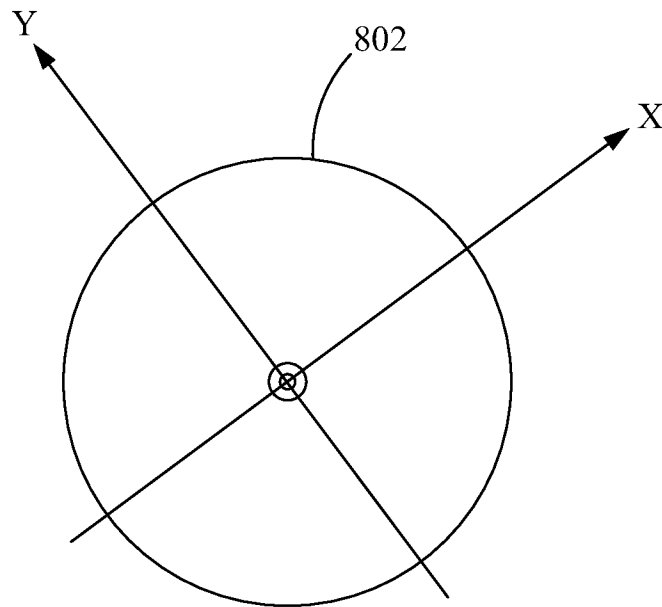

Fig. 10D

9/14

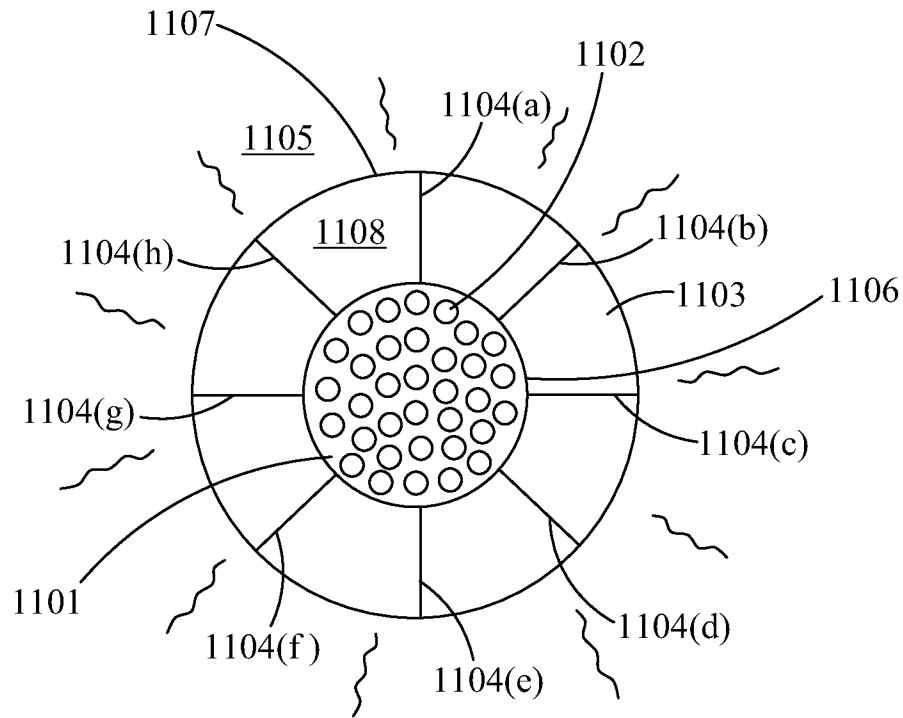

Fig. 11

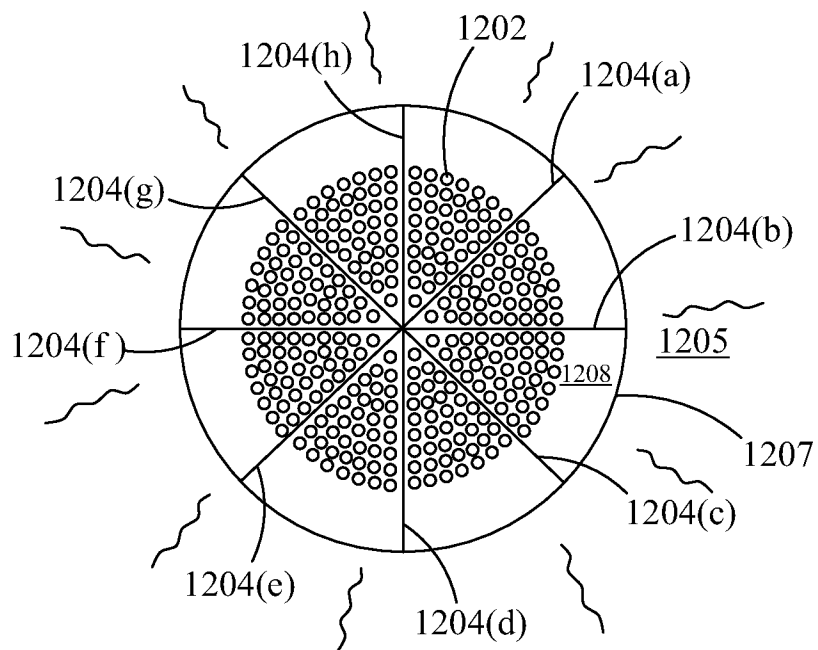

Fig. 12

10/14

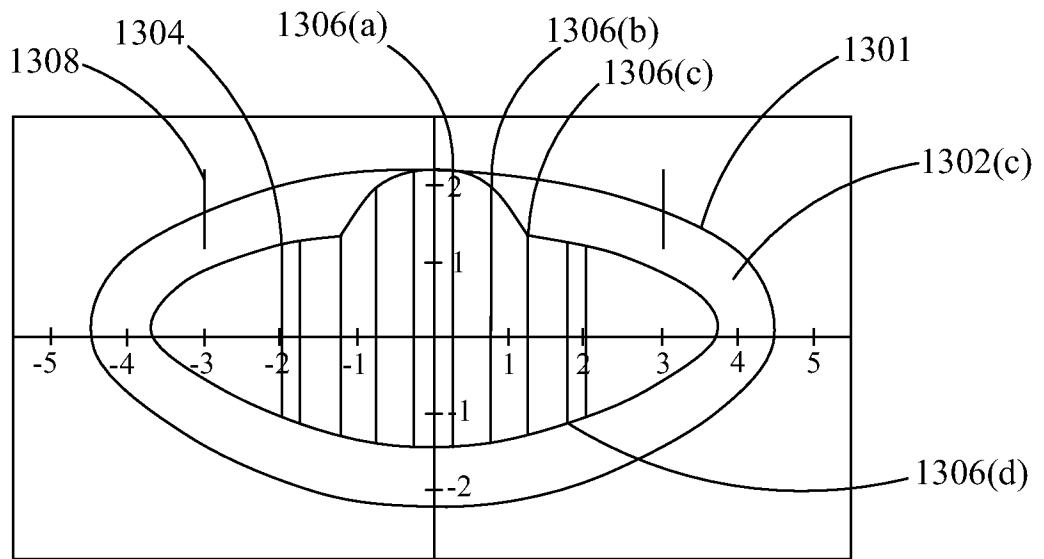

Fig. 13A

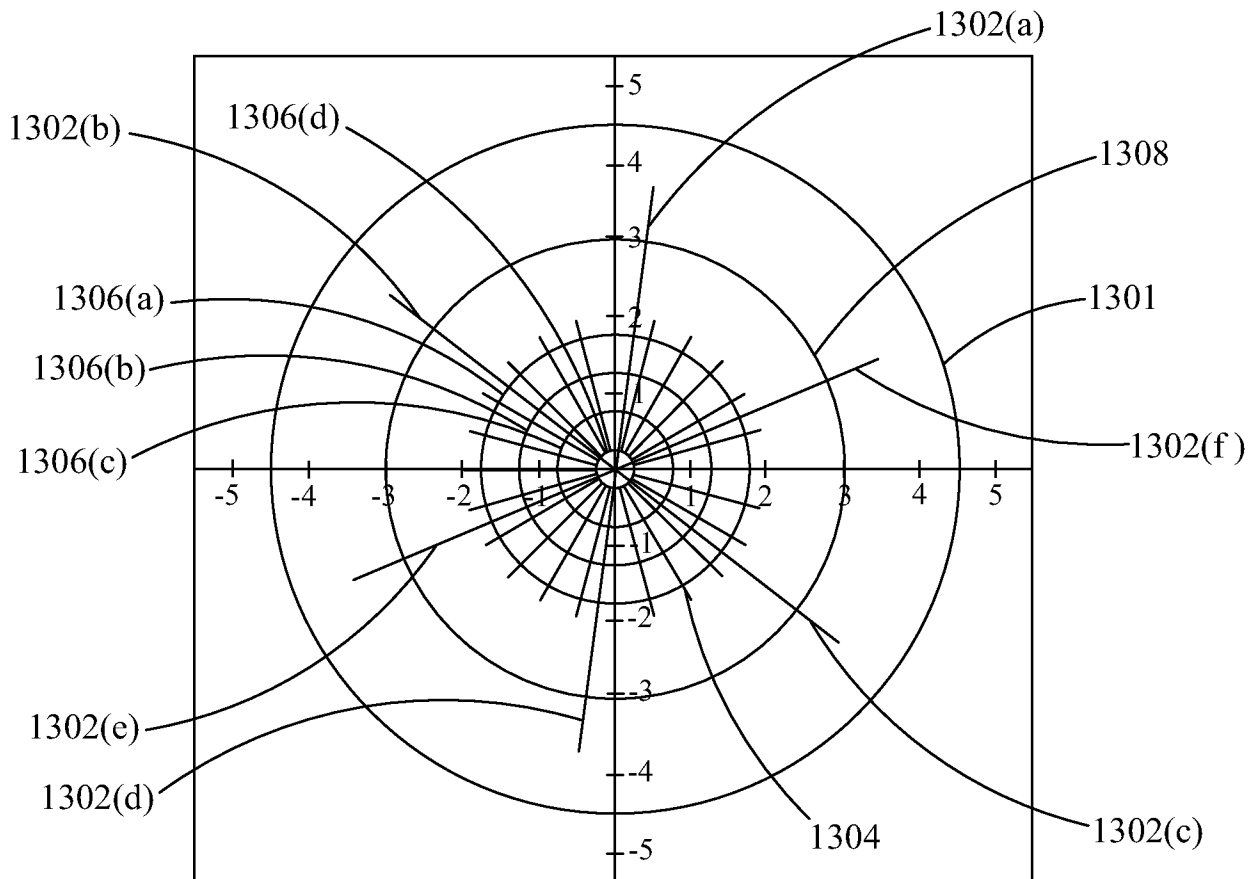

Fig. 13B

11/14

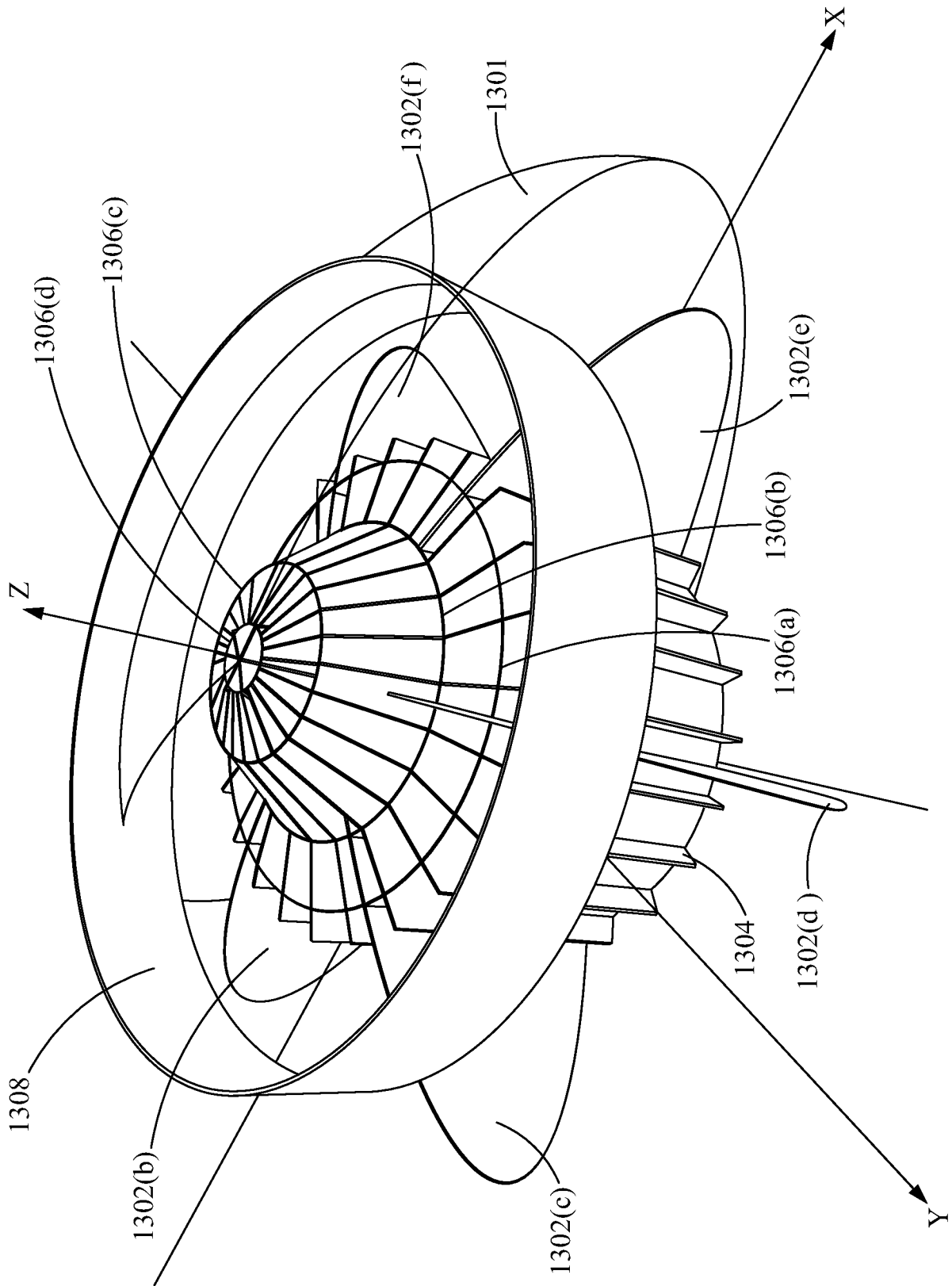

Fig. 13C

12/14

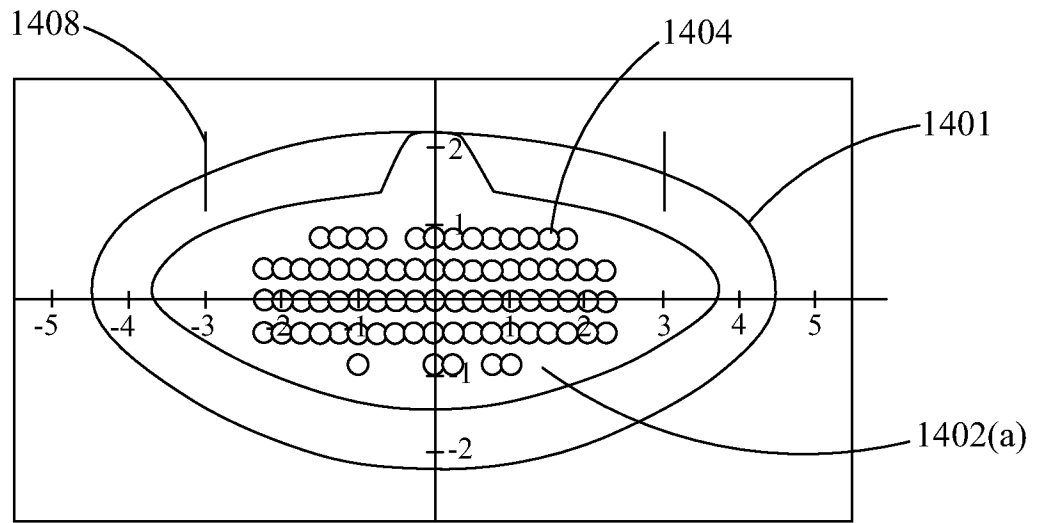

Fig. 14A

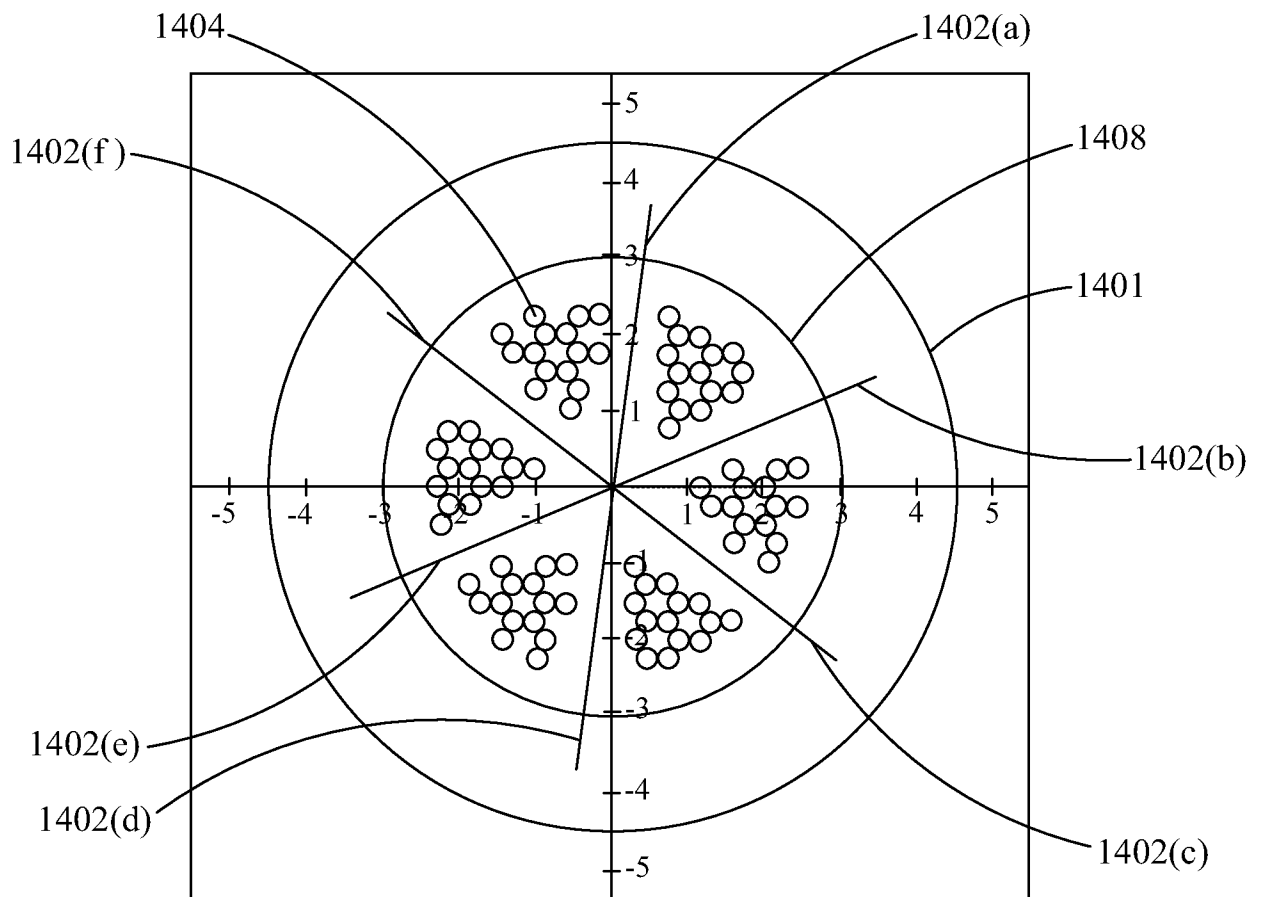

Fig. 14B

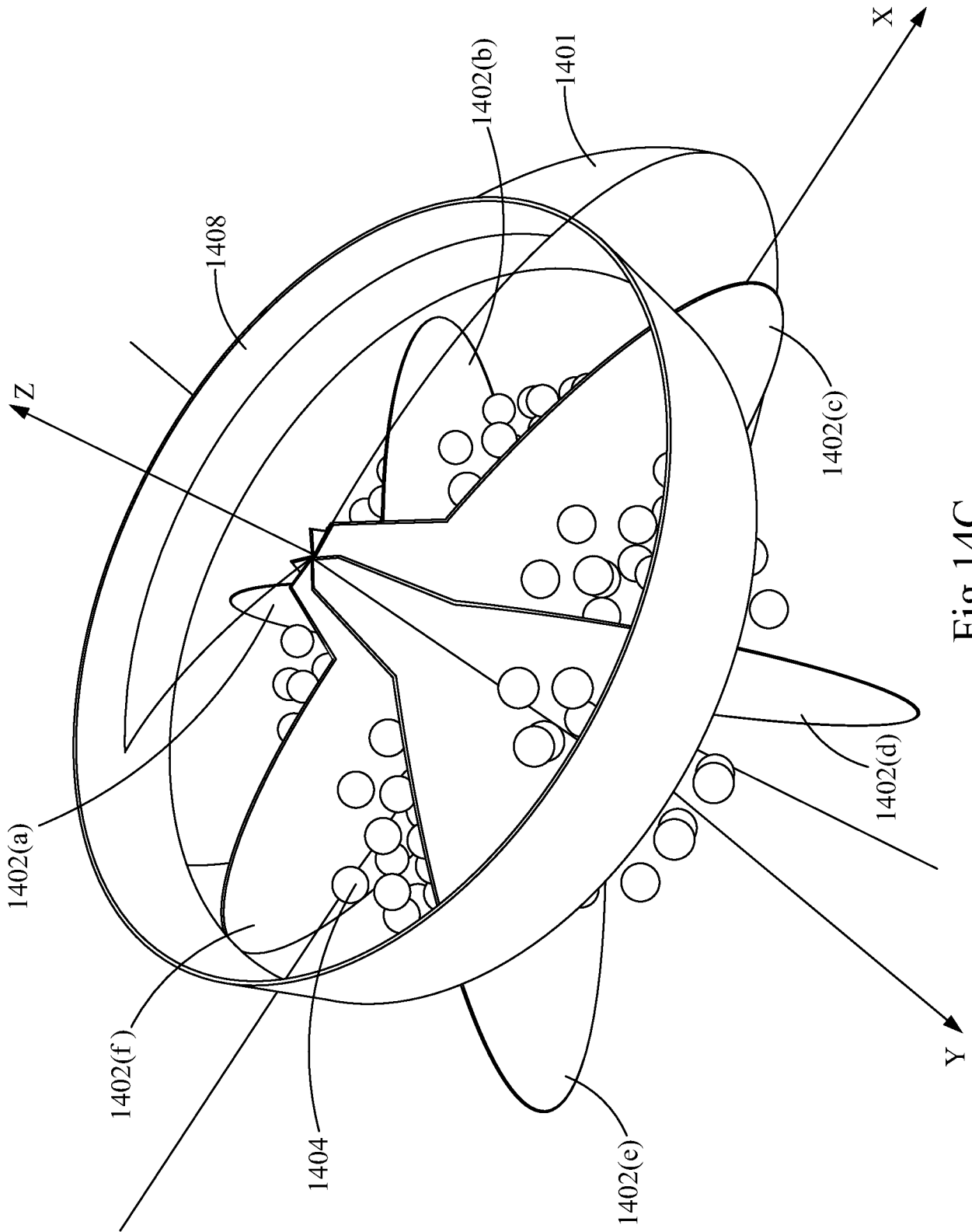

Fig.14C

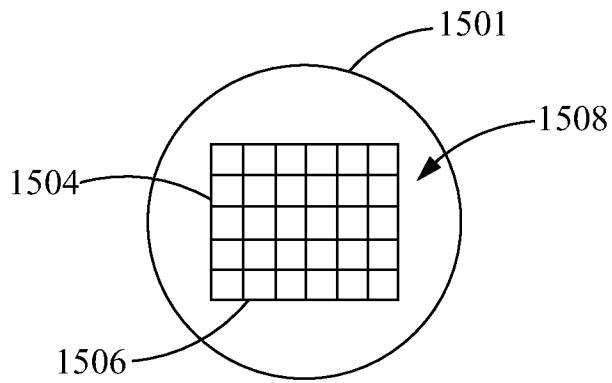

Fig. 15A

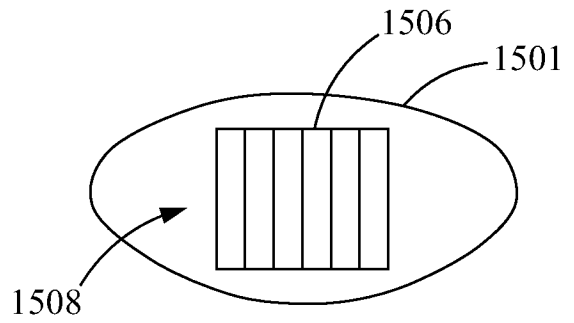

Fig. 15B

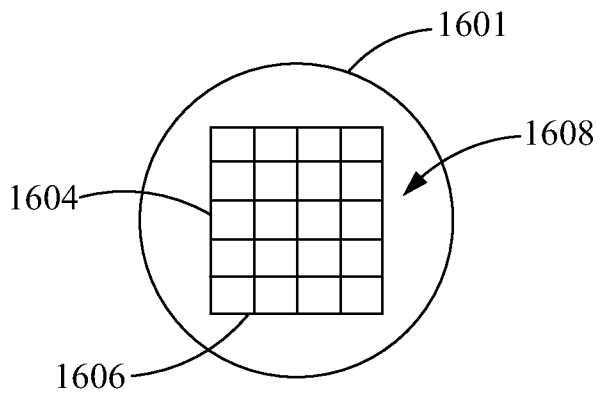

Fig. 16A

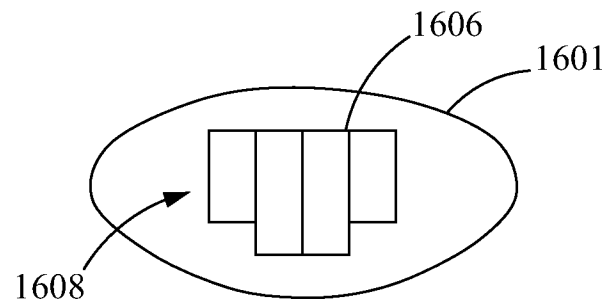

Fig. 16B

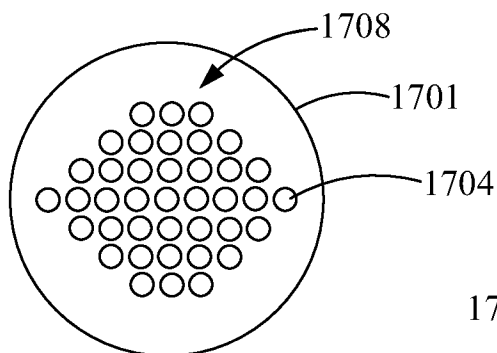

Fig. 17A

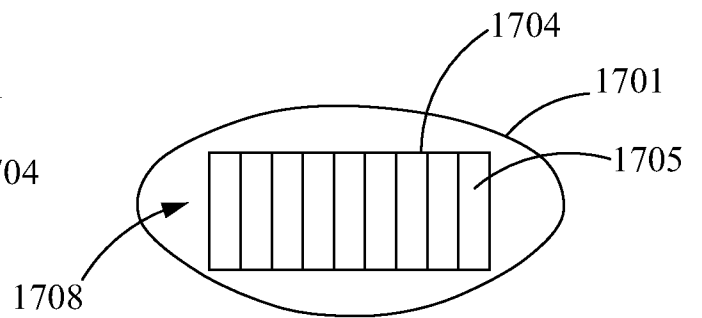

Fig. 17B

A. CLASSIFICATION OF SUBJECT MATTER IPC(8) - A61B 18/20 (2010.01) USPC - 606/4 According to International Patent Classification (IPC) or to both national classification and IPC		
B. FIELDS SEARCHED Minimum documentation searched (classification system followed by classification symbols) IPC(8) - A61B 18/20 (2010.01) USPC - 606/4, 5, 6, 10, 11, 13 Documentation searched other than minimum documentation to the extent that such documents are included in the fields searched Electronic data base consulted during the international search (name of data base and, where practicable, search terms used) PatBase, Google Scholar		
C. DOCUMENTS CONSIDERED TO BE RELEVANT		
Category*	Citation of document, with indication, where appropriate, of the relevant passages	Relevant to claim No.
X	US 2007/0185475 A1 (FREY et al) 09 August 2007 (09.08.2007) entire document	21-29, 46-54, 60-66
Y		1-20, 30-45, 55-59, 67
Y	US 2003/0050629 A1 (KADZIAUSKAS et al) 13 March 2003 (13.03.2003) entire document	1-20, 30-45, 55-59, 67
A	US 2007/0173794 A1 (FREY et al) 26 July 2007 (26.07.2007) entire document	1-67
A	US 6,322,556 B1 (GWON et al) 27 November 2001 (27.11.2001) entire document	1-67
<input type="checkbox"/> Further documents are listed in the continuation of Box C. <input type="checkbox"/>		
* Special categories of cited documents: "A" document defining the general state of the art which is not considered to be of particular relevance "E" earlier application or patent but published on or after the international filing date "L" document which may throw doubts on priority claim(s) or which is cited to establish the publication date of another citation or other special reason (as specified) "O" document referring to an oral disclosure, use, exhibition or other means "P" document published prior to the international filing date but later than the priority date claimed "T" later document published after the international filing date or priority date and not in conflict with the application but cited to understand the principle or theory underlying the invention "X" document of particular relevance; the claimed invention cannot be considered novel or cannot be considered to involve an inventive step when the document is taken alone "Y" document of particular relevance; the claimed invention cannot be considered to involve an inventive step when the document is combined with one or more other such documents, such combination being obvious to a person skilled in the art "&" document member of the same patent family		
Date of the actual completion of the international search 03 September 2010		Date of mailing of the international search report 10 SEP 2010
Name and mailing address of the ISA/US Mail Stop PCT, Attn: ISA/US, Commissioner for Patents P.O. Box 1450, Alexandria, Virginia 22313-1450 Facsimile No. 571-273-3201		Authorized officer: Blaine R. Copenheaver PCT Helpdesk: 571-272-4300 PCT OSP: 571-272-7774