



- (51) International Patent Classification:
E04F 11/18 (2006.01) *E04H 17/16* (2006.01)
- (21) International Application Number:
PCT/AU2014/050202
- (22) International Filing Date:
29 August 2014 (29.08.2014)
- (25) Filing Language: English
- (26) Publication Language: English
- (30) Priority Data:
2013903297 29 August 2013 (29.08.2013) AU
2014902198 10 June 2014 (10.06.2014) AU
- (71) Applicant: SMART GLASS SYSTEMS PTY LTD
[AU/AU]; c/o Davies Collison Cave, Level 14, 255 Elizabeth Street, Sydney, New South Wales 2000 (AU).
- (72) Inventor: BIERMAN, Reynold; Unit 6, 14-18 Sheehy Street, Glebe, New South Wales 2037 (AU).
- (74) Agent: DAVIES COLLISON CAVE; Level 14, 255 Elizabeth Street, Sydney, New South Wales 2000 (AU).
- (81) Designated States (unless otherwise indicated, for every kind of national protection available): AE, AG, AL, AM,

AO, AT, AU, AZ, BA, BB, BG, BH, BN, BR, BW, BY, BZ, CA, CH, CL, CN, CO, CR, CU, CZ, DE, DK, DM, DO, DZ, EC, EE, EG, ES, FI, GB, GD, GE, GH, GM, GT, HN, HR, HU, ID, IL, IN, IR, IS, JP, KE, KG, KN, KP, KR, KZ, LA, LC, LK, LR, LS, LT, LU, LY, MA, MD, ME, MG, MK, MN, MW, MX, MY, MZ, NA, NG, NI, NO, NZ, OM, PA, PE, PG, PH, PL, PT, QA, RO, RS, RU, RW, SA, SC, SD, SE, SG, SK, SL, SM, ST, SV, SY, TH, TJ, TM, TN, TR, TT, TZ, UA, UG, US, UZ, VC, VN, ZA, ZM, ZW.

- (84) Designated States (unless otherwise indicated, for every kind of regional protection available): ARIPO (BW, GH, GM, KE, LR, LS, MW, MZ, NA, RW, SD, SL, ST, SZ, TZ, UG, ZM, ZW), Eurasian (AM, AZ, BY, KG, KZ, RU, TJ, TM), European (AL, AT, BE, BG, CH, CY, CZ, DE, DK, EE, ES, FI, FR, GB, GR, HR, HU, IE, IS, IT, LT, LU, LV, MC, MK, MT, NL, NO, PL, PT, RO, RS, SE, SI, SK, SM, TR), OAPI (BF, BJ, CF, CG, CI, CM, GA, GN, GQ, GW, KM, ML, MR, NE, SN, TD, TG).

Published:
— with international search report (Art. 21(3))



(54) Title: A MOUNTING ASSEMBLY FOR GLASS BALUSTRADE

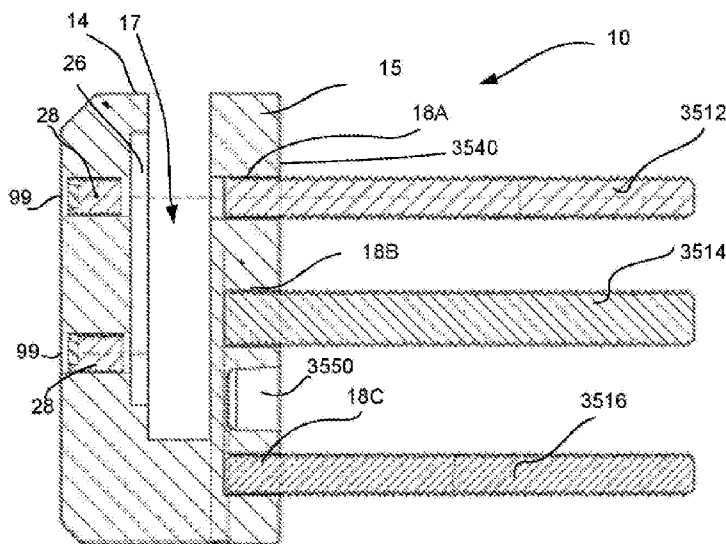

FIGURE 36

(57) Abstract: The present invention relates to a mounting 10 for glass balustrade and methods of installing the same. In particular aspects, the mounting 10 includes a first flange 14 and a second flange 15 that define therebetween a cavity 17 for receiving a glass panel 11. The mounting 10 also includes a clamping member 27 which can be actuated by a threaded member 28 provided in the first flange 14 to frictionally clamp the glass panel 11 within the cavity 17. The mounting 10 includes numerous securing holes for securing to a structure 22 such as a cement pad, a beam, or a piece of timber. In certain aspects, the mounting is configured to clamp two corner portions of separate panels of glass 110, 120 to form the glass balustrade.

A MOUNTING ASSEMBLY FOR GLASS BALUSTRADE

Related Applications

[001] This application claims priority from Australian Provisional Application 2013903297 filed 29 August 2013 and Australian Provisional Application 2014902198 filed 10 June 2014, the entire disclosures of which are incorporated by reference herein.

Technical Field

[002] The present invention relates to mountings for glass balustrade and method of installation.

Background

[003] It is not unusual for fencing and balustrades to be formed of panels, such as glass sheet. Where glass sheet is employed, it is not uncommon for the balustrade or fencing to be "frameless". This requires the sheet to be supported by spigots. Typically the spigots provide a slot within which the glass is secured.

[004] Each glass sheet is supported by two or more spigots, with the glass sheet being engaged by the spigots at positions spaced from the corners of the glass sheet, with the glass sheet being generally vertically orientated. The abovementioned spigots have the disadvantage that they are configured so that each spigot only engages a single sheet. Additionally, a problem with these abovementioned spigots is that they are only adapted to mount the sheet so that it extends generally upwardly from a horizontal surface, such as the floor of a balcony or a pool surround.

[005] Other mounting systems exist known as stand offs. This system involves holes being cut into the glass panels which can be time consuming and costly.

[006] There is therefore a need to overcome or at least alleviate one or more of the above-mentioned disadvantages or provide a useful commercial alternative.

- 2 -

[007] The reference in this specification to any prior publication (or information derived from it), or to any matter which is known, is not, and should not be taken as, an acknowledgement or admission or any form of suggestion that that prior publication (or information derived from it) or known matter forms part of the common general knowledge in the field of endeavour to which this specification relates.

Summary of Invention

[008] In a first aspect there is provided a method of securing a mounting to a structure for a glass balustrade arrangement, the mounting including a first flange having a first threaded hole, a second flange having a second threaded hole coaxial with the first threaded hole and also having a third threaded hole, a cavity located between the first and second flange, and one or more clamping members associated with the first and second flanges, wherein the method includes:

winding the mounting to secure a first threaded member which extends from the second flange into a first hole of the structure;

progressing a second threaded member through the first threaded hole of the first flange and partly through the second threaded hole of the second flange, wherein a portion of the second threaded member projects and secures within a second hole of the structure;

locating a glass panel within the cavity of the mounting; and

clamping the glass panel by actuating the one or more clamping members of the mounting, wherein at least a portion of the clamped glass panel overhangs an edge of the structure.

[009] In certain embodiments, the method includes securing the first threaded member with a third threaded hole located in the second flange.

[010] In certain embodiments, the method includes progressing a first screw located within the first threaded hole of the first flange after securing the second threaded member within the second hole of the structure, wherein progression of the first screw causes the first screw to contact one of the clamping members to thereby clamp the glass panel.

- 3 -

[011] In certain embodiments, the mounting includes an additional threaded hole in the first flange for receiving an additional screw, wherein the method includes progressing the additional screw within the additional threaded hole to contact one of the clamping members to thereby clamp the glass panel.

[012] In certain embodiments, the first screw is initially engaged within the first threaded hole, wherein the method includes withdrawing the first screw from the first threaded hole prior to progressing the second threaded member through the first threaded hole.

[013] In certain embodiments, the method includes inserting a portion of a tool through the first threaded hole to engage and progress the portion of the second threaded member through the second threaded hole of the second flange.

[014] In certain embodiments, the method includes:

- removing at least one clamping member from the mounting prior to progressing the second threaded member through the first threaded hole of the first flange; and

- relocating the at least one removed clamping member after the second threaded member has been secured within the second hole of the structure.

[015] In a second aspect there is provided a mounting for an adjacent pair of panels, the mounting including:

- a body having a first slot defined by a first pair of flanges and a second slot defined by a second pair of flanges, each slot being configured to receive a respective one of the panels so that the panels are supported in an upward orientation with adjacent edges;

- a first clamping member in the first slot;

- a second clamping member in the second slot; and

- a plurality of threaded fasteners threadably engaged with the body and engaged with the clamping members to urge the clamping members into clamping engagement with a respective one of the panels.

- 4 -

[016] In certain embodiments, the mounting includes a third clamping member and a fourth clamping member, the third clamping member being located in the first slot and positioned relative to the first clamping member so that the respective panel can be located therebetween, the fourth clamping member is located in the second slot and positioned relative to the second clamping member so that the respective panel can be located therebetween.

[017] In certain embodiments, the first pair of flanges are co-extensive and substantially parallel, and the second pair of flanges are co-extensive and substantially parallel.

[018] In certain embodiments, said body includes a spacer portion located between the pairs of flanges.

[019] In certain embodiments, the first slot is aligned with the second slot so that the slots are generally co-planar.

[020] In certain embodiments, the slots are inclined by an acute or obtuse angle.

[021] In certain embodiments, the slots are inclined by 90°.

[022] In certain embodiments, the body includes a stem to fix the mounting to a structure.

[023] In certain embodiments, the mounting includes a mounting flange, wherein the first and second pairs of flanges project substantially vertically and the mounting flange projects substantially horizontally, wherein the mounting flange includes a plurality of holes to fasten the mounting to a substantially horizontal surface of the structure.

[024] In certain embodiments, the body includes a rear surface which rests against a structure for the mounting to be secured thereto, wherein the rear surface includes one or more threaded holes for engaging a respective one or more threaded members to secure within holes defined in the structure.

- 5 -

[025] In certain embodiments, the body includes a threaded fastener hole to receive one of the threaded fasteners for engaging one of the clamping members, wherein the threaded fastener hole is coaxial with one of the threaded holes provided in the rear surface.

[026] In certain embodiments, one of the threaded holes in the rear surface is configured to receive a threaded screw which is progressed within the respective threaded hole for urging against the structure when the mounting is secured to the structure.

[027] In certain embodiments, the rear surface of the body includes a further threaded hole for receiving a threaded screw which is progressed within the further threaded hole for urging against the structure when the mounting is secured to the structure.

[028] In a third aspect there is provided a method of installing a mounting according to the first aspect, wherein the method includes:

- securing the mounting to a structure;
- locating a first glass panel within the first slot;
- locating a second glass panel within the second slot; and
- actuating the plurality of threaded fasteners to urge the clamping members to clamp against the first and second panels.

[029] In certain embodiments, the mounting includes a mounting flange, wherein the first and second pairs of flanges project substantially vertically and the mounting flange projects substantially horizontally, wherein the mounting flange includes a plurality of holes to fasten the mounting to a substantially horizontal surface of the structure, wherein the method includes securing the mounting flange to the substantially horizontal surface of the structure.

[030] In certain embodiments, the body includes a rear surface which rests against a structure for the mounting to be secured thereto, wherein the rear surface includes one or more threaded holes, wherein the method includes:

- 6 -

engaging a respective one or more threaded members with the one or more threaded holes in the rear surface; and

securing each threaded member within holes defined in the structure.

[031] In certain embodiments, the body includes a threaded fastener hole to receive one of the threaded fasteners for engaging one of the clamping members, wherein the threaded fastener hole is coaxial with one of the threaded holes provided in the rear surface, wherein the method includes progressing one of the threaded members through the threaded fastener hole and to at least partially progress the respective threaded member to project through the coaxial threaded hole provided in the rear surface.

[032] In certain embodiments, the method includes inserting a portion of a tool through the threaded fastener hole to progress the threaded member to project rearward of the rear surface.

[033] In certain embodiments, the method includes progressing a threaded screw within one of the threaded holes for urging against the structure when the mounting is secured to the structure.

[034] In certain embodiments, the rear surface of the body includes a further threaded hole for receiving a further threaded screw, wherein the method includes progressing the further threaded screw within the further threaded hole for urging against the structure when the mounting is secured to the structure.

[035] In a fourth aspect there is provided a mounting for a glass panel of a glass balustrade arrangement, the mounting including:

a base, the base being of a "U-shaped" configuration so as to have a first and a second flange joined by an end flange, the flanges providing an open cavity within which the glass panel is to rest so as to be at least partly supported by the mounting with the glass panel generally upwardly oriented, wherein the first and second flanges are generally upright, and said end flange is a bottom flange;

- 7 -

a clamping member adjacent the first flange and located in the cavity;

at least one threaded fastener engaged with said first flange and clamping member to urge the clamping member to engage the glass panel to clamp the glass panel between the second flange and clamping member to fix the glass panel to the mounting; and wherein

the second flange has at least one aperture which at least another threaded fastener engages to fix the mounting to a substantially vertical surface of an edge of a structure such that at least a portion of the glass panel which rests within the cavity overhangs the edge of the structure.

[036] In certain embodiments, said second flange has an inner surface to be located adjacent the glass panel, and an outer surface, with each aperture extending between the inner and outer surfaces.

[037] In certain embodiments, said inner and outer surfaces are generally upright.

[038] In certain embodiments, the clamping member includes or at least is partially made of a polymer material.

[039] In certain embodiments, each aperture is generally horizontally extending.

[040] In certain embodiments, said cavity is open upwardly.

[041] In certain embodiments, said second flange includes a first flange portion that is generally upwardly oriented, and a second flange portion extending generally horizontally from the first flange portion, with at least one of the apertures formed in said second flange portion so as to be generally vertically extending.

[042] In certain embodiments, the first flange includes a threaded fastener hole to receive one of the threaded fasteners for urging the clamping member to clamp the glass panel,

- 8 -

wherein the threaded fastener hole is coaxial with one of the at least one aperture provided in the second flange.

[043] In certain embodiments, one of the at least one aperture in the second flange is configured to receive a threaded screw which is progressed within the respective aperture for urging against the structure when the mounting is secured thereto.

[044] In certain embodiments, the second flange includes a further aperture for receiving a threaded screw which is progressed within the further threaded hole for urging against the structure when the mounting is secured thereto.

[045] Other aspects and embodiments will be realised throughout the description of the preferred embodiments.

Brief Description of Drawings

[046] Example embodiments should become apparent from the following description, which is given by way of example only, of at least one preferred but non-limiting embodiment, described in connection with the accompanying figures.

[047] Figure 1 is a schematic sectioned side elevation of a glass sheet and mounting;

[048] Figure 2 is a schematic side elevation of a fence having a plurality of the mountings of Figure 1 supporting glass sheets;

[049] Figure 3 is a schematic rear elevation of the mounting of Figure 1;

[050] Figure 4 is a schematic front elevation of the mounting of Figure 1;

[051] Figure 5 is a schematic side elevation of a modification of the mounting of Figure 1;

[052] Figure 6 is a schematic sectioned side elevation of the mounting of Figure 5;

[053] Figure 7 is a schematic side elevation of a glass fence employed in the mounting of Figure 5;

[054] Figure 8 is a schematic side elevation of a glass fence;

[055] Figure 9 is a schematic side elevation of portion of the fence of Figure 8 in side elevation;

[056] Figure 10A is a schematic isometric view of the mounting of Figure 9;

[057] Figure 10B is a schematic cross-section view of the mounting of Figure 9;

[058] Figure 11 is a schematic front elevation of the mounting of Figure 9;

[059] Figure 12 is a schematic rear elevation of the mounting of Figure 9;

[060] Figure 13 is an schematic isometric view of a cover strip for a mounting;

[061] Figure 14 is a schematic end elevation of the cover strip of Figure 13;

[062] Figure 15 is a schematic further front elevation of a fence;

[063] Figure 16 is a schematic sectioned plan view of a mounting employed in the fence of Figure 15;

[064] Figure 17 is a schematic front elevation of a pair of glass sheets and a mounting therefore;

- 10 -

[065] Figure 18 is a schematic parts sectioned plan view of the glass sheets and mounting of Figure 17;

[066] Figure 19 is a schematic side elevation of a modification of the mounting of Figure 17;

[067] Figure 20 is a schematic front elevation of the mounting of Figure 19;

[068] Figure 21 is a schematic sectioned side elevation of the mounting of Figure 19;

[069] Figure 22 is a schematic top plan view of the mounting of Figure 19;

[070] Figure 23 is a schematic side elevation of a modification of the mounting of Figure 17;

[071] Figure 24 is a schematic front elevation of the mounting of Figure 23;

[072] Figure 25 is a schematic sectioned front elevation of the mounting of Figure 23;

[073] Figure 26 is a schematic top plan view of the mounting of Figure 23;

[074] Figure 27 is a schematic isometric of a joining bracket for glass sheet;

[075] Figure 28 is a schematic top plan of modification of the bracket of Figure 27;

[076] Figure 29 is a schematic isometric view of a further modification of the bracket of Figure 27;

[077] Figure 30 is a schematic plan view of a mounting for a glass sheet;

[078] Figure 31 is a schematic side elevation of a mounting for glass sheet;

- 11 -

- [079] Figure 32 is a schematic isometric view of a mounting for glass sheet;
- [080] Figure 33A is a schematic side isometric view of the mounting of Figure 32;
- [081] Figure 33B is a cross-section side view of the mounting of Figure 32 when installed to a structure;
- [082] Figure 34A is a schematic front isometric view of a modification of the mounting of Figure 32;
- [083] Figure 34B is a schematic partial side isometric view of the mounting of Figure 34A;
- [084] Figure 34C is a cross-section side view of the mounting of Figure 34A when installed to a structure;
- [085] Figure 35 is a perspective view of another example of a mounting;
- [086] Figure 36 is a cross-sectional view of the mounting of Figure 35;
- [087] Figure 37 is a rear view of the mounting of Figure 35;
- [088] Figure 38 is a rear perspective view of the mounting of Figure 35;
- [089] Figure 39 is a front perspective view of the mounting of Figure 35;
- [090] Figure 40 is a first perspective view of a modification of the mounting of Figure 35;
- [091] Figure 41 is second perspective view of the mounting of Figure 40;

- 12 -

[092] Figure 42 is a rear perspective view of the mounting of Figure 40;

[093] Figure 43 is a perspective view of a clamping plate of the mounting of Figure 40;

[094] Figure 44 is a cross-sectional side view of a modification of the mounting of Figure 40 being installed to a structure;

[095] Figure 45 is a cross-section side view of the mounting of Figure 44 upon installation to the structure;

[096] Figure 46 is a flowchart representing a method of installation of the mounting of Figure 35 to a structure such as timber; and

[097] Figure 47 is a flowchart representing a method of installation of the mounting of Figures 44 and 45 to a structure such as concrete.

Description of Embodiments

[098] The following modes, given by way of example only, are described in order to provide a more precise understanding of the subject matter of a preferred embodiment or embodiments. In the figures, incorporated to illustrate features of an example embodiment, like reference numerals are used to identify like parts throughout the figures.

[099] In Figures 1 to 4 there is schematically depicted a mounting 10 for a panel such as glass sheet 11. Typically a plurality of the mountings 10 would be employed to support a plurality of the sheets 11 so as to fix the sheets 11 to a generally upright surface (such as the edge of a concrete pad) 12. The sheets 11 would extend upwardly from a generally horizontally oriented floor surface 13.

[0100] The mounting 10 is of a generally "U-shaped" configuration so as to have a first generally upright flange 14 and a second generally upright flange 15. The flanges 14 and 15 are spaced and preferably parallel and co-extensive, and joined by a bottom (end) flange

- 13 -

16. The flanges 14, 15 and 16 cooperate to provide an upwardly open cavity 17 within which one of the sheets 11 is located so as to be supported by the mountings 10 and secured in a generally upright orientation fixed to the surface 12.

[0101] In this embodiment the flange 15 has an inner generally upright inner surface 19 (adjacent the sheet 11) and a generally upright outer surface 20. Passages 18 extend generally horizontally between the surfaces 19 and 20 so that the threaded fasteners 21 may pass through the flange 15 and be engaged in the concrete pad 22 to fix the mounting 10 to the concrete pad 22. Preferably, the flange 15 has recesses 23 within which the head of each of the fasteners 21 may be located.

[0102] In the present embodiment the mounting 10 is an assembly in respect of the flanges 14, 15 and 16, with the flange 16 secured to the flange 15, and slab 22 by one or more of the threaded fasteners 18, with the flange 14 provided with a cavity 24 to receive the head from the threaded fastener 18. The flange 14 is secured to the flange 16 (and therefore the flange 15) by further threaded fasteners 25.

[0103] The flange 14 at its internal face is provided with a cavity 26 that receives a clamp pad 27 preferably formed of plastics material. The pad 27 is urged into engagement with the sheet 11 by threaded fasteners 28 so that the sheet 11 is frictionally retained in the recess 17. As can be seen in Figures 1 to 4, the threaded fasteners 28 engage with threaded holes 99 provided by flange 14.

[0104] In the embodiment of Figures 5, 6 and 7, the mounting 10 is modified so as to engage the corners of the panels 11. More particularly one of the flanges 14, 15 or 16 is provided with a projection 29 that is located between adjacent edges 30 of adjacent panels 11.

[0105] In Figures 8 to 12 there is illustrated a further modification of the mounting 10. In this embodiment the flange 15 includes a first flange portion 31 that is generally vertically oriented, and a second flange portion 32 that is generally horizontally oriented so as to

- 14 -

project laterally from the flange portion 31. The flange portion 32 is provided with a plurality of apertures 33 through which threaded fasteners 34 pass to engage in the concrete slab 22 to secure the mounting 10 to the concrete pad 22, and more particularly the generally horizontal surface 35 of the concrete pad 22. However the sheet 11 is adjacent the surface 12. As shown in Figure 10B, mortar 3300 may be placed at the rear of the second flange portion 32 and also over the top surface of the second flange portion 32 to enable a tiles or tiles 3310 to be laid over the second flange portion such that the second flange portion is not visible. As also shown in Figure 10B, the mounting 10 can include a passage 102 that passes through flanges 14, 15 and 16 to enable an optional bolt to secure the mounting to the structure 22.

[0106] In Figures 13 and 14 there is schematically depicted a cover strip 36 for securing to the mounting 10. The cover strip 36 extends longitudinally of the mounting 10 and includes an upper flange 37 with a downwardly extending lip 38 that engages in the recess 17 so as to be located between the panel 11 and the rear surface of flange 14. Extending downwardly from the flange 37 is a flange 39 that extends downwardly over the flange 14. Extending laterally from a lower portion of the flange 39 is a further horizontal flange 40 that extends across the lower surfaces of the flanges 14, 15 and 16. A threaded fastener 41 passes through the flange 40 and engages in the threaded passage in the lower portions of one of the flanges 14, 15 or 16. Whilst Figures 13 and 14 depict that the cover strip 36 includes the downwardly extending lip 38, it is possible that the cover strip 36 is not provided with the downwardly extending lip 38. In this variation, the upper flange 37 is secured to the mounting 10 via a fastener such as a screw or the like.

[0107] In Figures 15 and 16 there is schematically depicted the panels 11 and mountings 10, together with an additional support bracket 42. The bracket 42 engages a generally upwardly extending edge portion of the panel 11 while the mountings 10 engage a generally horizontally extending lower edge portion of the panels 11.

[0108] As shown in Figure 16, the bracket 42 includes a base 43 that is of an "L" configuration so as to have a flange portion 44 and an end portion 45. The bracket 42

- 15 -

includes a further flange portion 46 with a threaded fastener 47 passing through the flange portions 44 and 46 and end portion 45. The portions 44, 45 and 46 cooperate to provide a generally horizontally open cavity 48 that receives the vertical edge portion of the panel 11. The flange portions 44 and 46 are generally co-extensive and parallel. The threaded fastener 47 engages within concrete slab 22 to fix the bracket 42 to the slab 22.

[0109] Referring to Figures 35 to 37 there is shown a further example of the mounting 10. In particular the second side flange 15 includes three apertures 18A, 18B, 18C, wherein each aperture can receive therein a corresponding threaded fastener 3512, 3514, 3516 to engage a structure to fix the mounting 10 to the structure. Preferably, the second side flange 15 is attached to a substantially vertical surface, such as the vertical surface of an edge of a concrete slab or the like as shown in Figures 1, 6 and 8. As the second flange 15 of the mounting 10 is secured substantially flush against the vertical surface structure, the area of the horizontal surface of the structure such as a balcony is free of upstanding stems and the like. In this arrangement, at least a portion of the glass panel 11 which rests within the cavity 17 overhangs the edge of the structure. Therefore, the "over-the-edge" mounting arrangement provides a significant advantage as it allows for better utilisation of the usable horizontal space. The mounting 10 also provides significant aesthetic advantages as there are no unsightly upstanding stems associated with the mounting 10 which protrude from the horizontal surface adjacent the edge of the structure. Furthermore, the mounting 10 provides safety advantages as the reduction of upwardly extending stems removes various tripping hazards.

[0110] As shown in Figure 36, the top aperture 18A in the second flange 15 passes through the second flange 15 and into the cavity which can be advantageous for particular installations methods as will be discussed below. The other two apertures 18B, 18C are blind holes which do not pass through the second flange 15 and into the cavity 17.

[0111] As shown in Figures 35 and 37, the rear surface 3540 of the second side flange 15 includes cut-out sections 3550 to reduce the amount of material of the mounting 10 as well

- 16 -

as reduce the weight of the mounting 10 to approximately 2 kilograms. In a particular embodiment, the mounting 10 is made of stainless steel.

[0112] The mounting 10 of Figures 35 to 37 is preferably designed for glass balustrade. Figures 38 and 39 additionally show perspective views of the mounting 10 which includes a front and rear clamping member 27, 3900. A glass panel is located between the first 14 and second flanges 15 of the mounting 10, wherein the panel is clamped between the first and second clamping members 27, 3900. It will be appreciated that whilst the front clamping member 27 moves as will be discussed below, the rear clamping member 3900 does not move. The clamping members 27, 3900 are preferably at least partially made of a rubber or polymer material to ensure that the glass panel 11 is not marked when a clamping force is applied.

[0113] As shown in Figures 36 and 39, the first flange 14 includes two threaded apertures 99 which pass through the first flange 14 and into the cavity 17. A pair of grub screws 28 are screwed into the threaded apertures 99. The ends of the two grub screws 28 press against a surface of the front clamping member 27 as the screws 28 are screwed into engagement with the threaded apertures 99. When the two threaded fasteners 28 are tightened using an Allen key or the like, the threaded members 28 urge against the surface of the front clamping plate 27 which moves toward and clamps against the front surface of the glass panel 11 located within the cavity such as to fix the panel within the cavity 17 of the mounting 10.

[0114] As shown in Figure 36 and 38, the front clamping plate 27 is tight fittingly received within a recess 26 within the inner wall of the flange 14. As the grub screws 28 are tightened and the respective ends of the grub screws 28 protrude outward from the inner wall of the flange 14, the front clamping plate 27 is displaced from the recess 26 to clamp against the front surface of the glass panel 11.

[0115] As shown in Figure 39, the rear clamping plate 3900 includes an "L" shaped profile including a rear plate member 3930 which rests against the inner rear wall of the flange 15

- 17 -

and a base plate member 3940 which rests upon the base 16 of the cavity 17 of the mounting 10. Both clamping members 27, 3900 can be removed from the mounting 10 in order to aid installation and then reinserted into the cavity prior to securing the glass panel as will be discussed below. The clamping members 27, 3900 can be provided with one or more portions of re-adherable glue on the rear surfaces. The re-adherable glue for the clamping member 27 helps retain the clamping member 27 within recess 26 whilst the mounting is being installed whilst still allowing the clamping member 27 to be removed for particular installation processes and also urged into frictional contact with the glass panel 11. The re-adherable glue for the clamping member 3900 helps maintain its position within the cavity 17.

[0116] A number of methods of installing the mounting of Figures 35 to 39 will now be described.

[0117] In particular, for concrete, one or more holes are drilled into the concrete structure for receiving one or more of the threaded members 3512, 3514, 3516. In particular, it is desirable for particular concrete installations such as a vertically thin concrete slab (~30cm to 50cm thick vertically) that only a single threaded fastener 3514 is used for installing the mounting 10 and as such only a single hole is drilled into the concrete slab. The single hole is generally drilled approximately 15 cm from the upper or lower surface of the concrete slab to enable the hole to withstand expected forces. However, in other situations where the structure which the mounting 10 is to be secured thereto is vertically thicker, one or more of threaded fasteners 3512, 3516 can additionally be used and thus corresponding holes are also drilled into the structure.

[0118] Next, the method includes screwing threaded members 3514 and optionally 3512 and 3516 into the second flange 15 of the mounting 10 via the holes 18B, 18A and 18C respectively. Next, the method includes aligning the mounting 10 with other mountings being secured to the structure or which have already been secured to the structure 22 using a string line or laser if required. Next, the threaded members 3514 and optionally 3512 and 3516 are secured into the holes in the structure 22 using an adhesive. Once the adhesive

- 18 -

has cured, the glass panel 11 can be located within the cavity 17 of the mounting 10. The grub screws 28 can then be tightened such that the clamping plates 27, 3900 clamp against the panel 11. Optionally, an additional nylon wedge gasket can be inserted under the glass panel 11 within the cavity 17 to adjust the top edge of the respective glass panel 11 so it is level with an adjacent glass panels prior to clamping. Optionally, lock tight metal adhesive may be used to secure the bolts 3512, and/or 3514 and/or 3516 within the flange 15 of the mounting 10.

[0119] In relation to installing the mounting 10 to metal or timber beams in easy to access areas, two bolts 3512, 3516 are screwed into the back of the mounting 10. Lock tight metal adhesive may be used to secure the bolts 3512, 3516 within the flange 15 of the mounting 10. The bolts 3512, 3516 can then pass through holes in the beam, wherein ends of the bolts 3512, 3516 which protrude from the rear of the beam are secured with washers and nuts such that the mounting 10 is secured to the beam. The glass panel 11 can then be inserted into the cavity 17, adjusted and aligned, and then secured as described above.

[0120] In relation to installing the mounting to a structure such as timber in difficult to access areas, this method will be described in relation to a flowchart depicted in Figure 46. At step 4605, a pair of holes are drilled into the timber in a vertical row. Next, the clamping plate 27 and optionally 3900 (as shown in Figure 43, the rear clamping plate 3900 can include holes so as to remain within the cavity 17 during installation if desired) are removed from the mounting 10. At step 4615, a first bolt 3516 is screwed into one of the respective apertures 18C in the back of the mounting 10 such that it is secured to the mounting 10. The protruding end of the first bolt 3516 is then secured into the lower hole in the timber at step 4620, wherein the mounting 10 is wound in a clockwise direction (by convention but it will be appreciated that a bolt with an opposite thread could be provided) such that the first bolt 3516 is screwed into the timber into the hole. Other mountings can additionally be screwed into the timber and aligned as discussed in the other installation methods using a string line or laser alignment means. At step 4625, the top grub screw 28 which is co-axial with hole 18A is screwed out from flange 14. At step 4630, a second bolt 3512 is screwed into and through hole 99 of the flange 14 which then protrudes through

- 19 -

co-axial hole 18A in flange 15 such that the second bolt 3512 projects rearward from the flange 15 to engage with and protrude into an upper second hole in the timber. An Allen key may be used to engage an end of the second bolt 3512 to screw the second bolt through hole 99 and engage with hole 18A such that the second bolt no longer protrudes into the cavity 17. It will be appreciated that the Allen key can protrude through the flange 14 to engage the end of the second bolt 3512 for actuation. Once the second bolt 3512 has been screwed into the timber, at step 4635, the removed grub screw 28 can again be screwed back into the top hole 99 in the front flange 14 of the mounting 10. At step 4640, the clamping plate 27 and optionally 3900 can then be reinserted into the recess 26 and cavity 17 respectively. At step 4645, the glass panel 11 can also be inserted into the cavity 17. At step 4650, the grub screws 28 can be tightened such that the clamping plates 27, 3900 clamp against and secure the glass panel 11 within the cavity 17 by friction.

[0121] It will be appreciated by those skilled in the art that particular steps discussed above can be performed in different orders to achieve the same end result. For example, the second bolt 3512 can be loosely located within the hole 99 prior to winding, and then upon the winding process having been completed, then continuing with the progression of the second bolt 3512 to secure the mounting to the structure 22.

[0122] Referring to Figures 17 to 26 there is schematically depicted another embodiment of a mounting 100. The mounting 100 would be employed to support sheets (panels) 110 and 120 fixed to a supporting structure. The sheets 110 and 120 would extend upwardly relative to the structure.

[0123] The mounting 100 includes a body 130 that would be fixed to the structure so as to extend generally upwardly relative thereto. The upper end of the body 130 provides two pairs of flanges 140 and 150 that are preferably generally parallel and co-extensive. Located between the flanges 140 is a first slot 160, while located between the flanges 150 is a second slot 170. Each slot 160 and 170 receives a respective one of the sheets 110, 120, so that the slots 160 and 170, and sheets 110 and 120 are generally co-planar.

- 20 -

[0124] Located in the first slot 160 is at least one clamp plate 180. In this embodiment there are two clamp plates 180, with the sheet 110 located therebetween. In respect of the slot 170, clamp plates 190 are provided so as to be located in the slot 170 so that the sheet 120 is located therebetween.

[0125] Threadably engaged with the body 130 is a plurality of threaded fasteners 200 that engage the clamp plates 180 and 190 to urge the clamp plates 180 and 190 into engagement with the associated sheet 110, 120. By doing so, the plates 180 and 190 frictionally clamp the sheets 110 and 120 to the mounting 100.

[0126] Located between the first set of flanges 140 and the second set of flanges 150 is a spacer portion 210 of the body 130. The body 130 also provides a stem 240 to be fixed to the supporting structure 22.

[0127] The mounting 100 engages the sheets 110 and 120 adjacent the lower corners 220 thereof so that the mounting 100 is located adjacent the upwardly extending edges 230 of the sheets 110 and 120.

[0128] In Figures 19 to 22 there is schematically depicted a modification of the mounting 100. In this embodiment there are only two clamp plates 180, with each clamp plate 180 being engaged by a pair of threaded fasteners 200. Also in this embodiment, the stem 240 is generally circular in transverse cross-section and is provided with transverse passages 250. Additionally, the stem 240 is hollow so as to provide an upwardly extending cavity 260.

[0129] In Figures 23 to 26 there is schematically depicted a modification of the mounting 100. In this embodiment the pair of flanges 140 extends generally perpendicular to the flanges 150. Accordingly the mounting 100 provides for the supporting of glass sheet 110, 120 that is generally upwardly oriented, but with the sheets (and slots 140 and 150) inclined by approximately 90°. However it should be appreciated that the flanges 140 and 150 could be arranged at other angles apart from 90°.

- 21 -

[0130] In Figures 27 and 28 there are schematically depicted joining brackets 300. The brackets 300 include a first pair of flanges 310 and a second pair of flanges 320, with a first slot 330 being located between the flanges 310, and a second slot 340 being located between the flanges 320. The slots 330 and 340 are separated by a divider 350, with the assembly being secured together by one or more threaded fasteners 360. In one or both of the flanges 310, and one or both of the flanges 320, there is a clamp plate 370 engaged by a threaded fastener 380 so that the associated clamp plate 370 may be moved into frictional engagement with a glass sheet located in the associated slot 330 or 340. In the embodiment of Figure 27, the glass sheets (and slots 330 and 340) are generally co-planar. In the embodiment of Figure 28, the glass sheets (and slots 330 and 340) although still being vertically oriented, are inclined by approximately 90°. In that regard it should be appreciated that the flanges 310 and 320 may be inclined by other angles apart from 90°.

[0131] In Figure 29 there is schematically depicted a further bracket 400. Typically the bracket 400 would be located adjacent an upper edge of the glass sheet and will secure the glass sheet to an adjacent wall or other structure. The bracket 400 includes a pair of spaced flanges 410 between which there is located a slot 420 to receive a glass sheet. At least one of the flanges 410 would be provided with a clamp plate 430 an associated threaded fastener 440 to urge the plate 430 into frictional engagement to a glass sheet located in the slot 420. The assembly would be held together by means of a threaded fastener 450. Typically the bracket 400 would have an end wall 460 through which threaded fasteners would pass to engage adjacent wall or structure. As an alternative embodiment, the flange 410 could be provided with threaded fasteners again to secure the bracket 400 to an adjacent wall or structure.

[0132] In Figures 30 and 31 there is schematically depicted a mounting 500 for glass sheet. In this embodiment the mounting 500 is intended to be fixed to a building or structure so as to be adjacent a corner.

- 22 -

[0133] The mounting 500 includes a pair of generally parallel co-extensive flanges 510 between which there is located a generally vertically oriented slot 520. A pair of generally parallel co-extensive flanges 530 provides a slot 540. In this embodiment the slot 540 is generally perpendicular to the slot 520. However in other embodiments the slots 520 and 540 could be inclined by an acute or obtuse angle.

[0134] In the slot 520 there is provided a clamp plate 550 engaged by a threaded fastener 560 to urge the clamp plate 550 into frictional engagement with a glass sheet located in the slot 520. A similar clamp plate 570 is included in the slot 540 and engaged by a threaded fastener 580. Accordingly the glass sheets would be inclined by approximately 90° while also being generally vertically oriented.

[0135] In this embodiment one of the flanges 510 is provided with one or more threaded fasteners 590 to secure the mounting 500 to a support structure 22. Preferably the mounting 500 is secured together by means of one or more threaded fasteners 600.

[0136] In Figures 32 and 33A there is schematically depicted a mounting 1000. The mounting 1000 would receive and secure together two glass sheets with the glass sheets generally vertically oriented and with adjacent vertical edges. The sheets are preferably parallel. Preferably, the mounting 1000 would engage the lower adjacent corners of the glass sheets.

[0137] The mounting 1000 has a first pair of generally parallel and coextensive flanges 1010 and a second pair of generally parallel and coextensive flanges 1020. The flanges 1010 provides a cavity 1030 while the flanges 1020 provide a cavity 1040. Each cavity 1030 and 1040 receives a respective one of the glass sheets. Extending between each of the flanges 1010 and 1020 is an end (bottom) flange 1050 upon which the glass sheet can rest. The cavities 1030 and 1040 are separated by a divider 1060.

- 23 -

[0138] Extending from the flanges 1010 and 1020 is a mounting flange 1070 through which threaded fasteners would pass to secure the mounting 1000 to a generally horizontal supporting surface of an adjacent structure 22.

[0139] As shown in Figure 33B, one of the flanges 1010 and one of the flanges 1020 would be provided with a clamp plate 1080 and an associated threaded fastener 1090, with the threaded fasteners 109 urging the plates 1080 into clamping engagement with their respective glass sheet, wherein the rear surface of the glass sheet presses against the rear clamping plates 1085.

[0140] As can be seen in Figure 33B, the mounting flange 1070 can be placed onto the edge of the structure 22. Next, the mounting is secured to the structure 22 via fasteners which protrude through holes in the mounting flange 1070. Grout 3300 can then be placed over the remaining exposed top surface of the structure 22 as well as some of the top surface of the mounting flange 1070. Next, tiles 3310 can be placed over the laid grout 3300. It will be appreciated that this installation process covers the mounting flange 1070.

[0141] In the embodiment of Figures 32 and 33A and 33B, the flanges 1010 and 1020 are generally parallel. In the embodiment of Figures 34A and 34B the flanges 1020 are approximately perpendicular to the flanges 1010. However, acute or obtuse angles may also be employed. Figure 34C shows a similar installation of the mounting 1000 which was discussed in relation to Figure 33B and therefore it will be appreciated that a similar installation process applies for this embodiment of the mounting 1000, albeit the panels 110, 120 are inserted into and secured within the cavities 1030, 1040 at substantially perpendicular directions. The mounting 1000 can include a divider 1060, as illustrated in Figures 32 and 33A, which is located between the cavities 1030, 1040 to define the separation of the cavities 1030, 1040 and also to isolate the panels 110, 120 from each other when inserted and secured within the respective cavities 1030, 1040 of the mounting 1000.

- 24 -

[0142] Referring to Figures 40 to 42 there is shown another embodiment of the mounting 10. In particular the rear flange 15 includes an angled hole 4010 located adjacent the upper corner of the rear flange 15. The angled hole 4010 enables an additional bolt to be inserted into the hole 4010 to secure the mounting 10 to the structure 22 once the mounting 10 has been secured to the structure 22 with bolts 3512, and/or 3514, and/or 3516. Due to the angled orientation of the hole 4010 relative to the plane of the rear flange 15, a bolt can be inserted into the hole and a tool can be used to urge the bolt into place with relative ease despite the tight area within the cavity 17.

[0143] As also shown in Figures 40 and 41, the front flange 14 includes an angled upper front surface 4020 in order to prevent children or the like using the mounting as a step. The angled face 4020 is approximately 60 degrees relative to the horizontal.

[0144] Referring to Figure 43 there is shown an example of the second clamping plate 3900 for the mounting of Figure 40. The second clamping plate 3900 includes a cut-out section 4310 to enable the additional bolt to be inserted into angled hole 4010. Additionally, the second clamping plate 3900 includes a hole 4320 which is co-axial with hole 18A such that the second clamping plate 3900 need not be removed from the cavity 17 when installing the mounting 10 to timber and the like as discussed earlier.

[0145] Referring to Figures 44 and 45 there is shown another embodiment of the mounting 10 being secured to a concrete slab 22. Like features of the mounting 10 have been discussed in previous embodiments and should be appreciated by those skilled in the art. The rear flange 15 includes an additional hole 18D which is co-axial with the lower hole 99 which engages the grub screw 28.

[0146] A method of installing the mounting of Figures 44 and 45 will now be discussed in relation to the flowchart provided in Figure 47. In particular, at step 4705, a hole 4450 is drilled into the structure 22. At step 4710, the clamping plate 27 is removed from the recess 26. At step 4715, a bolt 3514 is secured to the hole 18B in the rear flange 15. At step 4720, the bolt 3514 projecting rearward of the rear flange 15 is secured into the hole 4450

- 25 -

in the structure 22. In particular, the bolt may be secured within the hole 4450 using an adhesive such that the rear surface of the rear flange sits substantially flush against the vertical structure 22. At step 4725, an angled hole 4490 can be drilled into the structure 22 via angled hole 4010 in the rear flange 15, wherein the mounting is secured to the structure using an additional bolt 4500 which has a longitudinal axis angled relative to the plane of the rear flange 15. At step 4730, the grub screws 28 are removed from the front flange 14 to expose holes 99 which are co-axial with holes 18A and 18D. At step 4735, grub screws 4410 and 4420 which are engaged within holes 18A and 18D are tightened by placing a tool, such as an Allen key 5000, through the holes 99 in turn such that a rear force is exerted against the structure 22 to provide further rigidity to the secured mounting 10. At step 4740, the grub screws 28 are replaced in holes 99. At step 4745, the clamping plate 27 is replaced in recess 26. At step 4750, the glass panel 11 is inserted into the cavity 17 and aligned with other panels 11 of other mountings 10. At step 4755, the grub screws are tightened using a tool such as the Allen key 5000 to urge the clamping plate 27 to urge against and clamp the panel 11 in combination with clamping plate 3900.

[0147] It will be appreciated by those skilled in the art that particular steps discussed above can be performed in different orders to achieve the same end result.

[0148] It will be appreciated that the grub screw arrangement 4410, 4420 for holes 18A, 18D can be used with other embodiments previously discussed such that the mounting is provided with additional rigidity in its installed state by exerting a rearward force against the vertical surface of the structure 22. In embodiments where the mounting secures multiple panels of glass, multiple pairs of holes 18A, 18D can be provided in the rear flange and multiple pairs of grub screws 4410, 4420 can be used to exert a force against the vertical surface of the structure 22.

[0149] It will be appreciated that the mounting 10 of Figures 35 and 44 provides substantial advantages in relation to the versatile installation methods for various structures. For concrete structures, the method described in relation to Figure 47 can be used. For structures such as timber which cannot utilise a nut and washer fastener

- 26 -

arrangement, the method described in relation to Figure 46 can be used. For structures such as beams, the method previously discussed in relation to nuts and washers can be utilised. It will be appreciated that hole 18A can be used for multiple purposes. For example, when the mounting 10 is being installed to concrete, the hole 18A engages the grub screw 4410 to exert a rearward force against the structure to provide additional rigidity for the installation of the mounting. In contrast, when the mounting 10 is being installed to timber, the hole 18A is used to engage a bolt 3512 which projects into the timber to secure the mounting to the structure 22.

[0150] It will also be appreciated that a kit may be provided which includes the mounting 10, a plurality of bolts and a plurality of grub screws to enable the installer to use the bolts and grub screws according to the particular structure 22 which the mounting is to be secured thereto.

[0151] It will be appreciated that in certain embodiments the mounting 10 may be integral with the threaded member 3514. In these embodiments, it is not necessary for the installer to engage the threaded member 3514 with the hole 18B.

[0152] Throughout this specification and the claims which follow, unless the context requires otherwise, the word "comprise", and variations such as "comprises" or "comprising", will be understood to imply the inclusion of a stated integer or step or group of integers or steps but not the exclusion of any other integer or step or group of integers or steps.

[0153] Many modifications will be apparent to those skilled in the art without departing from the scope of the present invention.

Claims

1. A method of securing a mounting to a structure for a glass balustrade arrangement, the mounting including a first flange having a first threaded hole, a second flange having a second threaded hole coaxial with the first threaded hole and also having a third threaded hole, a cavity located between the first and second flange, and one or more clamping members associated with the first and second flanges, wherein the method includes:

winding the mounting to secure a first threaded member which extends from the second flange into a first hole of the structure;

progressing a second threaded member through the first threaded hole of the first flange and partly through the second threaded hole of the second flange, wherein a portion of the second threaded member projects and secures within a second hole of the structure;

locating a glass panel within the cavity of the mounting; and

clamping the glass panel by actuating the one or more clamping members of the mounting, wherein at least a portion of the clamped glass panel overhangs an edge of the structure.

2. The method according to claim 1, wherein the method includes securing the first threaded member with a third threaded hole located in the second flange.

3. The method according to claim 1 or 2, wherein the method includes progressing a first screw located within the first threaded hole of the first flange after securing the second threaded member within the second hole of the structure, wherein progression of the first screw causes the first screw to contact one of the clamping members to thereby clamp the glass panel.

4. The method according to claim 3, wherein the mounting includes an additional threaded hole in the first flange for receiving an additional screw, wherein the method includes progressing the additional screw within the additional threaded hole to contact one of the clamping members to thereby clamp the glass panel.

- 28 -

5. The method according to claim 3 or 4, wherein the first screw is initially engaged within the first threaded hole, wherein the method includes withdrawing the first screw from the first threaded hole prior to progressing the second threaded member through the first threaded hole.

6. The method according to any one of claims 1 to 5, wherein the method includes inserting a portion of a tool through the first threaded hole to engage and progress the portion of the second threaded member through the second threaded hole of the second flange.

7. The method according to any one of claims 1 to 6, wherein the method includes:
removing at least one clamping member from the mounting prior to progressing the second threaded member through the first threaded hole of the first flange; and
relocating the at least one removed clamping member after the second threaded member has been secured within the second hole of the structure.

8. The mounting for an adjacent pair of panels, the mounting including:
a body having a first slot defined by a first pair of flanges and a second slot defined by a second pair of flanges, each slot being configured to receive a respective one of the panels so that the panels are supported in an upward orientation with adjacent edges;
a first clamping member in the first slot;
a second clamping member in the second slot; and
a plurality of threaded fasteners threadably engaged with the body and engaged with the clamping members to urge the clamping members into clamping engagement with a respective one of the panels.

9. The mounting according to claim 8, wherein the mounting includes a third clamping member and a fourth clamping member, the third clamping member being located in the first slot and positioned relative to the first clamping member so that the respective panel can be located therebetween, the fourth clamping member is located in the second slot and positioned relative to the second clamping member so that the respective

panel can be located therebetween.

10. The mounting according to claim 8 or 9, wherein:
the first pair of flanges are co-extensive and substantially parallel; and
the second pair of flanges are co-extensive and substantially parallel.
11. The mounting according to claim 10, wherein said body includes a spacer portion located between the pairs of flanges.
12. The mounting according to any one of claims 8 to 11, wherein the first slot is aligned with the second slot so that the slots are generally co-planar.
13. The mounting according to any one of claims 8 to 11, wherein the slots are inclined by an acute or obtuse angle.
14. The mounting according to any one of claims 8 to 11, wherein the slots are inclined by 90° .
15. The mounting according to any one of claims 8 to 14, wherein the body includes a stem to fix the mounting to a structure.
16. The mounting according to any one of claims 8 to 14, wherein the mounting includes a mounting flange, wherein the first and second pairs of flanges project substantially vertically and the mounting flange projects substantially horizontally, wherein the mounting flange includes a plurality of holes to fasten the mounting to a substantially horizontal surface of the structure.
17. The mounting according to any one of claims 8 to 14, wherein the body includes a rear surface which rests against a structure for the mounting to be secured thereto, wherein the rear surface includes one or more threaded holes for engaging a respective one or more threaded members to secure within holes defined in the structure.

- 30 -

18. The mounting according to claim 17, wherein the body includes a threaded fastener hole to receive one of the threaded fasteners for engaging one of the clamping members, wherein the threaded fastener hole is coaxial with one of the threaded holes provided in the rear surface.

19. The mounting according to claim 17 or 18, wherein one of the threaded holes in the rear surface is configured to receive a threaded screw which is progressed within the respective threaded hole for urging against the structure when the mounting is secured to the structure.

20. The mounting according to claim 19, wherein the rear surface of the body includes a further threaded hole for receiving a threaded screw which is progressed within the further threaded hole for urging against the structure when the mounting is secured to the structure.

21. A method of installing a mounting according to claim 8, wherein the method includes:

- securing the mounting to a structure;
- locating a first glass panel within the first slot;
- locating a second glass panel within the second slot; and
- actuating the plurality of threaded fasteners to urge the clamping members to clamp against the first and second panels.

22. The method according to claim 21, wherein the mounting includes a mounting flange, wherein the first and second pairs of flanges project substantially vertically and the mounting flange projects substantially horizontally, wherein the mounting flange includes a plurality of holes to fasten the mounting to a substantially horizontal surface of the structure, wherein the method includes securing the mounting flange to the substantially horizontal surface of the structure.

- 31 -

23. The method according to claim 21, wherein the body includes a rear surface which rests against a structure for the mounting to be secured thereto, wherein the rear surface includes one or more threaded holes, wherein the method includes:

engaging a respective one or more threaded members with the one or more threaded holes in the rear surface; and

securing each threaded member within holes defined in the structure.

24. The method according to claim 23, wherein the body includes a threaded fastener hole to receive one of the threaded fasteners for engaging one of the clamping members, wherein the threaded fastener hole is coaxial with one of the threaded holes provided in the rear surface, wherein the method includes progressing one of the threaded members through the threaded fastener hole and to at least partially progress the respective threaded member to project through the coaxial threaded hole provided in the rear surface.

25. The method according to claim 24, wherein the method includes inserting a portion of a tool through the threaded fastener hole to progress the threaded member to project rearward of the rear surface.

26. The method according to any one of claims 23 to 25, wherein the method includes progressing a threaded screw within one of the threaded holes for urging against the structure when the mounting is secured to the structure.

27. The mounting according to claim 26, wherein the rear surface of the body includes a further threaded hole for receiving a further threaded screw, wherein the method includes progressing the further threaded screw within the further threaded hole for urging against the structure when the mounting is secured to the structure.

28. A mounting for a glass panel of a glass balustrade arrangement, the mounting including:

a base, the base being of a "U-shaped" configuration so as to have a first and a second flange joined by an end flange, the flanges providing an open cavity within which

- 32 -

the glass panel is to rest so as to be at least partly supported by the mounting with the glass panel generally upwardly oriented, wherein the first and second flanges are generally upright, and said end flange is a bottom flange;

a clamping member adjacent the first flange and located in the cavity;

at least one threaded fastener engaged with said first flange and clamping member to urge the clamping member to engage the glass panel to clamp the glass panel between the second flange and clamping member to fix the glass panel to the mounting; and wherein

the second flange has at least one aperture which at least another threaded fastener engages to fix the mounting to a substantially vertical surface of an edge of a structure such that at least a portion of the glass panel which rests within the cavity overhangs the edge of the structure.

29. The mounting according to claim 28, wherein said second flange has an inner surface to be located adjacent the glass panel, and an outer surface, with each aperture extending between the inner and outer surfaces.

30. The mounting according to claim 29, wherein said inner and outer surfaces are generally upright.

31. The mounting according to any one of claims 28 to 30, wherein the clamping member includes or at least is partially made of a polymer material.

32. The mounting according to any one of claims 28 to 31, wherein each aperture is generally horizontally extending.

33. The mounting according to any one of claims 28 to 32, wherein said cavity is open upwardly.

34. The mounting according to any one of claims 28 to 33, wherein said second flange includes a first flange portion that is generally upwardly oriented, and a second flange

- 33 -

portion extending generally horizontally from the first flange portion, with at least one of the apertures formed in said second flange portion so as to be generally vertically extending.

35. The mounting according to any one of claims 28 to 34, wherein the first flange includes a threaded fastener hole to receive one of the threaded fasteners for urging the clamping member to clamp the glass panel, wherein the threaded fastener hole is coaxial with one of the at least one aperture provided in the second flange.

36. The mounting according to claim 35, wherein one of the at least one aperture in the second flange is configured to receive a threaded screw which is progressed within the respective aperture for urging against the structure when the mounting is secured thereto.

37. The mounting according to claim 36, wherein the second flange includes a further aperture for receiving a threaded screw which is progressed within the further threaded hole for urging against the structure when the mounting is secured thereto.

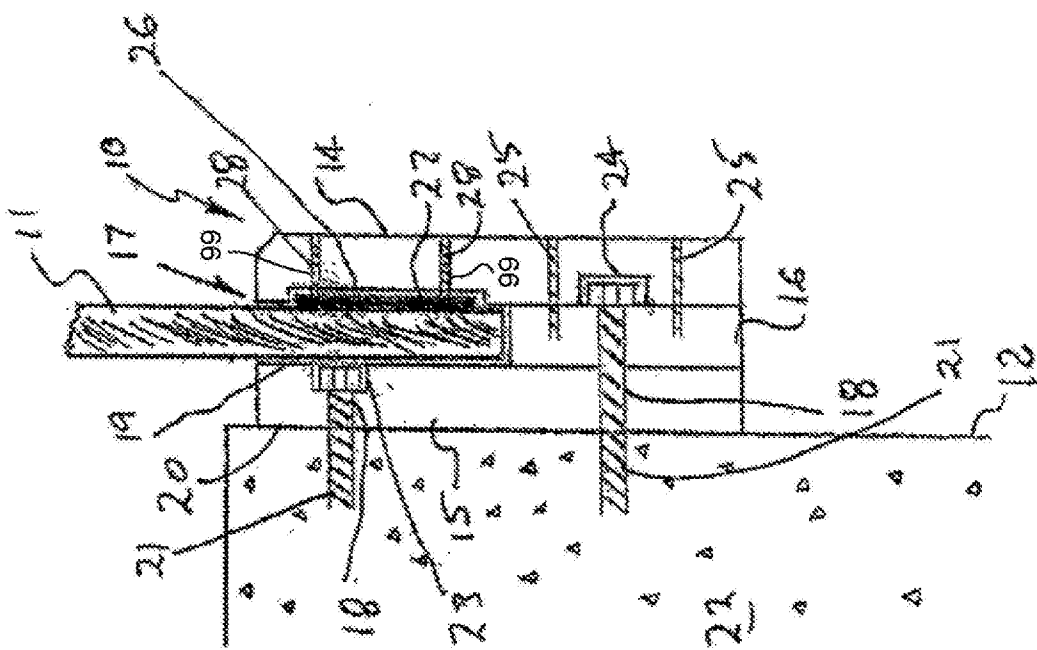

FIGURE 1

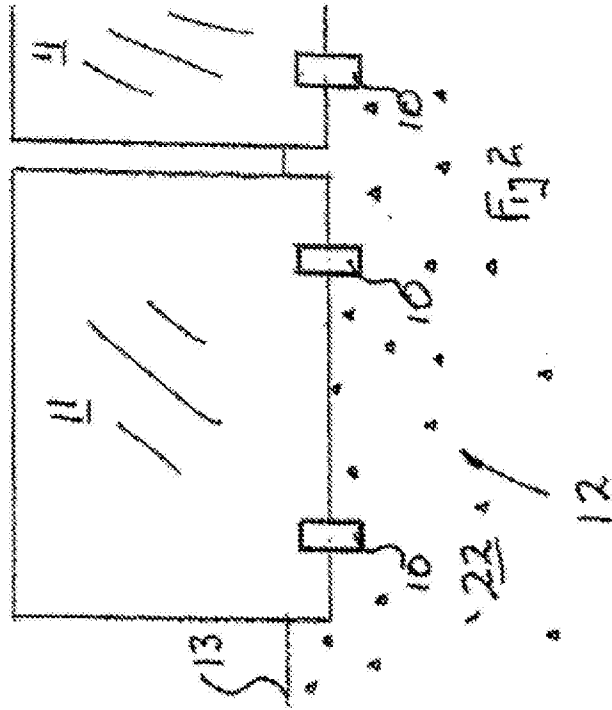

FIGURE 2

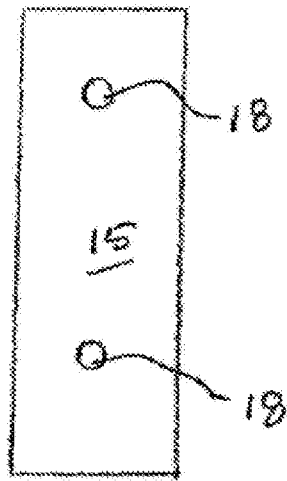

FIGURE 3

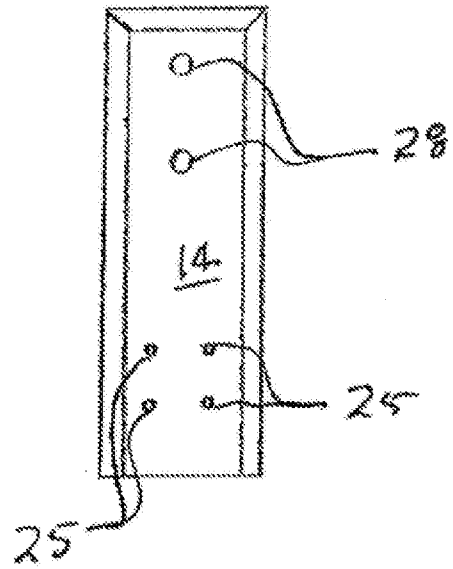

FIGURE 4

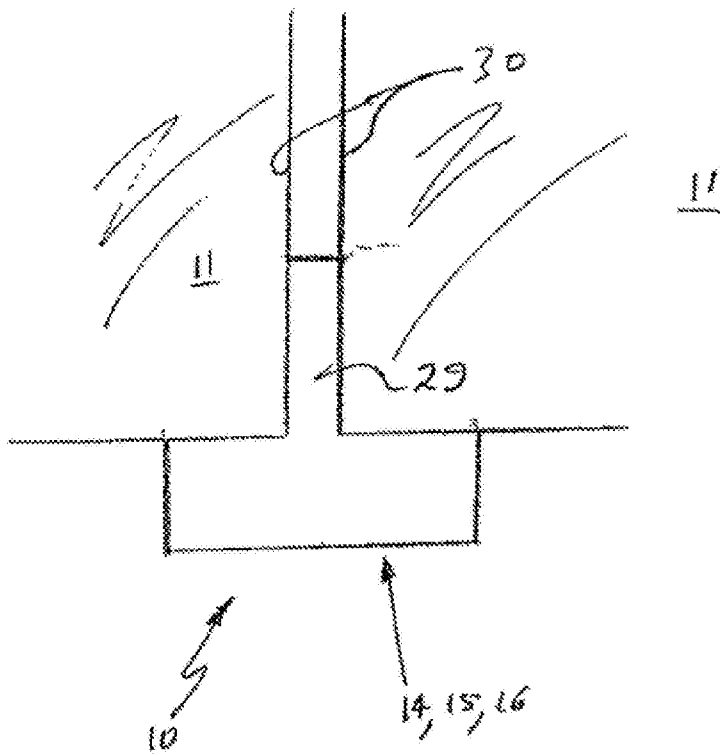

FIGURE 5

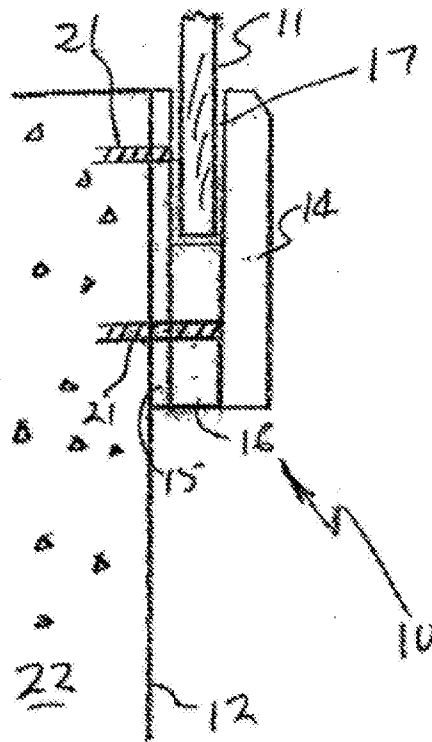

FIGURE 6

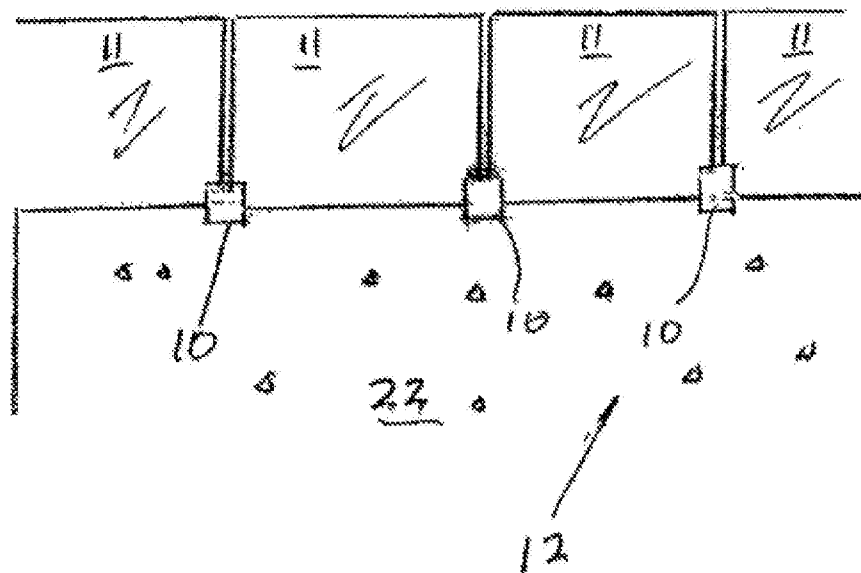

FIGURE 7

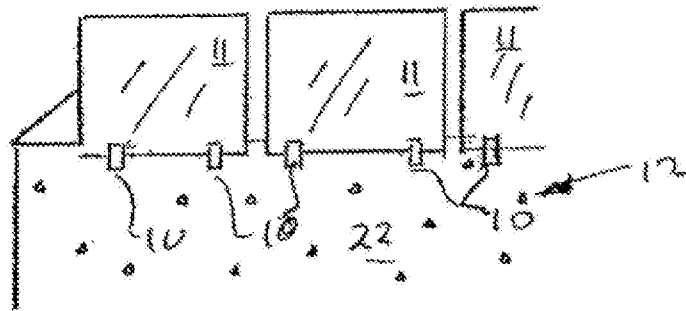

FIGURE 8

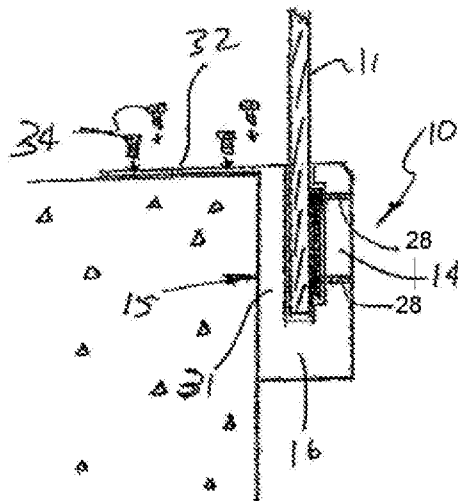

FIGURE 9

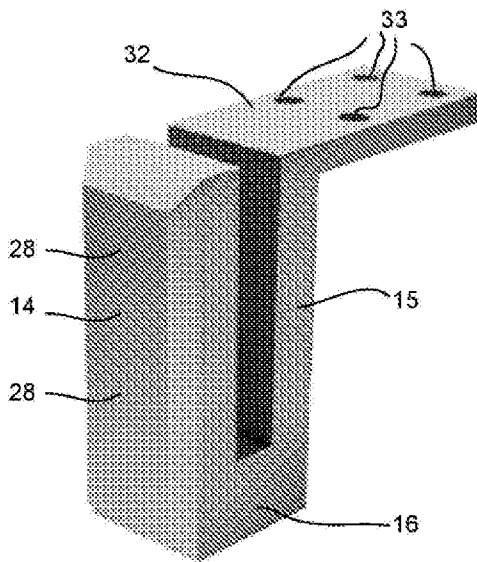

FIGURE 10A

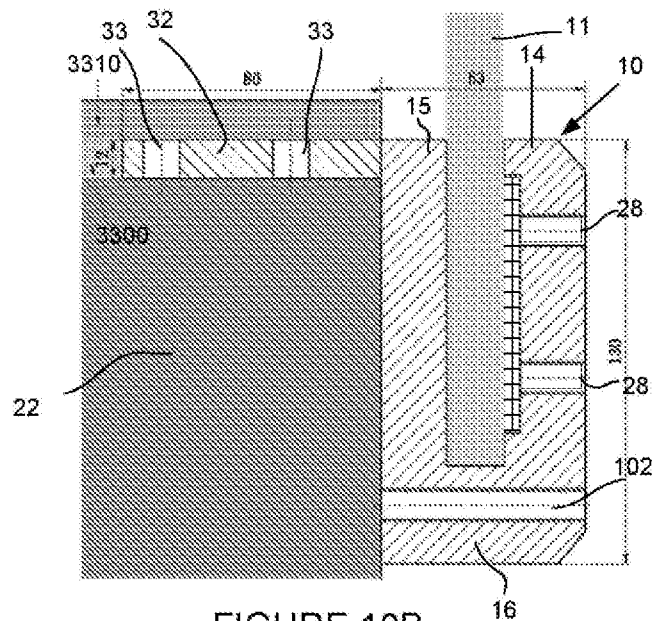

FIGURE 10B

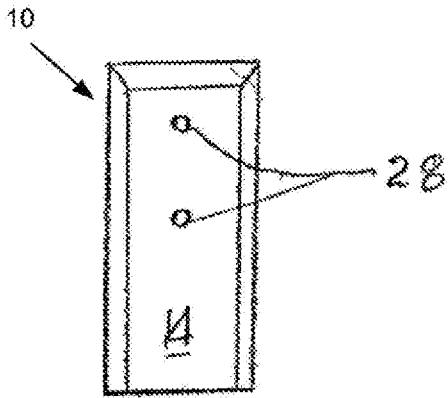

FIGURE 11

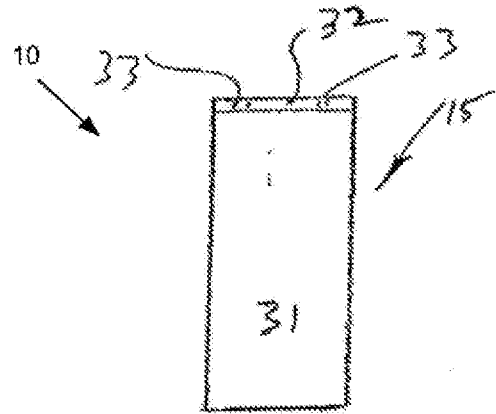

FIGURE 12

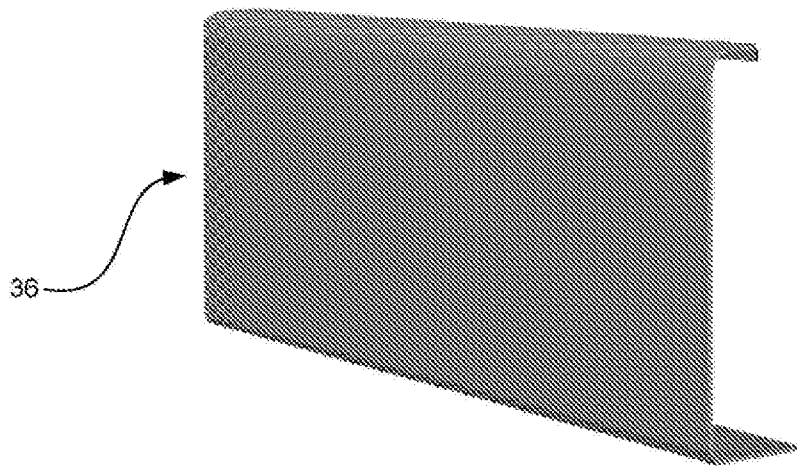

FIGURE 13

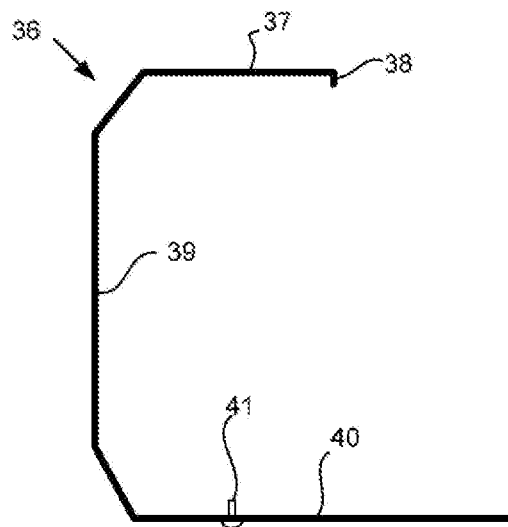

FIGURE 14

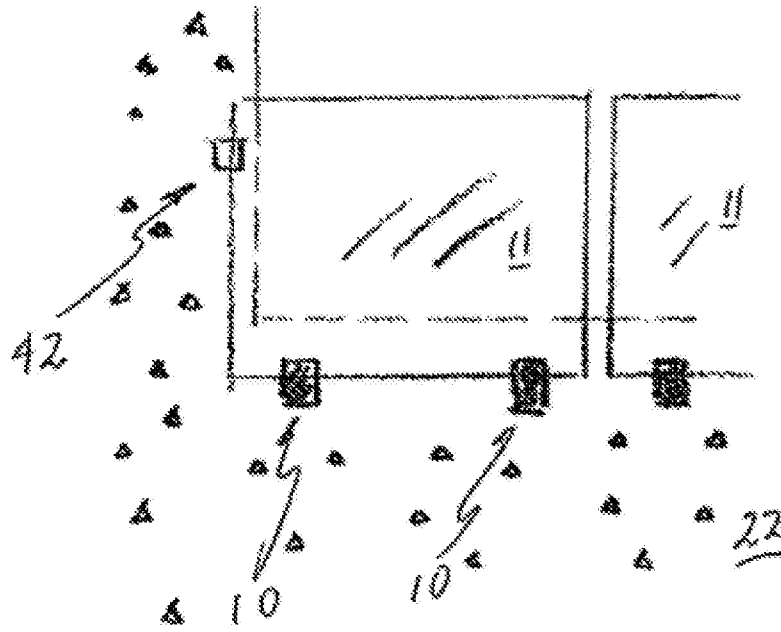

FIGURE 15

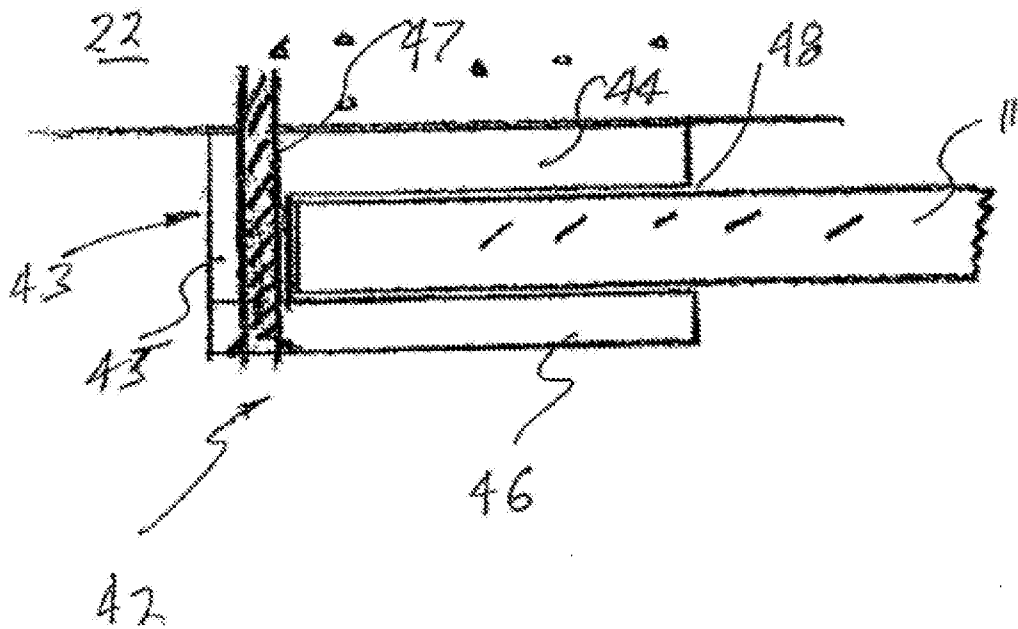

FIGURE 16

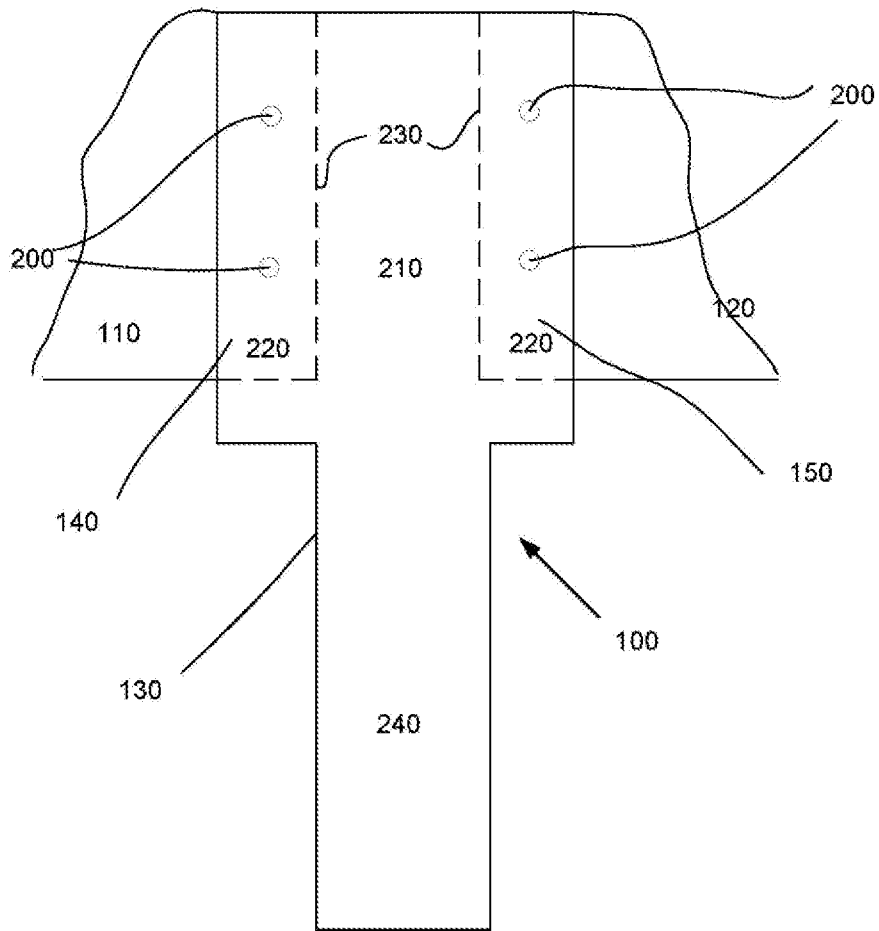

FIGURE 17

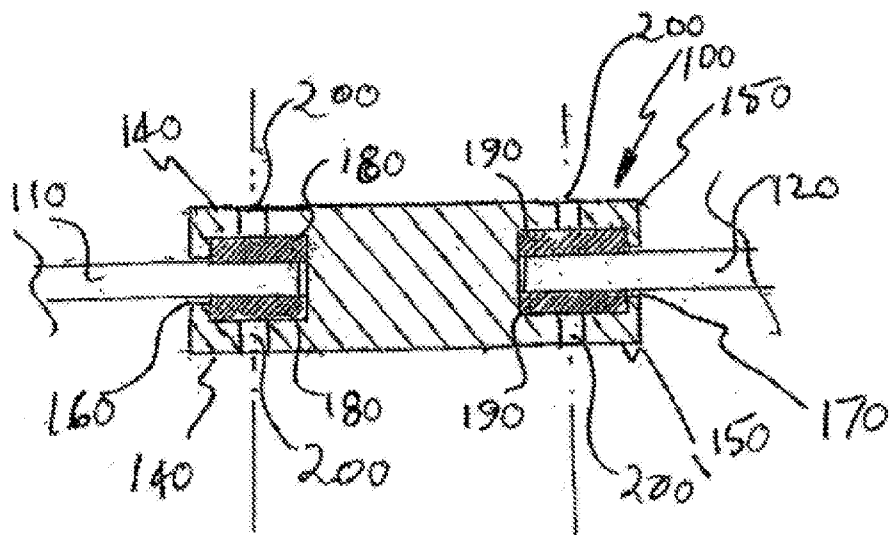

FIGURE 18

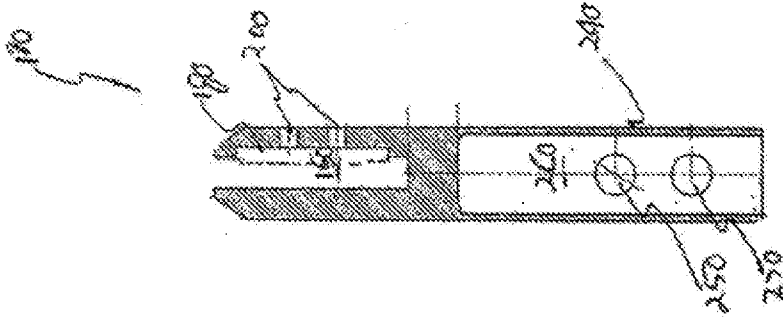

FIGURE 21

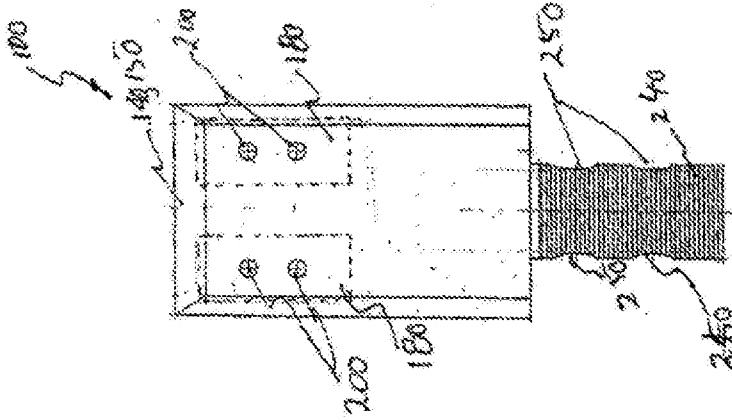

FIGURE 20

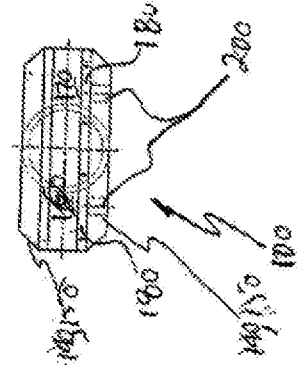

FIGURE 22

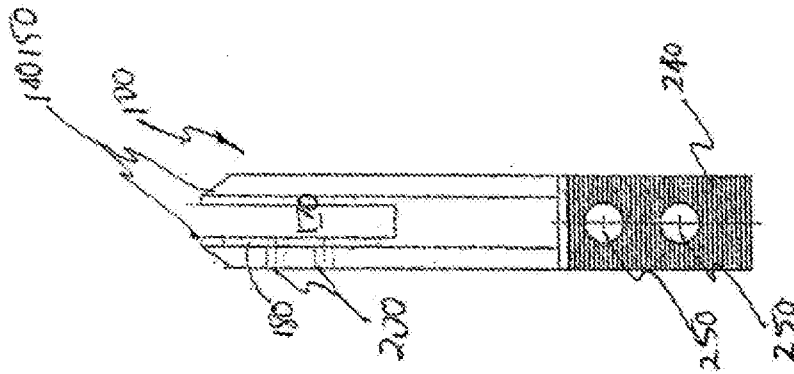

FIGURE 19

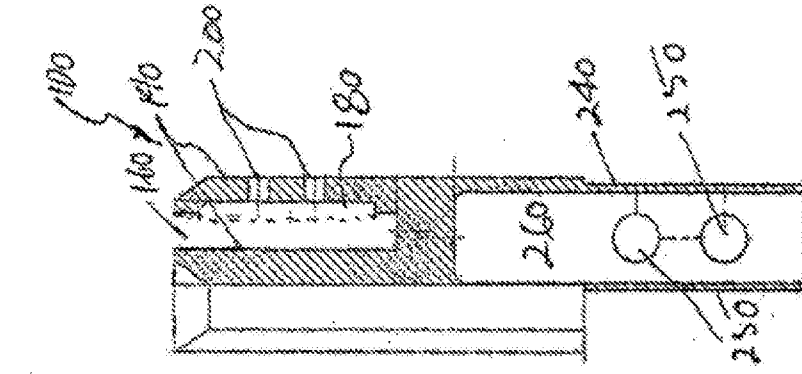

FIGURE 25

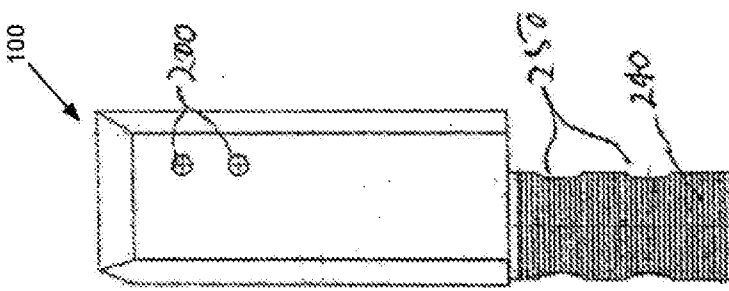

FIGURE 24

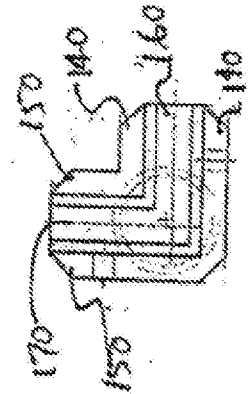

FIGURE 26

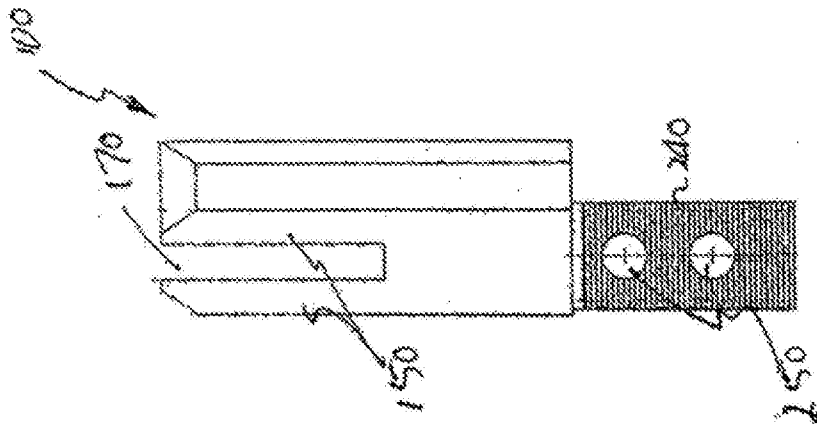
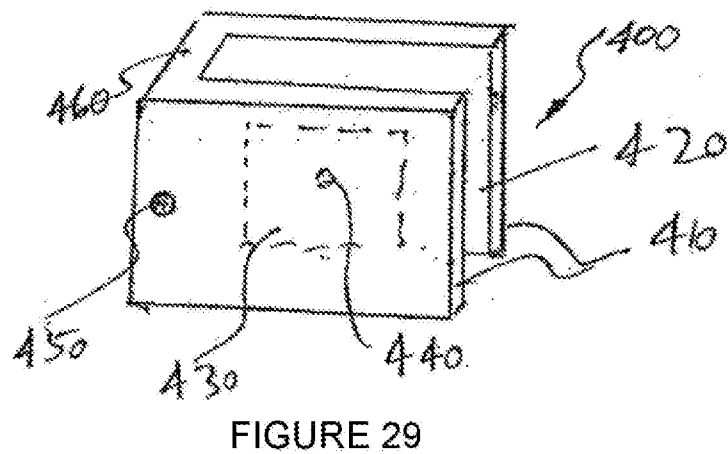
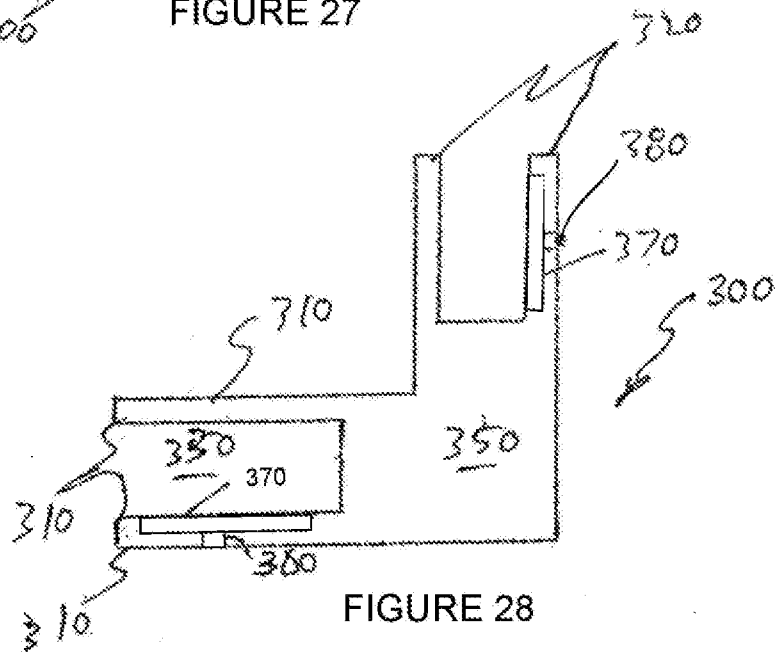
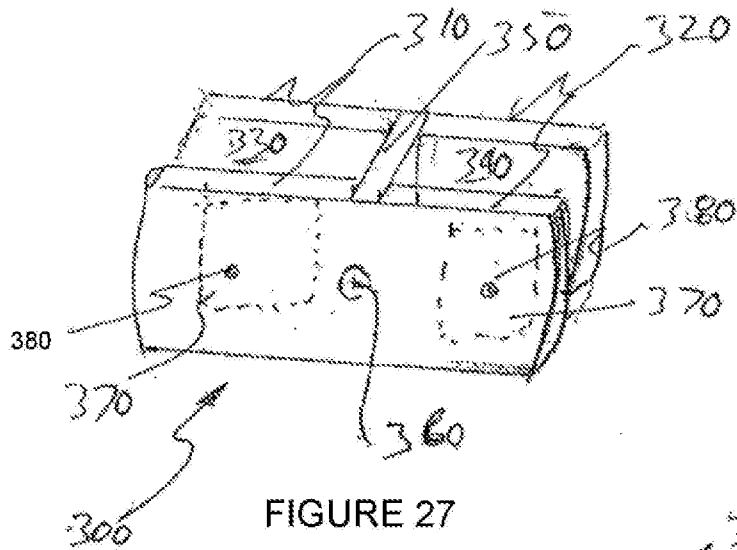

FIGURE 23



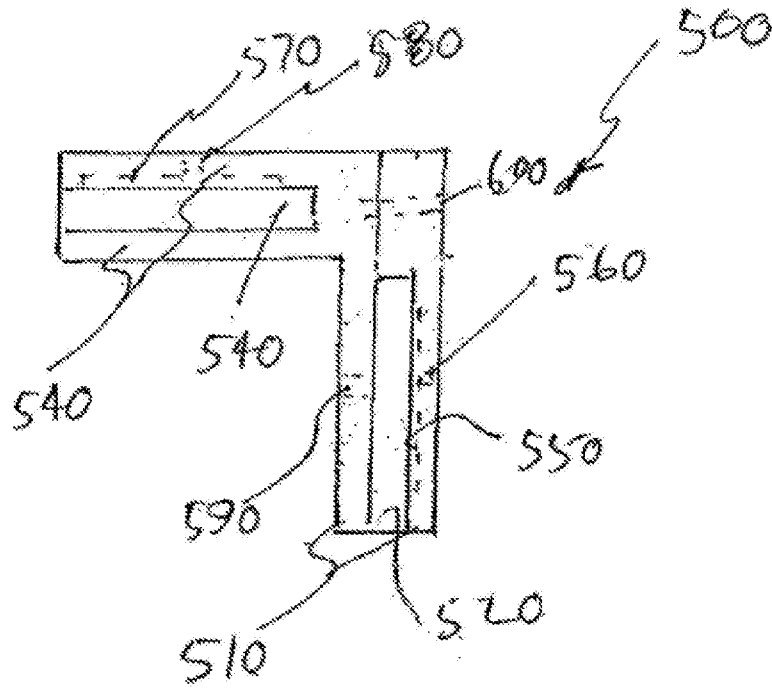

FIGURE 30

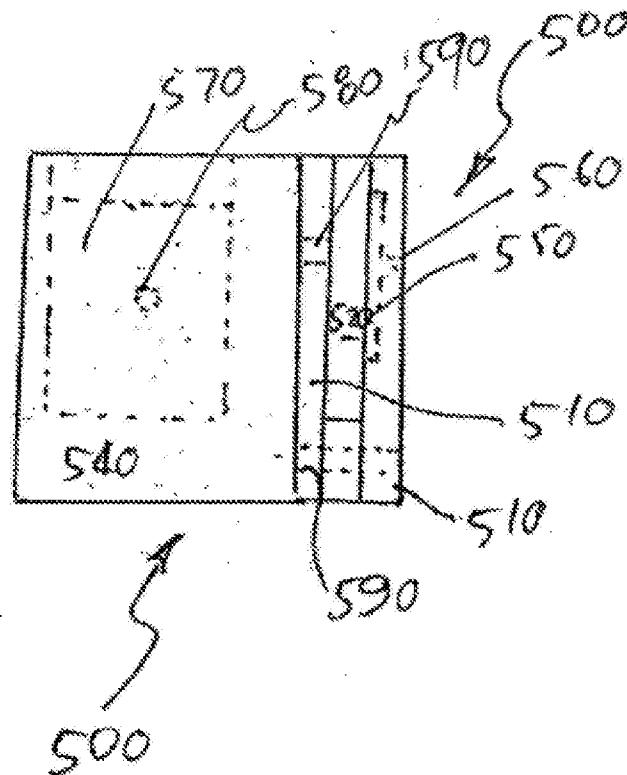

FIGURE 31

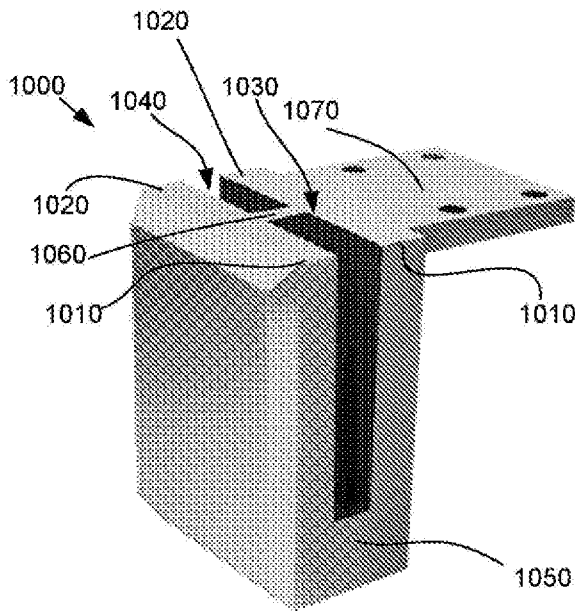

FIGURE 32

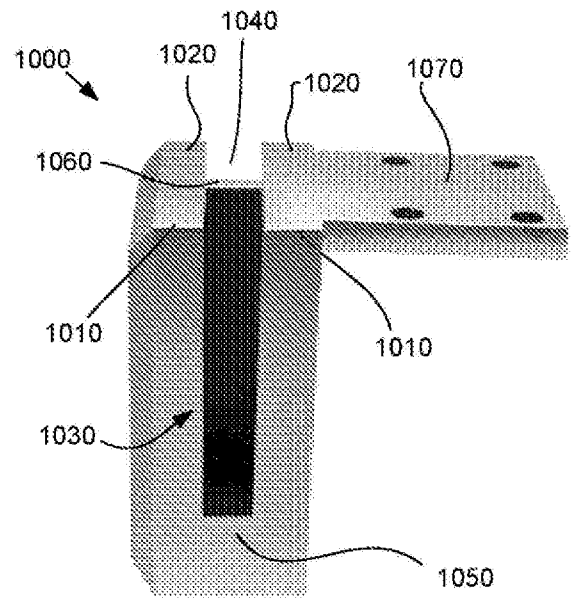

FIGURE 33A

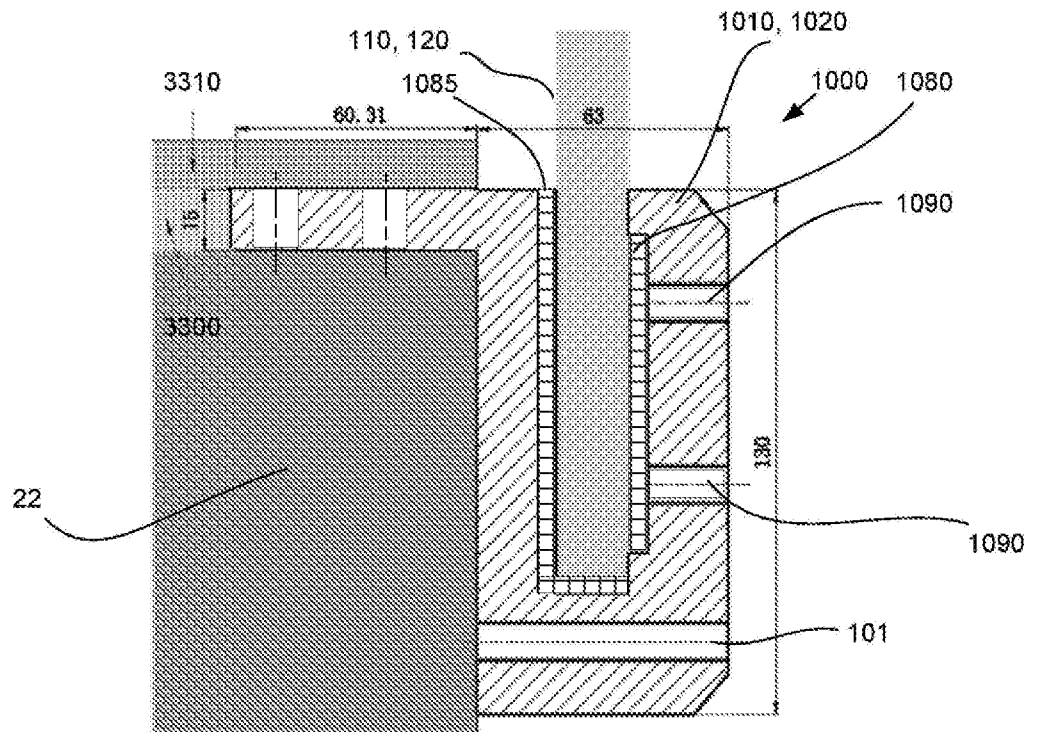

FIGURE 33B

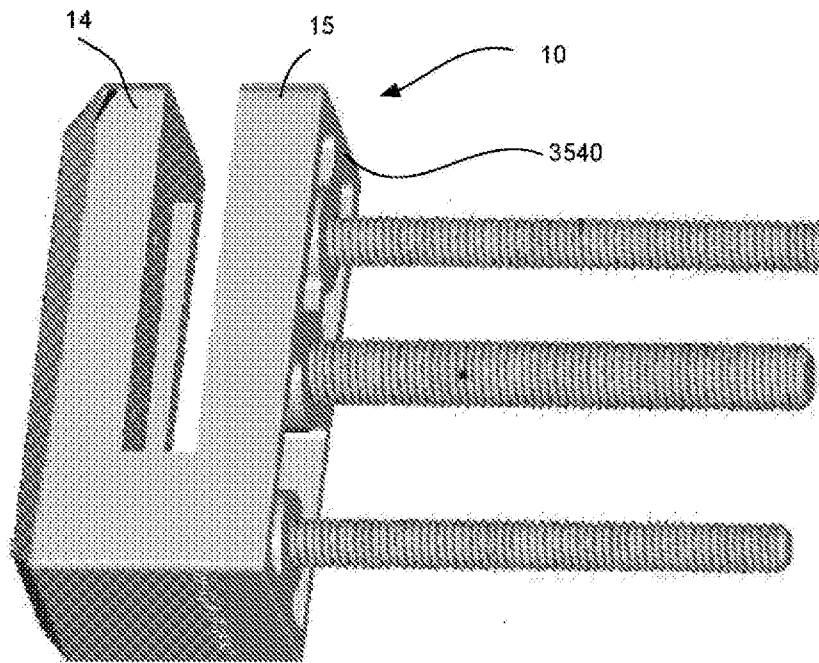

FIGURE 35

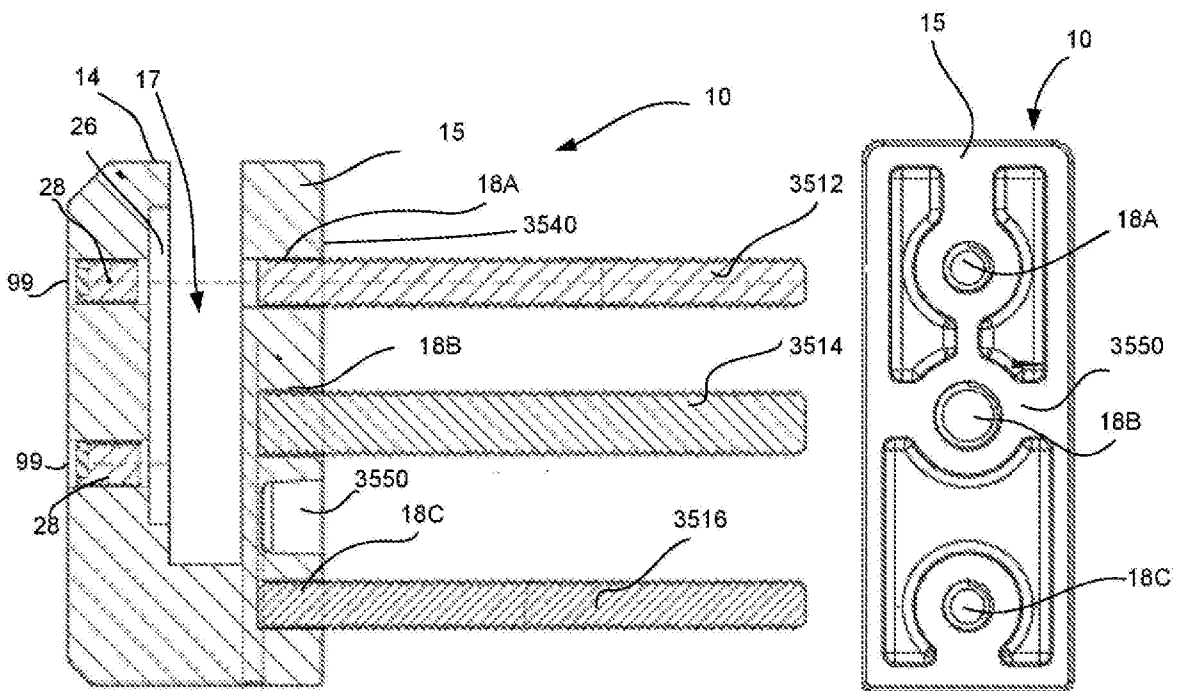

FIGURE 36

FIGURE 37

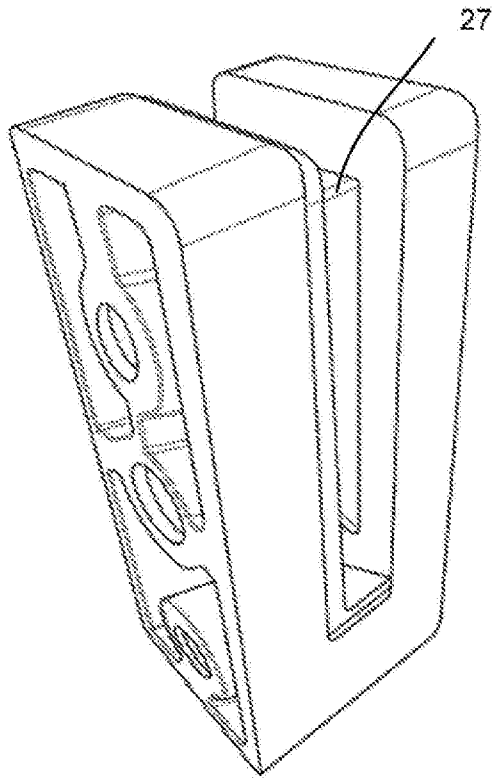

FIGURE 38

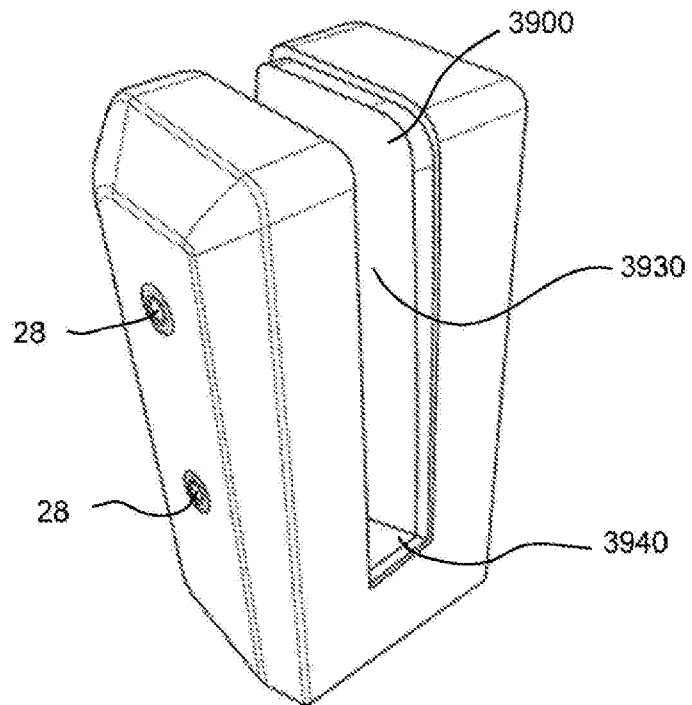

FIGURE 39

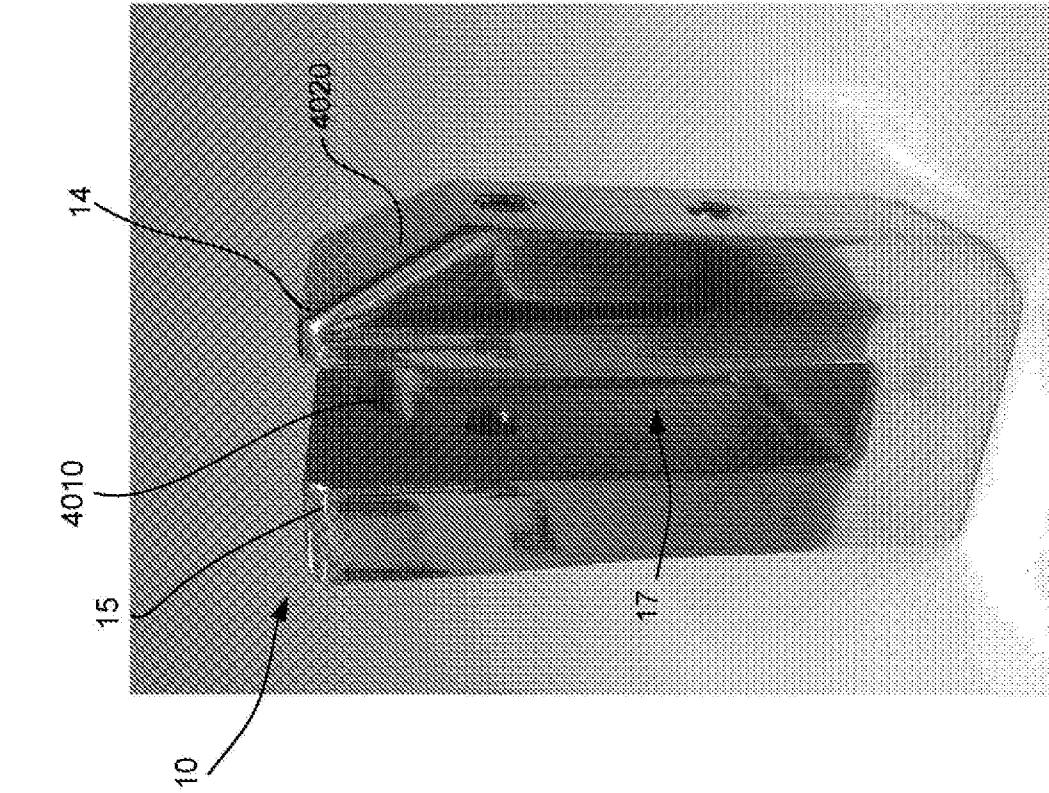

FIGURE 40

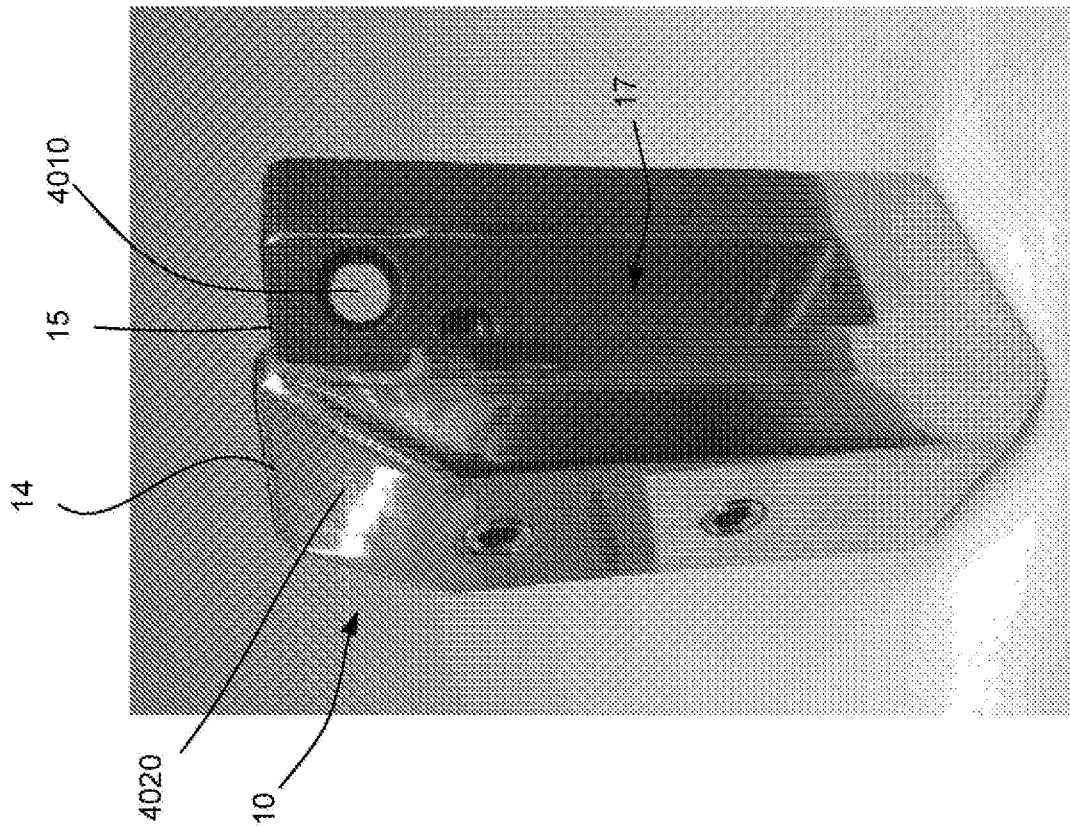

FIGURE 41

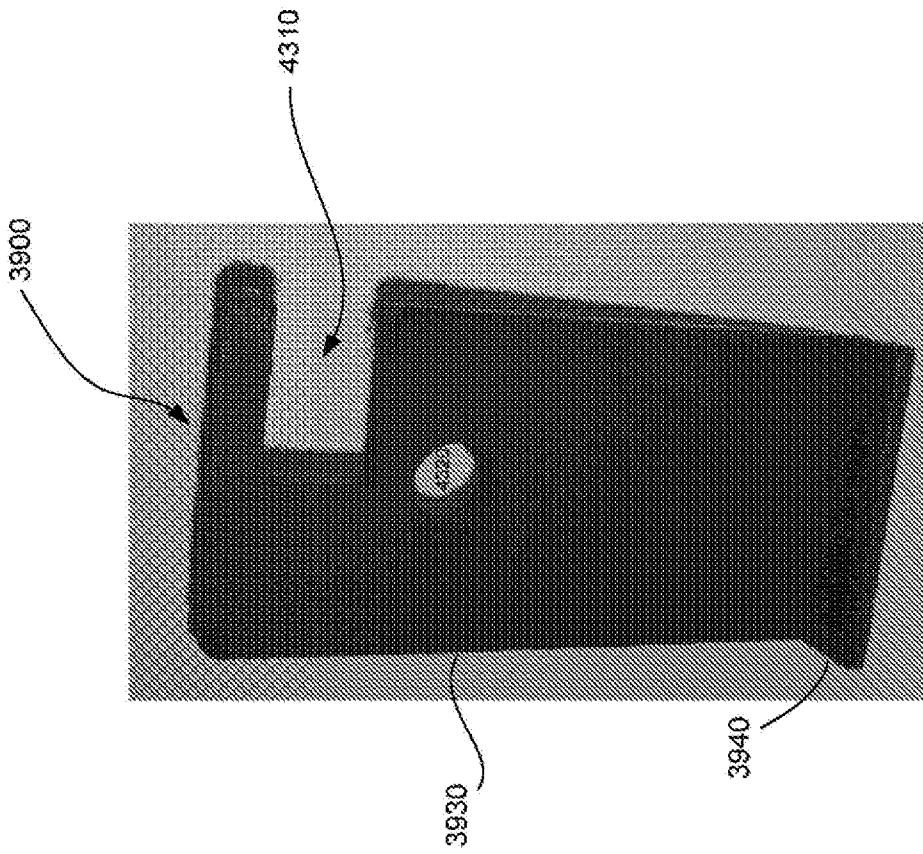

FIGURE 43

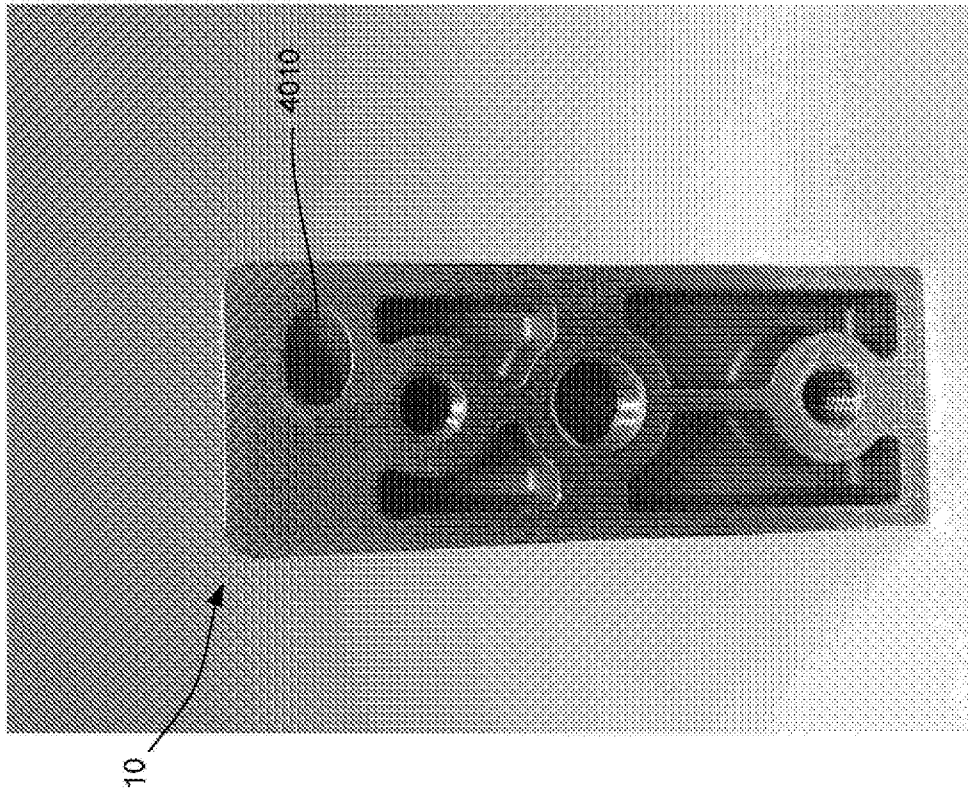

FIGURE 42

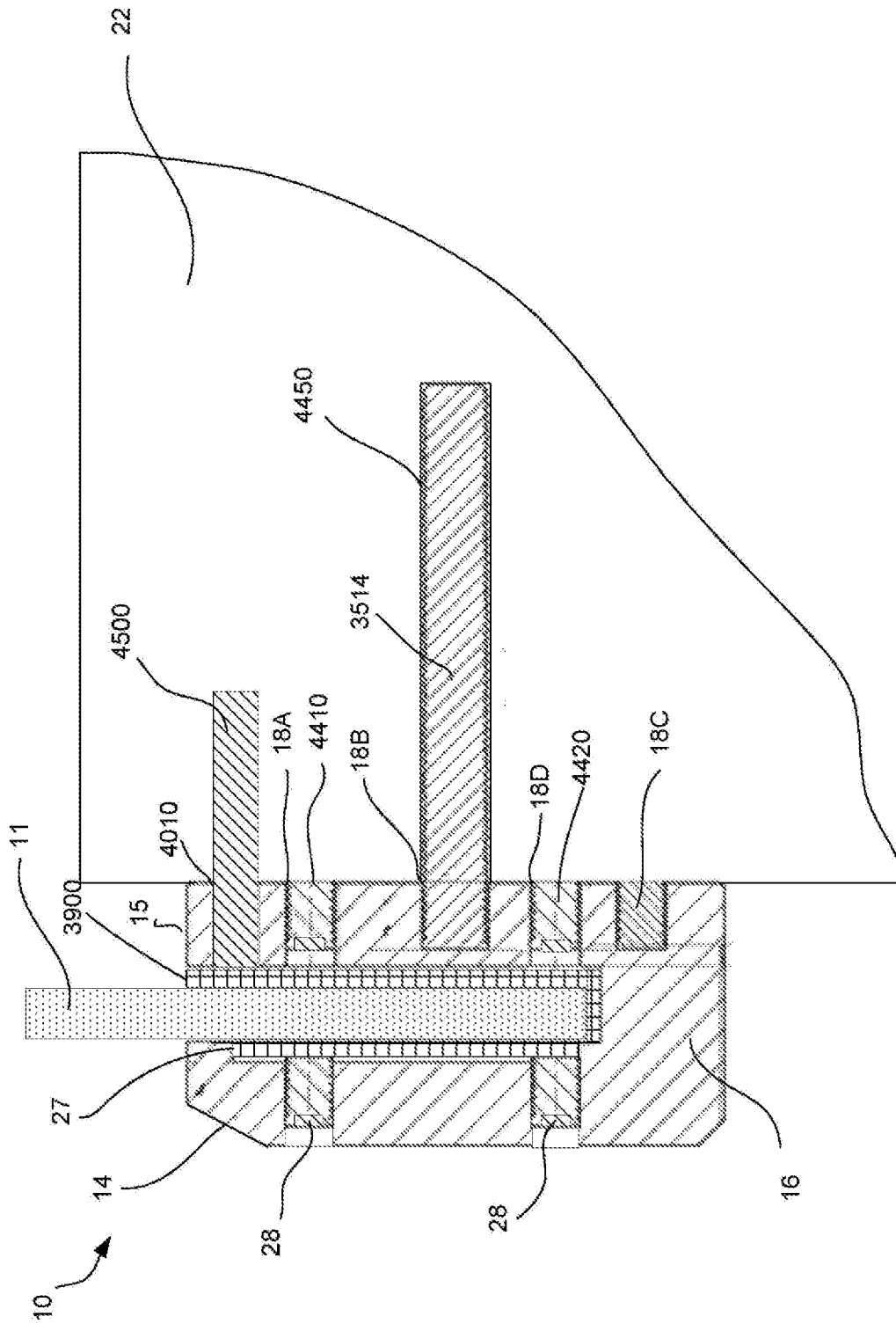

FIGURE 45

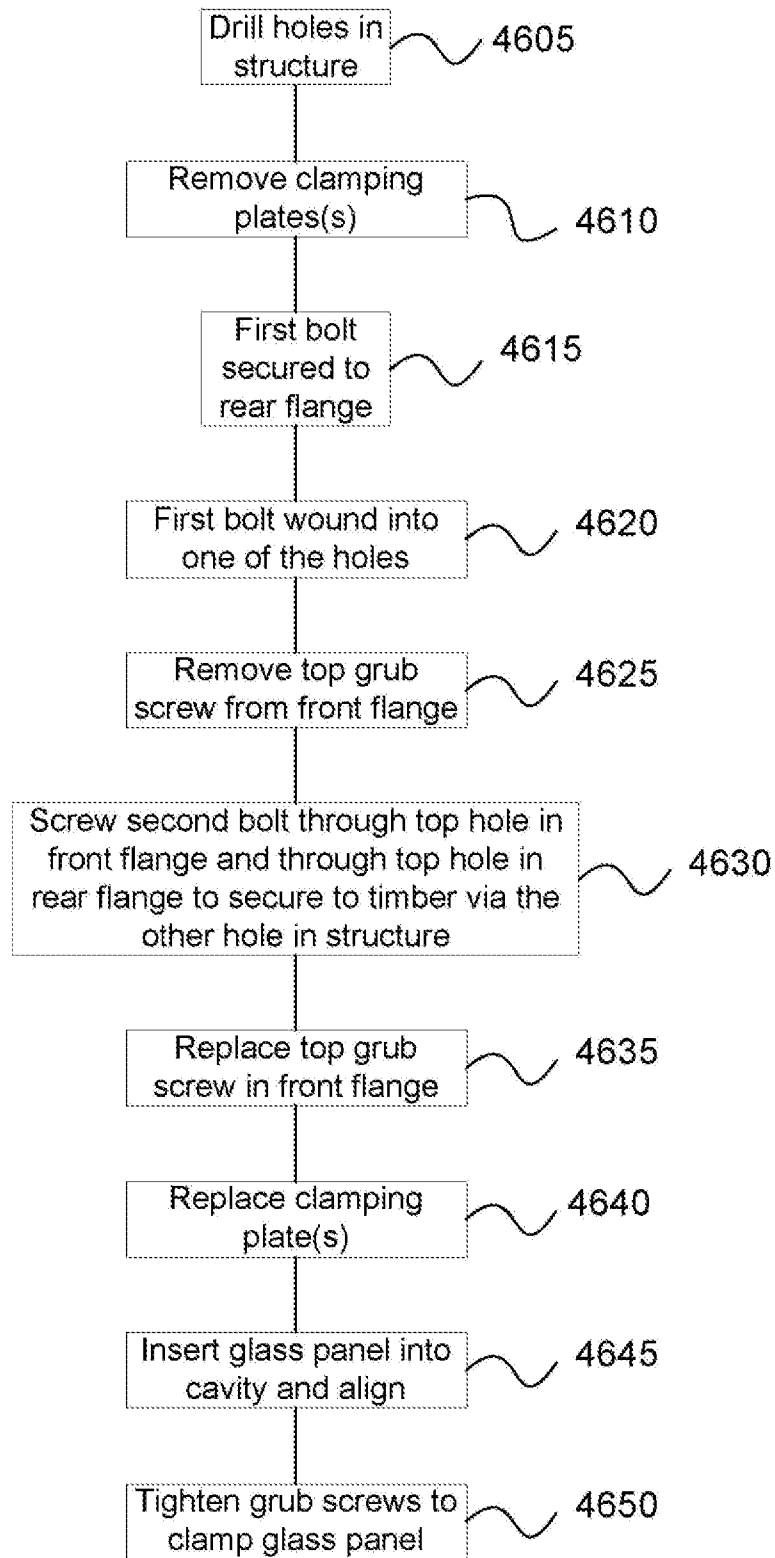

FIGURE 46

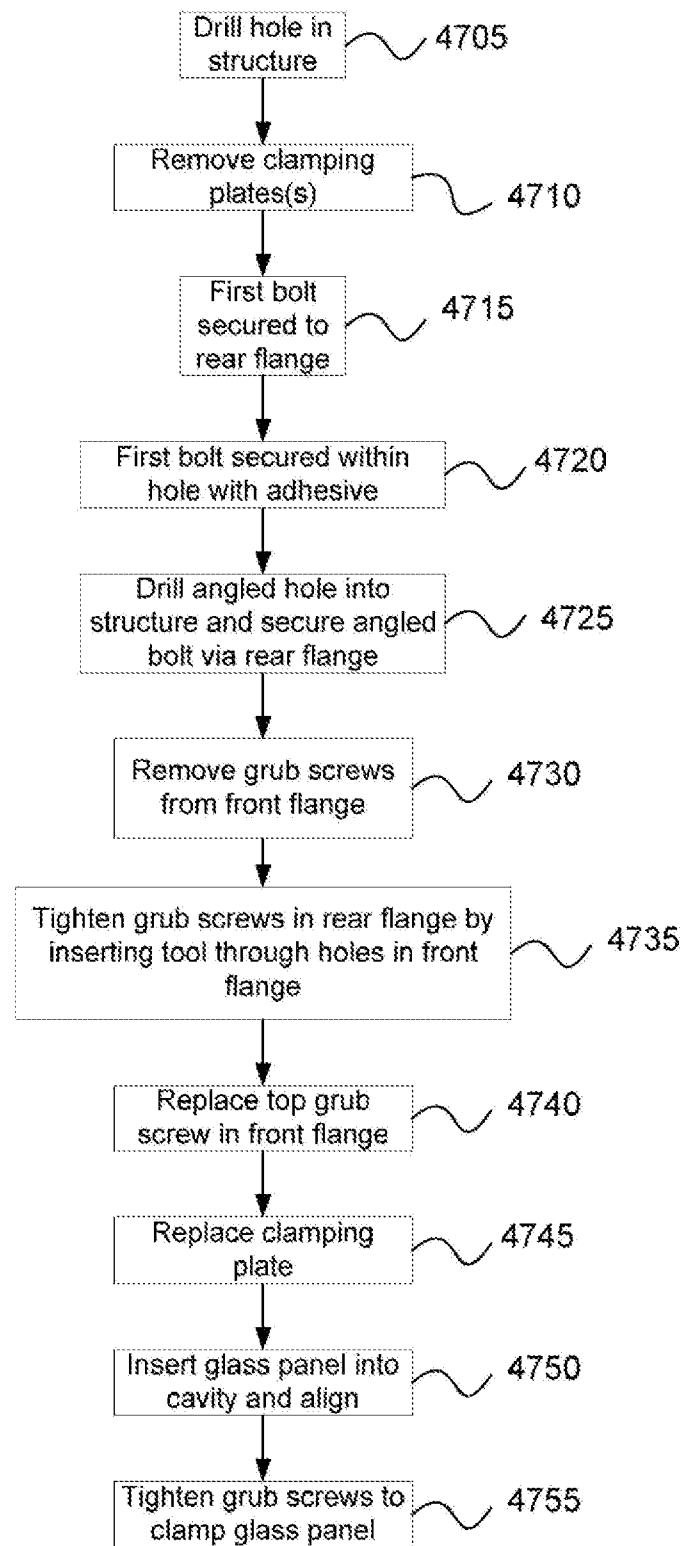

FIGURE 47

INTERNATIONAL SEARCH REPORT

International application No.

PCT/AU2014/050202**A. CLASSIFICATION OF SUBJECT MATTER****E04F 11/18 (2006.01) E04H 17/16 (2006.01)**

According to International Patent Classification (IPC) or to both national classification and IPC

B. FIELDS SEARCHED

Minimum documentation searched (classification system followed by classification symbols)

Documentation searched other than minimum documentation to the extent that such documents are included in the fields searched

Electronic data base consulted during the international search (name of data base and, where practicable, search terms used)

EPODOC, WPI: CPC & IC: E04F11/18, E04B2/72, E04B2/82, E04B2/90/, E04H17/14, : KEYWORDS: (FENCE, BALUSTRADE, PANEL, GLASS, TRANSPARENT, MOUNT, SUPPORT, WALL, EDGE, CLAMP, WEDGE, BOLT, THREAD, U_SHAPE, COAXIAL, INLINE) AND LIKE TERMS: ESPACENET, GOOGLE PATENTS: CPC & IC: E04F11/18, E04B2/72, E04B2/82, E04B2/90/, E04H17/14, : KEYWORDS: (FENCE, BALUSTRADE, PANEL, GLASS, TRANSPARENT, MOUNT, SUPPORT, WALL, EDGE, CLAMP, WEDGE, BOLT, THREAD, U_SHAPE, COAXIAL, INLINE) AND LIKE TERMS IN VARIOUS COMBINATIONS: AUSPAT & GOOGLE PATENTS: APPLICANT/INVENTOR NAME SEARCH

C. DOCUMENTS CONSIDERED TO BE RELEVANT

Category*	Citation of document, with indication, where appropriate, of the relevant passages	Relevant to claim No.
Documents are listed in the continuation of Box C		

 Further documents are listed in the continuation of Box C
 See patent family annex

* Special categories of cited documents:		
"A" document defining the general state of the art which is not considered to be of particular relevance	"T" later document published after the international filing date or priority date and not in conflict with the application but cited to understand the principle or theory underlying the invention	
"E" earlier application or patent but published on or after the international filing date	"X" document of particular relevance; the claimed invention cannot be considered novel or cannot be considered to involve an inventive step when the document is taken alone	
"L" document which may throw doubts on priority claim(s) or which is cited to establish the publication date of another citation or other special reason (as specified)	"Y" document of particular relevance; the claimed invention cannot be considered to involve an inventive step when the document is combined with one or more other such documents, such combination being obvious to a person skilled in the art	
"O" document referring to an oral disclosure, use, exhibition or other means	"&" document member of the same patent family	
"P" document published prior to the international filing date but later than the priority date claimed		

Date of the actual completion of the international search
10 December 2014Date of mailing of the international search report
10 December 2014**Name and mailing address of the ISA/AU**
 AUSTRALIAN PATENT OFFICE
 PO BOX 200, WODEN ACT 2606, AUSTRALIA
 Email address: pct@ipaustalia.gov.au
Authorised officer
 Stefan Ochsenbein
 AUSTRALIAN PATENT OFFICE
 (ISO 9001 Quality Certified Service)
 Telephone No. 0262832269

INTERNATIONAL SEARCH REPORT		International application No.
C (Continuation). DOCUMENTS CONSIDERED TO BE RELEVANT		PCT/AU2014/050202
Category*	Citation of document, with indication, where appropriate, of the relevant passages	Relevant to claim No.
X	WO 2013/064985 A1 (GLASS VICE HOLDINGS LIMITED) 10 May 2013 Fig2,12&24 Itm4,5,16,18,19,10, 11 & 83	1-7 & 28-37
X	NL 7605395 A (SHER) 20 May 1976 Fig1&5 Itm62',68',84,86,64',66'&50'	1-7 & 28-37
A	DE 20111872 U1 (ARNOLD GMBH) 04 October 2001 Fig2&3	1-7 & 28-37
A	US 3630490 A (HORGAN) 28 December 1971 Fig1&2	1-7 & 28-37
A	AU 2012216776 A1 (CSR VIRIDIAN (NZ) LIMITED) 02 May 2013 Fig1	1-7 & 28-37
A	WO 2009/028962 A1 (TROTT) 05 March 2009 Fig1&3c	1-7 & 28-37

Box No. II Observations where certain claims were found unsearchable (Continuation of item 2 of first sheet)

This international search report has not been established in respect of certain claims under Article 17(2)(a) for the following reasons:

1. Claims Nos.:
because they relate to subject matter not required to be searched by this Authority, namely:
the subject matter listed in Rule 39 on which, under Article 17(2)(a)(i), an international search is not required to be carried out, including
2. Claims Nos.: **8-27**
because they relate to parts of the international application that do not comply with the prescribed requirements to such an extent that no meaningful international search can be carried out, specifically:
See Supplemental Box
3. Claims Nos.:
because they are dependent claims and are not drafted in accordance with the second and third sentences of Rule 6.4(a)

Box No. III Observations where unity of invention is lacking (Continuation of item 3 of first sheet)

This International Searching Authority found multiple inventions in this international application, as follows:

1. As all required additional search fees were timely paid by the applicant, this international search report covers all searchable claims.
2. As all searchable claims could be searched without effort justifying additional fees, this Authority did not invite payment of additional fees.
3. As only some of the required additional search fees were timely paid by the applicant, this international search report covers only those claims for which fees were paid, specifically claims Nos.:
4. No required additional search fees were timely paid by the applicant. Consequently, this international search report is restricted to the invention first mentioned in the claims; it is covered by claims Nos.:

Remark on Protest

- The additional search fees were accompanied by the applicant's protest and, where applicable, the payment of a protest fee.
- The additional search fees were accompanied by the applicant's protest but the applicable protest fee was not paid within the time limit specified in the invitation.
- No protest accompanied the payment of additional search fees.

Supplemental Box**Continuation of Box II**

Claim 8 when appended to claim 1 is so inadequately supported by the description that no meaningful opinion (or search) could be formed. The method of claim 1 for securing a mounting to a structure for a glass balustrade cannot be used to secure the mounting of claim 8 because the mounting of claim 8 has different features. In referring to the specification as a whole no mounting can be found that has the features of claim 8 that can be secured using the method of claim 1. The mounting of claim 8 is clearly not intended to be mounted to structure in the manner claimed. A mounting suitable to be mounted by the method claim 1 is featured in claim 28 and therefore it is not obvious how claim 8 can be amended so that it can be mounted using the method of claim 1 without having the same features as those of claim 28. Claims 9-27 are appended to claim 8 and therefore are also inadequately supported by the description and therefor no search and opinion has been performed on these claims. Therefore a search and the opinion has not been established for claims 8-27.

INTERNATIONAL SEARCH REPORT

Information on patent family members

International application No.

PCT/AU2014/050202

This Annex lists known patent family members relating to the patent documents cited in the above-mentioned international search report. The Australian Patent Office is in no way liable for these particulars which are merely given for the purpose of information.

Patent Document/s Cited in Search Report		Patent Family Member/s	
Publication Number	Publication Date	Publication Number	Publication Date
WO 2013/064985 A1	10 May 2013	AU 2012330800 A1	19 Jun 2014
		GB 2511954 A	17 Sep 2014
		NZ 596115 A	30 May 2014
		US 2014334874 A1	13 Nov 2014
NL 7605395 A	20 May 1976	US 4054268 A	18 Oct 1977
DE 20111872 U1	04 October 2001	EP 1277894 B1	14 Nov 2007
US 3630490 A	28 December 1971		
AU 2012216776 A1	02 May 2013	NZ 595645 A	28 Mar 2014
WO 2009/028962 A1	05 March 2009	AU 2008293132 A1	05 Mar 2009
		AU 2008293132 B2	23 Jun 2011
		NZ 561106 A	28 Nov 2008

End of Annex

Due to data integration issues this family listing may not include 10 digit Australian applications filed since May 2001.

Form PCT/ISA/210 (Family Annex)(July 2009)