



- (51) International Patent Classification: *A61B 17/17* (2006.01)
- (21) International Application Number: PCT/US2009/036661
- (22) International Filing Date: 10 March 2009 (10.03.2009)
- (25) Filing Language: English
- (26) Publication Language: English
- (30) Priority Data: 12/045,416 10 March 2008 (10.03.2008) US
- (71) Applicant (for all designated States except US): **ZIMMER ORTHOBIOLOGICS, INC.** [US/US]; 9301 Amberglenn Blvd., Bldg. J, Suite 100, Austin, TX 78729 (US).
- (72) Inventors; and
- (75) Inventors/Applicants (for US only): **RITTER, Robin** [US/US]; 1408 Dove Hill Drive, Cedar Park, TX 78613 (US). **ZAPOROJAN, Victor** [MD/US]; 5910 Avery Island Avenue, Austin, TX 78727 (US). **GAO, Jizong** [CN/US]; 1400 Old Mill Road, Cedar Park, TX 78613 (US).
- (74) Agents: **SCHWALLER, Melissa, D.** et al.; Howrey LLP, 2941 Fairview Park Dr., Suite 200, Falls Church, VA 22042 (US).
- (81) Designated States (unless otherwise indicated, for every kind of national protection available): AE, AG, AL, AM, AO, AT, AU, AZ, BA, BB, BG, BH, BR, BW, BY, BZ, CA, CH, CN, CO, CR, CU, CZ, DE, DK, DM, DO, DZ, EC, EE, EG, ES, FI, GB, GD, GE, GH, GM, GT, HN, HR, HU, ID, IL, IN, IS, JP, KE, KG, KM, KN, KP, KR, KZ, LA, LC, LK, LR, LS, LT, LU, LY, MA, MD, ME, MG, MK, MN, MW, MX, MY, MZ, NA, NG, NI, NO, NZ, OM, PG, PH, PL, PT, RO, RS, RU, SC, SD, SE, SG, SK, SL, SM, ST, SV, SY, TJ, TM, TN, TR, TT, TZ, UA, UG, US, UZ, VC, VN, ZA, ZM, ZW.
- (84) Designated States (unless otherwise indicated, for every kind of regional protection available): ARIPO (BW, GH, GM, KE, LS, MW, MZ, NA, SD, SL, SZ, TZ, UG, ZM, ZW), Eurasian (AM, AZ, BY, KG, KZ, MD, RU, TJ, TM), European (AT, BE, BG, CH, CY, CZ, DE, DK, EE, ES, FI, FR, GB, GR, HR, HU, IE, IS, IT, LT, LU, LV, MC, MK, MT, NL, NO, PL, PT, RO, SE, SI, SK, TR), OAPI (BF, BJ, CF, CG, CI, CM, GA, GN, GQ, GW, ML, MR, NE, SN, TD, TG).

[Continued on next page]

(54) Title: INSTRUMENTS AND METHODS USED WHEN REPAIRING A DEFECT ON A TISSUE SURFACE

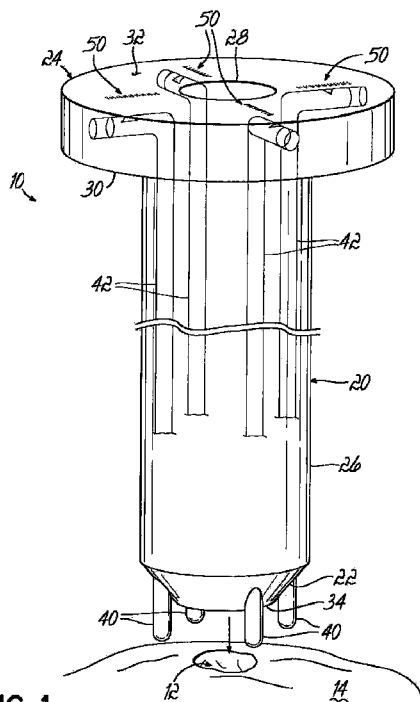

FIG. 1

(57) Abstract: An instrument (10) for determining the proper orientation for repairing a defect site (12) on a tissue surface (14) generally comprises a shaft (20), a plurality of probes (40) operatively coupled to the shaft (20), and at least one indicator (50) operatively coupled to the plurality of probes (40). The probes (40) are configured to extend beyond a first end of the shaft (22) and are movable relative to the shaft (20). The at least one indicator (50) is configured to display the displacements of the probes (40) relative to the first end (22) so that the displacements of the probes (40) may be compared. A method of using the instrument (10) when repairing a defect on a tissue surface (14) is also disclosed.

WO 2009/114524 A1

Published:

— *with international search report (Art. 21(3))*

INSTRUMENTS AND METHODS USED WHEN REPAIRING A DEFECT ON A TISSUE SURFACE

Technical Field

[0001] This invention relates to medical devices and methods, and more particularly to medical instruments and methods used when repairing defects on a tissue surface such as bone or cartilage.

Background

[0002] Medical implants are often delivered to anatomical sites within a patient's body to treat focal defects. For example, damaged cartilage or bone within a patient's body may include a cavity or void formed by trauma, disease, or surgery. The cavity or void may leave the bone prone to further injury or damage, especially when the cavity or void is formed in a weight-bearing joint such as the knee. To treat such a defect, the affected tissue may be drilled out or otherwise prepared to receive an implant designed to promote tissue formation. The implant may comprise healthy cartilage and/or bone cut from other locations on the patient's body, tissue(s) harvested from a donor, and/or synthetic material(s) such as porous ceramics or metals, biocompatible polymers, or combinations thereof.

[0003] Preparing a defect to receive an implant can be a challenging task. Ideally, the defect should be prepared to a size and shape corresponding to that of the implant. This includes not only the dimensions of the prepared cavity, but also its orientation relative to the surrounding tissue surface. For example, bone plugs and similar implants are often cut from bone at angles substantially perpendicular to the surface of the bone. If such a bone plug is delivered into a cavity drilled at an angle to the surrounding surface, the end of the bone plug may not properly correspond to the surrounding surface. Portions of the bone plug may extend out of the cavity (i.e., be "proud") so as to create an undesirable protrusion relative to the surrounding surface. Alternatively or additionally, portions of the bone plug may be recessed relative to the surrounding surface such that a defect in the bone remains.

[0004] Conventional techniques for properly orienting an instrument, such as a cutting tool, relative to a tissue surface rely solely upon visual and/or tactile feedback. After placing the cutting tool in contact with the tissue surface, a surgeon may simply change the angle of the cutting tool until she believes it looks or feels perpendicular to the tissue surface. The surgeon then attempts to maintain this orientation throughout the procedure. As can be appreciated, such

techniques involve a great degree of approximation and may still result in cavities with undesirable orientations. Moreover, oftentimes the surgeon cannot directly view the tissue surface (e.g., because the procedure is performed arthroscopically). Attempting to properly orient a cutting tool while looking through an arthroscope can be even more challenging due to the magnification of the arthroscope.

[0005] As a result, various devices have been developed to facilitate preparing a defect to receive an implant. For example, U.S. Patent No. 5,885,293 to McDevitt discloses a tool for cutting bone surfaces at perpendicular angles. The tool includes a cylindrical bone cutter, a cylindrical housing mounted on a handle of the bone cutter, a probe that slides within an inner bore of the bone cutter and the housing, and a ring on the exterior of the housing connected to the probe by a pin extending through the housing. The probe is biased to normally extend beyond the end of the bone cutter. When the bone cutter is placed against a bone surface, the probe is displaced into the inner bore. This displacement causes the ring to slide along the exterior of the housing, which includes indicia so that the displacement of the probe may be viewed. A surgeon manipulates the tool until maximum displacement is achieved, which, according to McDevitt, which generally corresponds to perpendicular alignment.

[0006] Although McDevitt offers an alternative to conventional techniques for orienting a tool relative to a bone surface, there remains room for improvement. The maximum displacement of a single probe may not always provide a reliable indication of perpendicular alignment. This is particularly true when using the tool disclosed in McDevitt to determine the proper orientation for repairing a defect on a tissue surface. For example, because the probe is a cylindrical element that slides along the center axis of the bone cutter, the probe is likely to contact the cavity defining the defect when the bone cutter is brought into contact with the bone surface. The maximum displacement of the probe found after manipulating the bone cutter may not necessarily reflect perpendicular alignment due to the differences (e.g. irregularities) between the defect and the profile of the surrounding surface.

[0007] Accordingly, an improved instrument to determine the proper orientation for repairing a defect on a tissue surface would be highly desirable.

Summary

[0008] Medical instruments and methods used when repairing defects on a tissue surface are described below. The instruments and methods are particularly suited to facilitate repairing defects on irregular surfaces (e.g., multi-radii, articular, and similar surfaces), although the instruments and methods may also be used in connection with other tissue surfaces. Additionally, the instruments may serve a variety purposes. The instruments described below may be used, for example, as an implant delivery device, punch, drill, guide tube, tamp, sleeve, obturator, cutting device, or some combination thereof.

[0009] In one embodiment, an instrument for determining the proper orientation for repairing a defect site on a tissue surface generally comprises a shaft, a plurality of probes operatively coupled to the shaft, and at least one indicator operatively coupled to the plurality of probes. The shaft includes a first end configured to contact the tissue surface and a second end opposite the first end. Each of the probes is moveable relative to the shaft and configured to extend beyond the first end. Because the indicator is configured to display the displacements of the probes relative to the first end, the displacements of the probes may be compared. There may be a single indicator or a plurality of indicators corresponding to the plurality of probes.

[0010] In another embodiment, the instrument is provided as part of an assembly that further includes a defect preparation tool. The shaft in such an embodiment may be a cannula defined by an outer wall surrounding a central bore. The defect preparation tool, which may be inserted through the central bore, is configured to prepare the defect site for receiving an implant. Alternatively or additionally, the implant may be provided as part of the assembly. The implant is configured to be received within the central bore of the shaft and is delivered to the defect site through the central bore.

[0011] One method of using the type of instrument described above generally comprises positioning the instrument proximate to a patient's body and contacting the tissue surface with the first end of the shaft and the plurality of probes. The displacement of each probe relative to the first end is transmitted to the at least one indicator. A user then determines the angle of the shaft relative to the tissue surface based on displacement information displayed or otherwise communicated by the at least one indicator. If necessary, the user adjusts the angle of the shaft relative to the tissue surface until a desired orientation is achieved.

[0012] When there is a plurality of indicators each configured to display the displacement information of one of the probes, the angle of the shaft may be determined by viewing the displacement information of each probe. After comparing the displacement information of at least two of the probes, the angle of the shaft may be adjusted until the displacements of the at least two probes are substantially equal.

[0013] In another embodiment, the method may further comprise substantially maintaining the shaft at a desired angle (e.g., 90°) relative to the tissue surface. The shaft may be a cannula defined by an outer wall surrounding a central bore. After inserting a defect preparation tool through the central bore, the defect site on the tissue surface is prepared to receive an implant. To this end, the defect preparation tool may be subsequently removed from the shaft so that the implant may be inserted into the central bore and delivered to the defect site through the shaft.

Brief Description of the Drawings

[0014] Fig. 1 is a perspective view showing one embodiment of an instrument for determining the proper orientation for repairing a defect site on a tissue surface.

[0015] Fig. 2 is top view of the instrument shown in Fig. 1.

[0016] Fig. 3 is a cross-sectional view of a portion of an instrument according to an embodiment in which the displacement of a probe is hydraulically communicated to an indicator.

[0017] Fig. 3A is a top view taken along line 3A-3A showing a portion of the instrument of Fig. 3.

[0018] Fig. 4 is a cross-sectional view similar to Fig. 3, but showing a portion of an instrument according to an embodiment in which the displacement of a probe is mechanically communicated to an indicator.

[0019] Fig. 4A is a top view taken along line 4A-4A showing a portion of the instrument of Fig. 4.

[0020] Fig. 5 is a cross-sectional view similar to Fig. 3, but showing a portion of an instrument according to another embodiment in which the displacement of the probe is mechanically communicated to the indicator.

[0021] Fig. 5A is a top view taken along line 5A-5A showing a portion of the instrument of Fig. 5.

[0022] Fig. 6 is a perspective view, partially in cross-section, showing an instrument according to an embodiment in which the displacement of a probe is electrically communicated to an indicator.

[0023] Fig. 7 is a perspective view of a portion of an instrument according to another embodiment in which the displacement of a probe is electrically communicated to an indicator.

[0024] Figs. 8A-8F are schematic view sequentially illustrating a method of repairing a defect site on a tissue surface using an instrument according to another embodiment.

Detailed Description

[0025] Fig. 1 shows one embodiment of an instrument 10 for determining the proper orientation for repairing a defect site 12 on a tissue surface 14. The tissue surface 14 may be a bone surface, a cartilage surface, a skin surface, a dental surface, or any other surface having a defect that requires treatment. For example, the defect site 12 may be located in the articular cartilage covering the condyles (not shown) at the distal end of the femur. In such situations, the instrument 10 is particularly advantageous for establishing an angle substantially perpendicular to the tissue surface 14, as will be described in greater detail below.

[0026] The instrument 10 includes a shaft 20 having a first end 22 configured to contact the tissue surface 14 and a second end 24 opposite the first end 22. In the illustrative embodiment shown, the shaft 20 is a cannula defined by an outer wall 26 surrounding a central bore 28. The first end 22, which may be beveled or flat, has a first diameter and the second end 24 has a second diameter larger than the first diameter. As a result, the second end 24 defines a flange portion 30. The flange portion 30 terminates in an upper surface 32 and the first end 22 terminates in a lower surface 34. Although the entire shaft 20 is shown as being transparent (for reasons discussed below), in other embodiments the shaft 20 may only be transparent in select areas or not transparent at all.

[0027] A plurality of probes 40 are operatively coupled to the shaft 20 and configured to extend beyond the first end 22. For example, the probes 40 may be partially received in a plurality of channels 42 extending into the outer wall 26 from the lower surface 34. The number of probes 40 and their spacing relative to each other may vary. Fig. 1 illustrates four of the probes 40 equally spaced about the periphery of the shaft 20. Because the shaft 20 is substantially cylindrical, each of the probes 40 are spaced approximately 90° apart from adjacent probes 40. In other embodiments, the instrument 10 may only include two probes 40 spaced approximately 180°

apart. Equally spacing an even number of probes 40 apart from each other has particular advantages that will be described in greater detail below. However, in alternative embodiments, an odd number of probes 40 may be spaced about the periphery of the shaft 20.

[0028] The probes 40 are movable relative to the shaft 20, and the displacement of each probe 40 relative to the first end 22 is communicated to at least one indicator 50. Fig. 1 shows a plurality of indicators 50 corresponding to the number of probes 40. However, those skilled in the art will appreciate that the displacements of the probes 40 may alternatively be communicated to a single indicator (not shown) or to a different number of indicators. Any type of indicator configured to communicate the displacements of the probes 40 to a practitioner utilizing the instrument 10 may be used.

[0029] For example, as shown in Fig. 2, the indicators 50 may each comprise a displacement scale 52 provided on the upper surface 32. Each displacement scale 52 is marked with indicia 54 corresponding to the distance of the distal end of one of the probes 40 (Fig. 1) relative to the first end 22. A marking element 56 moves along the indicia 54 when the associated probe 40 moves relative to the first end 22. The transparency of the shaft 20, and the upper surface 32 in particular, allows a practitioner to view the displacement information. The portions of the upper surface above the marking elements 56 may be the only transparent portions of the shaft 20 in some embodiments. Additionally, rather than providing visual indication of the displacements, the indicators 50 may alternatively be configured to provide tactile and/or audible feedback to communicate the displacements to a practitioner. The manner in which the displacements are transmitted to the indicators 50 may vary. Several representative examples are described below, with like reference numbers being used to refer to like structure throughout the various embodiments.

[0030] First, Fig. 3 is a cross-section of a portion of the shaft 20 illustrating a probe 58 and channel 60 in further detail. The probe 58 in this embodiment is operatively coupled to the indicator 50 (Fig. 3A) by fluid 62 (e.g., liquid and/or gas) within the channel 60 so that the displacement of the probe 58 is hydraulically and/or pneumatically communicated to the indicator 50. More specifically, the channel 60 extends upward from the first end 22 before curving outwardly toward the periphery of the shaft 20 within the flange portion 30. An upper portion 64 of the channel 60 may be visible through the upper surface 32.

[0031] The fluid 62 is maintained within the channel 60 by first and second plunger elements 66, 68 that seal, engage, and move within the channel 60. The first plunger element 66 is positioned proximate to the first end 22 and coupled to the probe 58. As a result, the probe 58 displaces the first plunger element 66 within the channel 60 when moving relative to the first end 22. The fluid 62 within the channel 60 communicates this displacement to the second plunger element 68, which is positioned in the upper portion 64 of the channel 60. As shown in Fig. 3A, the second plunger element 68 may be provided with a scribe 70 that can be seen from the upper surface 32 so as to serve as the marking element 56 (Fig. 2) of the indicator 50. The second plunger element 68 moves the scribe 70 along the displacement scale 52 in response to changes in fluid pressure and displacement created by the movement of the first plunger element 66 within the channel 60.

[0032] With reference to Fig. 4, the displacement of a probe 80 may instead be mechanically communicated to the indicator 50. Such an embodiment may still include a channel 82 extending from the first end 22 of the shaft 20 and curving into the flange portion 30. The channel 82 may also include an upper portion 84 visible through the upper surface 32. However, the probe 80 may comprise an elongated element occupying a substantial portion of the channel 82. The probe 80 has a tip portion 88 configured to contact the tissue surface 14 and an end portion 90 extending into the upper portion 84 of the channel 82.

[0033] The tip portion 88, end portion 90, and a middle portion 92 therebetween may comprise the same or different materials. In one embodiment, the tip portion 88 comprises a first material and the middle portion 92 and/or end portion 90 comprises a second material that is less rigid than the first material. For example, the first material may be steel or titanium and the second material may be nitinol. It will be appreciated that the first material is selected to provide the tip portion 88 with sufficient rigidity so as to be effectively displaced within the channel 82 upon contact with the tissue surface 14. The second material is selected to provide the middle portion 92 and/or end portion 90 with sufficient flexibility to translate through the channel 82 despite its curvature. Advantageously, the end portion 90 and middle portion 92 are captured within the channel 82 to prevent separation of the probe 80 from the shaft 20 and to prevent interference with the movement of the probe 80.

[0034] The end portion 90 of the probe 80 is configured to communicate the displacement of the tip portion 88 to the indicator 50. More specifically, the end portion 90 may include a plunger element 96 configured to slide within the upper portion 84 of the channel 82. Although Fig. 4A

illustrates the plunger element 96 including a scribe 98 that serves as the marking element 56 (Fig. 2), the scribe 98 may alternatively be provided on a contiguous segment of the probe 80 so as to eliminate the need for the plunger element 96. A spring 100 biases the end portion 90 within the channel 82 so that the tip portion 88 normally extends an initial distance beyond the first end 22. When the tip portion 88 is displaced into the channel 82, the probe 80 moves relative to the shaft 20 and causes the scribe 98 to move along the displacement scale 52.

[0035] Fig. 5 illustrates an alternative embodiment in which the displacement of a probe 110 relative to the first end 22 is amplified as it is mechanically communicated to the indicator 50. In the embodiment shown, the amplification is accomplished by providing a lever 112 within a shaft 114. The lever 112 is coupled to the shaft 114 at a pivotal connection 116 above a first channel 118, which extends upwardly from the lower surface 34 in a generally vertical direction. The probe 110 is a first elongated element configured to slide within the first channel 118. When the probe 110 contacts the lever 112, the lever 112 is rotated about the pivotal connection 116.

[0036] The shaft 114 further includes a second channel 122 that extends through a flange portion 124 in a generally horizontal direction. The second channel 122 may be visible through an upper surface 126, much like the upper portions 64 (Fig. 3) and 84 (Fig. 4), and the indicator 50 may once again be a displacement scale 52 provided on the upper surface 126. A second elongated element 130 is received in the second channel 122 and may be biased toward the first channel 118 by a spring 132. The second elongated element 130 contacts the lever 112 on an opposite side and spaced apart from the probe 110. Thus, when the probe 110 is displaced within the first channel 118 to rotate the lever 112, the lever 112 will displace the second elongated element 130 outwardly toward the periphery of the shaft 114. The displacement of the second elongated element 130 relative to that of the probe 110 will depend upon the mechanical advantage provided by the lever 112. This displacement may be viewed and analyzed by providing a scribe 136 (Fig. 5A) on the second elongated element 130 that moves along the displacement scale 52. As with the previous embodiment, the components associated with the probe 110 (e.g., the lever 112, the second elongated element 130) and portions of the probe 110 itself are captured within the shaft 114 to prevent separation from the shaft 114 and interference with their operation.

[0037] Fig. 6 illustrates an embodiment in which the displacements of probes 150 relative to a first end 152 of a shaft 156 are electrically communicated to indicators 154. In this embodiment, each probe 150 is received in a corresponding first channel 158 defined in a wall 160 of the shaft

156. Each first channel 158 extends upwardly from the first end 152 in a generally vertical direction. Again, the first end 152 may be beveled to facilitate displacement of the probes 150 within the first channels 158 when the shaft 156 is brought into contact with the tissue surface 14.

[0038] The probes 150 may be any type of sensor configured to generate a signal corresponding to displacement. For example, each probe 150 may comprise a linear variable differential transformer (LVDT) that converts linear motion into corresponding electrical signals. Alternatively, each probe 150 may include a strain gauge or similar sensor that varies a property associated with an electrical signal (e.g., resistance) in proportion to the deformation and/or load experienced by the probe 150. In still other embodiments, a series of magnets (not shown) may be associated with each probe 150. The magnets generate a series of pulses when the probes 150 are displaced, and these pulses are associated with the corresponding displacements by a linear encoder.

[0039] Wires 164 coupled to the probes 150 communicate the electrical signals to a signal processor 166, which is schematically shown in Fig. 6. There may be a single signal processor 166 for all of the probes 150 or a plurality of signal processors 166 corresponding to the number of probes 150. Additionally, the signal processor 166 may be located in any suitable location, including within the wall 160 of the shaft 156, on the exterior of the shaft 156, or at a location remote from the shaft 156. For example, the instrument 10 may further include a transmitter and receiver (not shown) for wirelessly sending signals to and receiving signals from the signal processor 166.

[0040] The signal processor 166 in Fig. 6 is coupled to the indicators 154 by wires 170. After processing the signals received from the probes 150, the signal processor 166 generates displacement signals to operate the indicators 154. As mentioned above, any type of indicator configured to communicate the displacements of the probes 150 to a practitioner utilizing the instrument 10 may be used. Thus, it will be appreciated that the indicators 154 need not be positioned on the shaft 156 such that wires 170 are not required. For example, in a manner not shown herein, the indicators 154 may be located on a video monitor (not shown) viewed by the practitioner. The instrument 10 in such an embodiment may further include a transmitter to send electrical signals from the probes 150 to a receiver and/or processor associated with the video monitor. To this end, the indicators 154 may be operatively coupled (i.e., linked) to the probes

150 through wireless communication signals. Such an arrangement provides the practitioner with a “heads up” display.

[0041] Referring back to Fig. 6, the indicators 154 in the embodiment shown each comprise a displacement scale 172 provided on the upper surface 32 and an electrically actuated marking element 174 moveable along the displacement scale 172. The displacement signals sent by the signal processor 166 control the displacement of the electrically actuated marking elements 174. Thus, the position of the electrically actuated marking elements 174 along the displacement scales 172 generally indicate the displacement of the probes 150 relative to the first end 152 of the shaft 156. Although the electrically actuated marking elements 174 are each shown as a plunger element that serves the same function as the plunger element 96 (Fig. 4), any element capable of moving along the displacement scale 172 in response to electrical signals may be used.

[0042] In other embodiments, a moveable marking element is not required to communicate the displacements of the probes 150 to a practitioner. For example, Fig. 7 shows a plurality of indicators 184 each comprising a row of light sources 186, such as LED's, provided on the upper surface 32 of the shaft 156. Each row of light sources 186 is aligned above one of the probes 150 (Fig. 6), and each light source 186 represents a particular displacement of the associated probe 150 relative to the first end 152. The light sources 186 are electrically coupled to the signal processor 166 by wires 188 and operated in response to the displacement signals generated by the signal processor 166. Thus, as the probes 150 are moved in and out of the channels 158, different ones of the light sources 186 are operated (i.e., lit up) to visually communicate the displacements to a practitioner.

[0043] Although several representative embodiments are described above, those skilled in the art will appreciate that the displacement of the probes 40 (Fig. 1) relative to the first end 22 of the shaft 20, and/or the distance of the first end 22 relative to a tissue surface, may be communicated to the indicators 50 using other technologies and techniques. For example, the instrument 10 may further include laser measurement sensors (not shown) that communicate information of the probes 40 and/or first end 22 to the indicators 50. In other embodiments, the displacement of each probe 40 may be sonically or pneumatically communicated to the indicators 50. To this end, the instrument 10 may include sonic transmitters and receivers (not shown) disposed about the shaft 20 for measuring the relative distance between the first end 22 and a tissue surface. A

combination of these arrangements may also be used in any particular embodiment. For example, the displacement of one probe 40 may be mechanically communicated to an indicator 50 while the displacement of another probe 40 may be electrically communicated to a different indicator 50. Alternatively, each probe 40 and channel 42 may be configured to operate as a hydraulic cylinder, and the instrument 10 may further include a pressure sensor (not shown) associated with the probe 40. Signals generated by the pressure sensor in response to displacement of the probe 40 are transmitted to the indicators 50 using a signal processor. Thus, in such an embodiment, each probe 40 incorporates aspects of the hydraulic and electrical communication discussed above with respect to the embodiments of Figs. 3, 6, and 7.

[0044] With reference to Figs. 8A-8F, a method of repairing a defect site 200 on a tissue surface 202 will now be described. The method involves using an instrument 204 similar to the instrument 10. However, to simplify matters, Figs. 8A-8F do not illustrate the probes 40 and indicators 50 (Fig. 2) in detail. These elements are instead shown schematically in Figs. 8A-8F because reference can be made to the description above for a more complete understanding of their operation. Indeed, those skilled in the art will appreciate that that the instrument 204 shown in Figs. 8A-8F may incorporate any of the features described above.

[0045] The method begins by first positioning the instrument 204 proximate the patient's body. If the tissue surface 202 is subcutaneous, an incision (not shown) is made in the patient's skin to gain access to the defect site 200. The incision may be relatively small if the method is performed arthroscopically, or larger if the method is performed using mini-arthrotomy or open surgical techniques. An obturator (not shown) may be placed within the central bore 28 (Fig. 8C) to facilitate inserting the instrument 204 through the patient's skin regardless of which surgical technique is used. Prior to contact with the tissue surface 202, the probes 40 extend an initial distance beyond the first end 206 of the shaft 20. For example, the probes 40 may extend approximately 4 mm beyond the first end 206. Those skilled in the art will appreciate that this initial distance may vary among the probes 40, and may be set depending on the expected profile/geometry of the tissue surface 202. As shown in Fig. 8A, the instrument 204 is then moved toward the defect site 200, which may be a cavity or other irregularity on the tissue surface 202. The instrument 204 may be moved toward the defect site 200 at any angle because a desired orientation can later be established.

[0046] Fig. 8A illustrates the shaft 20 being substantially aligned along an axis 210 when the first end 206 is brought into contact with the tissue surface 202. The desired orientation for preparing the defect site 200 may be along a desired axis 212, which may be substantially perpendicular to a plane 214 tangent to the tissue surface 202 at the defect site 200, especially when the tissue surface 202 has a relatively large degree of curvature. Thus, the angle of the shaft 20 relative to the tissue surface 202 is then analyzed to determine if a change in orientation is required. This determination is made based upon displacement information communicated by the indicators 50.

[0047] More specifically, when the first end 206 of the shaft 20 contacts the tissue surface 202, one or more of the probes 40 will also contact the tissue surface 202 and be displaced into the associated channel 42 (Fig. 8C). Arthroscopic or visual examination of the probes 40 may be performed after the instrument 204 is inserted into the patient's body to confirm that the probes 40 have unobstructed access to the tissue surface 202 surrounding the defect site 200. Unless the axis 210 is substantially aligned along the desired axis 212 after the shaft 20 contacts the tissue surface 202, the probes 40 will have different displacements relative to the first end 206. This displacement information is transmitted to the indicators 50 using any of the techniques described above. The indicators 50, in turn, communicate the displacement information to the practitioner. For example, the indicators 50 may display the displacement information using the displacement scales 52 (Fig. 2) or light sources 186 (Fig. 6).

[0048] As shown in Figs. 8A and 8B, the practitioner may adjust the angle of the shaft 20 relative to the tissue surface 202. Moving the shaft 20 in such a manner will change the displacements of the probes 40 relative to the first end 206. When the axis 210 is substantially aligned with the desired axis 212, the displacements of the probes 40 may be approximately equal. This is because on articular cartilage or the like, the surface profile of the tissue surface 202 may approximate that of a sphere in the localized area around the defect site 200. However, to approximate alignment with the desired axis 212 even more accurately, each of the probes 40 may be spaced approximately 180° apart from another one of the probes 40. Such an arrangement enables the practitioner to compare the displacements between opposite probes 40 in the same plane to determine whether the angle of the shaft 20 relative to the tissue surface 202 should be adjusted in that particular plane.

[0049] Increasing the number of probes 40 spaced about the shaft 20 enables the practitioner to take into account a greater number of planes when making adjustments. In general, the greater number of planes (and, hence, probes 40) in which displacement is compared, the more effectively the surface profile of the tissue surface 202 is taken into account. Additionally, increasing the number of probes 40 produces a more reliable (i.e., repeatable) indication of perpendicularity. For example, when the surface profile of the tissue surface 202 is more effectively taken into account, the shaft 20 is more likely to have the same orientation when moved to the desired axis 212 (using the procedure described above) regardless of any rotation about the desired axis 212. When only discreet or localized information about the tissue surface 202 is provided, reliable/repeatable indications are more difficult to obtain.

[0050] After making adjustments to properly orient the instrument 204, the practitioner maintains the shaft 20 at substantially the desired angle relative to the tissue surface 202. This may be accomplished manually by hand while monitoring the indicators 50 as necessary. An external support or fixation system (not shown) may also be provided to secure the instrument in the desired position once it is determined (e.g., similar to stereotactic procedures). As shown in Figs. 8C and 8D, a defect preparation tool 230 may then be inserted through the central bore 28 and toward the defect site 200. Although the defect preparation tool 230 is shown as a drill, any other device configured to prepare a defect to receive an implant 240 (Fig. 8E) may be used. Other examples of suitable defect preparation tools include, without limitation: punches, curettes, reamers, and picks.

[0051] The defect preparation tool 230 is configured to prepare the defect site 200 to a desired size, shape, and/or depth for receiving the implant 240. For example, the defect preparation tool 230 may form a cavity 232 having a size and shape generally corresponding to the implant 240. After preparing the defect site 200, the defect preparation tool 230 may be removed from the central bore 28. The central bore 28 may then serve as a conduit for the removal of any debris. Additionally, as shown in Fig. 8E, the implant 240 may be inserted into the central bore 28 and delivered to the defect site 200 through the shaft 20. The implant 240 is pushed through the shaft 20 using a driving tool 244.

[0052] Again, throughout the procedure, the shaft 20 may be maintained at a desired angle relative to the tissue surface 202 by monitoring the displacement information displayed by the indicators 50. The implant 240 is advantageously delivered along the same axis along which the

defect preparation tool 230 was aligned when forming the cavity 232. Such a procedure facilitates delivering the implant 240 so that the implant 240 may be fully seated within the cavity 232.

[0053] As shown in Fig. 8F, the driving tool 244 and instrument 204 are eventually moved away from the tissue surface 202 when the procedure is complete. Because the cavity 232 was prepared at an angle substantially perpendicular to a tangent of the tissue surface 202 at the defect site 200, a top surface 242 of the implant 240 may be substantially flush with the tissue surface 202 when fully seated within the cavity 232. Such an arrangement facilitates integration of the implant 240 to effectively treat the defect site 202. In particular, the implant 240 effectively occupies the defect site 200 so that there remains no substantial cavities or depressions relative to the surrounding tissue surface 202. Additionally, the absence of implant portions abruptly extending above the tissue surface 202 reduces or eliminates the risk of displacement or premature wear on the implant 240.

[0054] As a variation of the method described above, the instrument 204 or an additional harvesting instrument (not shown) that operates upon the same principles may be used to locate a similarly-shaped tissue surface after "mapping" the curvature of the tissue surface 202 and preparing the defect site 200. For example, after the instrument 204 is aligned with the desired axis 212, the displacement information is recorded, stored, committed to memory, or otherwise retained by the practitioner. The practitioner then attempts to match this displacement information when using the instrument 204 or harvesting instrument to select a remote tissue surface from which to harvest the implant 240. The remote tissue surface may be on the patient or a donor. Once a similarly-shaped remote tissue surface is located, the instrument 204 or harvesting instrument is used to cut or extract the implant 240 from the remote tissue surface. To this end, the instrument 204 or harvesting instrument may include a blade associated with its shaft 20. Alternatively, a separate cutting device or similar tool for extracting the implant 240 from the remote tissue surface may be inserted through the central bore 28.

[0055] The implant 240 is eventually delivered to the cavity 232 at the defect site 200 in the manner described above. Because the implant 240 was harvested from a remote tissue surface having the same or similar profile as the tissue surface 202, the top surface 242 of the implant 240 is more likely to approximate the natural curvature of the tissue surface 202.

[0056] While several embodiments are described above in considerable detail, the inventors do not intend to restrict or in any way limit the scope of the appended claims to such detail. Additional advantages and modifications will readily appear to those skilled in the art. For example, although the probes 40 described above move within the channels 42 formed in the shaft 20, the probes 40 may alternatively be located within tubes (not shown) provided on the exterior or interior of the shaft 20. Furthermore, those skilled in the art will appreciate that two or more of the components discussed above may be provided as part of assembly. For example, the assembly may include both the instrument 10 and the defect preparation tool 230. Alternatively or additionally, the assembly may include both the instrument 10 and the implant 240. The defect preparation tool 230 and/or implant 240 may be designed to effectively cooperate with the central bore 28 of the shaft 20 when provided as part of an assembly.

[0057] The invention in its broader aspects is thus not limited to the specific details, representative apparatus and methods, and illustrative examples shown and described. Accordingly, departures may be made from such details without departing from the scope or spirit of the general inventive concept.

[0058] What is claimed is:

1. An instrument for determining the proper orientation for repairing a defect site on a tissue surface, comprising:

a shaft having a first end configured to contact the tissue surface and a second end opposite the first end;

a plurality of probes operatively coupled to the shaft, each probe being movable relative to the shaft and configured to extend beyond the first end; and

at least one indicator operatively coupled to the plurality of probes, the at least one indicator being configured to display the displacements of the probes relative to the first end so that the displacements of the probes may be compared.

2. The instrument of claim 1 wherein the probes are substantially equally spaced about a periphery of the shaft.

3. The instrument of claim 1 wherein at least a portion of the shaft is substantially cylindrical and each probe is spaced approximately 180 degrees apart from another one of the probes.

4. The instrument of claim 3, wherein the plurality of probes includes first, second, third, and fourth probes spaced at 90 degree angles about the periphery of the shaft, and wherein the at least one indicator comprises first, second, third, and fourth indicators operatively coupled to first, second, third, and fourth probes, respectively.

5. The instrument of claim 1 wherein the at least one indicator comprises a plurality of indicators each configured to display to the displacement of a corresponding one of the probes.

6. The instrument of claim 5 wherein the shaft is a cannula defined by an outer wall surrounding a central bore, the shaft further including a plurality of channels defined in the outer wall for receiving the plurality of probes.

7. The instrument of claim 6 wherein the first end of the shaft has a first outer diameter and the second end has a second outer diameter greater than the first outer diameter so as to define a flange portion at the second end, the flange portion terminating in an upper surface, the plurality of channels each extending into the flange portion and including an upper portion visible through the upper surface, and each indicator comprising a displacement scale provided on the upper surface proximate the upper portion of one of the channels.

8. The instrument of claim 6 wherein the outer wall is beveled at the first end.
9. The instrument of claim 1 wherein the tissue surface comprises at least one of the following: a bone surface, a cartilage surface, a skin surface, or a dental surface.
10. The instrument of claim 1, further comprising:
a plurality of fluid channels operatively coupling the plurality of probes to the at least one indicator;
wherein the displacements of the probes are hydraulically communicated to the at least one indicator by the fluid channels.
11. The instrument of claim 10 wherein each probe comprises a plunger element that seals, engages, and moves within one of the fluid channels.
12. The instrument of claim 10 wherein the at least one indicator comprises a plurality of indicators each configured to display the displacement of one of the probes.
13. The instrument of claim 1 wherein the displacement of each probe relative to the first end is mechanically communicated to the at least one indicator.
14. The instrument of claim 13, the shaft including a plurality of channels corresponding to the plurality of probes, each channel including an upper portion visible through an outer surface of the shaft, the at least one indicator comprising a plurality of indicators each including a displacement scale provided on the shaft proximate to one of the upper portions, and the probes each comprising an elongated element received in the corresponding channel and having a tip portion configured to contact the tissue surface and an end portion opposite the tip portion, wherein the end portion communicates the displacement of the tip portion to the corresponding displacement scale.
15. The instrument of claim 14 wherein the end portion of each elongated element includes a scribe configured to move along the corresponding displacement scale when the associated tip portion moves relative to the shaft.
16. The instrument of claim 14 wherein at least a first portion of each elongated element comprises a first material and at least a second portion of each elongated element comprises a second material, the second material being less rigid than the first material.
17. The instrument of claim 13, further comprising:
a plurality of levers configured to communicate the displacements of the plurality of probes to the at least one indicator, each lever further configured to amplify the displacements

communicated to the at least one indicator.

18. The instrument of claim 1 wherein the displacement of each probe relative to the first end is electrically communicated to the at least one indicator.

19. The instrument of claim 18 wherein the at least one indicator is located remote from the shaft and operatively coupled to the plurality of probes by wireless communication signals.

20. The instrument of claim 18 wherein each probe comprises a linear variable differential transformer.

21. The instrument of claim 20 wherein the at least one indicator comprises a plurality of indicators corresponding to the plurality of probes, each indicator including a displacement scale provided on the shaft and an electrically actuated marking element movable along the displacement scale, the instrument further comprising:

a signal processor electrically coupled to the plurality of probes and the plurality of indicators, the signal processor configured to operate the plurality of indicators in response to signals received from the plurality of probes.

22. The instrument of claim 20 wherein the at least one indicator comprises a plurality of indicators corresponding to the plurality of probes and each including at least one light source, the instrument further comprising:

a signal processor electrically coupled to the plurality of probes and the plurality of indicators, the signal processor configured to operate the light sources in response to signals received from the plurality of probes.

23. The instrument of claim 1, further comprising:

a laser measurement sensor that communicates the displacement of each probe relative to the first end of the shaft when the first end is in contact with the tissue surface.

24. The instrument of claim 1 wherein the displacement of each probe relative to the first end is sonically communicated to the at least one indicator.

25. The instrument of claim 1 wherein the displacement of each probe relative to the first end is pneumatically communicated to the at least one indicator.

26. An instrument for repairing a defect site on a tissue surface, comprising:

a shaft having a first end configured to contact the tissue surface and a second end opposite the first end;

a plurality of probes associated with the shaft and each extending an initial distance

beyond the first end, each probe being configured to move relative to the shaft so as to be displaced when the first end contacts the tissue surface; and

a plurality of indicators corresponding to the plurality of probes, each indicator being configured to display information related to the displacement of a corresponding one of the probes when the first end of the shaft contacts the tissue surface.

27. The instrument of claim 26 wherein at least a portion of the shaft is substantially cylindrical and each probe is spaced approximately 180 degrees apart from another one of the probes.

28. An assembly for repairing a defect site on a tissue surface, comprising:
a positioning instrument, comprising:

a shaft having a first end configured to contact the surface of the tissue and a second end opposite the first end, wherein the shaft is a cannula defined by an outer wall surrounding a central bore;

a plurality of probes operatively coupled to the shaft, each probe being movable relative to the shaft and configured to extend beyond the first end; and

at least one indicator operatively coupled to the plurality of probes, the at least one indicator being configured to display the displacements of the probes relative to the first end so that the displacements of the probes may be compared; and

a defect preparation tool configured for displacement in the central bore of the shaft and configured to prepare the defect site for receiving an implant.

29. The assembly of claim 28 wherein the defect preparation tool is configured to extend through the central bore of the shaft.

30. The assembly of claim 28 wherein the defect preparation tool comprises at least one of the following: a drill, a punch, a curette, a reamer, or a pick.

31. The assembly of claim 28 wherein the shaft is transparent to allow visualization of the defect site and implant.

32. The assembly of claim 28 wherein the at least one indicator comprises a plurality of indicators each configured to display to the displacement of a corresponding one of the probes.

33. The assembly of claim 28 wherein the shaft further includes a plurality of channels defined in the outer wall for receiving the plurality of probes.

34. The assembly of claim 28 wherein the probes are substantially equally spaced about a

periphery of the shaft.

35. The assembly of claim 28, further comprising:

an implant configured to be received within the central bore of the shaft and delivered to the defect site through the central bore.

36. An assembly for repairing a defect site on a tissue surface, comprising:

a positioning instrument, comprising:

a shaft having a first end configured to contact the surface of the tissue and a second end opposite the first end, wherein the shaft is a cannula defined by an outer wall surrounding a central bore;

a plurality of probes operatively coupled to the shaft, each probe being movable relative to the shaft and configured to extend beyond the first end; and

at least one indicator operatively coupled to the plurality of probes, the at least one indicator being configured to display the displacements of the probes relative to the first end so that the displacements of the probes may be compared; and

an implant configured to be received within the central bore of the shaft and delivered to the defect site through the central bore.

37. The assembly of claim 36 wherein the shaft further includes a plurality of channels defined in the outer wall for receiving the plurality of probes.

38. A method of repairing a defect site on a tissue surface, comprising:

positioning a positioning instrument proximate to a patient's body, the positioning instrument having a shaft with a first end, a plurality of probes operatively coupled to the shaft and configured to extend beyond the first end, and at least one indicator operatively coupled to the plurality of probes;

contacting the tissue surface with the first end of the shaft and the plurality of probes, the displacement of each probe relative to the first end being transmitted to the at least one indicator;

determining the angle of the shaft relative to the tissue surface based on displacement information communicated by the at least one indicator.

39. The method of claim 38 wherein the tissue surface comprises at least one of the following: a bone surface, a cartilage surface, a skin surface, or a dental surface.

40. The method of claim 38, further comprising:

adjusting the angle of the shaft relative to the tissue surface.

41. The method of claim 40 wherein the at least one indicator audibly communicates the displacement information, and wherein adjusting the angle of the shaft relative to the tissue surface further comprises:

monitoring audio communications from the at least one indicator.

42. The method of claim 40 wherein the at least one indicator is configured to provide tactile feedback to communicate the displacement information, and wherein adjusting the angle of the shaft relative to the tissue surface further comprises:

sensing tactile feedback from the at least one indicator.

43. The method of claim 40 wherein the at least one indicator comprising a plurality of indicators, and wherein the displacement of each probe is transmitted to a corresponding one of the indicators.

44. The method of claim 43 wherein the plurality of indicators display the displacement information, and wherein determining the angle of the shaft relative to the tissue surface further comprises:

viewing the displacement information displayed by the plurality of indicators.

45. The method of claim 44 wherein adjusting the angle of the shaft relative to the tissue surface further comprises:

comparing the displacement information of at least two of the probes;

adjusting the angle of the positioning instrument relative to the tissue surface until the displacements of the at least two probes are substantially equal.

46. The method of claim 44 wherein viewing the displacement information displayed by the plurality of indicators comprises:

viewing a plurality of displacement scales associated with the plurality of indicators.

47. The method of claim 44 wherein viewing the displacement information displayed by the plurality of indicators further comprises:

viewing one or more light sources associated with each indicator, the light sources being operated by a signal processor in response to signals received from the plurality of probes.

48. The method of claim 38, the shaft being a cannula defined by an outer wall surrounding a central bore, the method further comprising:

substantially maintaining the shaft at a desired angle relative to the tissue surface;

inserting a defect preparation tool through the central bore; and

preparing the defect site to receive an implant.

49. The method of claim 48 wherein the defect preparation tool is a drill, and wherein preparing the defect site comprises:

drilling into the tissue surface to form a cavity.

50. The method of claim 48 wherein the defect preparation tool is a punch, and wherein preparing the defect site comprises:

punching into the tissue surface to form a cavity.

51. The method of claim 50, further comprising:

drilling into the tissue surface to further form the cavity into a desired shape.

52. The method of claim 48, further comprising:

removing the defect preparation tool from the central bore of the shaft; inserting an implant through the central bore; and

delivering the implant to the defect site through the shaft while maintaining the shaft at the desired angle relative to the tissue surface.

53. The method of claim 48 wherein substantially maintaining the shaft at a desired angle relative to the tissue surface comprises:

maintaining the shaft substantially perpendicular to the tissue surface at the defect site.

54. The method of claim 38 wherein the displacement of each probe is mechanically transmitted to the at least one indicator.

55. The method of claim 38 wherein the displacement of each probe is hydraulically transmitted to the at least one indicator.

56. The method of claim 38 wherein the displacement of each probe is electrically transmitted to the at least one indicator.

57. The method of claim 38 wherein the displacement of each probe is communicated to the at least one indicator by a laser measurement sensor.

58. The method of claim 38 wherein the displacement of each probe is sonically transmitted to the at least one indicator.

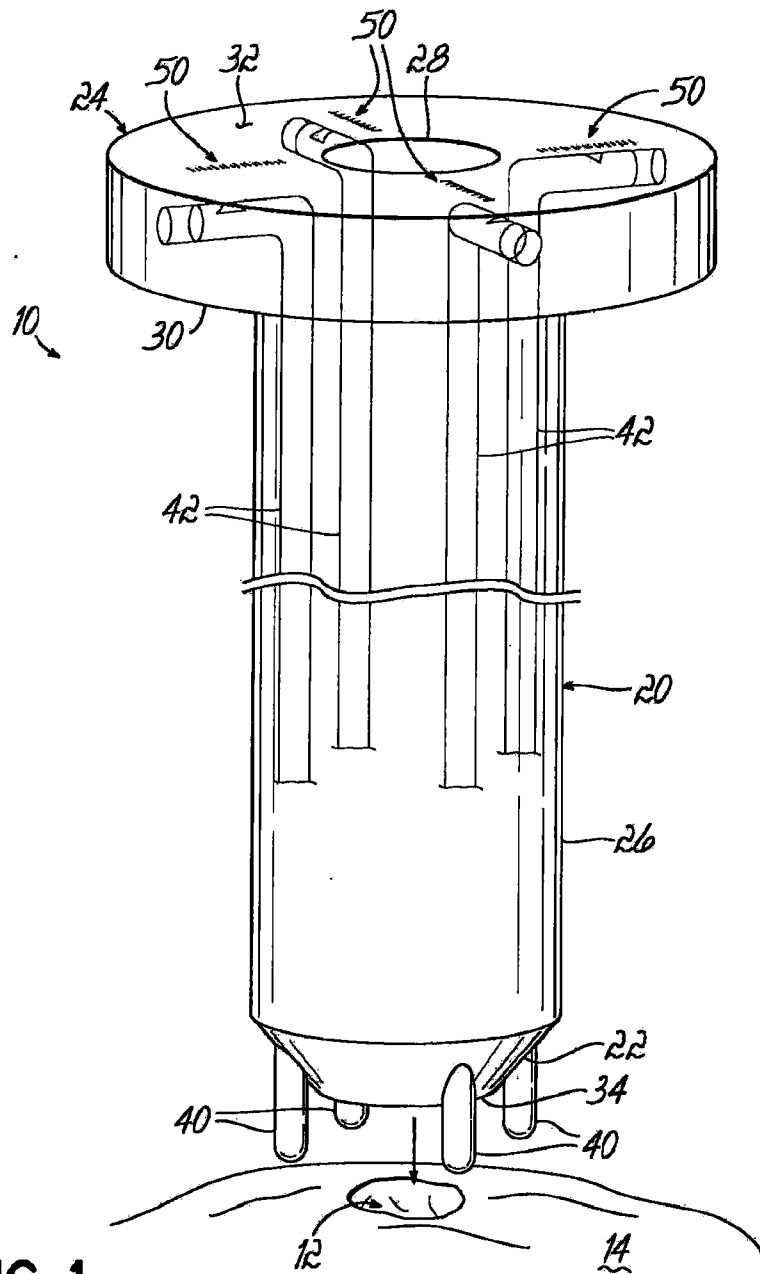

FIG. 1

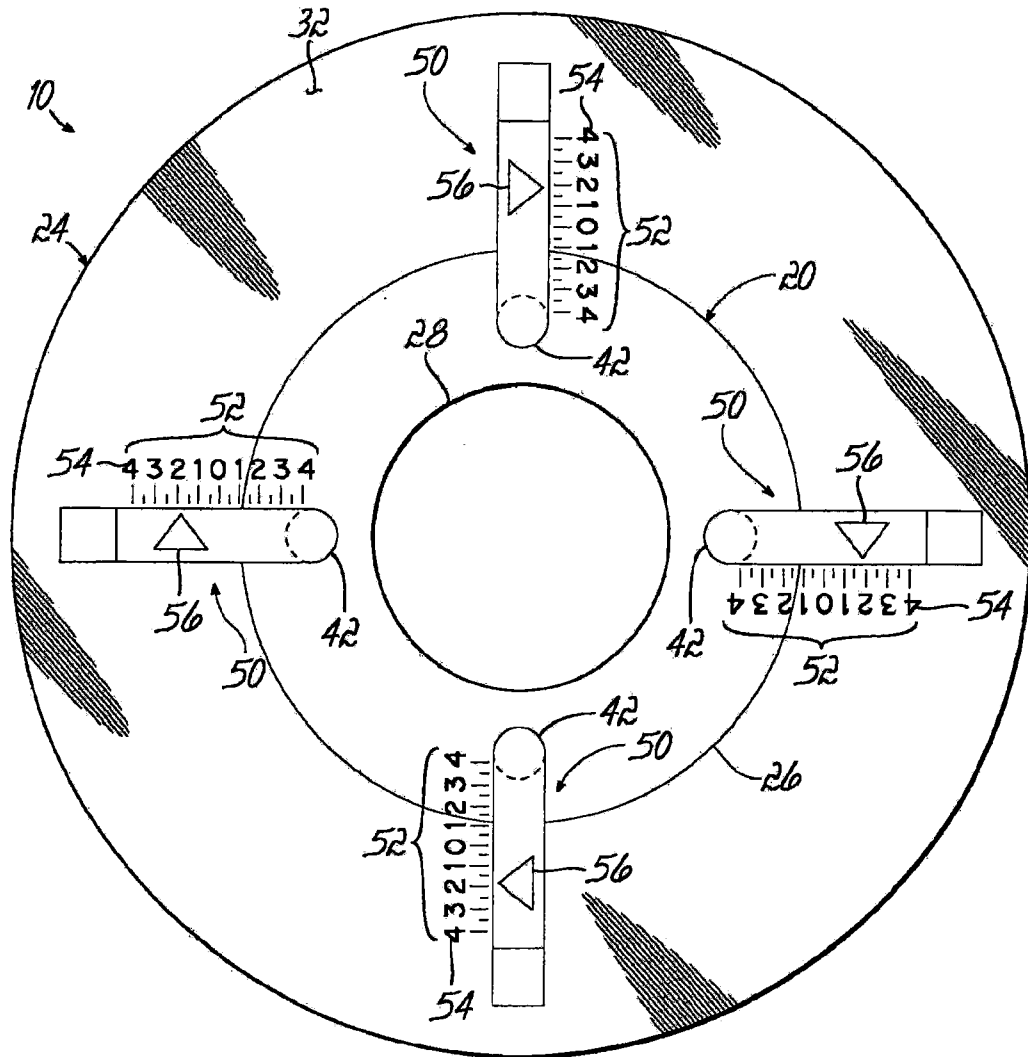

FIG. 2

3/10

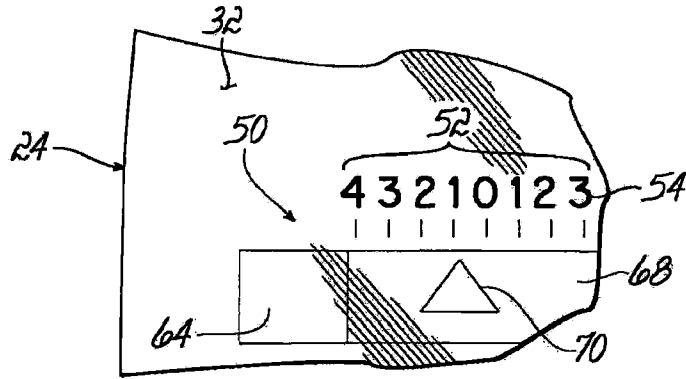

FIG. 3A

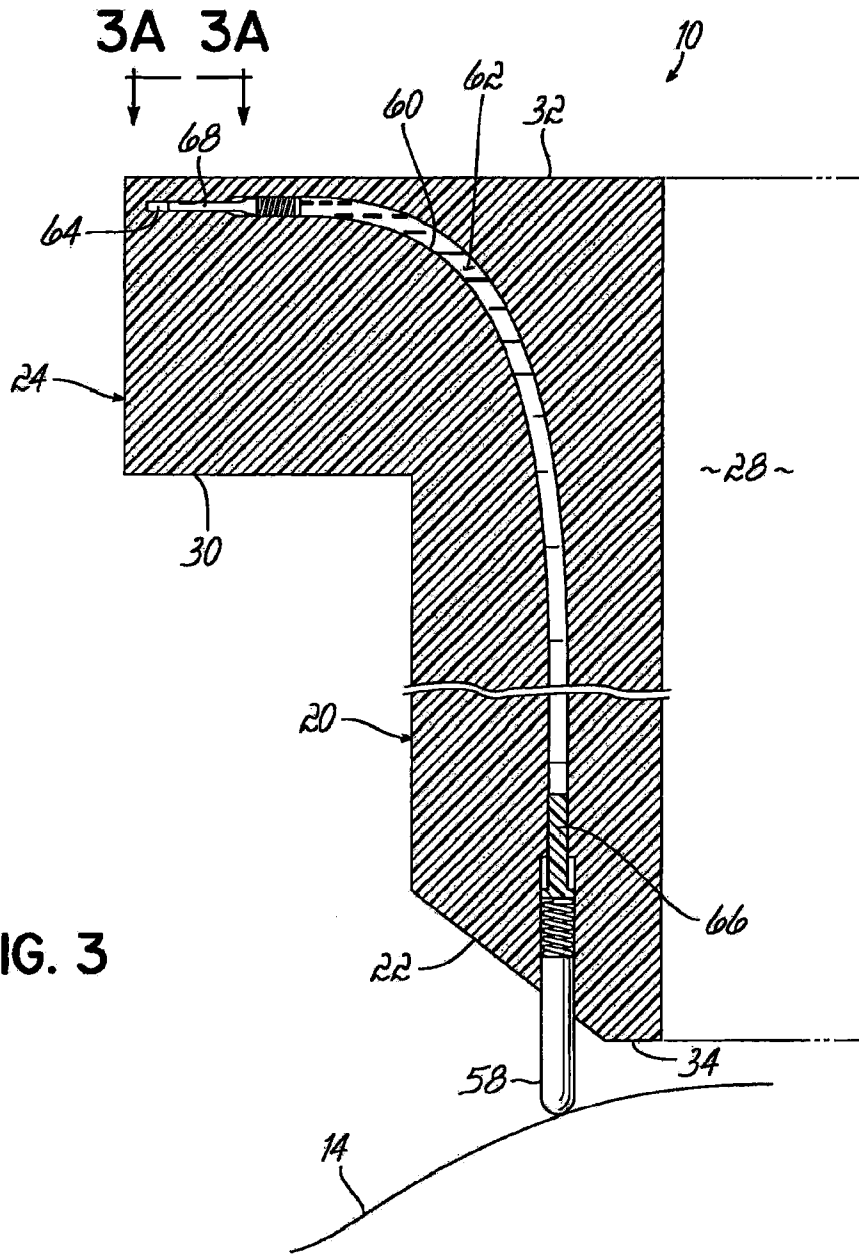

FIG. 3

4/10

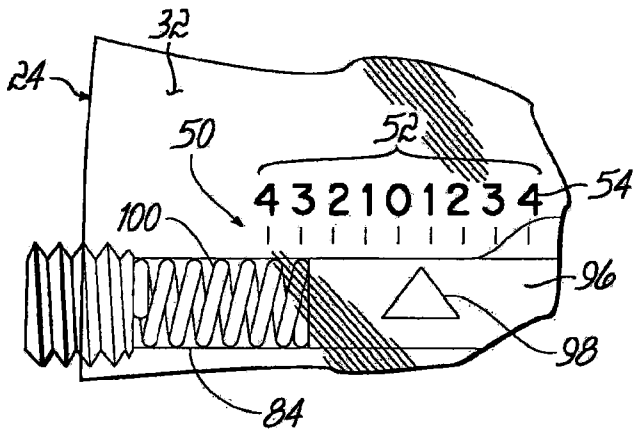

FIG. 4A

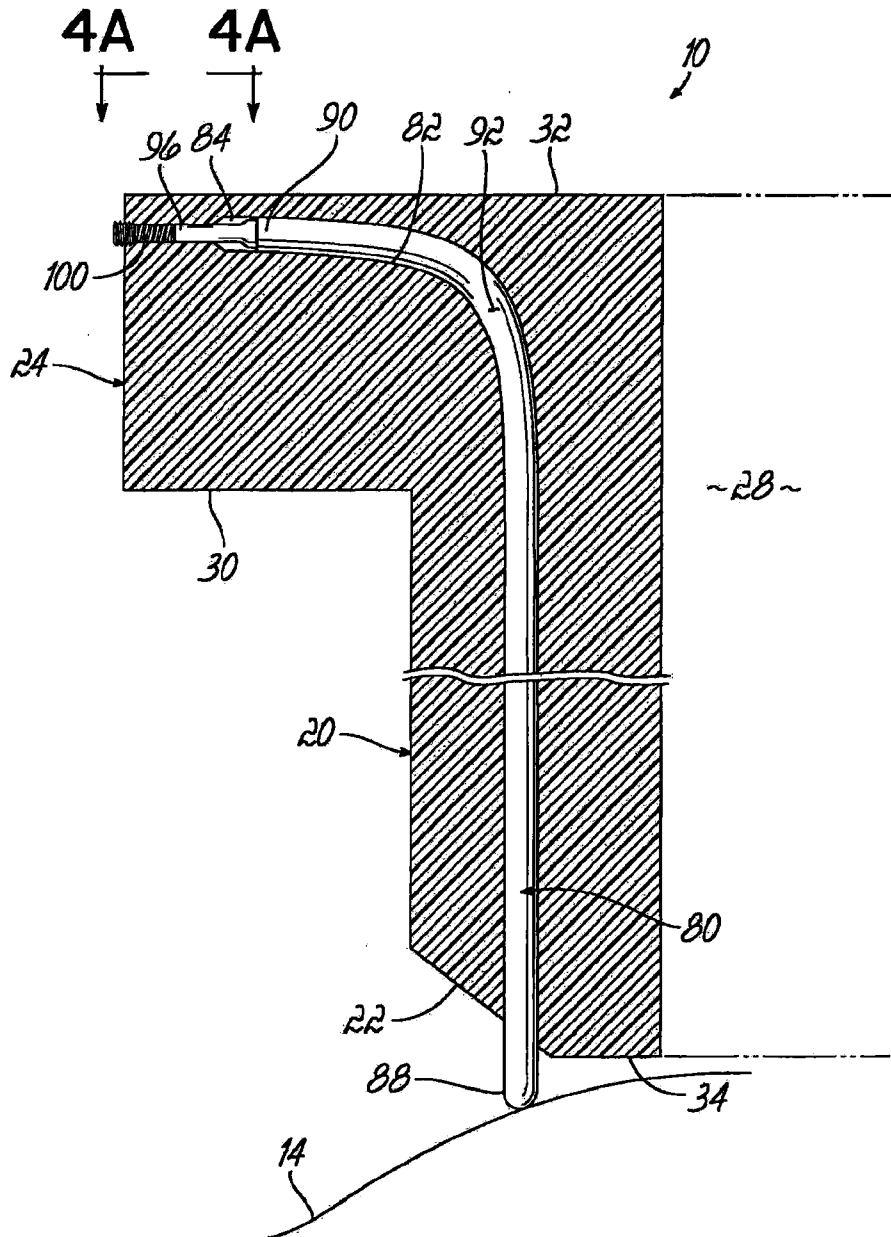

FIG. 4

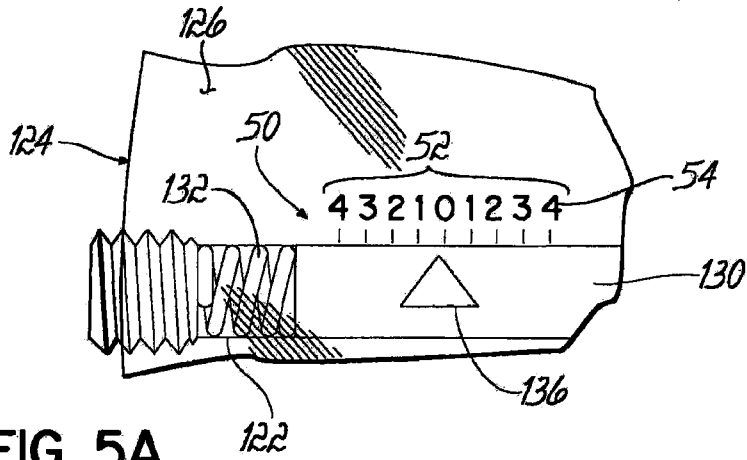

FIG. 5A

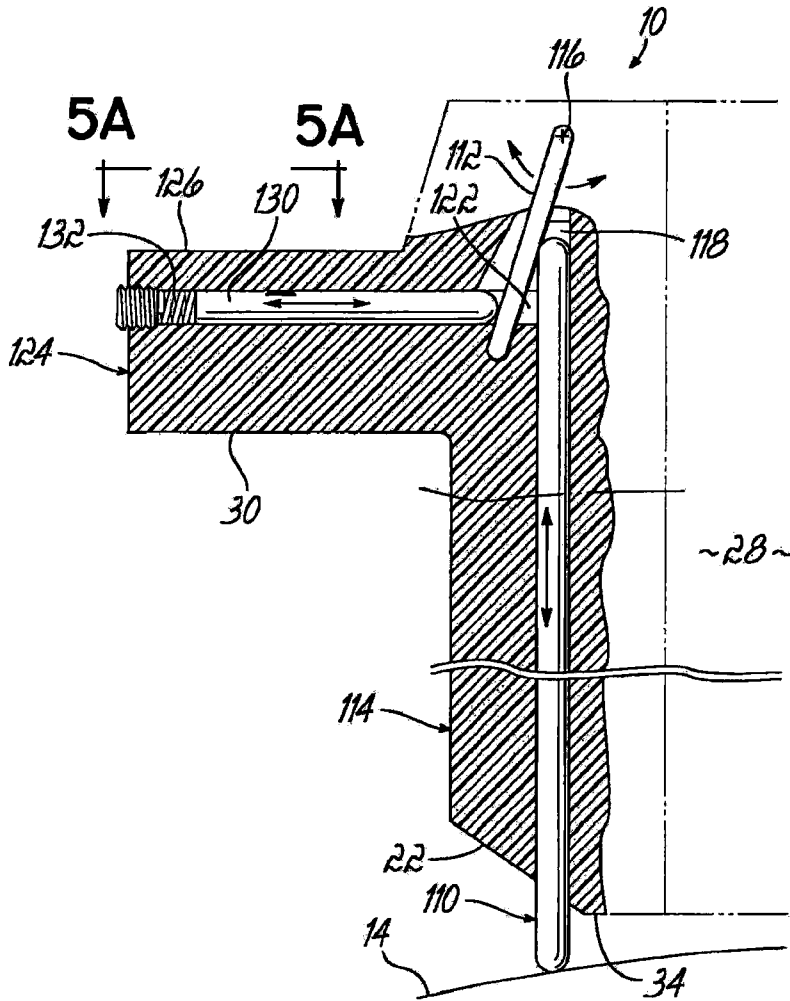

FIG. 5

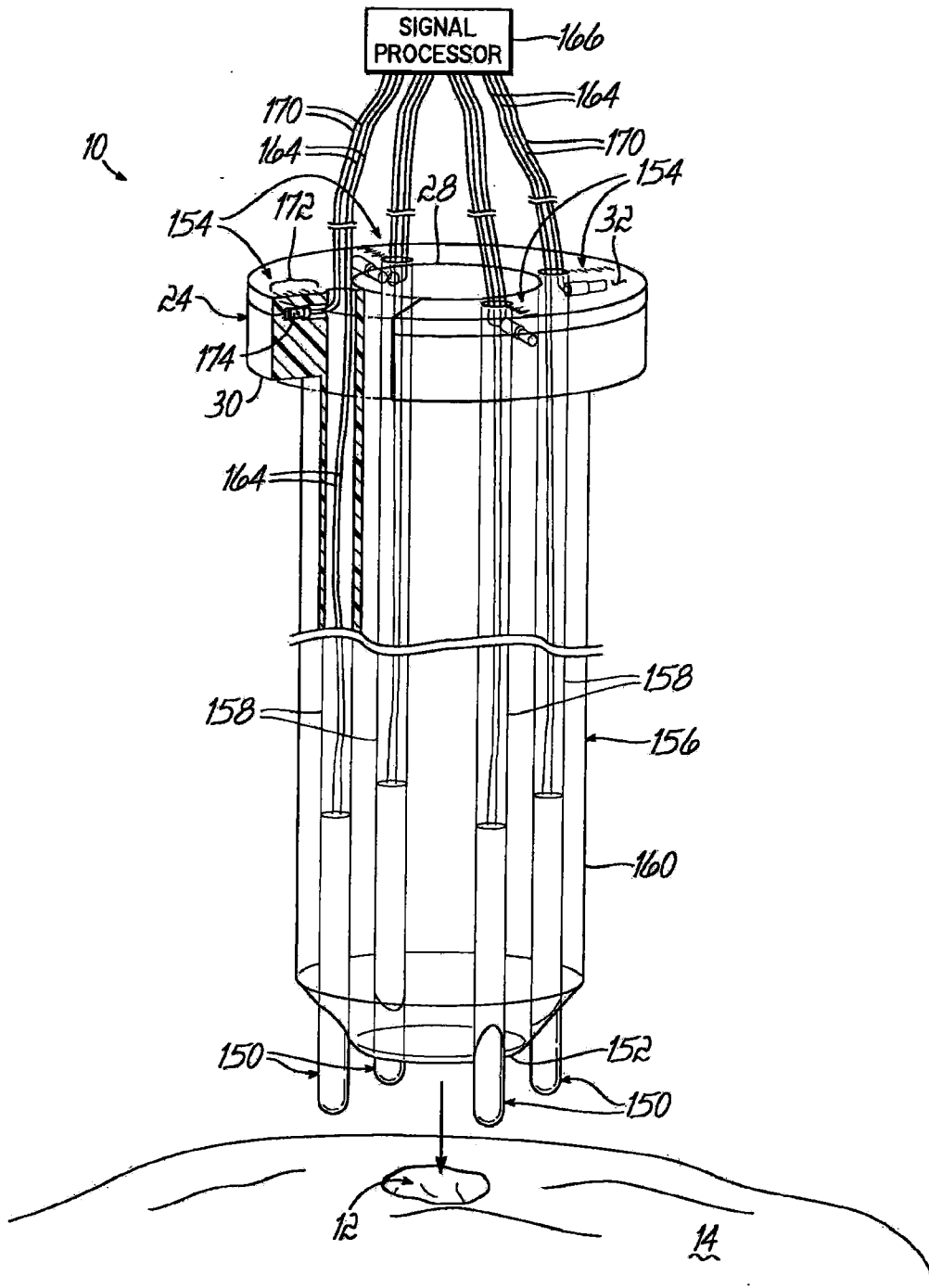

FIG. 6

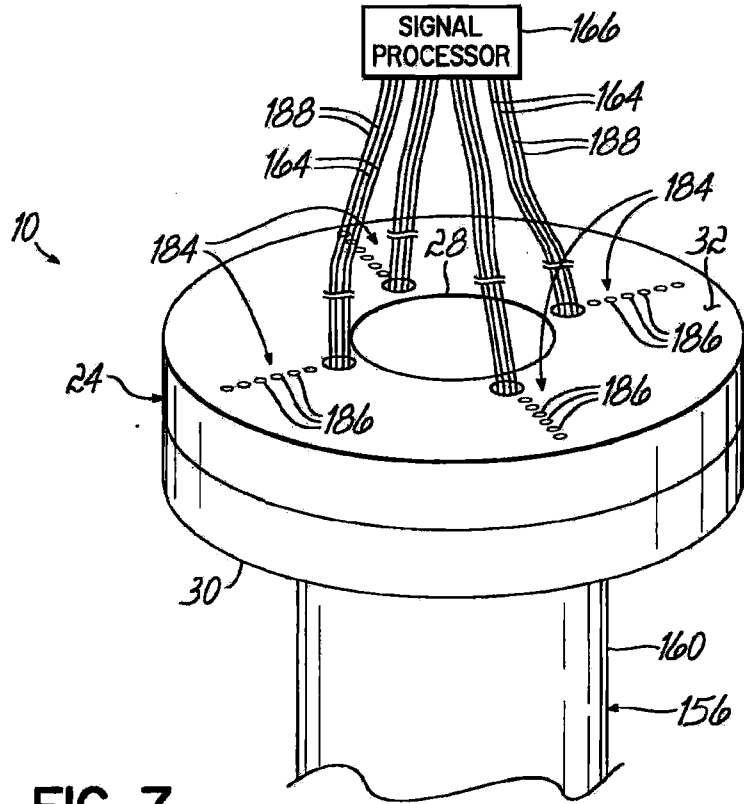

FIG. 7

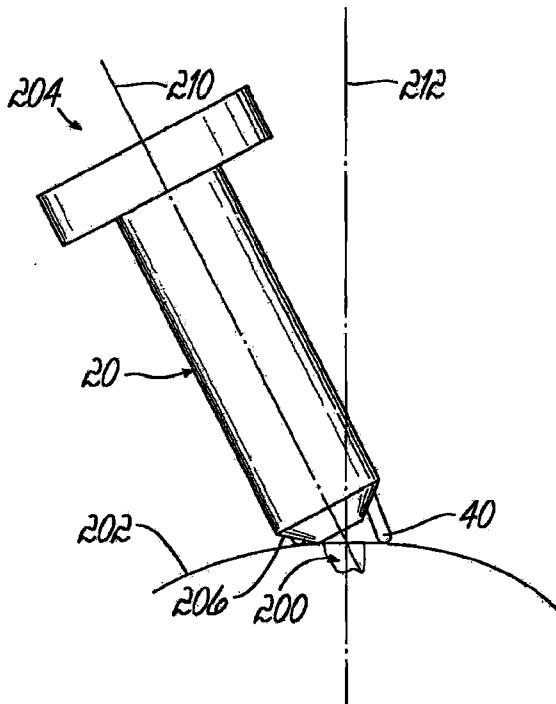

FIG. 8A

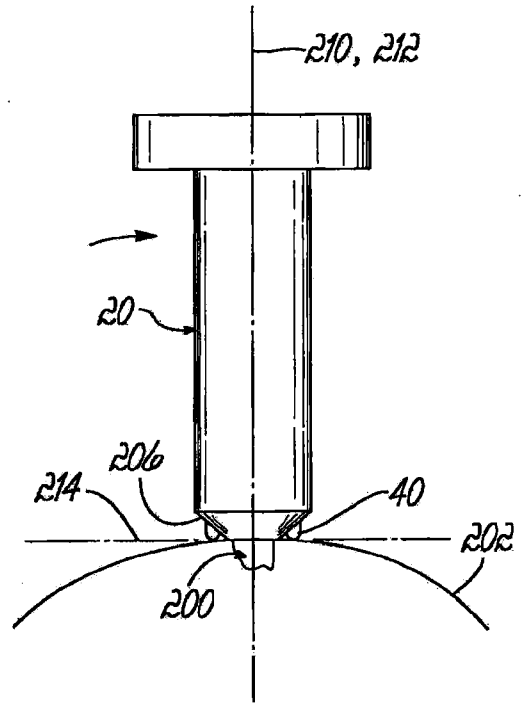

FIG. 8B

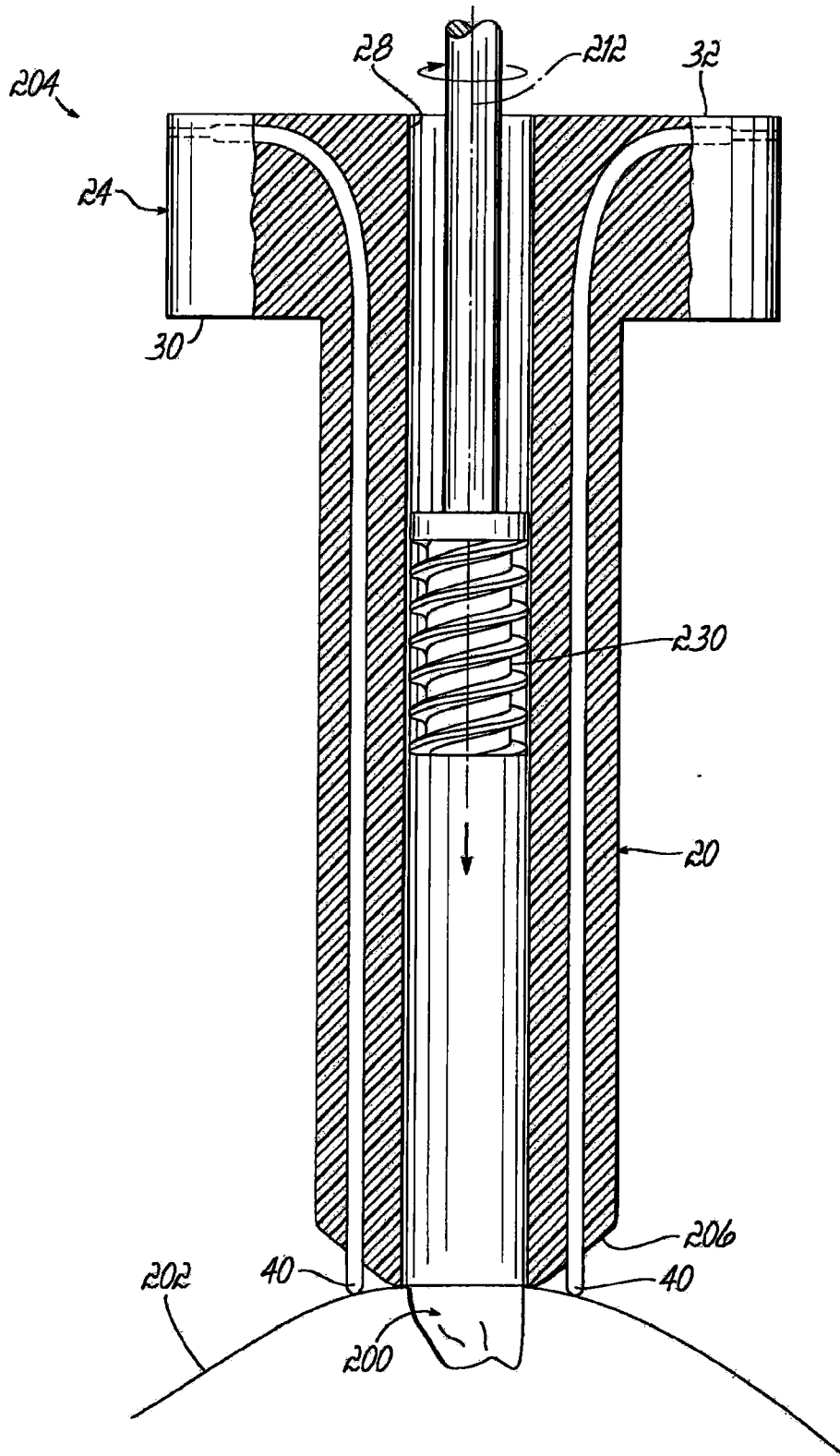

FIG. 8C

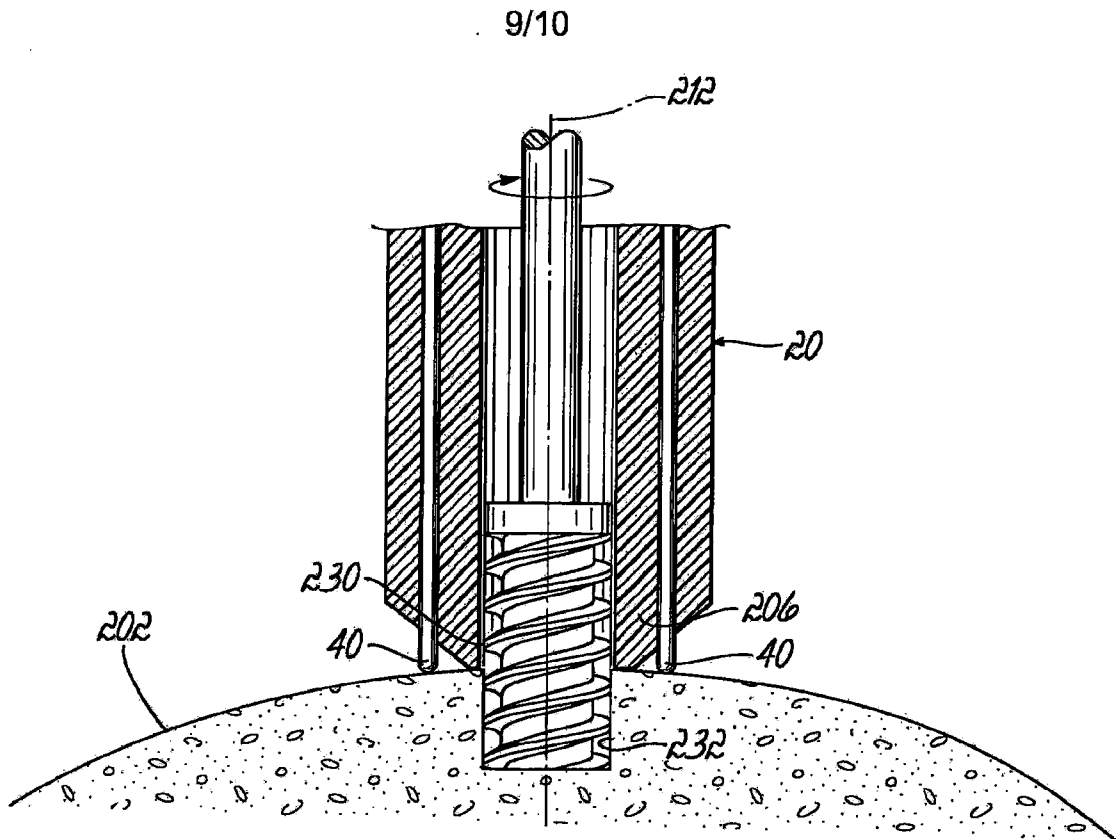

FIG. 8D

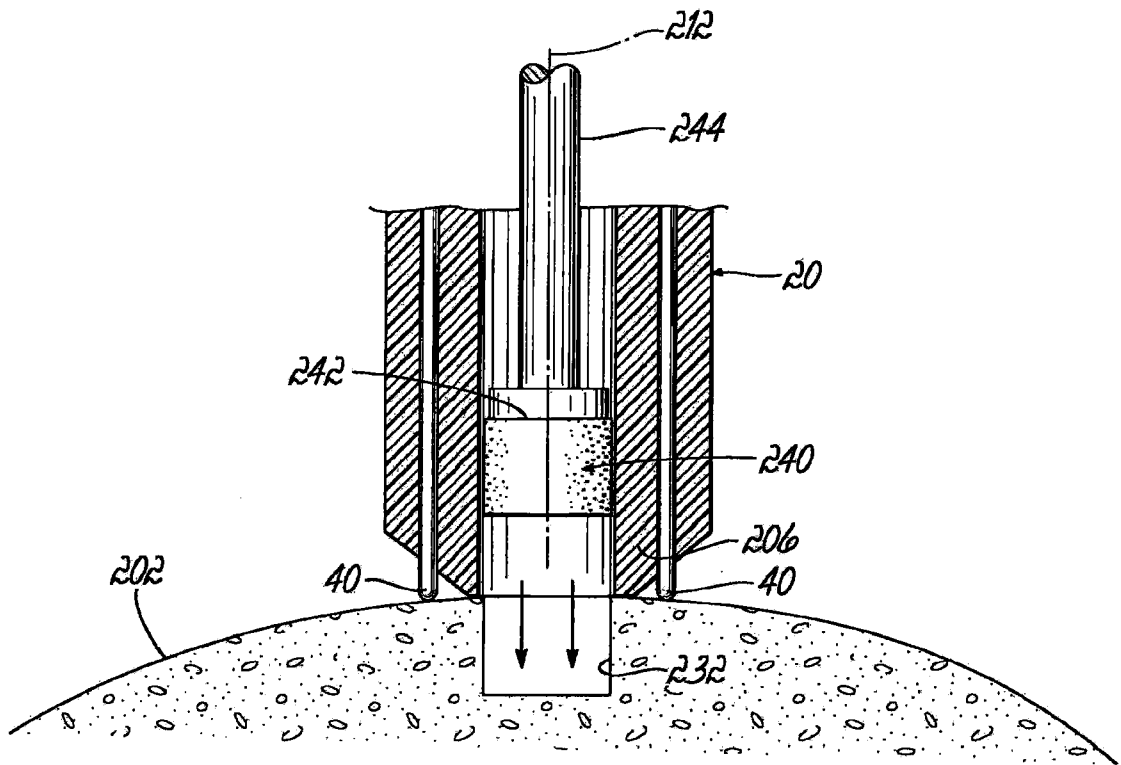

FIG. 8E

10/10

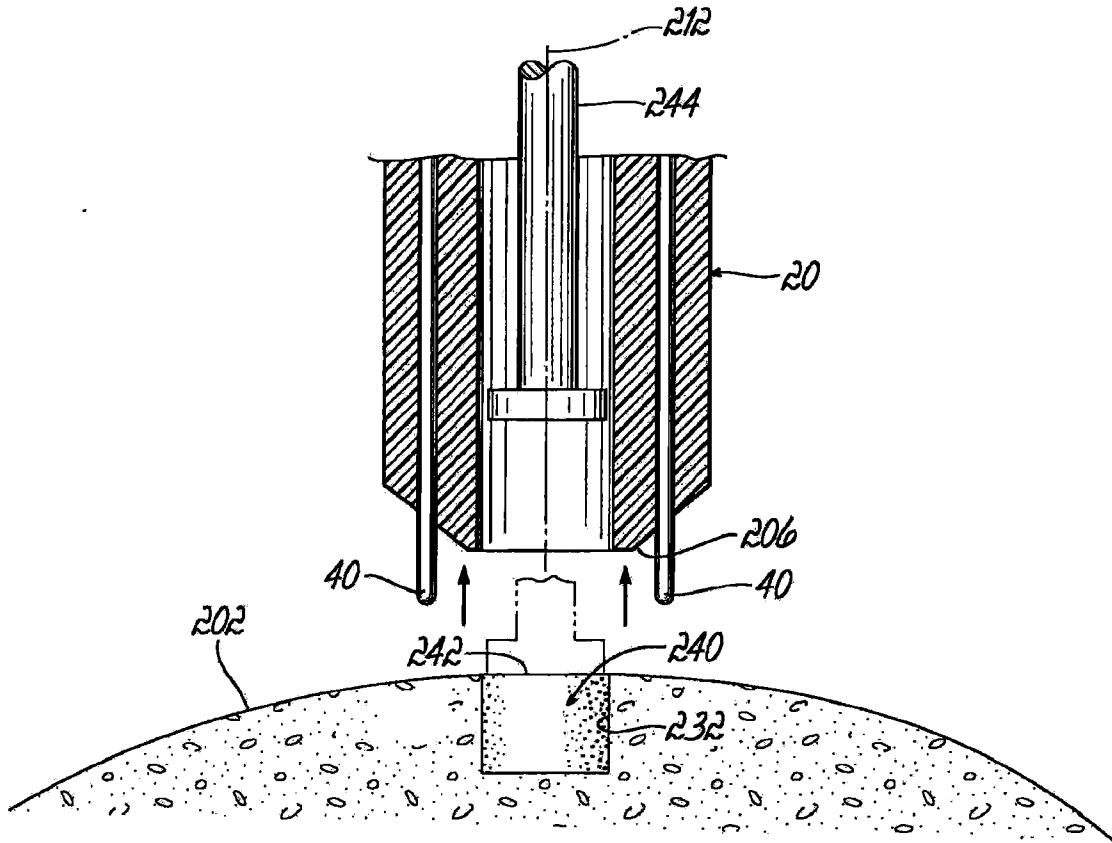

FIG. 8F

INTERNATIONAL SEARCH REPORT

International application No
PCT/US2009/036661A. CLASSIFICATION OF SUBJECT MATTER
INV. A61B17/17

According to International Patent Classification (IPC) or to both national classification and IPC

B. FIELDS SEARCHED

Minimum documentation searched (classification system followed by classification symbols)
A61B

Documentation searched other than minimum documentation to the extent that such documents are included in the fields searched

Electronic data base consulted during the international search (name of data base and, where practical, search terms used)

EPO-Internal, WPI Data

C. DOCUMENTS CONSIDERED TO BE RELEVANT

Category*	Citation of document, with indication, where appropriate, of the relevant passages	Relevant to claim No.
X	DE 28 30 566 A (GUSTAV NEUHÄUSER PRÄZISIONSWERKZEUGFABRIK) 24 January 1980 (1980-01-24) figures 1,3	1-6,8,9, 13,26-34
A	US 5 885 293 A (MCDEVITT D.) 23 March 1999 (1999-03-23) cited in the application column 8, line 23 - line 57; figures 5,12,13	1,26,28, 36
A	WO 99/21497 A (SULZER ORTHOPÄDIE) 6 May 1999 (1999-05-06) page 15, line 23 - page 16, line 14; figures 6,7	1,26,28, 36
A	page 11, line 5 - line 7	31
	-/--	

 Further documents are listed in the continuation of Box C. See patent family annex.

* Special categories of cited documents:

- *A* document defining the general state of the art which is not considered to be of particular relevance
- *E* earlier document but published on or after the international filing date
- *L* document which may throw doubts on priority claim(s) or which is cited to establish the publication date of another citation or other special reason (as specified)
- *O* document referring to an oral disclosure, use, exhibition or other means
- *P* document published prior to the international filing date but later than the priority date claimed

- *T* later document published after the international filing date or priority date and not in conflict with the application but cited to understand the principle or theory underlying the invention
- *X* document of particular relevance; the claimed invention cannot be considered novel or cannot be considered to involve an inventive step when the document is taken alone
- *Y* document of particular relevance; the claimed invention cannot be considered to involve an inventive step when the document is combined with one or more other such documents, such combination being obvious to a person skilled in the art.
- *Z* document member of the same patent family

Date of the actual completion of the international search

4 June 2009

Date of mailing of the international search report

12/06/2009

Name and mailing address of the ISA/

European Patent Office, P.B. 5818 Patentlaan 2
NL - 2280 HV Rijswijk
Tel. (+31-70) 340-2040,
Fax: (+31-70) 340-3016

Authorized officer

Nice, Philip

INTERNATIONAL SEARCH REPORT

International application No
PCT/US2009/036661

C(Continuation). DOCUMENTS CONSIDERED TO BE RELEVANT

Category*	Citation of document, with indication, where appropriate, of the relevant passages	Relevant to claim No.
A	WO 98/34569 A (SMITH & NEPHEW) 13 August 1998 (1998-08-13) page 5, line 1 - line 10; figure 2a page 8, line 1 - line 5 page 8, line 11 - line 29 page 19, line 6 - line 16; figure 13b -----	

INTERNATIONAL SEARCH REPORT

International application No.
PCT/US2009/036661

Box No. II Observations where certain claims were found unsearchable (Continuation of item 2 of first sheet)

This international search report has not been established in respect of certain claims under Article 17(2)(a) for the following reasons:

1. Claims Nos.: 38-58
because they relate to subject matter not required to be searched by this Authority, namely:
Rule 39.1(iv) PCT - Method for treatment of the human or animal body by surgery
2. Claims Nos.:
because they relate to parts of the international application that do not comply with the prescribed requirements to such an extent that no meaningful international search can be carried out, specifically:
3. Claims Nos.:
because they are dependent claims and are not drafted in accordance with the second and third sentences of Rule 6.4(a).

Box No. III Observations where unity of invention is lacking (Continuation of item 3 of first sheet)

This International Searching Authority found multiple inventions in this international application, as follows:

1. As all required additional search fees were timely paid by the applicant, this international search report covers allsearchable claims.
2. As all searchable claims could be searched without effort justifying an additional fees, this Authority did not invite payment of additional fees.
3. As only some of the required additional search fees were timely paid by the applicant, this international search report covers only those claims for which fees were paid, specifically claims Nos.:
4. No required additional search fees were timely paid by the applicant. Consequently, this international search report is restricted to the invention first mentioned in the claims; it is covered by claims Nos.:

Remark on Protest

- The additional search fees were accompanied by the applicant's protest and, where applicable, the payment of a protest fee.
- The additional search fees were accompanied by the applicant's protest but the applicable protest fee was not paid within the time limit specified in the invitation.
- No protest accompanied the payment of additional search fees.

INTERNATIONAL SEARCH REPORT

Information on patent family members

International application No

PCT/US2009/036661

Patent document cited in search report	A	Publication date	Patent family member(s)	Publication date
DE 2830566	A	24-01-1980	NONE	
US 5885293	A	23-03-1999	NONE	
WO 9921497	A	06-05-1999	EP 1027001 A1 JP 2001520911 T	16-08-2000 06-11-2001
WO 9834569	A	13-08-1998	AT 253340 T AU 733119 B2 AU 6275298 A CA 2280011 A1 DE 69819518 D1 DE 69819518 T2 EP 1006957 A1 ES 2210721 T3 US 6358253 B1 US 6146385 A	15-11-2003 10-05-2001 26-08-1998 13-08-1998 11-12-2003 23-09-2004 14-06-2000 01-07-2004 19-03-2002 14-11-2000