

H. & P. C. DUFOUR & E. B. ROWE.
Machine for Making Fence-Pickets.

No. 164,276.

Patented June 9, 1875.

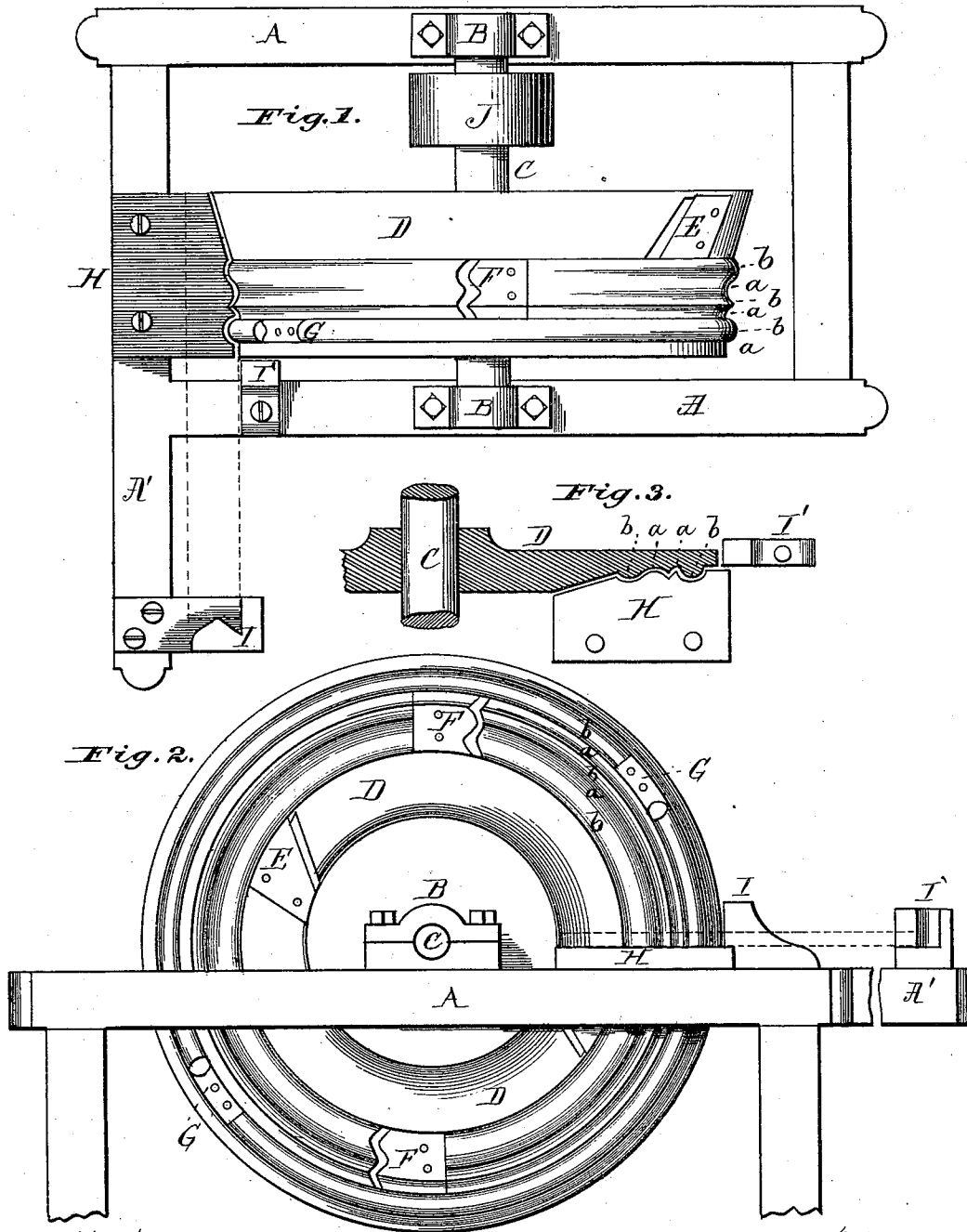

Attest:
J. S. Gould
A. H. Norris

Inventor,
Hillary and Peter C. Dufour and
Ebenzer B. Rowe
Per *James C. Norris atty.*

UNITED STATES PATENT OFFICE.

HILLARY DUFOUR, PETER C. DUFOUR, AND EBENEZER B. ROWE, OF
CHICAGO, ILLINOIS.

IMPROVEMENT IN MACHINES FOR MAKING FENCE-PICKETS.

Specification forming part of Letters Patent No. 164,276, dated June 8, 1875; application filed
September 7, 1874.

To all whom it may concern:

Be it known that we, HILLARY DUFOUR and PETER C. DUFOUR and EBENEZER B. ROWE, of Chicago, in the county of Cook and State of Illinois, have invented certain new and useful Improvements in Machines for Making Fence-Pickets, of which the following is a specification:

This invention relates to machines for making or forming fence pickets or palings, in which disks are employed which are provided with cutters for shaping the ornamental head of the picket.

The invention has for its object to render such class of machines more perfect and expeditious in operation, enabling the pickets or palings to be shaped with ease and rapidity, without liability of splitting or injuring the same while they are undergoing the cutting operation; and the invention consists in a revolving cylinder or disk, mounted upon an arbor or axis in a suitable frame, and provided with a series of cutters set into recesses in said cylinder or disk, and the cutting-edges of which are of the shape which it is desired to impart to the paling, the said disk or cylinder being provided with channels or grooves and ridges corresponding to the shape of the picket-head, whereby the latter has a firm bearing on said disk, and can be finished and dressed in a most perfect manner. The picket-head rests upon a bearing-plate, the edge of which is adjacent to the disk being shaped to correspond to the same, the two fitting comparatively close together, whereby, when the picket-head is placed thereon, and the cutters are acting, said rest offers a substantial bearing to the paling and permits the cutting operation to be effected without danger of injury to the paling, all of which will be fully hereinafter described, and pointed out in the claim.

In the drawings, Figure 1 is a plan view of our improved machine, showing the cutters set in the periphery of the disk or cylinder. Fig. 2 is an elevation showing the cutters set in the face of the cylinder or disk; and Fig. 3, a section of Fig. 2, showing the bearing-plate and stop for the picket.

The frame for supporting the cylinder or disk, designated by the letter A, may be of

any preferred construction, and is provided with bearings B B, in which the ends of a shaft, C, are journaled, the said shaft having firmly affixed to it the cylinder or disk D. This cylinder is provided with a series of knives, E F G, which are set into recesses in the said disk, and the cutting-edges of which are of the shape which it is desired to impart to the picket or paling. The cylinder or disk is also provided with grooves or channels *a*, and ridges *b*, around its periphery, as in Fig. 1, which grooves and ridges are of the shape of the picket-head it is desired to form. Upon the frame A, and immediately adjacent to the cutting cylinder or disk, is rigidly attached a plate, H, which affords a support or rest for the paling or picket while its ornamental head is being cut. The edge of said rest, which is adjacent to the cutting-disk, is of a shape corresponding to the ridges and grooves in said disk, whereby when the paling is fed toward the latter, the rest H affords a substantial bearing for the same, and permits the cutting operation to be effected with much rapidity and certainty and without the possible danger of splitting or injuring the picket-head, as in machines of this class heretofore used, in which no substantial rest or support for the picket is furnished while it is being dressed, and further, by constructing the cylinder or disk with grooves and ridges, which correspond to the shape of the ornamental picket-head, when the greater portion of the latter is cut, the ridges and portions cut away will bear against said cylinder and the paling will be held in a firm position while being finally dressed or finished, enabling this operation to be accomplished without liability of splintering or leaving rough or uneven edges. In order to provide a stop or rest for the picket to prevent its being fed too close to the cylinder, and which will also serve as a guide, we arrange a block, I, upon a prolonged arm, A', of the frame A, said stop or guide being recessed, as shown in Fig. 2, to receive the end of the picket, and upon the main frame A of the machine, we arrange a fixed stop, I', which guides and prevents the paling being fed too near the cutting-disk. The stop or rest I for the end of the picket

may be made adjustable to accommodate palings of varying length. Instead of arranging the cutters and grooves and ridges in the periphery of the disk D, as in Fig. 1, the same may be provided on one side or face of the disk, as in Figs. 2 and 3, in which case the bearing-plate H is transposed to the side of the disk, as shown, the operation, however, being the same as before described. The disk or cylinder is furnished with openings at the cutting-edge of the knives to permit the escape of chips cut from the paling. The disk is rotated in any preferred manner, the present illustration representing it as being driven by a pulley, J, on the operating-shaft.

We claim as our invention and desire to secure by Letters Patent—

The combination of the grooved and ridged revolving-cylinder, the knives having their cutting-edges shaped to correspond with the grooves and ridges, the bearing-plate H for supporting the picket while being dressed, and the combined rests and guides I I', the whole being constructed for operation, substantially as described.

In testimony that we claim the foregoing, we have hereunto set our hands.

HILLARY DUFOUR.
PETER C. DUFOUR.
EBENEZER B. ROWE.

Witnesses:

JOHN C. SCHUMACHER,
C. F. SCHUMACHER, Jr.