

Aug. 15, 1967

G. A. MACKEY

3,335,537

ROOF BATTEN OR THE LIKE

Filed July 23, 1962

2 Sheets-Sheet 1

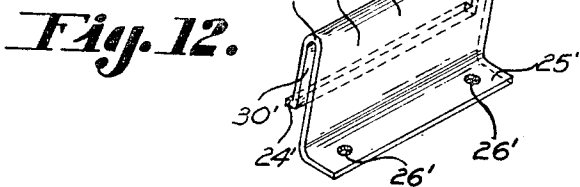
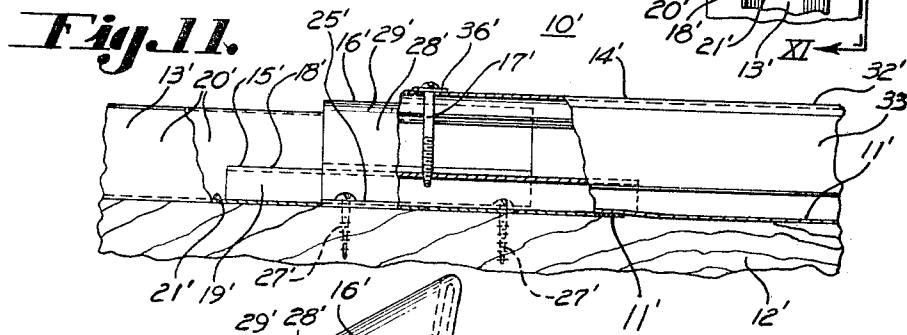
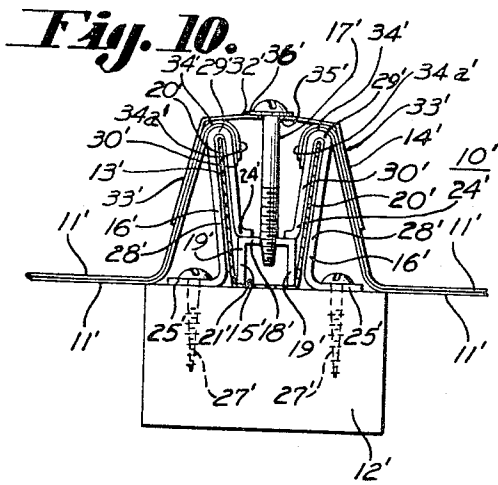
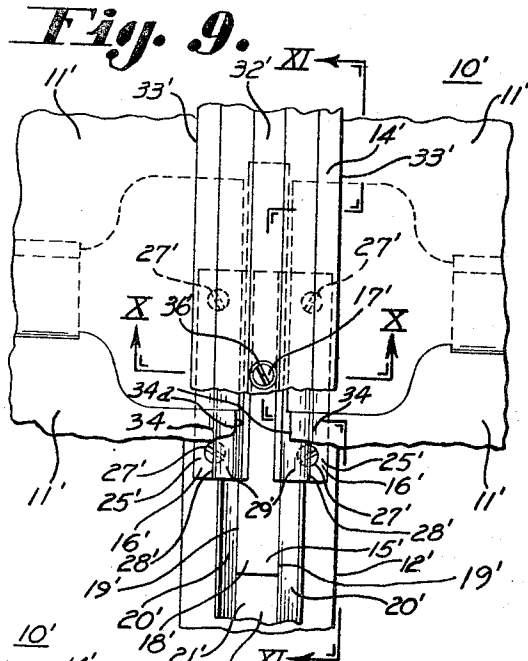
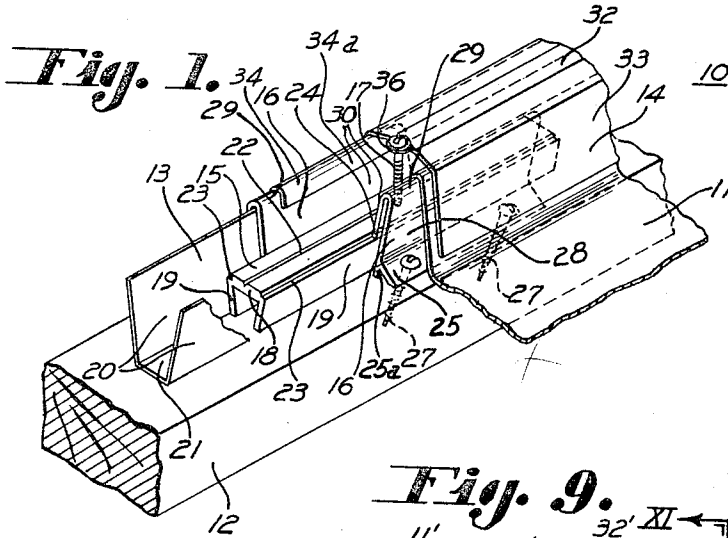

INVENTOR
GEORGE A. MACKEY
by
Hoopes, Leonard & Buell
his attorneys

Aug. 15, 1967

G. A. MACKEY

3,335,537

ROOF BATTEN OR THE LIKE

Filed July 23, 1962

2 Sheets-Sheet 2

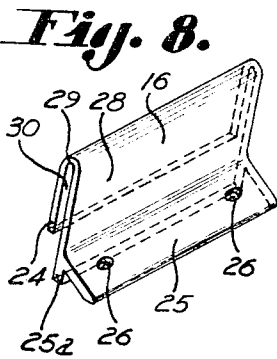
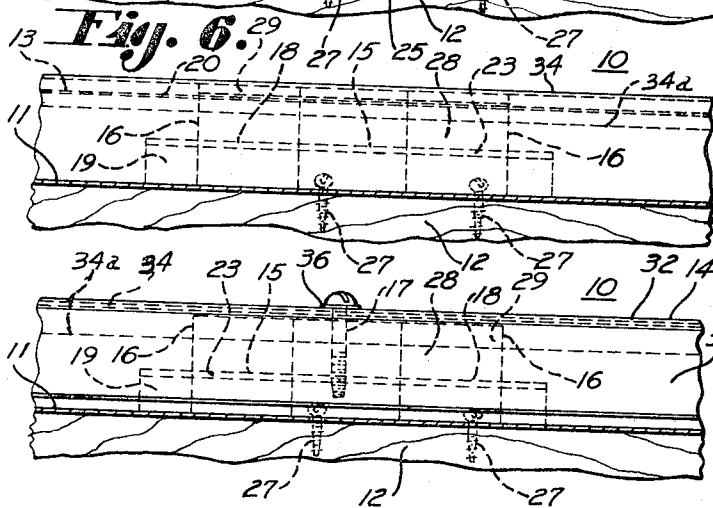
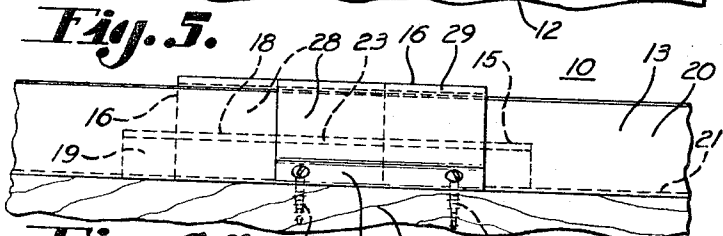
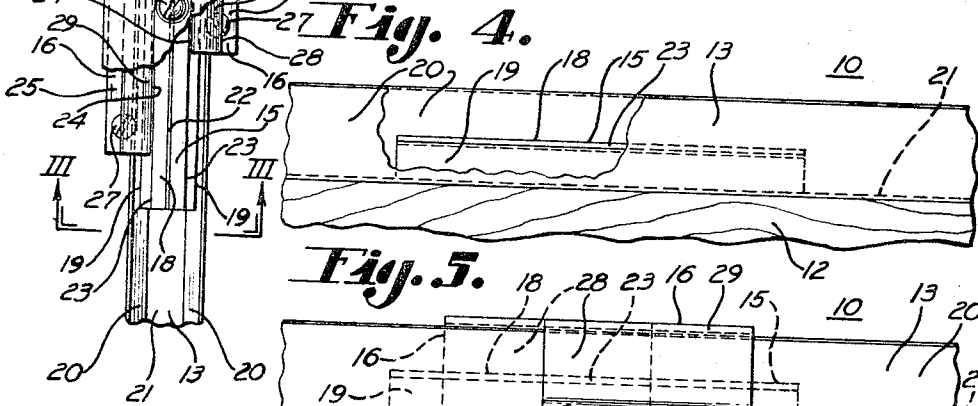
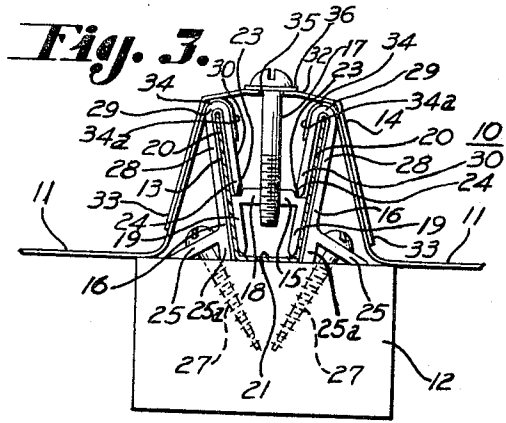
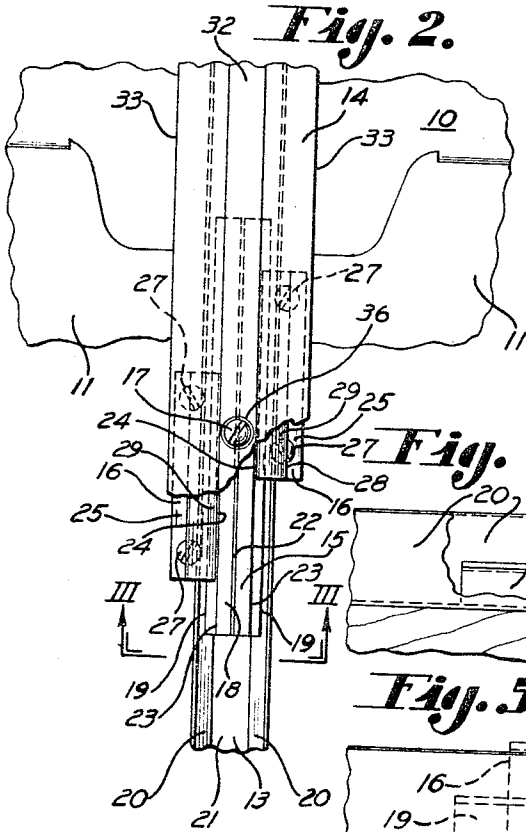

Fig. 7.

INVENTOR
 GEORGE A. MACKEY
 by Hoopes, Leonard & Buell
 his attorneys

1

2

3,335,537

ROOF BATTEN OR THE LIKE

George A. Mackey, McCandless Township, Allegheny County, Pa., assignor to Miller-Thomas-Gyekis, Inc., a corporation of Pennsylvania

Filed July 23, 1962, Ser. No. 211,808

7 Claims. (Cl. 52—463)

This invention relates to a roof batten or the like. More particularly, this invention pertains to a metal batten for a roof seam or the like in which elongated gutter and cap sections are relatively unrestrained for expansion and contraction by direct or substantially direct attachment to the roof itself without loss of watertight integrity of the battened seam, or diminution of the ability to hold roofing sheets in place.

In a practice of this invention, a system of batten roofing is provided for any sloped roof surface, such as a ridge-to-eave seam, comprising readily formed metal gutter, retainer channel, holder clips and cap sections in which gutter and cap elements are not tied to the roof construction. Thereby, gutter and cap sections are relatively unrestrained with freedom to "float" in the course of expansion and contraction of the long gutter and cap sections extending the length of the seam with their respective ends in lapped relation. At the same time, those sections are held in place in the roofing system by relatively short retainer and holder members in batten devices of this invention, the retainer also being free to move relative to the holder which provides direct attachment of the batten to the roofing construction.

Other objects, features and advantages of this invention will be apparent from the following description and the accompanying drawings, which are illustrative only, in which:

FIGURE 1 is a view in perspective of one embodiment of this invention with portions broken away to clarify the structure there shown;

FIGURE 2 is a plan view of the embodiment illustrated in FIGURE 1 with a portion of the cap element removed for clarity;

FIGURE 3 is a view in elevation viewed in the direction of line III—III of FIGURE 2;

FIGURE 4 is a view in side elevation of the gutter and retainer element in assembled position in the foregoing embodiment;

FIGURE 5 is a view similar to that shown in FIGURE 4 with the holder elements added;

FIGURE 6 is the same as FIGURE 5 with the addition that the margin of the nearer roofing sheet has been shown alongside the batten with the inner edge of the roofing sheet hooked over and bent down within the gutter;

FIGURE 7 shows the completed batten of the aforesaid embodiment with the cap element in place and secured by a fastener screw to the retainer;

FIGURE 8 is a detail view of the holder clip used in the embodiment of FIGURES 1 to 7, inclusive, formed of extruded metal;

FIGURE 9 is a plan view showing a further embodiment of this invention;

FIGURE 10 is a view in cross section of such further embodiment taken along line X—X of FIGURE 9;

FIGURE 11 is a view in side elevation of such further embodiment, with parts broken away, taken generally in the direction of line XI—XI of FIGURE 9; and

FIGURE 12 is a detail view of a holder clip used in such further embodiment and made of formed sheet metal.

Referring to FIGURES 1 to 8, inclusive, there is shown therein a combination batten 10 utilized to provide a roof seam, such as one from ridge to eave on a sloped roof,

which binds and covers the adjoining edges of metal roofing sheets 11 to each side thereof in a roofing system.

As shown, each batten 10 is fastened to a rafter beam 12 and includes an elongated trough-shaped gutter section 13, an elongated inverted trough-shaped cap section 14, a retainer element 15, preferably in channel form, holder members 16 adapted to be secured to the roofing construction and fasteners, which may be in the form of bolts or screws 17 to fasten the cap sections along the length of the seam to the respective retainers 15. Generally, for longer seams, a plurality of trough sections 13 and cap sections 14 will be utilized in end-to-end lapped relation with the lower end of the immediately higher section on a sloped roof being telescoped over the upper end of the next lower section, respectively, swaging commonly being used to provide good fit at the laps. As an example, such gutter and cap lengths may be ten to fifteen feet long, whereas retainer members 15 may be about six inches long and spaced eighteen inches apart in the continuous gutter along the length of the battened seam. Preferably a pair of holder clips 16 is used for each retainer 15, although a different number may be utilized if desired.

In the embodiment being described, the batten parts are of any suitable metal compatible with other parts and for the service in which they are to be used. As shown, the gutter and cap members 13 and 14 are of light gauge sheet metal which is pressed or rolled to the desired shape which, as shown, has the respective sides flaring, upwardly in the case of gutter 13 and downwardly in the case of cap 14. Channel 15 and clips 16, on the other hand, as shown, are of compatible extruded metal for rigidity and strength. Channel 15 has a top or web portion 18 and flange or leg portions 19 which converge downwardly to suit the slope of the sides 20 of gutter 13 while the bottom edges of the legs 19 engage the flat bottom 21 of gutter 13. Being of channel shape, retainer 15 does not impede the draining away of any moisture which may get up under cover 14 and into gutter 13. Water passes through gutter 13 to the eave where it is discharged, e.g., into an eave gutter.

Web 18 is provided with a longitudinally extending central groove 22 on the upper surface thereof for ready centering of a drill used to drill a hole or holes through the top of cap 14 and into the center of web 18 for a screw fastener 17, each hole made in web 18 usually being tapped following such drilling unless screw 17 is a self-tapping screw. If desired, the cap lengths 14 may have the holes therein for fasteners 17 made before the battens are assembled at the site where they are to be used, although the web 18 usually will be drilled and tapped on the site as a simpler act than trying to bring preformed fastener holes in cap 14 and retainer 15 into registry. Each web 18 in the first embodiment is also provided with a rabbet or recess 23 at each upper corner to seat the respective inner edges 24 of the holder clips 16.

Each clip 16 is generally L-shaped in cross section and provided with a base or foot 25 having holes 26 therein for fasteners such as wood screws 27 to affix clips 16 directly to rafter beam 12 in the roofing construction. The bases 25 are sloped laterally downwardly and outwardly when wood screws 27 are to be toed in for increased holding power. The clips 16 are preferably longitudinally displaced in that case as shown in FIGURE 2, so that the screws 27 on one side are longitudinally offset from the screws 27 on the opposite side, thereby retaining full holding power despite the end view convergence of such screws toward a vertical central longitudinal plane through the axes of fasteners 17. Each base 25 is provided with a heel 25a for more secure affixation and predetermined positioning of clips 16 to the roofing construction. Each clip rises from its base in an outer wall portion 28

paralleling the adjacent side 20 of gutter 13 and then makes a reentrant turn 29 at the top of the clip to start a downwardly extending inner wall 30 parallel to the other side of the adjacent side 20 of gutter 13, such inner wall terminating at its lower end in the edge 24.

In use, a batten 10 is assembled at the site of use and gutter 13 is held down in the illustrated embodiment by a plurality of channels 15 in longitudinally spaced relation inside gutter 13, each channel being held in turn by affixing clips 16 tied to the roofing construction 12 by screws 27. The edges 24 of clips are seated in the corner recesses 23 of retainer 15, thus providing minimal friction and aligned relative movement of parts in batten 10 under expansion and contraction forces because the surface area in engagement between clips 16 and channel 15 is relatively small and tends toward a line type of contact. At the same time, the length of contact between clips 16 and their channel 15 insures relatively aligned movement therebetween. Further, the channels 15 in trough 13 are preferably spaced from sides 20 and have relatively small area engagement between the bottom of legs 19 and bottom 21 of the gutter. The roofing sheets 11 to each side of the batten are bent up at margins 34 and then hooked down as indicated at 34a over each of the upstanding sides of the batten gutters and clips beneath cover 14. The cap section or sections 14 comprise the cover of batten 10 from one end to the other by means of the arch or inverted trough provided by top portion 32 and integral sides 33 which flare somewhat outwardly in a downwardly direction to lie close to or against the bent-up margins 34 of the roof sheets 11. Screws 17 are then inserted at longitudinally spaced intervals generally corresponding to the centers of the spaced channels 15, the screws 17 being inserted either through pre-punched holes along the "ridge" of the cap piece, or through such holes drilled at the time of drilling of at least one hole 35 in each channel 15 as described above, to engage the lower threads of screw fastener 17 and retain cap 14 in place without being immovably affixed relative. A gasket 36 may be placed under the head of screw 17 before it is inserted and tightened to bind the batten assembly together and the hooked portion 34a of the roofing sheets 11 between the underside of the cap 14 and the upper edges of sides 20, or the respective bends 29 of clips 16. The cap sections 14, like the gutter sections, are preferably of light gauge sheet metal which also may be formed by a press brake, or those members may be extruded or otherwise shaped, if desired. The roofing sheets 11 preferably have lap lock-type transverse seams cleated to the roofing base with the lower edge of higher roof sheets overlying the upper transverse edges of the next lower roofing sheets to provide a watertight cover for the roof or other system being protected. Thus, any water which may work its way into the interior of a batten 10 over the surface of the roofing sheets will pass into trough 13 and flow down through the continuous length thereof to discharge at its lower end.

Other variants of the illustrated embodiment are possible including ones in which each gutter length 13 is held by engagement between the upper edges of sides 20 and the inside of the bends 29 of the clips 16. Similarly, such further variant may utilize a retainer 15 which abuts the lower edges 24 of the clip 16 when a screw 17 is tightened without the retainer having legs 19 in such case to press against bottom 21 of gutter 13. And, the clips 16 may be positioned directly opposite to one another, particularly if the securing screws 27 are not toed in, or toed in to a lesser extent than shown in the first embodiment. And, other forms and kinds of fasteners than those illustrated as wood and machine screws may be utilized in securing battens of this invention, in which only holders 16 are immovably fixed to the roofing construction, although all of the members of a roof batten or the like of this invention are held in place because of its construction, leaving the gutter, retainer and cap members relatively

unrestrained for longitudinal movement arising out of temperature changes or other factors resulting in expansion and/or contraction of one or more of the parts of the new devices and therefore less subject to undue stress, strain and/or buckling.

In the second embodiment of FIGURES 9 to 12, inclusive, all parts of batten 10' may be made by forming operations other than extrusion and parts of such second embodiment corresponding generally in construction and functioning to parts of the first-above described embodiment are provided with the same reference numerals with the addition of a prime accent thereto, respectively. In batten 10', clips 16' have flat rather than inclined feet or flanges 25' and screw fasteners 27' are substantially parallel to a vertical plane through the axes of the cap and retainer fasteners 17'. Further, channel 15' is of a simpler and cheaper construction than channel 15 being of a more regular box shape, or a generally rectangular tube is utilizable as channel 15' resting on bottom 21' of gutter 13'. Clips 16' also are provided with inwardly turned edges 24' to bear on the upper side of the respective upper corners of channel 15' and press it against bottom 21'. The clips 16' are directly opposed to one another as may be seen in FIGURES 9 and 11 and the particular portion of batten 10' shown has them positioned at a location in which a double thickness of roofing sheets 11' is present because of a transverse lap at a transverse seam, the lap being such that the lower transverse edges of the immediately upper sheets 11' overlie the upper edges of the immediately lower sheets 11'. Batten members of this invention also may be made of a suitable material other than metal, such as structural nylon.

Various changes may be made in details of the illustrated embodiments and other embodiments provided without departing from the spirit of this invention or the scope of the appended claims.

I claim:

1. A roof batten or the like, comprising, in combination, an elongated sheet metal gutter with upstanding flared sides and a flat bottom, a relatively short channel having its web generally parallel to said bottom and its legs extending downwardly into engagement with said bottom, a relatively short holder clip on each side of said gutter positioned laterally within the distance between the ends of said channel, each clip having a base adapted to be affixed to a roof or the like outside of said gutter, an upwardly extending outer wall generally paralleling the adjacent side of said gutter, and a downwardly extending inner wall forming a reentrant bend at the top with said outer wall which extends over said adjacent side and generally parallels said adjacent side of said gutter, the inside of said reentrant bend being spaced above the upper edge of said adjacent side, the lower end of said inner wall frictionally engaging the nearer upper corner of said channel, an elongated sheet metal cap covering said gutter and clips and having downwardly extending flared sides, means for fastening said cap to respective longitudinally spaced channels between said lower ends of said inner walls, the underside of said cap being adapted to bind margins of roofing sheets or the like against the outside of said bends of said clips, and at least one cap fastener for each channel to fasten said cap to a plurality of channels respectively along the length of said cap.

2. A roof batten or the like as set forth in claim 1, comprising, said clips being extrusions, said bases of said clips being inclined downwardly and outwardly to permit screw fasteners to be toed-in in affixing said clips to a roof or the like, said channel being an extrusion, said channel further having a longitudinally extending recess adjacent the upper corner on each side of said web for the seating of said respective lower ends of said clips cooperating therewith, and, a longitudinally extending

central groove in the upper surface of said web for ready location and engagement of said cap fastener.

3. A roof batten or the like as set forth in claim 1, comprising, said gutter, channel clip and cap means being of formed metal, said gutter and cap means extending for the length of a seam on a sloping roof or the like and comprising a plurality of elongated sections in lap relation at the respective ends of adjoining sections, said channel and clip means being relatively short and in longitudinally spaced arrangement along said gutter and cap means, each clip means for each channel comprising a pair of clips on generally opposite sides of said gutter to arch over the sides of said gutter and engage said channel, said channel having downwardly extending legs engaging the bottom of said gutter, and said engagement between said clip and channel means and between said channel and gutter means being substantially line contact in the direction of said seam.

4. A roof batten or the like as set forth in claim 3, comprising said gutter being of trough shape in cross section, said cap being of inverted trough shape in cross section, said channel being positioned wholly within the lower portion of said gutter, said clip being generally L-shaped in cross section with a hook portion on the back thereof to engage the adjacent side of said channel respectively inside said gutter, the foot of said clip outside of said gutter being adapted to be fastened to a roof or the like to hold down said channel and in turn to hold said gutter against said roof or the like.

5. A roof batten or the like comprising, in combination, a gutter with upwardly extending sides, retainer means in said gutter, holder means separated from said retainer means and adapted to be fastened to a roof or the like and reach over the sides of said gutter and frictionally hold said retainer means at least against upward movement, the holder means having means holding down the retainer means while permitting movement of the retainer means in a direction along the gutter, and cap means fastened to said retainer means and adapted to press sheet material against said holder means, whereby said gutter and retainer means are held without direct attachment to a roof or the like and may expand and contract relatively unrestrained when said holder means is affixed to said roof or the like outside of said gutter, said gutter and cap means adapted to extend for the length of a seam on a roof or the like and comprising a plurality of elongated sections in lap relation at the respective ends of adjoining sections, said retainer and holder means being shorter than said gutter and in longitudinally spaced arrangement along said gutter and cap means sections, each hold-

er means for each retainer means adapted to be fastened on the outside of opposite sides of said gutter and to reach into said gutter to engage said retainer means, and fastener means extending between said cap means and said retainer means.

6. A roof batten or the like as set forth in claim 5, comprising, said gutter, retainer, holder and cap means being of formed metal, said gutter being of trough shape in cross section, said cap means being of inverted trough shape in cross section, said retainer means being positioned wholly within the lower portion of said gutter, said holder means being respective clips with a hook portion at the top thereof to reach over said gutter and engage the adjacent sides of said retainer means respectively inside said gutter, said clips being adapted to be fastened to the roof or the like outside of said gutter to hold down said channel and in turn to hold said gutter against said roof or the like, and a fastener extending between the said cap means and the top of said retainer means generally between said clips.

7. A roof batten or the like, comprising, in combination, an elongated gutter with upstanding sides and a bottom, a relatively short retainer within said gutter extending downwardly into frictional engagement with a lower portion of said gutter, a separate relatively short holder on each side of said gutter positioned alongside said retainer, each holder being adapted to be affixed to a roof or the like outside of said gutter and having an upwardly and generally outwardly extending outer wall and a downwardly extending inner wall forming a reentrant bend at the top with said outer wall which extends over an adjacent side of said gutter, said inner wall being adapted to frictionally engage said retainer, said inner wall having means holding down the retainer while permitting relative movement between the retainer and the holder in a direction along the gutter, an elongated cap adapted to cover said gutter and holders having downwardly extending sides and at least one cap fastener for each retainer to fasten said cap thereto respectively along the length of said batten.

References Cited

UNITED STATES PATENTS

2,907,287	10/1959	Trostle	52-409
3,055,147	9/1962	Goodwin	52-463

DAVID J. WILLIAMOWSKY, *Primary Examiner.*

JACOB SHAPIRO, JACOB L. NACKENOFF, EARL J. WITMER, *Examiners.*