



12

EUROPEAN PATENT SPECIFICATION

45 Date of publication of patent specification :
04.10.95 Bulletin 95/40

51 Int. Cl.⁶ : **H05B 6/70, H05B 6/80**

21 Application number : **91106064.8**

22 Date of filing : **16.04.91**

54 **High frequency heating apparatus.**

30 Priority : **25.04.90 JP 109531/90**

43 Date of publication of application :
30.10.91 Bulletin 91/44

45 Publication of the grant of the patent :
04.10.95 Bulletin 95/40

84 Designated Contracting States :
DE FR GB

56 References cited :
EP-A- 0 199 264
EP-A- 0 373 608
JP-A-61 036 622

73 Proprietor : **KABUSHIKI KAISHA TOSHIBA**
72, Horikawa-cho,
Saiwai-ku
Kawasaki-shi, Kanagawa-ken 210, Tokyo (JP)

72 Inventor : **Kawai, Yasuhiko**
3-80, Kumata-Cho,
Sohara
Kakamigahara-Shi, Gifu-Ken (JP)

74 Representative : **Liesegang, Roland, Dr.-Ing. et**
al
FORRESTER & BOEHMERT
Franz-Joseph-Strasse 38
D-80801 München (DE)

EP 0 453 928 B1

Note : Within nine months from the publication of the mention of the grant of the European patent, any person may give notice to the European Patent Office of opposition to the European patent granted. Notice of opposition shall be filed in a written reasoned statement. It shall not be deemed to have been filed until the opposition fee has been paid (Art. 99(1) European patent convention).

Description

The present invention relates to a high frequency heating apparatus. More particularly, the present invention relates to a high frequency heating apparatus including a magnetron wherein a microwave generated by an antenna of the magnetron with a high frequency can effectively be conducted to the interior of a heating chamber through a wave guide tube having an improved structure.

EP-A-199 264 discloses an apparatus having a wave guide which extends across the excitation aperture and is integrally attached to the outer surface of the upper portion of the side wall of the oven casing.

To facilitate understanding of the present invention, a typical conventional high frequency heating apparatus (hereinafter referred to simply as an apparatus) will briefly be described below with reference to Fig. 3. As shown in the drawing, an oven casing 4 is arranged in the interior of a housing 1 and an instrument chamber 6 is installed on one side (right-hand side in the shown case) of the oven casing 4. The oven casing 4 is formed with an excitation aperture 7 on a side wall 4a of the oven casing 4 on the instrument chamber 6 side.

A wave guide tube 8 is integrated with the side wall 4a of the oven casing 4 while extending across the excitation aperture 7. In addition, a magnetron 9 is arranged at the position substantially corresponding to the uppermost end of the wave guide tube 8 such that an antenna 9a of the magnetron 9 is protruded into the interior of the wave guide tube 8. Further, a high voltage transformer 10 is installed on a bottom plate 1a of the housing 1 on the instrument chamber 6 side. As is apparent from the drawing, the transformer 10 is located below the wave guide tube 8 and the magnetron 9. A vibration proof rubber 11 is interposed between the transformer 10 and the side wall 4a of the oven casing 4 so as to absorb vibrations of the side wall 4a of the oven casing 4 induced by a leakage flux appearing instantaneously when the transformer 10 is activated by an electric current.

When a cooking operation is performed with the conventional apparatus as constructed in the above-described manner, the magnetron 9 is activated by an electric current to generate a microwave having a high frequency with the aid of an antenna 9a. Then, the microwave is conducted to the interior of the heating chamber 5 via the wave guide tube 8 and the excitation aperture 7, whereby a food W to be cooked is heated in the heating chamber 5.

However, with respect to the conventional apparatus, since the wave guide tube 8 is arranged in the space above the transformer 10, the wave guide tube 8 can not be constructed with a sufficiently long distance in the direction of propagation of the microwave. This leads to the result that the lower end of the wave guide tube 8 substantially coincides with the

lower edge of the excitation aperture 7. For this reason, it is difficult to obtain proper impedance matching between the heating chamber 5 and the wave guide tube 8 and moreover there is a possibility that electric discharge occurs at the antenna 9a of the magnetron 9. In addition, since the transformer 10 is installed directly opposite to the side wall 4a of the oven casing 4, the apparatus can not avoid vibrations induced by repeated magnetic pulling and pushing of the side wall 4a of the oven casing 4 due to the leakage flux appearing instantaneously when the transformer 10 is activated by an electric current. Therefore, the vibration proof rubber 11 should be interposed between the transformer 10 and the side wall 4a of the oven casing 4 so as to absorb the vibrations.

The present invention has been made with the foregoing background in mind.

EP-A-373 608 (prior art according to Art. 54(3) EPC) discloses a high frequency heating apparatus including an oven casing of which interior serves as a heating chamber, the oven casing being formed with an excitation aperture on a side wall thereof, and a wave guide tube integrated with the side wall of the oven casing while extending across the excitation aperture, wherein

the wave guide tube is integrally attached to the outer surface of the side wall of the oven casing within the range from the upper end to the lower end of the oven casing, and

a high voltage transformer is installed on the bottom plate of a housing outside of the oven casing and facing the lower end part of the wave guide tube.

An object of the present invention is to provide a high frequency heating apparatus which assures that proper impedance matching can easily be obtained between a heating chamber and a wave guide tube.

Another object of the present invention is to provide a high frequency heating apparatus which assures that an occurrence of vibration of the side wall of an oven casing due to a leakage flux appearing instantaneously when a high voltage transformer is activated by an electric current can reliably be prevented without any necessity for interposing a vibration proof rubber between the transformer and the side wall of the oven casing.

To accomplish the above objects, the present invention provides a high frequency heating apparatus of claim 1.

According to the present invention, the wave guide tube is integrally attached to the side wall of the oven casing while extending across the excitation aperture within the range from the upper end to the lower end of the oven casing. With this construction, a sufficiently long distance can be assured within the range from the excitation aperture to the lower end of the wave guide tube with the result that proper impedance matching can easily be obtained between the heating chamber and the wave guide tube. In addi-

tion, since a part of the wave guide tube is fixedly attached to the side wall of the oven casing in the region opposite to the high voltage transformer, the side wall of the oven casing is reinforced with the wave guide tube. This leads to the result that an occurrence of vibration of the oven casing due to a leakage flux appearing instantaneously when the transformer is activated by an electric current can be prevented reliably. Further, an assembling operation can easily be performed without any necessity for interposing a vibration proof rubber between the transformer and the oven casing. Consequently, a number of high frequency heating apparatuses can be fabricated on mass production line at a reduced cost.

Other objects, features and advantages of the present invention will become apparent from reading of the following description which has been made in conjunction with the accompanying drawings.

The present invention is illustrated in the following drawings.

Fig. 1 is a sectional front view of a high frequency heating apparatus in accordance with an embodiment of the present invention.

Fig. 2 is a perspective view which shows an appearance of the high frequency heating apparatus in Fig. 1

Fig. 3 is a sectional front view of a conventional high frequency heating apparatus.

Now, the present invention will be described in detail hereinafter with reference to the accompanying drawings which illustrates a high frequency heating apparatus (hereinafter referred to simply as an apparatus) in accordance with an embodiment of the present invention.

In Fig. 1 and Fig. 2, reference numeral 1 designates a housing which is constructed in the box-shaped configuration. An opening/closing door 2 and a control panel 3 are arranged on the front surface of the housing 1. In addition, an oven casing 4 is arranged in the housing 1 so as to allow the interior of the oven casing 4 to serve as a heating chamber 5. The housing 1 includes an instrument chamber 6 on one side (right-hand side in the shown case) of the housing 1. The oven casing 4 is formed with an excitation aperture 7 on a side wall 4a of the oven casing 4 on the instrument chamber 6 side.

A wave guide tube 12 is integrated with the side wall 4a of the oven casing 4 while extending across the excitation aperture 7 within the range from the upper and to the lower end of the oven casing 4 in the substantially vertical direction. Further, the apparatus is provided with a magnetron 9 at the position in the vicinity of the upper end 12a of the wave guide tube 12 such that an antenna 9a of the magnetron 9 is protruded into the interior of the wave guide tube 12 to generate a microwave having a high frequency.

A vertical distance as measured from the center of the antenna 9a to the lower end 12b of the wave

guide tube 12 is represented by D. According to the present invention, this vertical distance D can be dimensioned longer than the vertical distance d of the conventional apparatus which has been described above with reference to Fig. 3. In practice, the dimensioning of the vertical distance D in that way makes it easier to obtain proper impedance matching between the heating chamber 5 and the wave guide tube 12 by adequately adjusting the vertical distance D.

A high voltage transformer 10 is mounted on a bottom plate 1a of the housing 1 in the spaced relationship relative to the lower end 12b of the wave guide tube 12 with a certain distance therebetween. A height h of the wave guide tube 12 at the lower end 12b thereof is dimensioned smaller than a height H of the same at the upper end 12a, as shown in Fig. 1.

As described above, according to the present invention, the wave guide tube 12 is integrated with the side wall 4a of the oven casing 4 while extending across the excitation aperture 7 and a vertical distance as measured from the center of the excitation aperture 7 to the lower end 12b of the wave guide tube 12 is dimensioned sufficiently long. Thus, the construction of the apparatus as mentioned above makes it easier to obtain proper impedance matching between the heating chamber 5 and the wave guide tube 8. In addition, since the wave guide tube 12 is integrated with the side wall 4a in that way, this assures that vibrations of the side wall 4a of the oven casing 4 induced by a leakage flux appearing instantaneously when the transformer 10 is activated by an electric current can reliably be absorbed by the apparatus.

While the present invention has been described above with respect to a single preferred embodiment, it should of course be understood that the present invention should not be limited only to this but various changes or modifications may be made without departure from the scope of the invention as defined by the appended claims.

Claims

1. A high frequency heating apparatus including an oven casing (4) of which interior serves as a heating chamber (5), the oven casing (4) being formed with an excitation aperture (7) on a side wall (4a) thereof, and a wave guide tube (12) integrated with the side wall (4a) of the oven casing (4) while extending across the excitation aperture (7), wherein
 - a) the wave guide tube (12) is integrally attached to the outer surface of the side wall (4a) of the oven casing (4) within the range from the upper end to the lower end of the oven casing (4),

b) a high voltage transformer (10) is installed on the bottom plate (1a) of a housing (1) outside of the oven casing (4) and facing the lower end part (12b) of the wave guide tube (12), and

c) a height of part of the wave guide tube (12) arranged opposite to the high voltage transformer (10) is dimensioned much smaller than a height of the remaining part of the wave guide tube (12).

2. A high frequency heating apparatus as claimed in claim 1, characterized in that the wave guide tube (12) extends in the substantially vertical direction within the range from the upper end to the lower end of the side wall (4a) of the oven casing (4).

Patentansprüche

1. Hochfrequenz-Heizvorrichtung, mit einem Ofengehäuse (4), dessen Inneres als eine Heizkammer (5) dient, wobei das Ofengehäuse (4) mit einer Anregungsöffnung (7) an einer Seitenwand (4a) des Gehäuses ausgebildet ist, und mit einem Wellenleiterrohr (12), das in die Seitenwand (4a) des Ofengehäuses (4) integriert ist, während es sich über die Anregungsöffnung (7) erstreckt, bei der

a) das Wellenleiterrohr (12) an die Außenfläche der Seitenwand (4a) des Ofengehäuses (4) innerhalb des Bereiches vom oberen Ende zum unteren Ende des Ofengehäuses (4) angebaut ist,

b) ein Hochspannungstransformator (10) an der Bodenplatte (1a) eines Gehäuses (1) außerhalb des Ofengehäuses (4) montiert ist, der zu dem unteren Endteil (12b) des Wellenleiterrohres (12) hinweist, und

c) eine Höhe eines Teils des Wellenleiterrohres (12), welcher dem Hochspannungstransformator (10) gegenüber angeordnet ist, wesentlich geringere Abmessungen aufweist als eine Höhe des übrigen Teils des Wellenleiters (12).

2. Hochfrequenz-Heizvorrichtung nach Anspruch 1, dadurch gekennzeichnet, daß das Wellenleiterrohr (12) sich im wesentlichen in vertikaler Richtung innerhalb des Bereiches von dem oberen Ende zu dem unteren Ende der Seitenwand (4a) des Ofengehäuses (4) erstreckt.

Revendications

1. Un appareil de chauffage à hautes fréquences qui inclut une enveloppe (4) de four dont l'intérieur sert de chambre chauffante (5), une ouver-

ture d'excitation (7) étant ménagée dans l'enveloppe (4) du four sur une paroi latérale (4a) de cette dernière, et un tube guide d'ondes (12) étant intégré à la paroi latérale (4a) de l'enveloppe du four en s'étendant en travers de l'ouverture d'excitation (7), dans lequel

a) le tube guide d'ondes (12) est attaché d'un seul tenant à la surface extérieure de la paroi latérale (4a) de l'enveloppe (4) du four à l'intérieur de la plage comprise entre l'extrémité supérieure et l'extrémité inférieure de l'enveloppe (4) du four,

b) un transformateur à haute tension (10) est installé sur la plaque inférieure (1a) d'un boîtier (1) à l'extérieur de l'enveloppe (4) du four et fait face à la partie (12b) d'extrémité inférieure du tube guide d'ondes (12), et

c) une hauteur d'une partie du tube guide d'ondes (12) agencée à l'opposé du transformateur à haute tension (10) est dimensionnée de manière à être beaucoup plus petite qu'une hauteur de la partie restante du tube guide d'ondes (12).

2. Un appareil de chauffage à hautes fréquences selon la revendication 1 caractérisé en ce que le tube guide d'ondes (12) s'étend dans la direction sensiblement verticale à l'intérieur de la plage comprise entre l'extrémité supérieure et l'extrémité inférieure de la paroi latérale (4a) de l'enveloppe (4) du four.

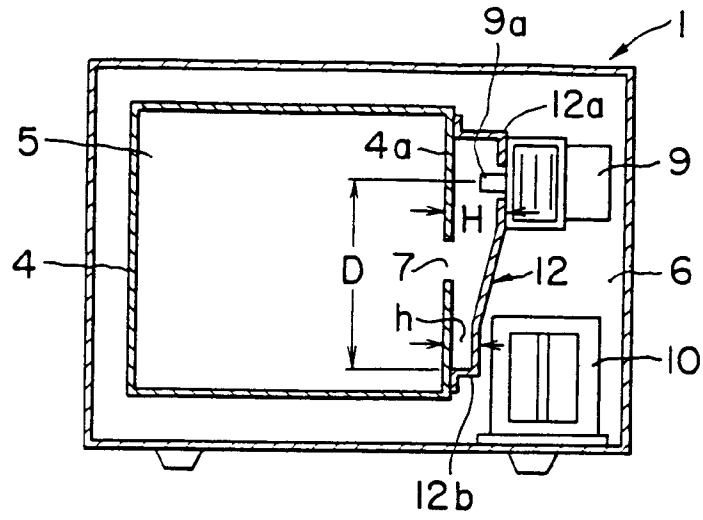

FIG. 1

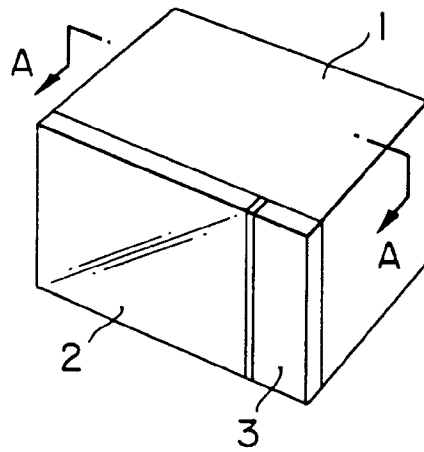

FIG. 2

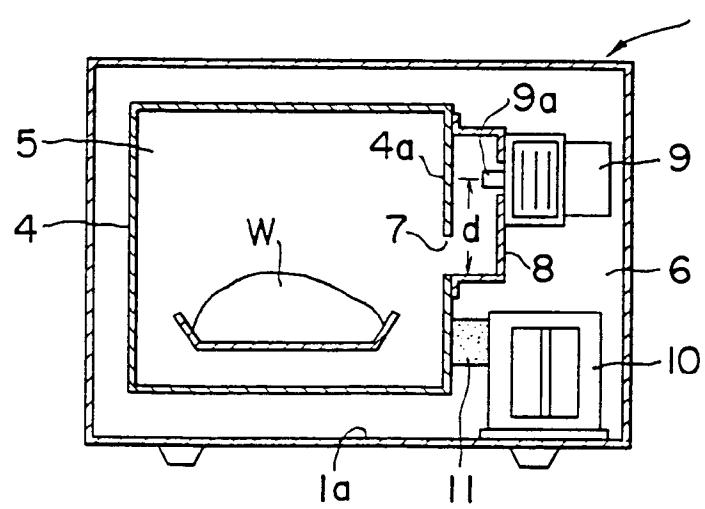

FIG. 3