

(12) INTERNATIONAL APPLICATION PUBLISHED UNDER THE PATENT COOPERATION TREATY (PCT)

(19) World Intellectual Property Organization  
International Bureau



(43) International Publication Date  
11 October 2001 (11.10.2001)

PCT

(10) International Publication Number  
**WO 01/75698 A2**

- (51) International Patent Classification<sup>7</sup>: **G06F 17/60**
- (21) International Application Number: PCT/GB01/01349
- (22) International Filing Date: 27 March 2001 (27.03.2001)
- (25) Filing Language: English
- (26) Publication Language: English
- (30) Priority Data:  
0007403.9 27 March 2000 (27.03.2000) GB
- (71) Applicant (for all designated States except US): **BP AMOCO PLC** [GB/GB]; Britannic House, 1 Finsbury Circus, London EC2M 7BA (GB).
- (72) Inventors; and
- (75) Inventors/Applicants (for US only): **TAURANAC, Julie** [GB/GB]; 38A Hersham Road, Walton-on-Thames, Surrey KT12 1JH (GB). **WYLIE, Ian, Cameron** [GB/US]; 41W155 Oak Hills Crescent, Elburn, IL 60119 (US).
- (74) Agent: **HYMERS, Ronald, Robson**; BP International Limited, Patents & Agreements, Chertsey Road, Sunbury-on-Thames, Middlesex TW16 7LN (GB).
- (81) Designated States (national): AE, AG, AL, AM, AT, AU, AZ, BA, BB, BG, BR, BY, BZ, CA, CH, CN, CO, CR, CU, CZ, DE, DK, DM, DZ, EE, ES, FI, GB, GD, GE, GH, GM, HR, HU, ID, IN, IS, JP, KE, KG, KP, KR, KZ, LC, LK, LR, LS, LT, LU, LV, MA, MD, MG, MK, MN, MW, MX, MZ, NO, NZ, PL, PT, RO, RU, SD, SE, SG, SI, SK, SL, TJ, TM, TR, TT, TZ, UA, UG, US, UZ, VN, YU, ZA, ZW.
- (84) Designated States (regional): ARIPO patent (GH, GM, KE, LS, MW, MZ, SD, SL, SZ, TZ, UG, ZW), Eurasian patent (AM, AZ, BY, KG, KZ, MD, RU, TJ, TM), European patent (AT, BE, CH, CY, DE, DK, ES, FI, FR, GB, GR, IE, IT, LU, MC, NL, PT, SE, TR), OAPI patent (BF, BJ, CF, CG, CI, CM, GA, GN, GW, ML, MR, NE, SN, TD, TG).
- Declaration under Rule 4.17:**  
— of inventorship (Rule 4.17(iv)) for US only
- Published:**  
— with declaration under Article 17(2)(a); without abstract; title not checked by the International Searching Authority
- For two-letter codes and other abbreviations, refer to the "Guidance Notes on Codes and Abbreviations" appearing at the beginning of each regular issue of the PCT Gazette.



**WO 01/75698 A2**

(54) Title: METHOD AND APPARATUS FOR INFLUENCING CUSTOMER BUYING PATTERNS

(57) Abstract:

## METHOD AND APPARATUS FOR INFLUENCING CUSTOMER BUYING PATTERNS

The present invention relates to a computer based method and apparatus for supplying products to customers. The method and apparatus provides the customer with an easily accessible online advertising catalogue comprising a variety of products offered for sale and allows the customer to make a selection of products from the catalogue. The method and apparatus then influences the customer's subsequent buying pattern by providing incentives to promote the reordering of the initial order or the ordering of a selection that is substantially similar.

Contemporary methods for supplying customers with products primarily involve an offer to sell a particular product to a customer at a price determined by the seller. The customer then chooses whether or not to accept the offer. This method suffers from the problem that the seller cannot accurately forecast the type and amount of products required by a particular customer because the customer will usually purchase items as and when required from a number of various sellers on the basis of price comparison and accessibility.

In an attempt to overcome the problem methods that attempt to forecast the buying behaviour of customers using demographic information have been used. Alternatively suppliers/sellers have attempted to modify the buying behaviour of customers so that the buying behaviour of customers may be predicted. Such attempts at modification of the buying behaviour include special promotions upon the sale of particular products and providing loyalty cards wherein points are accrued when particular products are purchased wherein the points can then be subsequently exchanged for discounts or other benefits.

However there is a continuing need to further modify the buying behaviour of the

customer and the present invention provides a method that can enable an increase in the amounts of steady frequent volumes purchased by the customer and allows predicable and accurate forecasting of a range of products and the volume required by a particular customer over a given period of time. Furthermore the method and apparatus also provide increased long  
5 term loyalty and commitment to a single point of sale.

Accordingly the present invention provides a method for supplying products to customers which utilises a computer system wherein said computer system comprises a central controller which is accessible for interactive communication with users via a plurality of customer interfaces, said method comprising:

- 10 a) displaying from the central controller an advertising catalogue wherein said advertising catalogue comprises a list of different products
- b) inputting into the central controller via a customer interface a customer identifier and a first request to purchase a first selection of at least 2 products
- c) outputting from the central controller to the customer interface a consideration for the  
15 purchase of said first selection of products and storing the details of said first selection corresponding to respective customer identifier
- d) inputting into the central controller via a customer interface said customer identifier and a second request to purchase a second selection of products wherein the second selection comprises at least 2 products identical to those in the first selection and
- 20 e) outputting from the central controller to the customer interface a consideration more attractive to the customer for the purchase of said second selection of products.

Preferably the method comprises inputting into the central controller a plurality of subsequent requests e.g. a third, fourth or fifth request to purchase a selection of products wherein the selection comprises at least 2 products common to at least one of the previous  
25 selections and wherein the central controller outputs a consideration more attractive to the customer for the purchase of the present selection when compared to the consideration for the purchase of the previous selection comprising the common products.

The selection of products comprises at least 2 products but usually comprises at least 3-  
10 products e.g. 4-8. The selection will also comprise a request for a specific quantity of each  
30 product in terms of number, weight or volume and usually a delivery/logistics option for each of the products or for the total selection. Advantageously the selection may have a time limit

request for the delivery for each or all of the products within the selection.

In a preferred embodiment of the invention the consideration offered to the customer becomes increasingly attractive when the subsequent selection includes all of the products present in a previous selection. The similarity of the selection may be identified in terms of  
5 product type but may be further specified by number, volume or weight of product, delivery location(s) and/or time limits requested for those deliveries. Furthermore the consideration offered to the customer may become increasingly attractive as the number of similar selections are repeated and the consideration offered to the customer may further increase if the selections are made within a specific time period. Thus the consideration offered to the  
10 customer becomes most attractive when identical selections are made a number of times within a specific time period e.g. monthly, quarterly or annually.

Usually when the consideration for the purchase of a selection is outputted to the customer interface via the central controller details of delivery are also provided. The central controller usually generates an order and arranges the delivery of the products to the customer  
15 preferably by connection to a supplier interface.

The consideration for the purchase of the products may be a financial sum but may be the supply of goods or services. The consideration may be made more attractive to the customer by way of a financial discount such that the customer pays less for the same products upon a repeated selection that is substantially similar to a previous selection. Alternatively  
20 additional products or increased volumes may be supplied for the original consideration or the products may be supplied within a reduced time limit or points may be awarded wherein the points can then be subsequently exchanged for discounts, products or other benefits.

The consideration is usually a financial sum and this is usually supplied to the central controller via the customer interface by inputting a payment identifier e.g. details of a financial  
25 account or credit card details. These details are checked prior to the completion of the purchase by the central controller.

The products may be retail goods such as electrical goods e.g. household appliances, computers and software, home entertainment products and office equipment or may be retail goods such as clothing, books and magazines, CD and videos, toys and games, home  
30 furnishings or food and drink. The products may also be any other consumer items e.g. commercial vehicles such as vans, tractors, and lorries etc.

Preferably the products are industrial products such building materials e.g. timber, bricks and mortar, steel or scaffold, or machinery components or chemical products. Preferably the advertising catalogue comprises a list of different products obtainable from at least 2 different suppliers. The suppliers typically provide a range of products to the advertising catalogue that differ from those products in the advertising catalogue supplied by other suppliers but are preferably complementary.

In a preferred embodiment of the invention the products are chemical products and the advertising catalogue usually comprises the products from at least 2 chemical suppliers. The number of suppliers is most preferably at least 3-20 e.g. 5-10 and the suppliers usually provide the advertising catalogue with products of differing, preferably complementary, types.

Typically a solvent manufacturer may supply solvents such as ethyl acetate, ethanol, ethoxypropanol, butyl glycol ether, isopropanol, methoxypropanol, acetone, methyl ethyl ketone, butyl glycol acetate, isobutyl acetate, isopropyl acetate, toluene and n-butyl acetate and a resin manufacturer may typically supply products such as alkyd resins, coumarone resins, phenolic modified resin, polyamide resins, rosins and varnish.

Further examples of suppliers may be those in the additives business supplying products such as polyethylene wax, surfactants, plasticisers, driers and tannic acid or those in the pigment business supplying carbon black, iron blue pigments, organic pigment, synthetic dyes, titanium dioxide, ultramarine blue pigment and yellow basic dye.

The chemical products are usually supplied with an MSDS data sheet as required in the various jurisdictions of manufacture and/or supply and the central controller may also display technical information and health and safety information for each product.

The customers can order relatively small amounts of products or bulk quantities. The customer's selection is usually necessary to cater for a particular industry such as coatings, inks, adhesives, packaging and textiles. A typical selection may be blue pigment, ethyl acetate, phenolic modified resin, plasticiser, polyethylene wax and toluene or could include basic yellow dye, varnish, blue pigment, glycol ether, tannic acid and ethanol and is subsequently termed a 'bundle' which is unique to that particular customer and relates to his particular business requirements.

A customer may register with the central controller by providing credit details or details via which payment can be afforded. In addition information such HSE (health, safety

and environment) requirements may also be required for registration. The customer may also register various delivery locations. The customer is then provided with a customer identifier and preferably a payment identifier.

In an embodiment of the invention the central controller displays an advertising catalogue with a price list and preferably delivery/logistics options. The customer may then interact with the central controller via the customer interface by entering a customer identifier and preferably a payment identifier. The central controller recognises the customer identifier and consults the database wherein the customer profiles are stored. The central controller can then display the advertising catalogue and various selections that are similar to, preferably identical to those previous selections made by the same customer. The customer may also browse the details of his previous selections.

If this is not the customers initial interaction with the central controller then the prices displayed in the advertising catalogue or the prices for various products if purchased as a package or 'bundle' become unique to that customer because they are calculated with regard to the customers previous buying history. The customer can then select a list of products or reorder his previous selection. The customer can then confirm the selection and the central controller identifies the product availability and provides the customer with a quotation on price, availability, lead time and the delivery/logistics options.

The order for the selection is placed when the customer accepts a quotation and selects a delivery/logistics option. The acceptance is inputted into the central controller via the customer interface and the central controller checks the status of the customer's account or performs a credit check. The payment for the selection may be arranged either on acceptance or on delivery and may be made by debiting the customers account or accepting payment via a credit card account or generating an invoice. The selection is then stored in the customer profile database of the central controller along with the respective customer identifier. Preferably the central controller interacts with supplier interfaces by outputting instructions regarding the delivery/logistics requirements of the customer.

Preferably the method is conducted over the Internet and the World Wide Web. The WWW allows a server computer system to act as the central controller which can send Web pages of information carrying the advertising catalogue to the customer interfaces. Each customer interface can then display the Web pages and the Web pages are uniquely identifiable

by a Uniform Resource Leader (URL). To view the Web page the customer interface specifies the URL for that Web page in a request e.g. a Hyper Text Transfer Protocol (HTTP) request.

The present invention also provides apparatus comprising a central controller connected to a customer interface and wherein said central controller comprises

- 5 a) a first memory area for storing and displaying an advertising catalogue
- b) an input device for inputting a customer identifier
- c) a second memory area for storing customer identifiers and the respective customer selections
- d) software capable of calculating and displaying a consideration for the purchase of a  
10 selection of goods based on the number of products, the weight or volume of product and the similarity of previous selections made by the customer
- e) a customer interface comprising a device for inputting the customer identifier into the central controller and selecting products from the advertising catalogue.

The customer interface usually comprises a digital computer having memory, such as a  
15 hard disk, a display, such as a monitor, and an input device such as a keyboard, and a means for selecting products from the advertising catalogue.

The central controller is usually a computer system that stores information e.g. a server comprising a server engine and the central controller is usually accessible for interactive communication by the customer interface by on-line interactive communication via dedicated  
20 data networks such as those provided by a telephone company or satellite networks. Preferably the on line interactive communication occurs via an intranet or most preferably via the Internet and the World Wide Web (WWW).

The invention will now be described with reference to the accompanying drawing.

FIG 1 is a block diagram illustrating an embodiment of the present invention. This  
25 embodiment allows the selection of products over the Internet using the World Wide Web. The central controller is a server system (1) which includes a server engine (2), a customer identifier (3), various Web pages (4) and (12), a customer profile database (5), an advertising catalogue database (6) and a memory area (7) for the discount calculation software. The customer interface (8) comprises a digital computer having memory (9) a monitor (10), and a  
30 keyboard (11). The server system (1) and the customer interface (8) are in online interactive communication via the Internet.

The server engine (2) receives HTTP requests to access Web pages identified by URLs and provides Web pages (4) to the customer interface (8). The Web pages displayed can be accessed by the computer (9) and display on monitor (10) information from the advertising catalogue database (6). The Web pages (4) provide information such as a list of products that can be purchased, their respective prices, availability and delivery time.

The customer interface (8) can then input into the server system (1) a code which is recognised by the customer identifier (3). This customer identifier may include a payment identifier (not shown) that allows the server system (1) to charge the customer for any purchases. Upon receiving the customer identifier the server system (1) can then access the customer database (5), the advertising catalogue database (6) and the discount calculation software. The server system (1) can then calculate discounts for the purchase of a selection of goods from the advertising catalogue based on the number of products, the weight or volume of product and the similarity of previous selections made by the customer. The Web pages (4) are then replaced by Web pages (12) displaying the revised offers. The customer may then make a selection of products from the Web pages (12) and information regarding the selection is placed in the customer profile database (5). The server engine can then charge the customer by generating an invoice or debiting an account either upon acceptance by the customer or upon delivery of the selection.

20

25

30



## Claims

1. A method for supplying products to customers which utilises a computer system wherein said computer system comprises a central controller which is accessible for interactive communication with users via a plurality of customer interfaces, said method comprising:
- a) displaying from the central controller an advertising catalogue wherein said advertising catalogue comprises a list of different products
  - b) inputting into the central controller via a customer interface a customer identifier and a first request to purchase a first selection of at least 2 products
  - c) outputting from the central controller to the customer interface a consideration for the purchase of said first selection of products and storing the details of said first selection corresponding to respective customer identifier
  - d) inputting into the central controller via a customer interface said customer identifier and a second request to purchase a second selection of products wherein the second selection comprises at least 2 products identical to those in the first selection and
  - e) outputting from the central controller to the customer interface a consideration more attractive to the customer for the purchase of said second selection of products.
2. A method according to claim 1 comprising (f) inputting into the central controller a third request to purchase a selection of products wherein the selection comprises at least 2 products common to at least one of the previous selections and (g) outputting from the central controller a consideration more attractive to the customer for the purchase of the present selection when compared to the consideration for the purchase of the previous selection comprising the common products.

3. A method according to anyone of the preceding claims wherein the selection of products comprises at least 3 products identical to those in a previous selection.
4. A method according to anyone of the preceding claims wherein the consideration offered to the customer becomes increasingly attractive as the subsequent selection approaches  
5 the exact selection of that made previously.
5. A method according to anyone of the preceding claims wherein the customer makes numerous requests and the consideration offered to the customer becomes increasingly attractive as the number of similar selections are repeated.
6. A method according to anyone of the preceding claims wherein the subsequent  
10 selection includes all of the products present in a previous selection.
7. A method according to anyone of the preceding claims wherein all the selections are identical.
8. A method according to anyone of the preceding claims wherein the central controller generates an order and arranges the delivery of the products to the customer.
- 15 9. A method according to anyone of the preceding claims wherein the consideration for the purchase of the products is financial sum and is made more attractive to the customer by way of a financial discount.
10. A method according to anyone of the preceding claims wherein the advertising catalogue comprises a list of different products obtainable from at least 2 different suppliers.
- 20 11. A method according to anyone of the preceding claims wherein the products are chemical products.
12. A method according to claim 10 wherein the advertising catalogue comprises a list of different chemical products obtainable from at least 2 different chemical suppliers.
13. A method according to anyone of the preceding claims wherein a payment identifier  
25 is inputted into the controller system via the customer interface.
14. A method according to anyone of the previous claims wherein the central controller is a server and the customer interface is a computer and the interactive communication is conducted over the Internet via the World Wide Web.
15. Apparatus comprising a central controller connected to a customer interface wherein  
30 said central controller comprises
  - a) a first memory area for storing and displaying an advertising catalogue

- b) an input device for inputting a customer identifier
- c) a second memory area for storing customer identifiers and the respective customer selections
- d) software capable of calculating and displaying a consideration for the purchase of a selection of goods based on the number of products, the weight or volume of product and the similarity of previous selections made by the customer
- e) a customer interface comprising a device for inputting the customer identifier into the central controller and selecting products from the advertising catalogue.

16. Apparatus according to claim 14 wherein the customer interface is digital computer a hard disk, a monitor, and a keyboard.

17. Apparatus according to claim 14 and claim 15 wherein the central controller is a server comprising a server engine.

18. Apparatus according to anyone of the preceding claims 14-16 wherein the central controller is accessible for interactive communication by the customer interface by on-line interactive communication via the Internet and the World Wide Web (WWW).

20

25

30

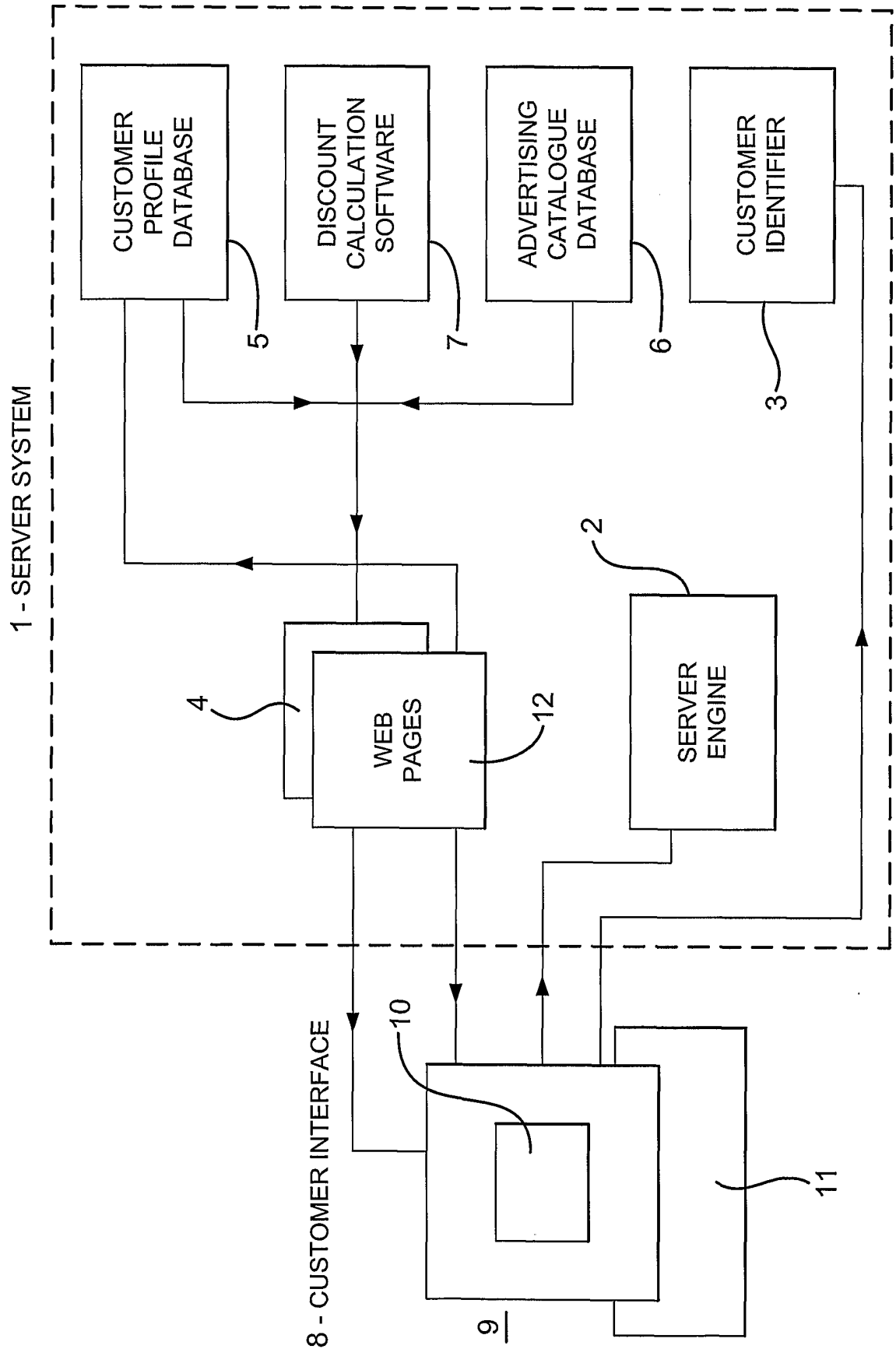

PATENT COOPERATION TREATY  
**PCT**

## DECLARATION OF NON-ESTABLISHMENT OF INTERNATIONAL SEARCH REPORT

(PCT Article 17(2)(a), Rules 13ter.1(c) and Rule 39)

Applicant's or agent's file reference 9323	IMPORTANT DECLARATION	Date of mailing( <i>day/month/year</i> ) 02/07/2001
International application No. PCT/GB 01/ 01349	International filing date( <i>day/month/year</i> ) 27/03/2001	(Earliest) Priority date( <i>day/month/year</i> ) 27/03/2000
International Patent Classification (IPC) or both national classification and IPC		G06F17/60
Applicant BP AMOCO PLC et al.		

This International Searching Authority hereby declares, according to Article 17(2)(a), that **no international search report will be established** on the international application for the reasons indicated below

1.  The subject matter of the international application relates to:
- a.  scientific theories.
  - b.  mathematical theories
  - c.  plant varieties.
  - d.  animal varieties.
  - e.  essentially biological processes for the production of plants and animals, other than microbiological processes and the products of such processes.
  - f.  schemes, rules or methods of doing business.
  - g.  schemes, rules or methods of performing purely mental acts.
  - h.  schemes, rules or methods of playing games.
  - i.  methods for treatment of the human body by surgery or therapy.
  - j.  methods for treatment of the animal body by surgery or therapy.
  - k.  diagnostic methods practised on the human or animal body.
  - l.  mere presentations of information.
  - m.  computer programs for which this International Searching Authority is not equipped to search prior art.
2.  The failure of the following parts of the international application to comply with prescribed requirements prevents a meaningful search from being carried out:
- the description       the claims       the drawings
3.  The failure of the nucleotide and/or amino acid sequence listing to comply with the standard provided for in Annex C of the Administrative Instructions prevents a meaningful search from being carried out:
- the written form has not been furnished or does not comply with the standard.
- the computer readable form has not been furnished or does not comply with the standard.
4. Further comments:

Name and mailing address of the International Searching Authority  European Patent Office, P.B. 5818 Patentlaan 2 NL-2280 HV Rijswijk Tel. (+31-70) 340-2040, Tx. 31 651 epo nl, Fax: (+31-70) 340-3016	Authorized officer Mar'a Rodr'guez N'voa
--	---

FURTHER INFORMATION CONTINUED FROM PCT/ISA/ 203

The subject-matter claimed in claims 1-14 falls under the provisions of Article 17(2)(a)(i) and Rule 39.1(iii), PCT, such subject-matter relating to a method of doing business.

Claims 15-18 relate to a conventional apparatus for performing the business method of claims 1-14. Although these claims do not literally belong to the method category, they essentially claim protection for the same commercial effect as the method claims. The International Searching Authority considers that searching this subject-matter would serve no useful purpose. It is not at present apparent how the subject-matter of the present claims may be considered defensible in any subsequent examination phase in front of the EPO as International Preliminary Examining Authority with regard to the provisions of Article 33(1) PCT (novelty, inventive step); see also Guidelines B-VII, 1-6).

The applicant's attention is drawn to the fact that claims relating to inventions in respect of which no international search report has been established need not be the subject of an international preliminary examination (Rule 66.1(e) PCT). The applicant is advised that the EPO policy when acting as an International Preliminary Examining Authority is normally not to carry out a preliminary examination on matter which has not been searched. This is the case irrespective of whether or not the claims are amended following receipt of the search report or during any Chapter II procedure. If the application proceeds into the regional phase before the EPO, the applicant is reminded that a search may be carried out during examination before the EPO (see EPO Guideline C-VI, 8.5), should the problems which led to the Article 17(2) declaration be overcome.