

G. H. PIERCE.  
Rock-Drilling Machines.

No. 133,478.

Patented Nov. 26, 1872.

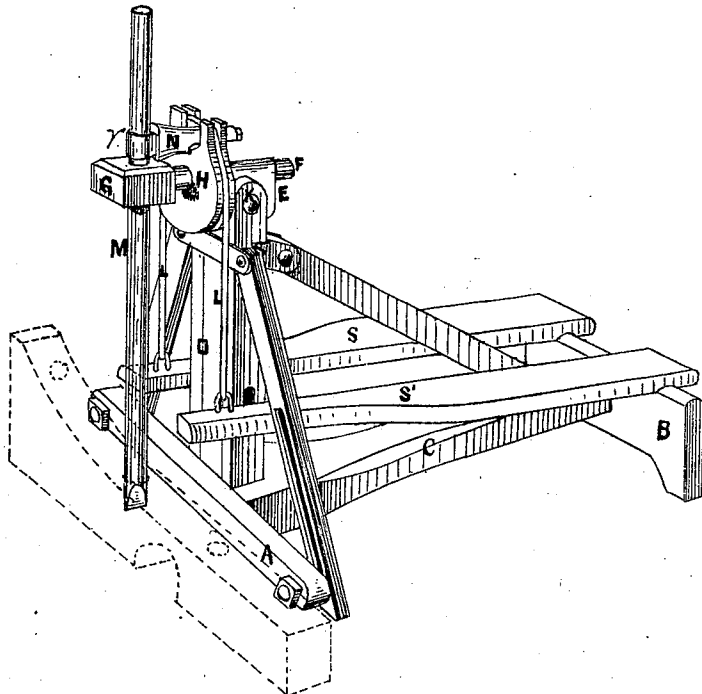

Fig. 1

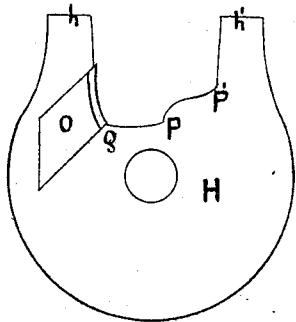

Fig. 2

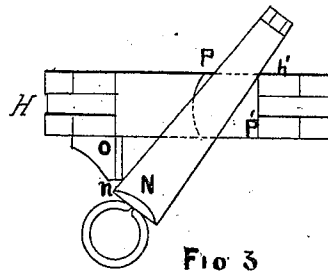

Fig. 3

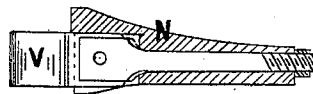

Fig. 4

WITNESSES.

*Frank G. Parker*  
*H. Lloyd*

INVENTOR

*Geo. H. Pierce*  
*per William Edson atty*

# UNITED STATES PATENT OFFICE.

GEORGE H. PIERCE, OF RICHMOND, CANADA.

## IMPROVEMENT IN ROCK-DRILLING MACHINES.

Specification forming part of Letters Patent No. 133,478, dated November 26, 1872.

*To all whom it may concern:*

Be it known that I, GEORGE H. PIERCE, of Richmond, Province of Quebec, Dominion of Canada, have invented certain new and useful Improvements in Rock-Drills, of which the following is a specification:

### *The Nature and Object of the Invention.*

The nature of my invention consists in combining with a rock-drill a clutch-lever operated by a rocking shield which is actuated by treadles. The clutch-lever performs the double function of lifting and turning the drill. An adjustable arm attached to the frame of the machine serves to hold the drill in any desired position. The object of the invention is to furnish a drill that can be readily operated by one man.

### *Description of the Accompanying Drawing.*

Figure 1 is a perspective view, showing the whole invention, and, in dotted lines, a piece of stone to be drilled. Fig. 2 is an elevation, showing the shield or operating-cam. Fig. 3 shows the same in plan, and with it the clutch-lever. Fig. 4 is a horizontal section of the clutch-lever.

### *General Description.*

Let A B C D represent the general frame of my machine, to which the other parts are attached. To the standard D of the machine a rocking saddle-block, E, is attached, being pivoted to D by the pin K. F G is a supporting-pin passing through the upper part of the saddle-block E, and so made as to be free to turn in the block; and, as the block E turns upon K, it will be seen that F G may be adjusted to any desired position. M represents the drill passing through the end of the supporting-pin F G. This device holds the drill at any desired angle, and allows it to move freely in the direction of its length and to be revolved. The above device for holding the drill in position also serves for holding and furnishing a journal for the shield H. This shield H has a strap, rope, or chain, L, passing over it, as shown in Fig. 1, the ends of the strap L being attached to the ends of the treadles S S', so that, as these treadles are alternately moved by the feet of the operator, an oscillating motion is imparted to the shield H. The clutch-lever N is constructed as shown in Figs. 3 and 4, the body N being of any

suitable rigid material, while the part V, which surrounds the drill M, is made of some suitable elastic material, which may serve as a friction-band for claspings the drill. Whenever the said lever is bent so as to bring one of its shoulders, n, Fig. 3, to exert a compressing force on the strap V, then the strap will grasp the drill and the continued motion of the lever will cause the drill to turn; and, if the lever is raised, then the drill will also ascend. Motion is imparted to this lever by the shield H, Figs. 1, 2, and 3. If this shield is thrown over by depressing the treadle S' the lever N will be brought into the position represented in Fig. 3—that is, it will rest upon the higher part P and P' of the shield, Figs. 2 and 3, and against the horn h'. Now, if the shield be thrown in the other direction by the treadle S the point n, Fig. 3, will gripe the strap V between it and the drill M. This will cause sufficient strain on the strap to hold the drill. Continued motion of the shield will cause the drill to be lifted, as the part P P' of the shield acts as a cam to lift the lever N, and, consequently, the drill M. This lifting process continues until the shield has assumed a vertical position; then the lever will drop into the lower part P Q, Fig. 2. After the drill has dropped the treadle S' is again depressed, which will return the clutch-lever N to the position represented in Fig. 3. In the return motion last described of the lever N the boss or projection O, Figs. 2 and 3, comes in contact with the lever N at a point near its connection with the drill, so that no leverage is produced to effect a strain on the strap V, so that, in the backward motion of the lever N, the strap V slips freely around the drill M.

I claim as my invention—

1. In a rock-drilling machine, the combination of the shield H and clutch-lever N, operating together in the manner substantially as described to actuate the drill M.

2. The combination of the saddle E, the supporting-pin F G, and drill M, substantially as described, and for the purpose set forth.

3. The combination of the treadles S S', strap L, and shield H, constructed substantially as described, and for the purpose set forth.

GEORGE H. PIERCE.

Witnesses:

FRANK G. PARKER,  
FRANK H. NUTTER.