



(22) Date de dépôt/Filing Date: 2005/04/12

(41) Mise à la disp. pub./Open to Public Insp.: 2006/10/12

(51) Cl.Int./Int.Cl. G21B 1/00 (2006.01)

(71) Demandeur/Applicant:
LAMONT, JOHN S., CA

(72) Inventeur/Inventor:
LAMONT, JOHN S., CA

(74) Agent: BATTISON WILLIAMS DUPUIS

(54) Titre : CENTRALE D'ENERGIE PAR FUSION INERTIELLE
(54) Title: INERTIAL FUSION ENERGY POWER STATION

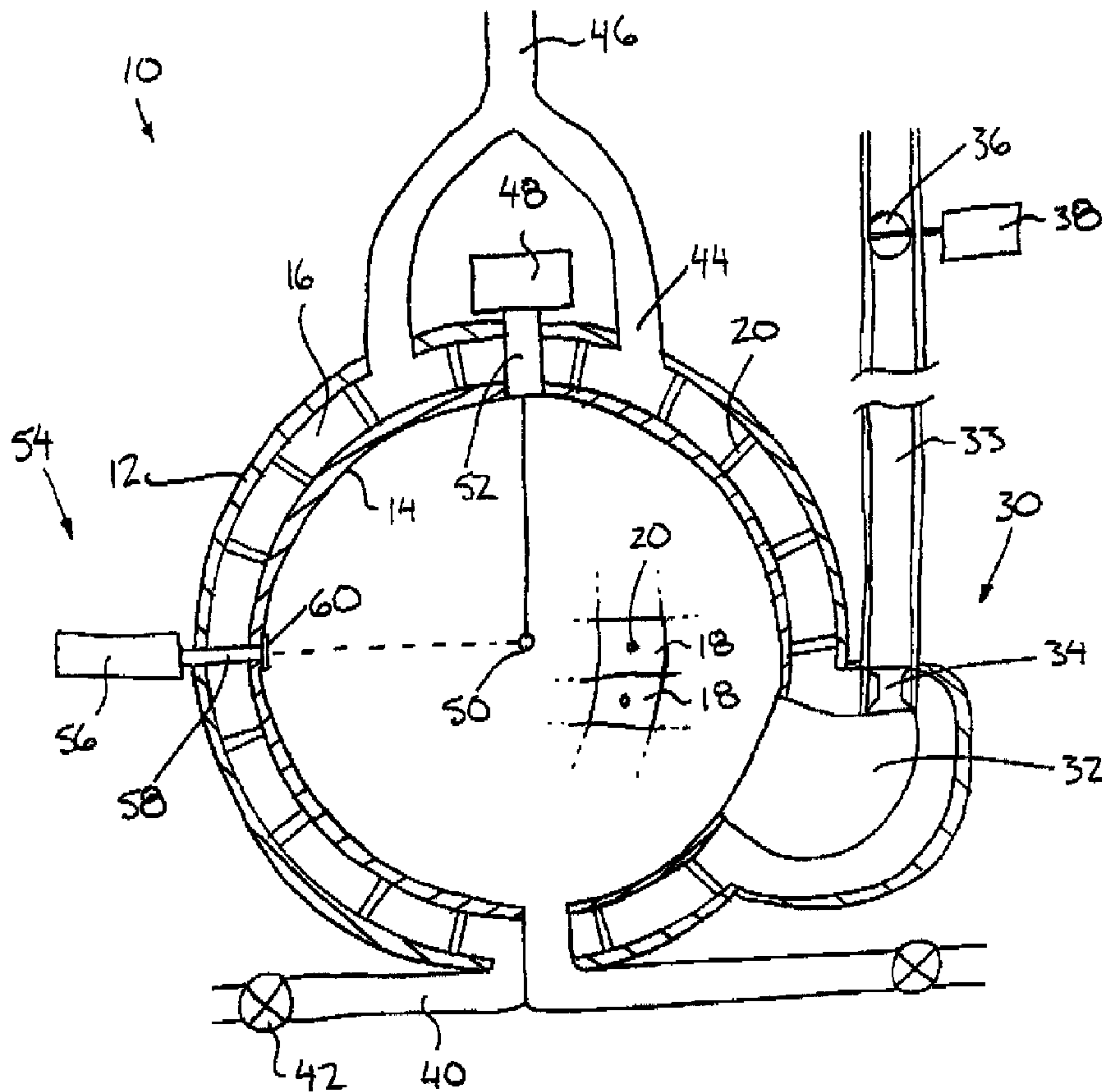

(57) Abrégé/Abstract:

An inertial fusion reactor device comprises an outer containment chamber and an inner containment chamber supported within the outer containment chamber to define a space between respective walls of the inner and outer containment chambers. Water is

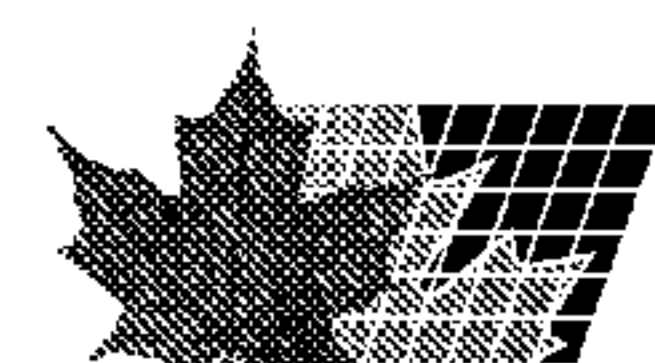

(57) **Abrégé(suite)/Abstract(continued):**

contained within the space for generating steam which feeds turbine generators. Fuel for a fusion reaction is suspended within the centre of the inner containment chamber by a suitable mechanism. The reaction is initiated by focussing a plurality of laser beams on the fuel. The structure permits the water to be used both for producing usable steam and for absorbing blast impact due to its incompressible nature.

ABSTRACT

An inertial fusion reactor device comprises an outer containment chamber and an inner containment chamber supported within the outer containment chamber to define a space between respective walls of the inner and outer containment chambers. Water is contained within the space for generating steam which feeds turbine generators. Fuel for a fusion reaction is suspended within the centre of the inner containment chamber by a suitable mechanism. The reaction is initiated by focussing a plurality of laser beams on the fuel. The structure permits the water to be used both for producing usable steam and for absorbing blast impact due to its incompressible nature.

CLAIMS:

1. An inertial fusion reactor device comprising:
 - an outer containment chamber;
 - an inner containment chamber supported within the outer containment
 - 5 chamber to define a space between respective walls of the inner and outer containment chambers;
 - feed means for selectively introducing a liquid into the space between the walls;
 - collecting means for collecting gas generated within the space between
 - 10 the walls;
 - target placement means for placing a target fuel within the inner containment chamber; and
 - driver means for compressing and heating the target fuel to initiate a fusion reaction.
- 15 2. The device according to Claim 1 wherein there is provided a shock absorption system coupled in communication with an interior of the inner containment chamber.
3. The device according to Claim 2 wherein the shock absorption system comprises a moveable column of fluid which is raised when pressure within
- 20 the inner containment chamber elevates.
4. The device according to Claim 3 wherein there is provided a valve in communication with the column of fluid for selectively preventing movement of fluid within the column.
5. The device according to Claim 3 wherein there is provided an
- 25 inlet chamber defining a volume external from the interior volume of the inner

chamber in communication between the interior of the inner containment chamber and the column of fluid.

6. The device according to Claim 1 wherein both the inner and outer containment chambers are spherical and wherein the chambers are concentric with
5 one another.

7. The device according to Claim 1 wherein exterior of the outer containment chamber is insulated.

8. The device according to Claim 1 wherein an interior surface of the inner containment chamber includes a liner of wear resistant material.

9. The device according to Claim 1 wherein the inner containment chamber is formed of a plurality of plates abutted with one another in an overlapping
10 configuration.

10. The device according to Claim 9 wherein each plate is supported by a respective post spanning the space between the inner and outer containment
15 chambers.

11. The device according to Claim 1 wherein there is provided a plurality of channels spanning between the inner and outer chambers for receiving driver beams of the drive means therethrough.

12. The device according to Claim 11 wherein each channel of the
20 driver means includes a cover member for selectively enclosing the channel.

13. The device according to Claim 1 wherein there is provided vacuum means in communication with the interior of the inner containment chamber.

14. The device according to Claim 13 wherein the vacuum means comprises a fluid port for selectively adding and removing fluid from the interior of the
25 inner containment chamber.

15. The device according to Claim 1 wherein the target placement means comprises a mechanism for suspending the target fuel at the center of the inner containment chamber.

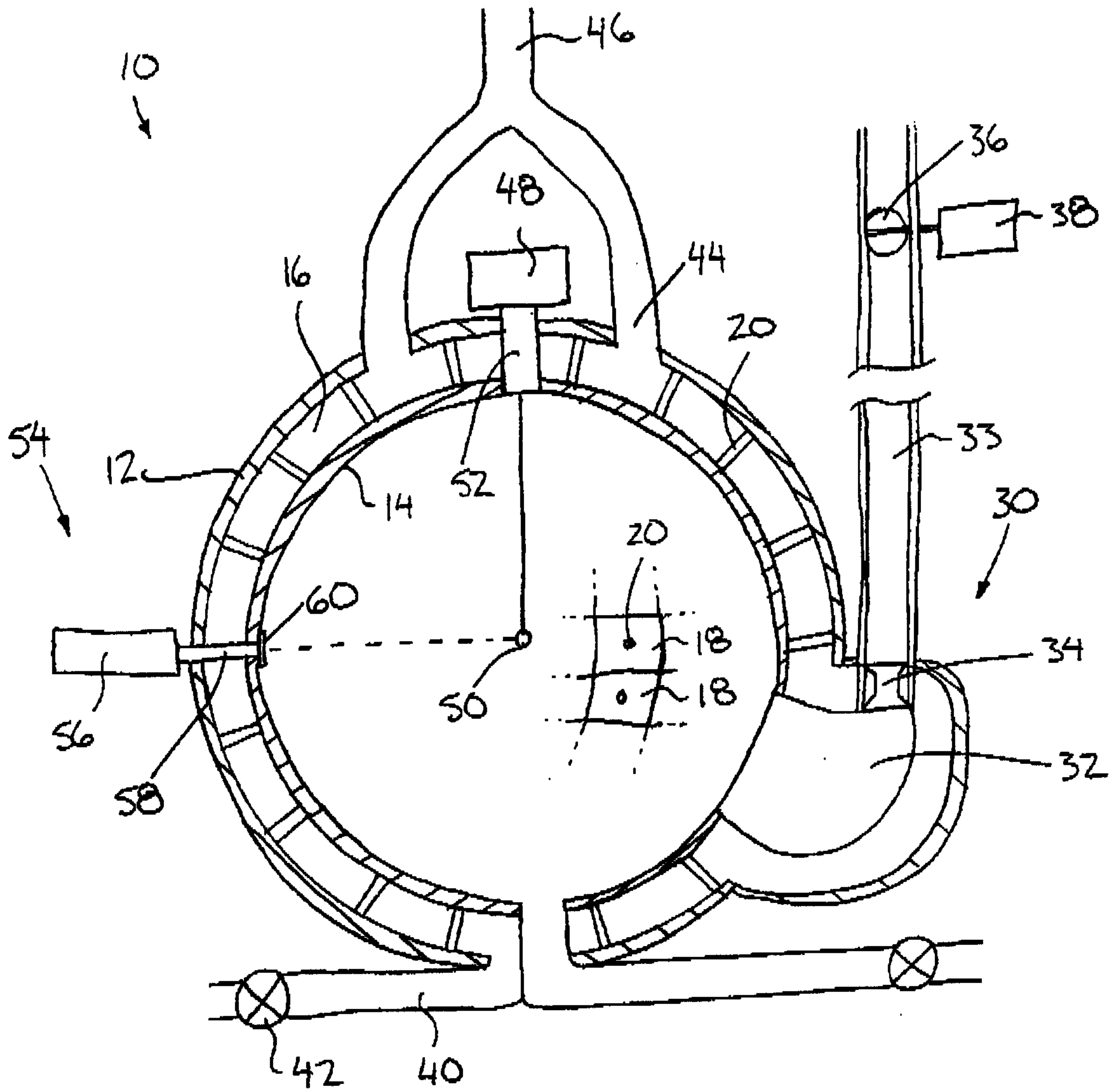

FIG. 1

INVENTOR:

John S. Lamont

PER:

ADE & COMPANY

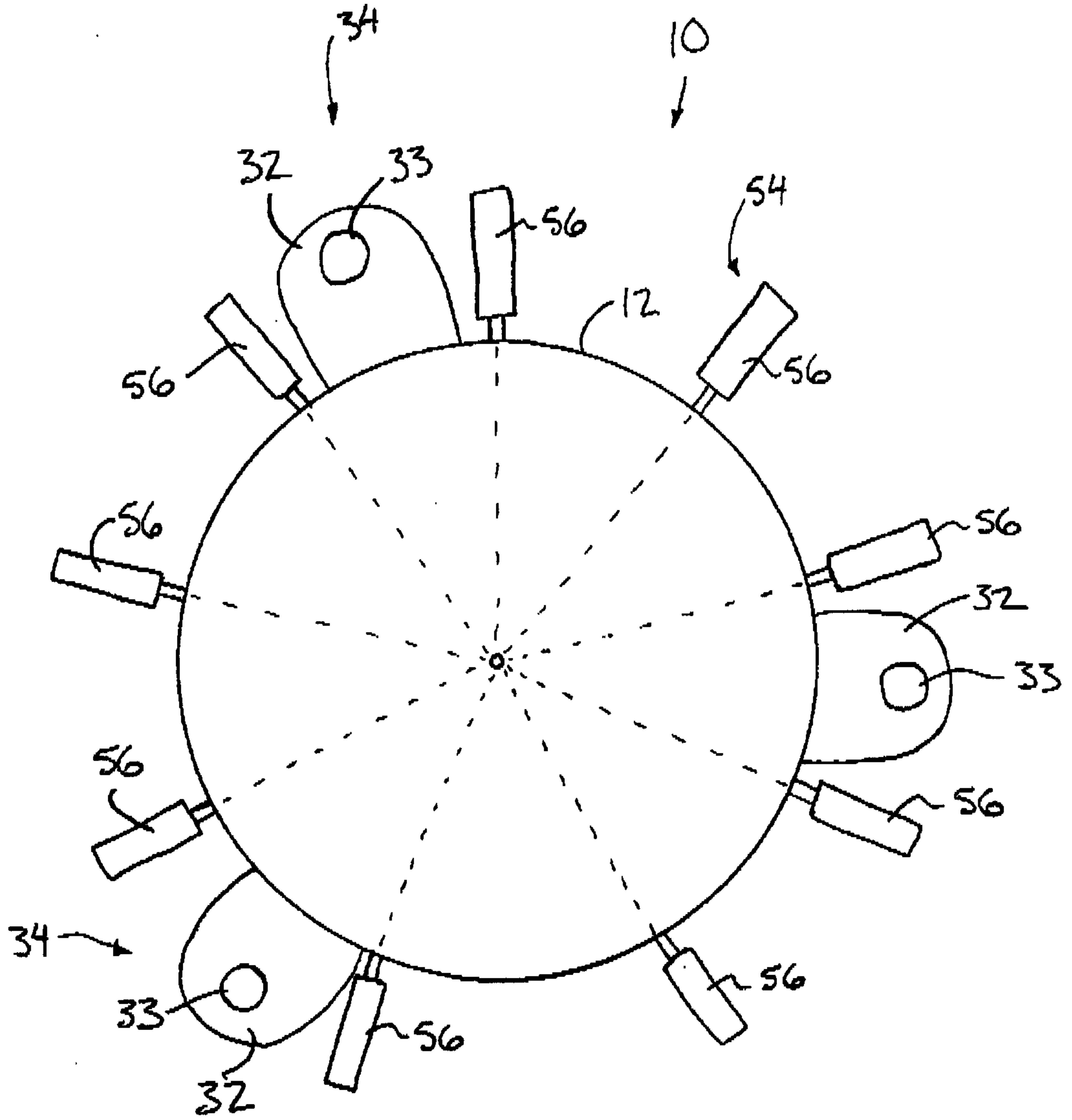

FIG. 2

INVENTOR:

John S. Lamont

PER:

ADE & COMPANY

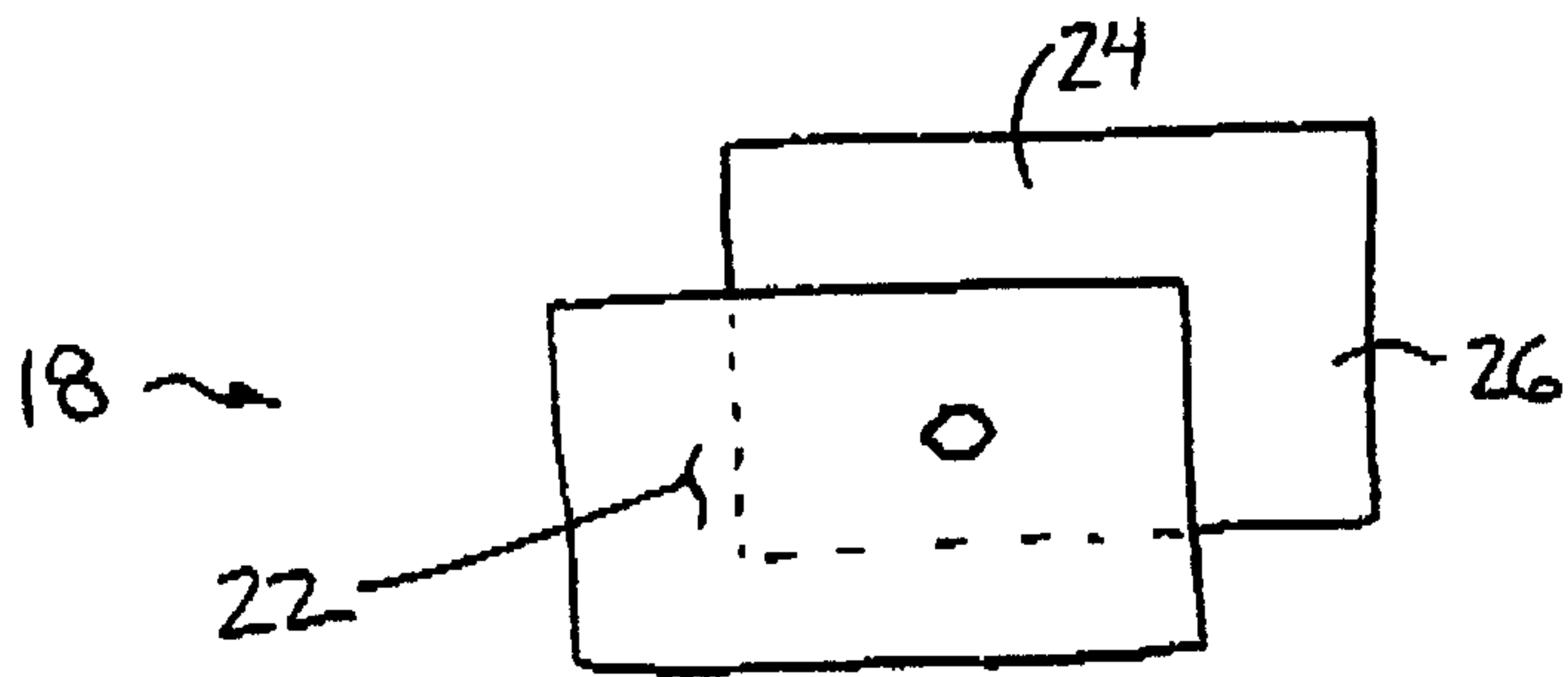
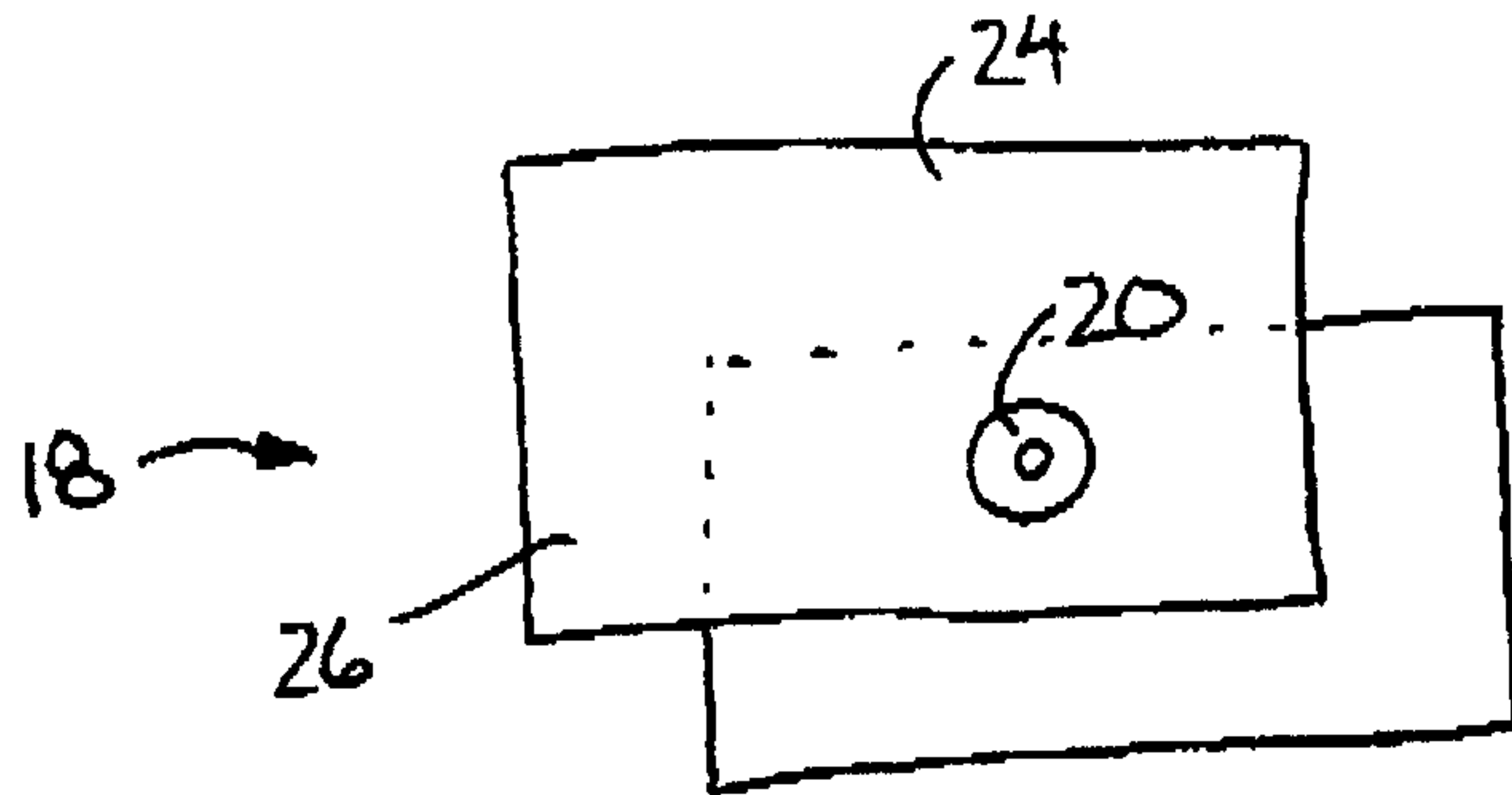
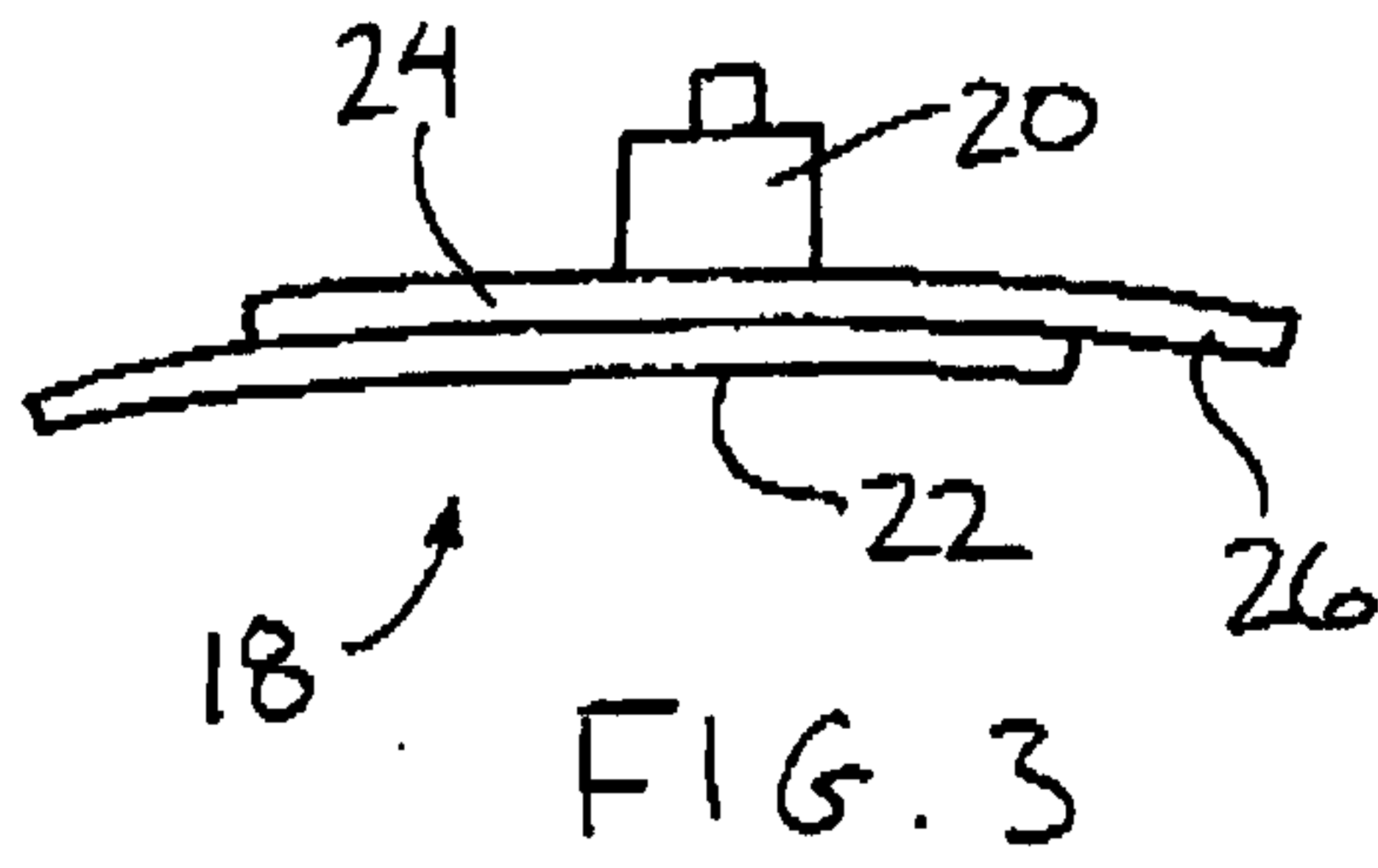

INVENTOR:

John S. Lamont

PER:

ADE & COMPANY

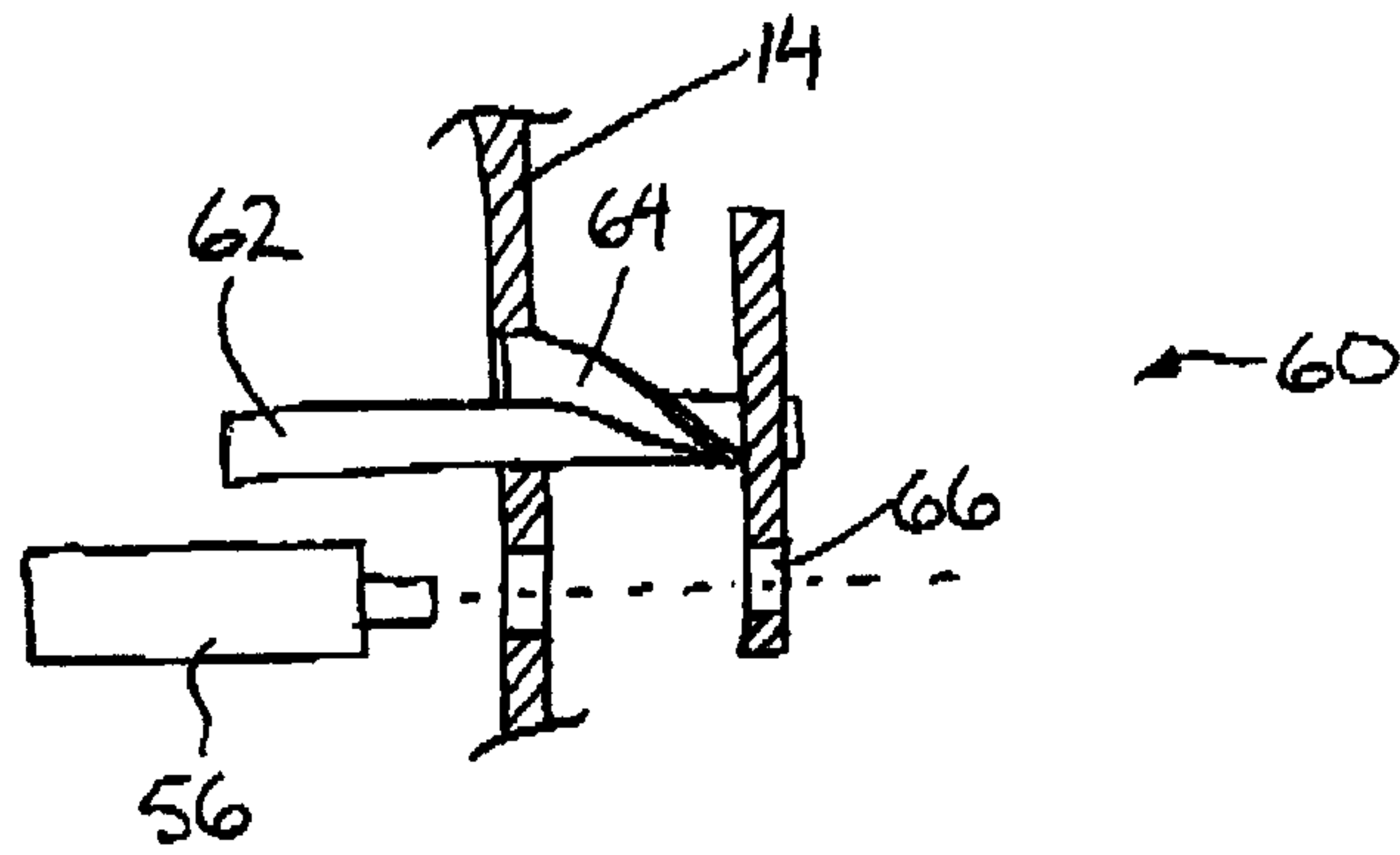

FIG. 6

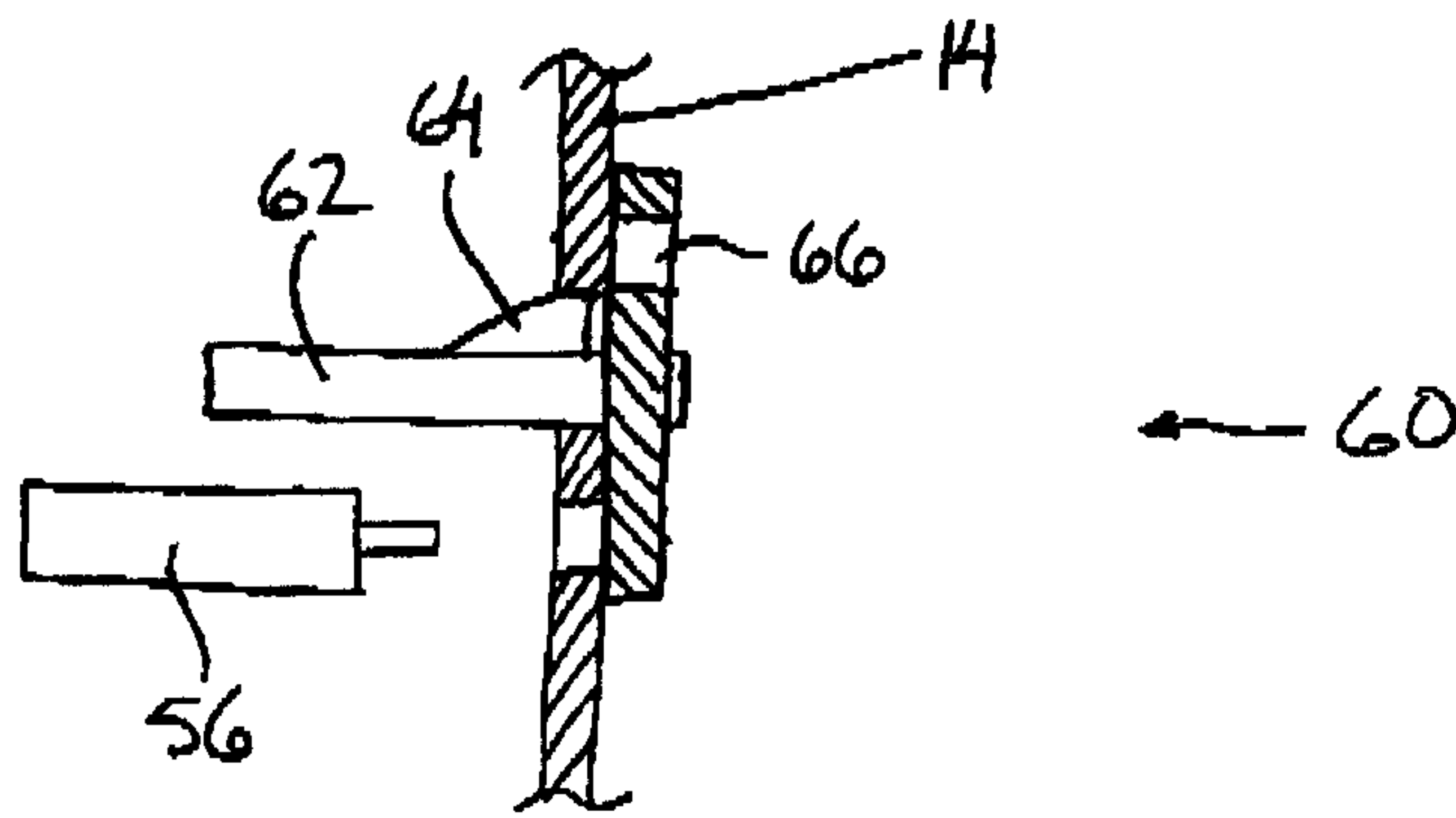

FIG. 7

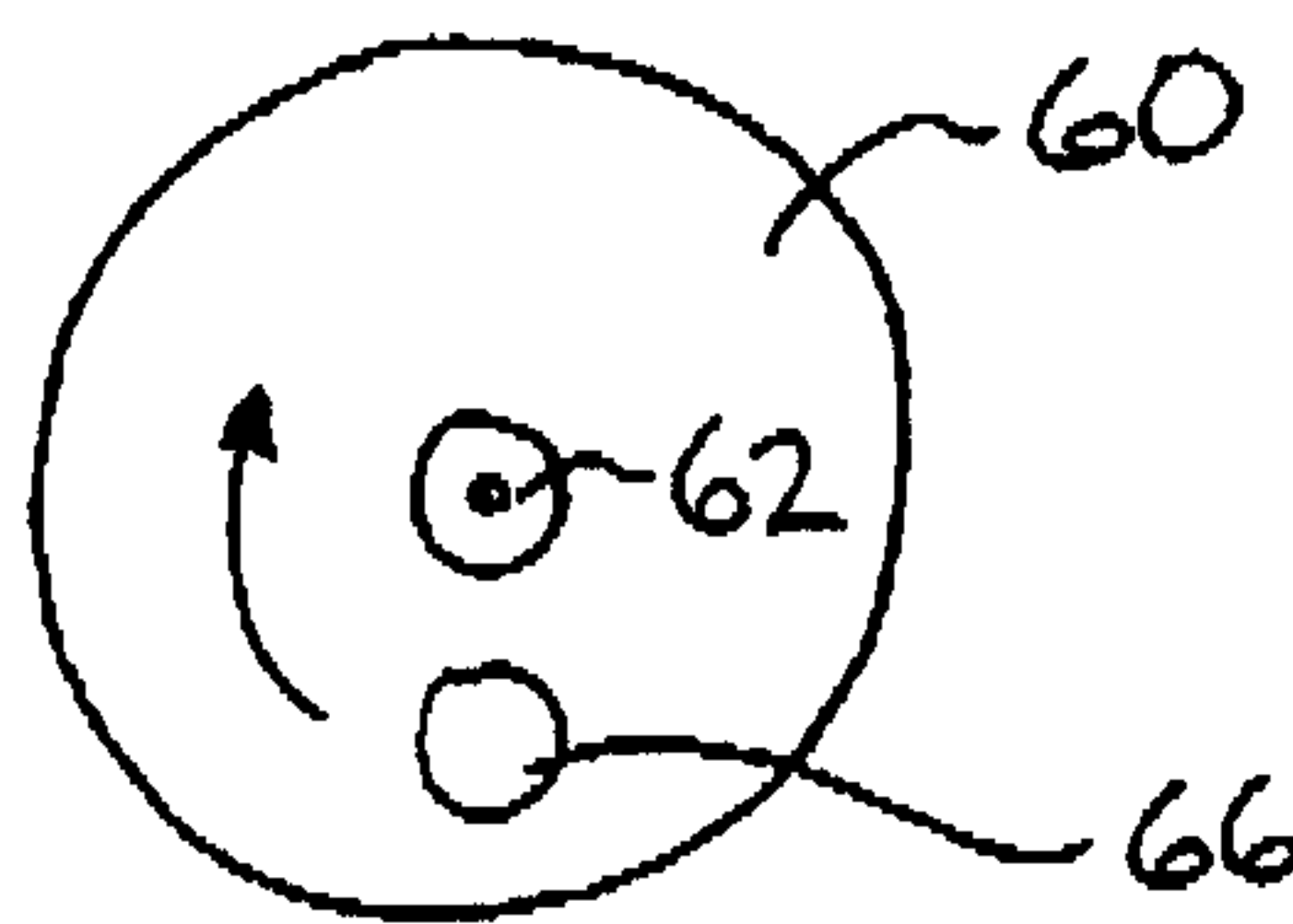

FIG. 8

INVENTOR:

John S. Lamont

PER:

ADE & COMPANY

