



US 20210195976A1

(19) **United States**

(12) **Patent Application Publication**  
**Lotti**

(10) **Pub. No.: US 2021/0195976 A1**

(43) **Pub. Date: Jul. 1, 2021**

(54) **SOCKS, APPLICATORS FOR LASH EXTENSIONS, AND METHODS OF MANUFACTURE AND USE THEREOF**

**Publication Classification**

(51) **Int. Cl.**  
*A41G 5/00* (2006.01)  
*A41G 5/02* (2006.01)  
(52) **U.S. Cl.**  
CPC ..... *A41G 5/0086* (2013.01); *A41G 5/02* (2013.01)

(71) Applicant: **Lashify, Inc.**, Los Angeles, CA (US)

(72) Inventor: **Sahara Lotti**, Los Angeles, CA (US)

(21) Appl. No.: **16/644,615**

(22) PCT Filed: **Jan. 14, 2020**

(57) **ABSTRACT**

(86) PCT No.: **PCT/US2020/013554**

§ 371 (c)(1),

(2) Date: **Mar. 5, 2020**

**Related U.S. Application Data**

(60) Provisional application No. 62/792,048, filed on Jan. 14, 2019.

An applicator with arms having tip portions. Socks may be configured to be mounted to the tip portions. The tip portions can have a sock mounted thereon. The tip portion may be externally coated with a non-stick coating, thereby resisting adhesive used to apply lash extensions to natural eyelashes. The tip portion may be used to apply the lash extensions to a natural eyelashes of a user.

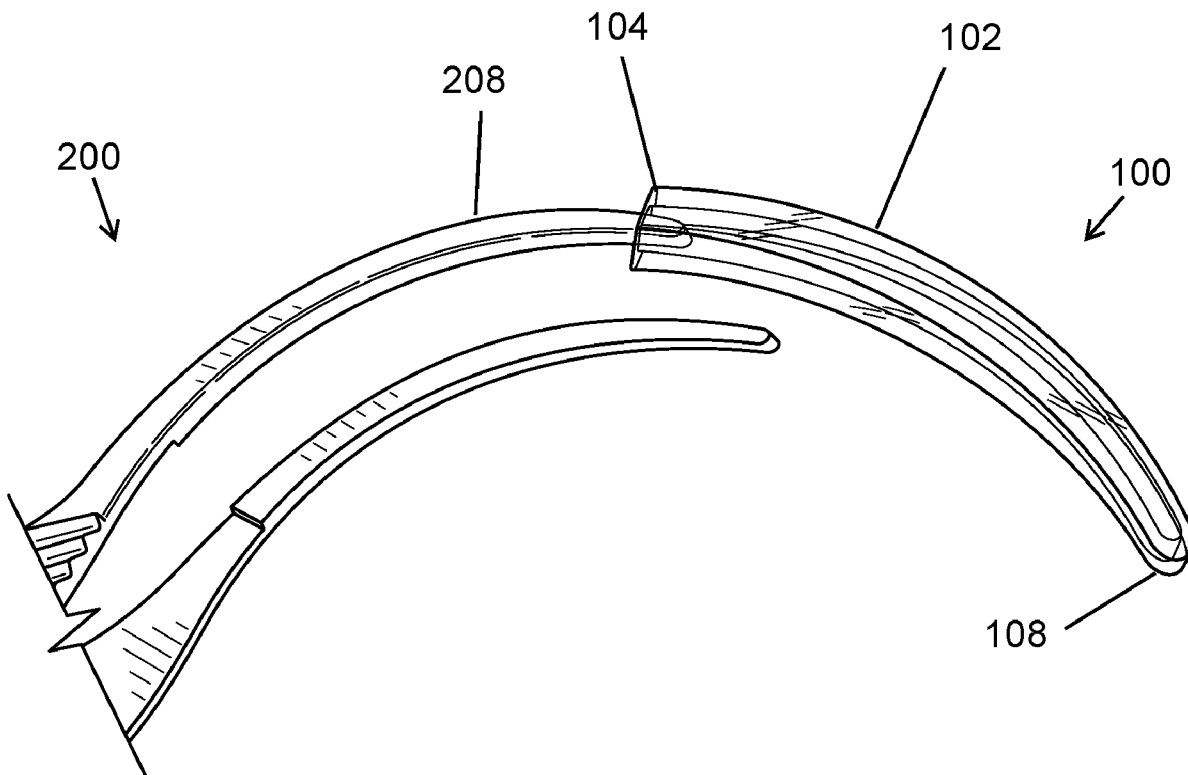

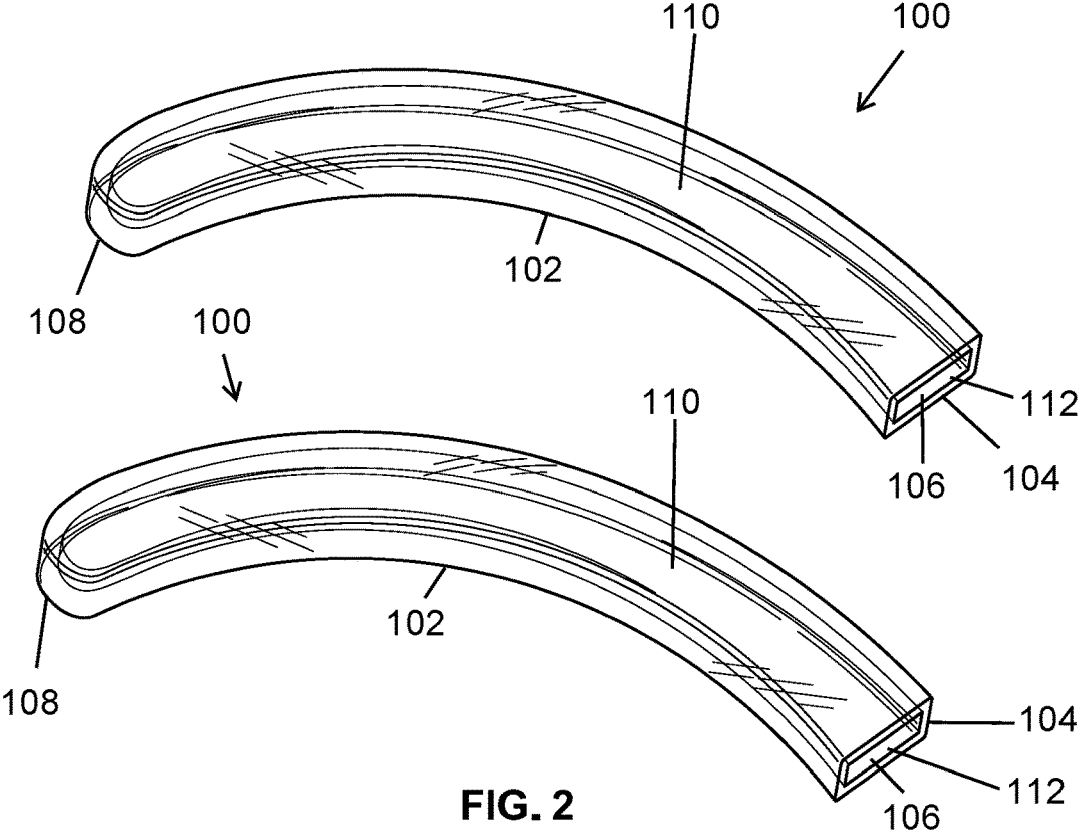
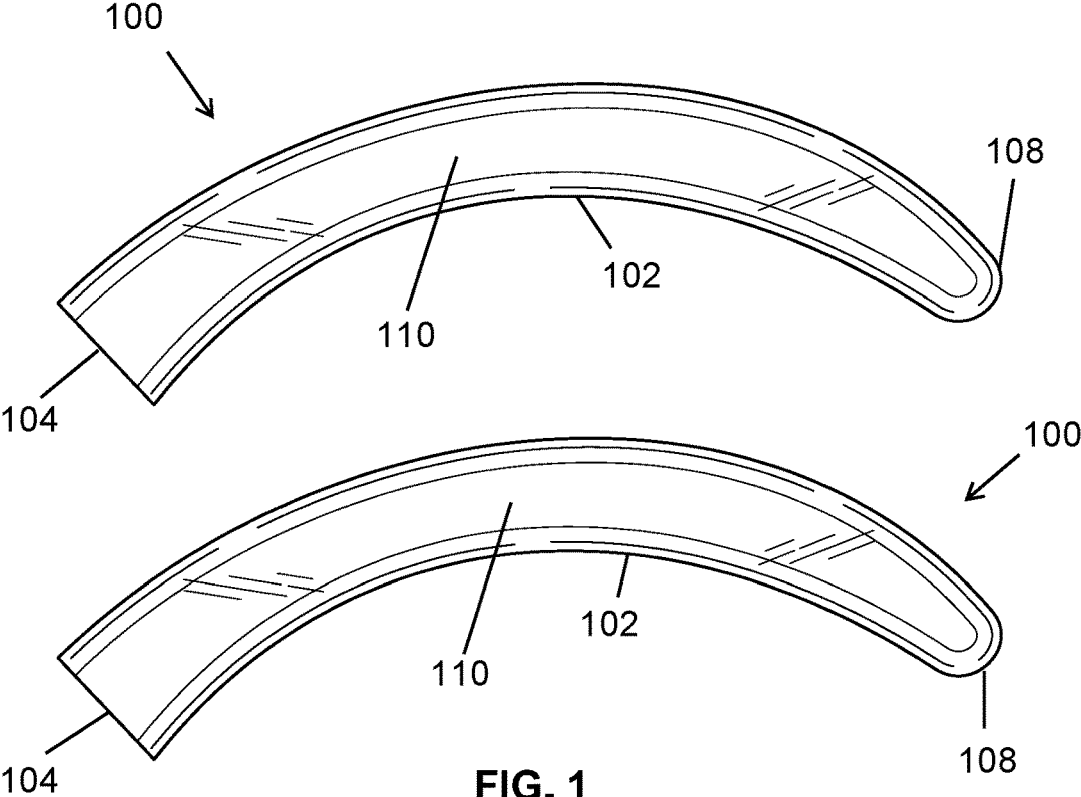

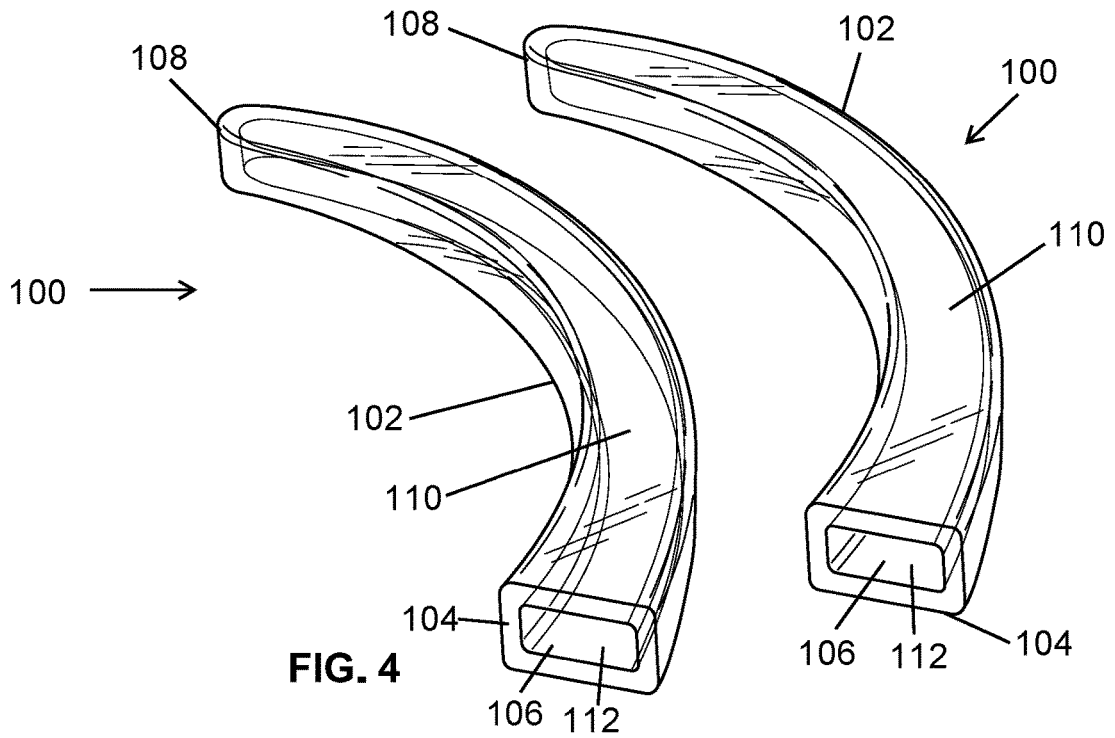
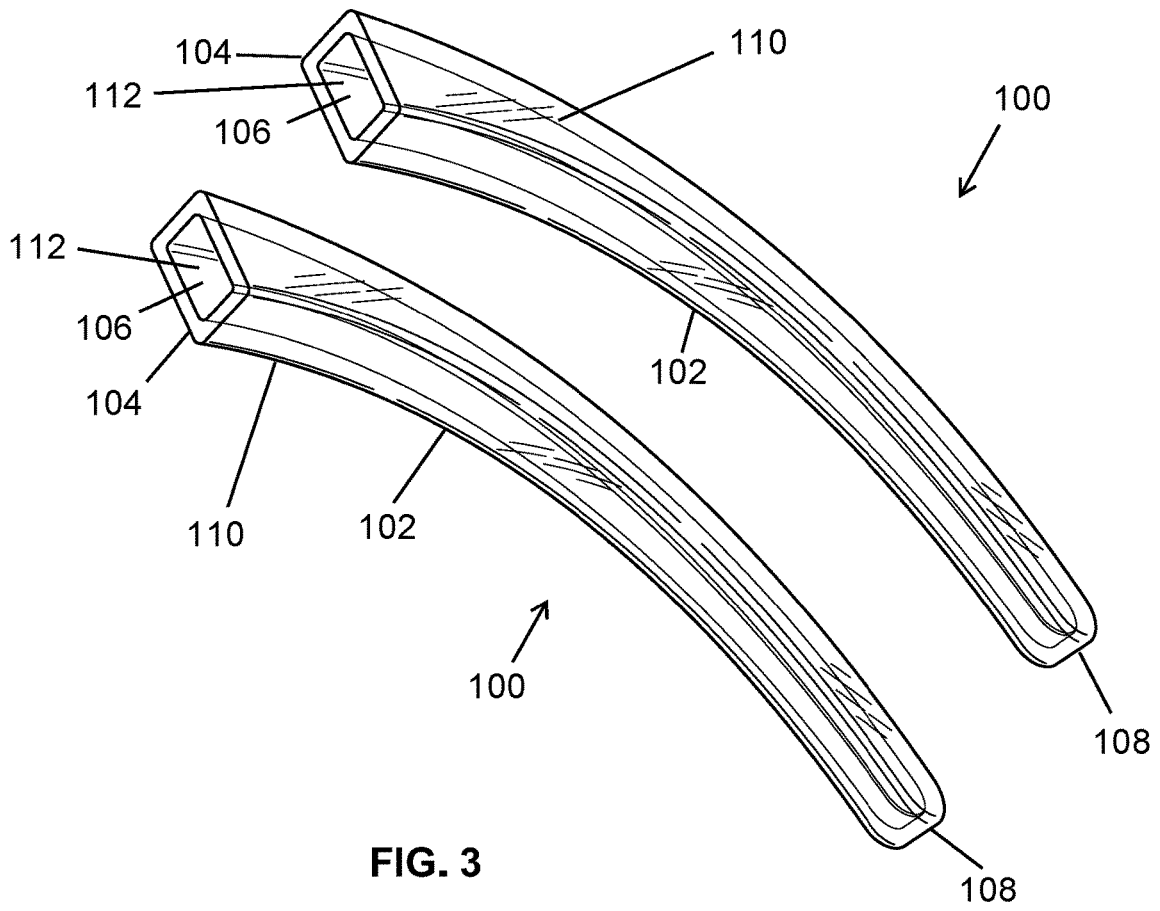

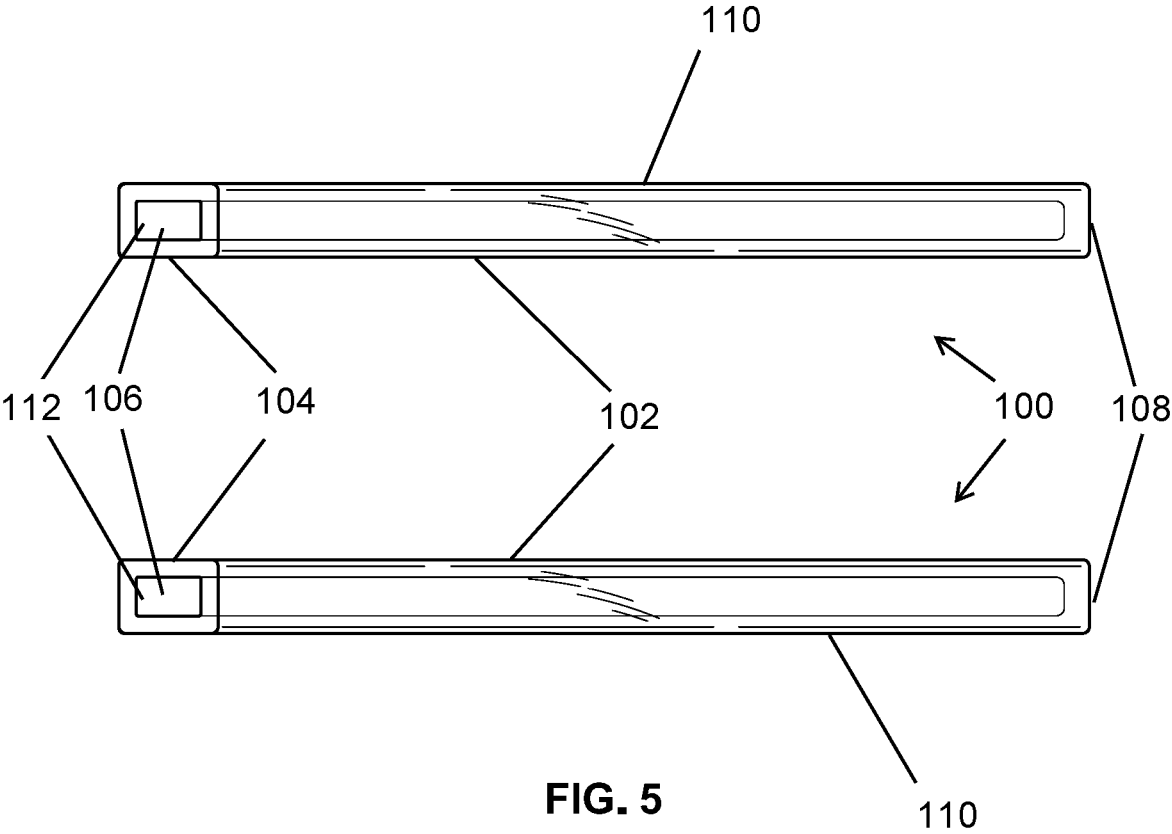

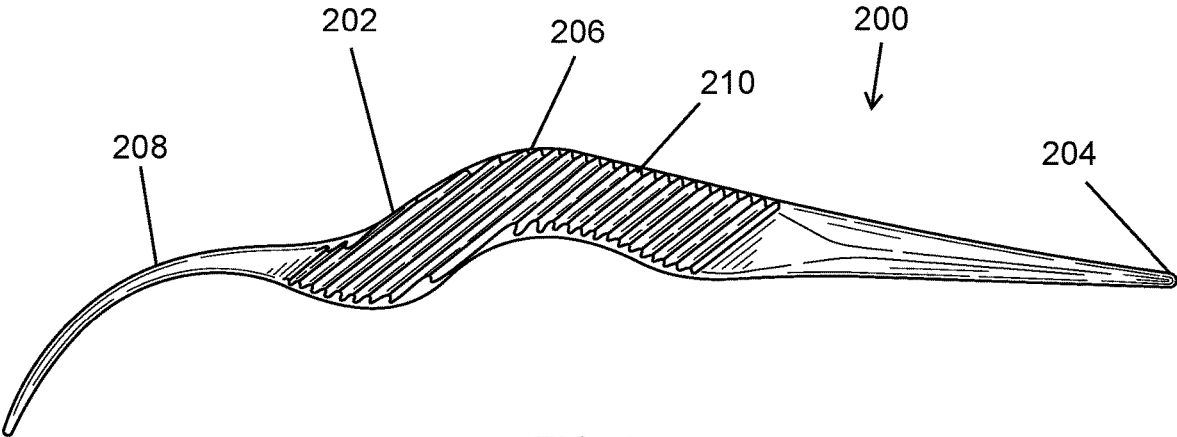

FIG. 6

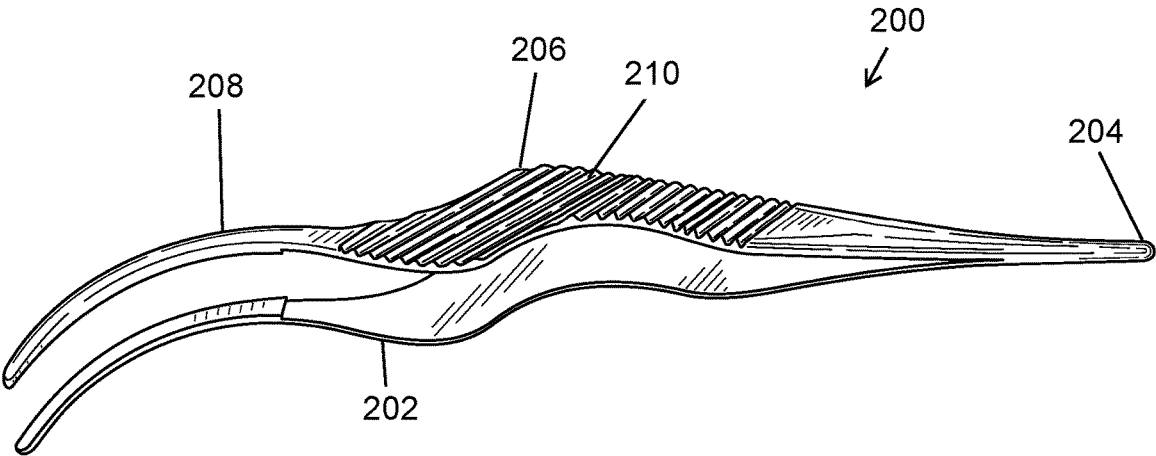
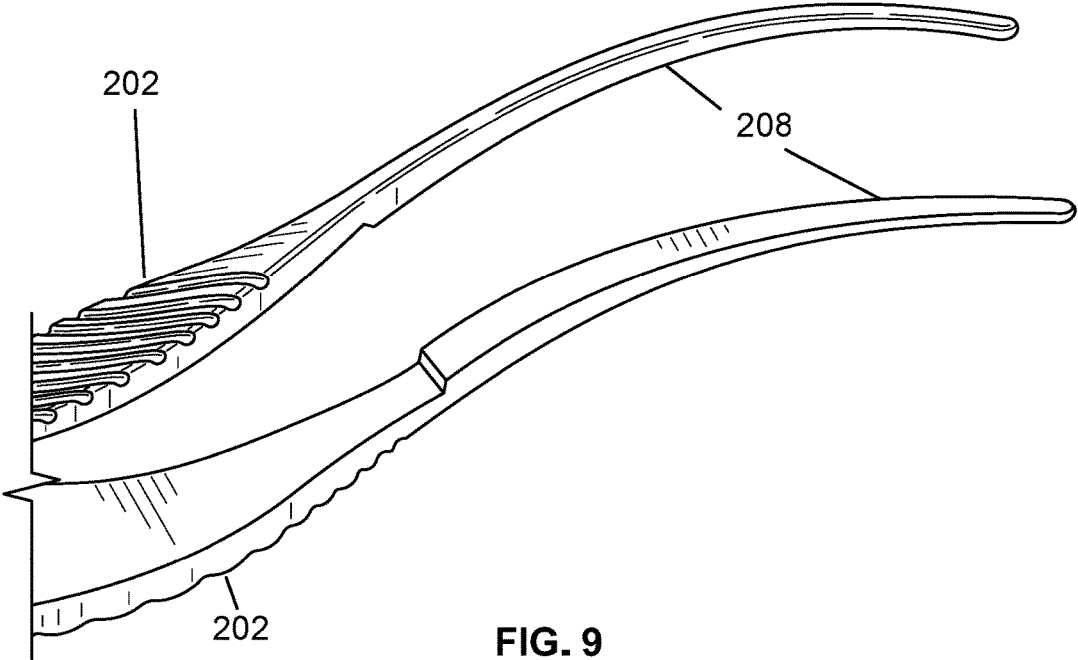
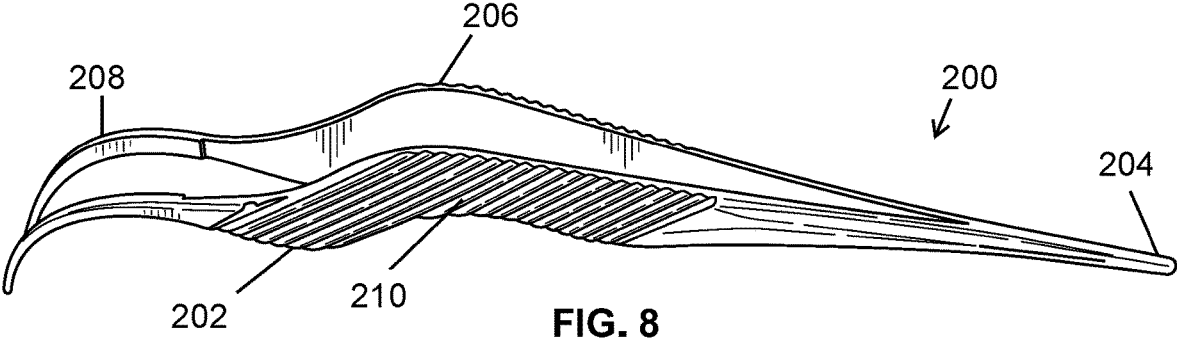

FIG. 7



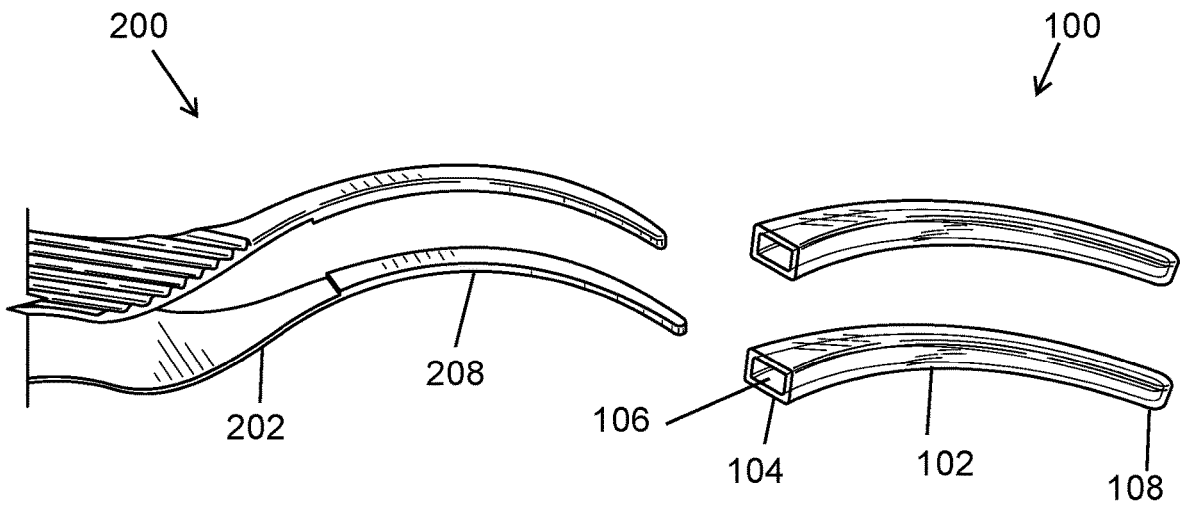

FIG. 10

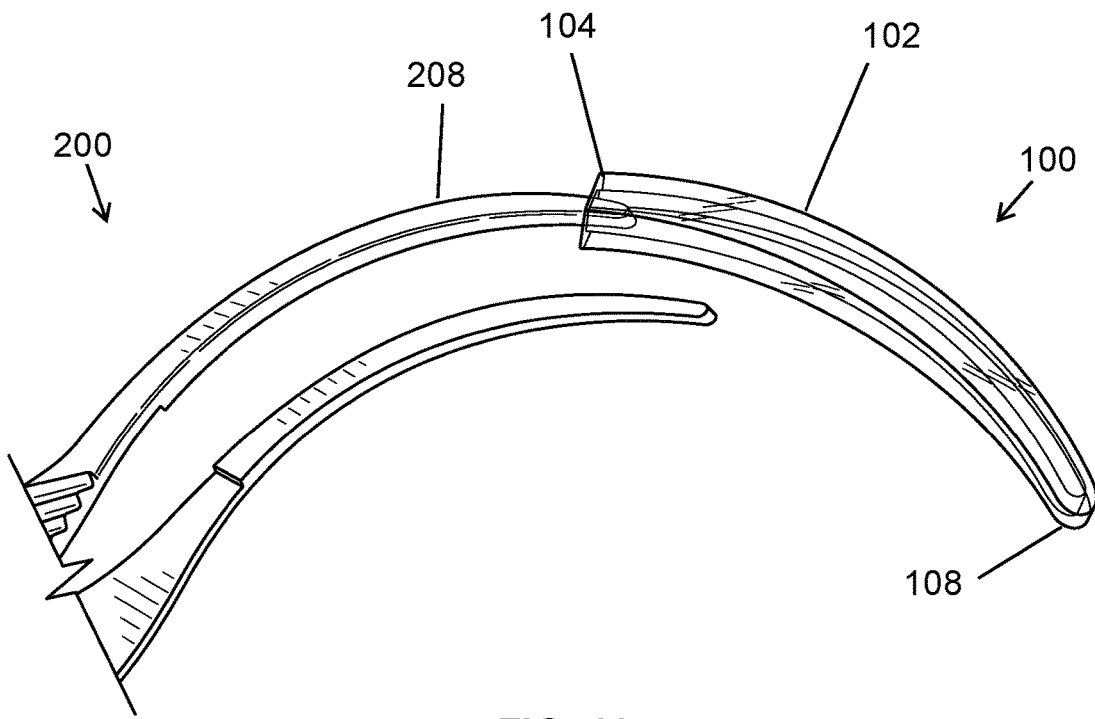

FIG. 11

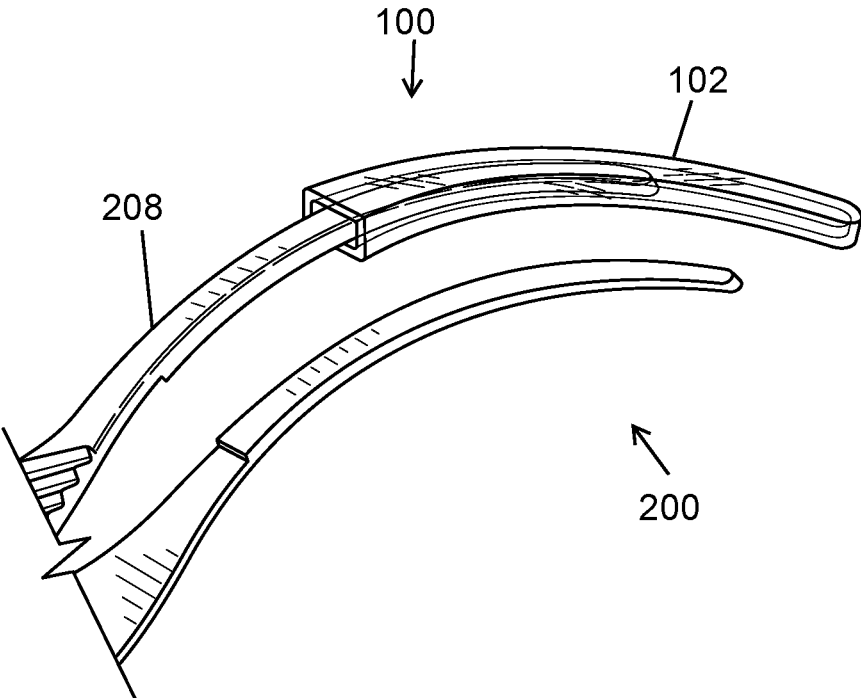

FIG. 12

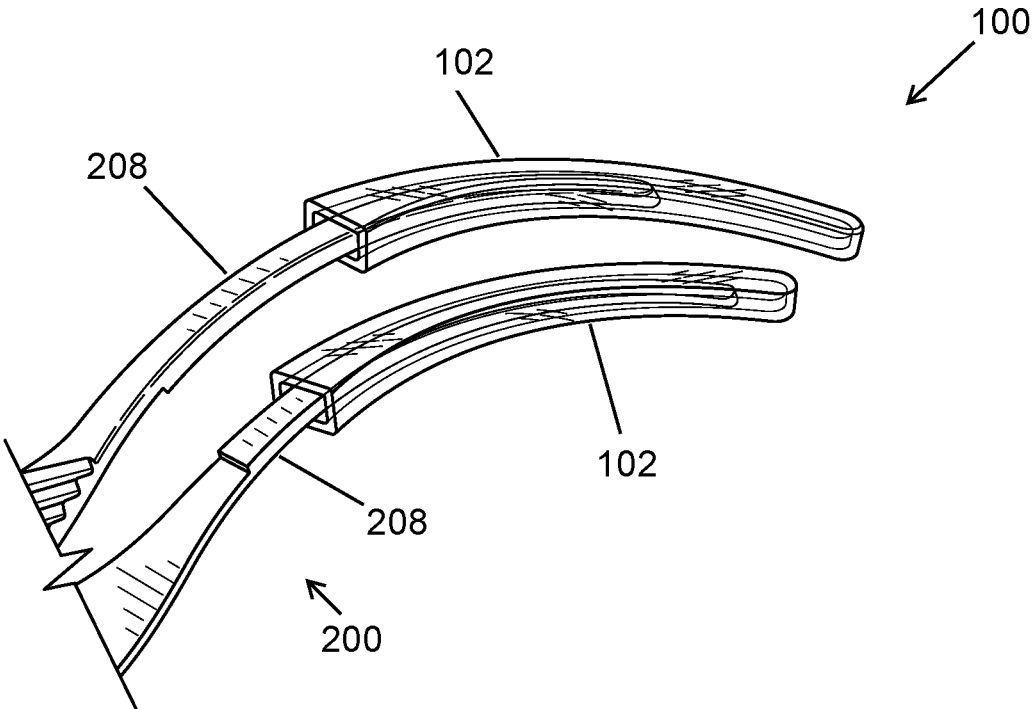
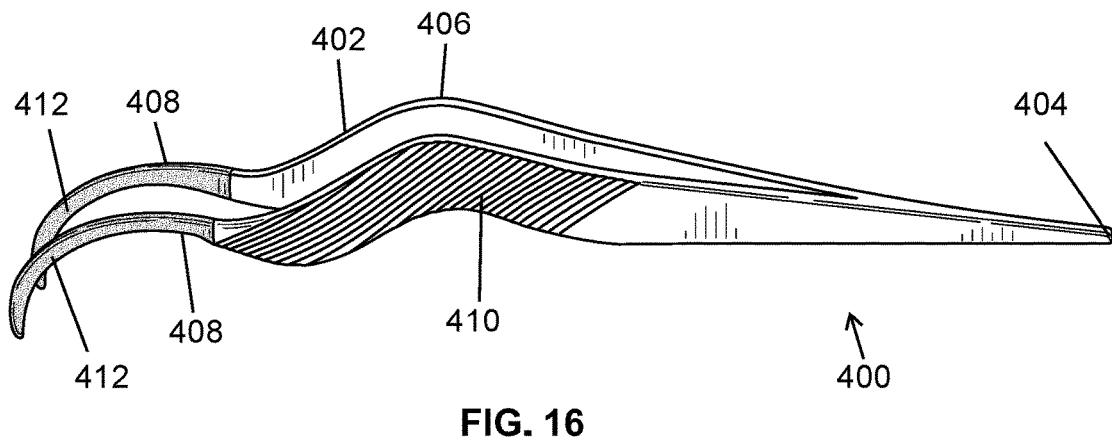
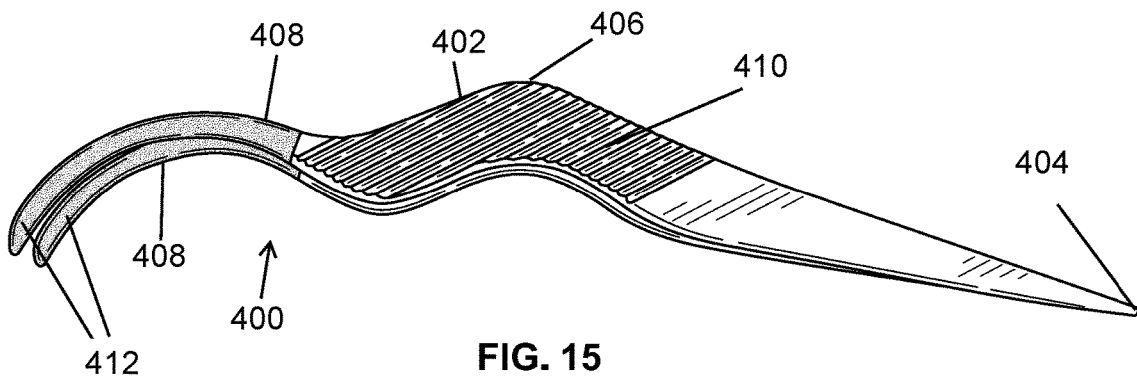
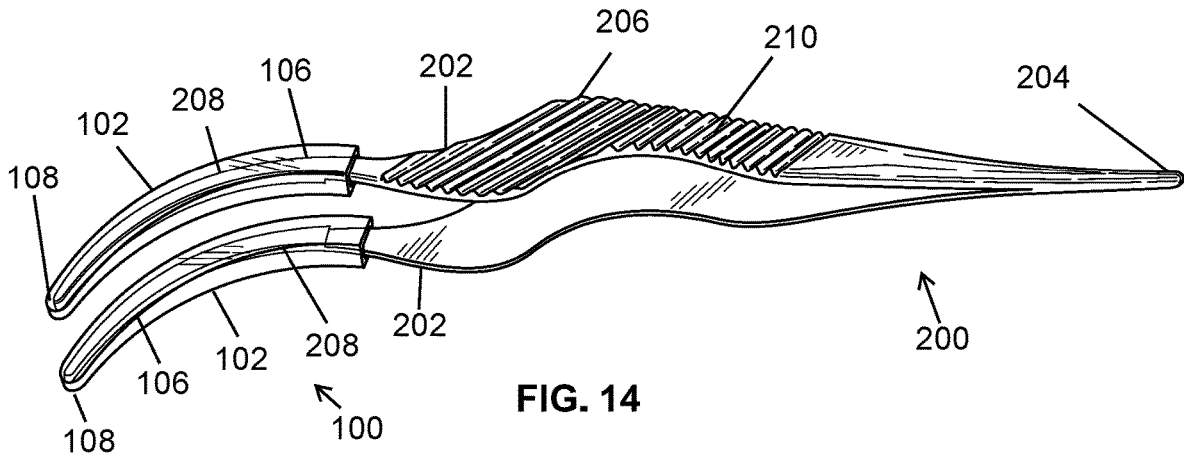

FIG. 13



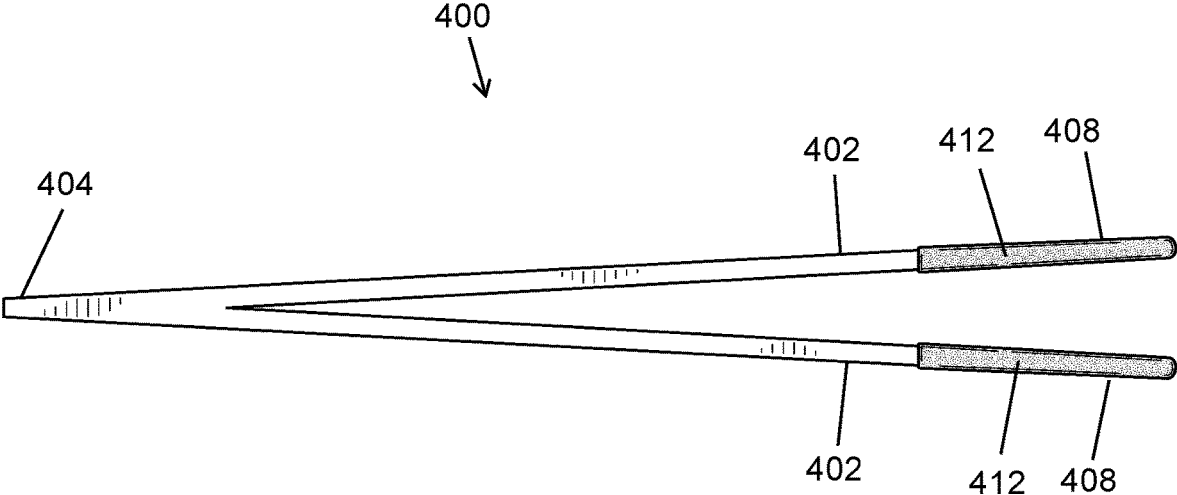

FIG. 17

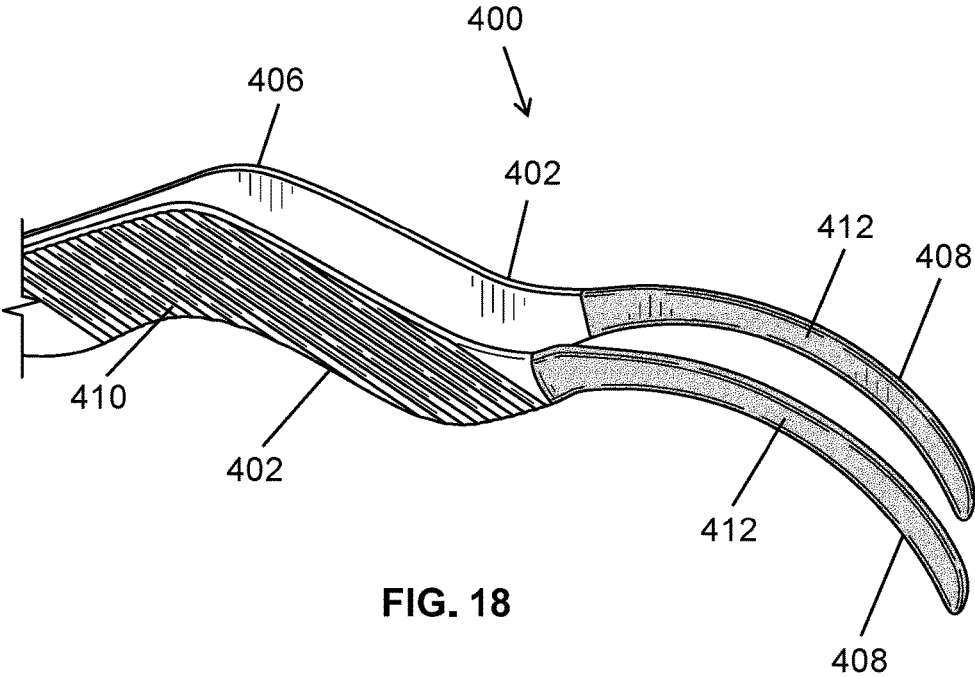
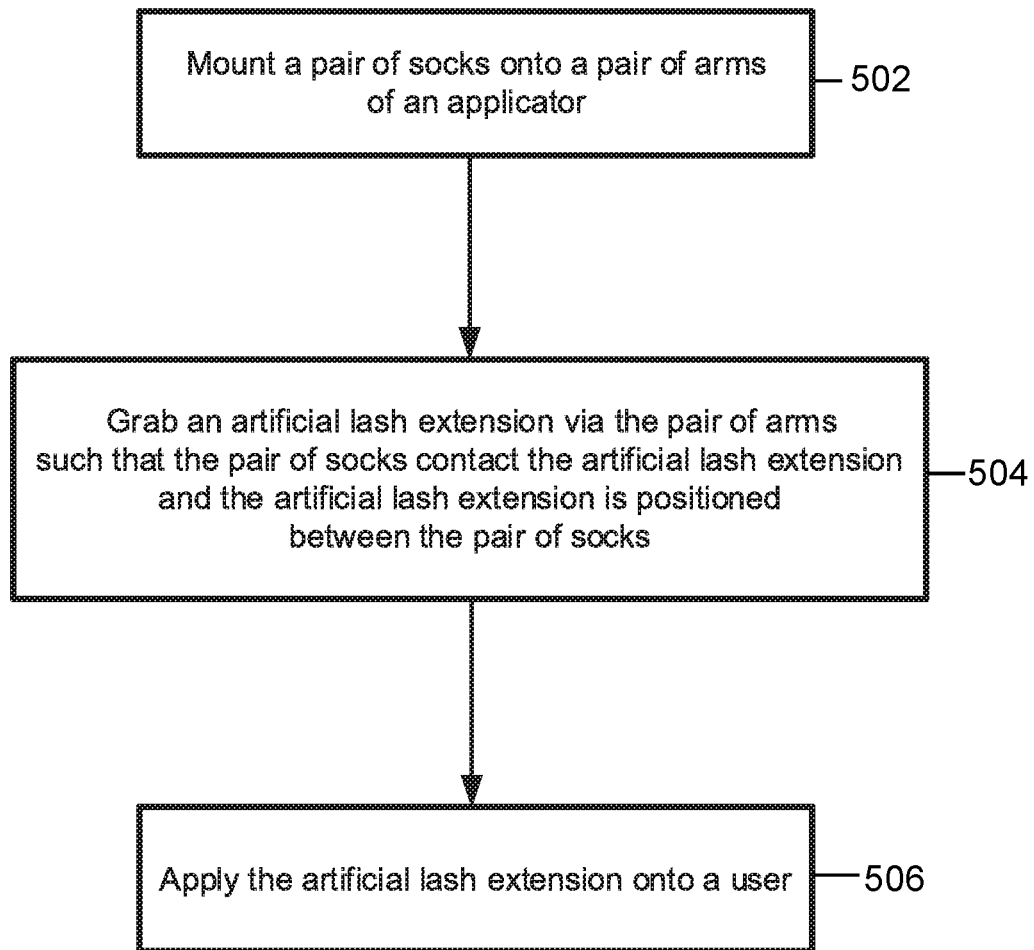

FIG. 18



500 ↗

FIG. 19

**SOCKS, APPLICATORS FOR LASH  
EXTENSIONS, AND METHODS OF  
MANUFACTURE AND USE THEREOF**

CROSS-REFERENCE TO RELATED PATENT  
APPLICATIONS

**[0001]** This patent application claims a benefit of U.S. Provisional Patent Application 62/792,048 filed 14 Jan. 2019, which is herein incorporated by reference in its entirety for all purposes.

TECHNICAL FIELD

**[0002]** This disclosure relates to lash extensions.

BACKGROUND

**[0003]** There is a difficulty in applying an artificial lash extension to a natural eyelash of a user using an applicator, which typically resembles a tweezer with curved tips. For most applicators, when the user applies an adhesive to the natural lashes and/or the artificial lash extension, the adhesive tends to stick to the tips of the applicators. The problem of the adhesive sticking to the tips of the applicator is that the lash extension can stick to the adhesive that adheres to the tips, thereby making the artificial lash extension more challenging to apply to the natural lash.

**[0004]** Moreover, because lashes are small and delicate, the tips of the applicator have to precisely clamp together. Fabricating such accurate applicators on a mass scale is challenging. In some cases, the quality of the metal has to have a high strength with precise bending ability. One problem with forming such quality applicators is the cost because the higher the accuracy and specification, the more expensive the metal.

SUMMARY

**[0005]** Generally, this disclosure discloses various socks, applicators for hosting these socks, applicators with non-stick coated tips, and methods of manufacture and use thereof. For example, this disclosure provides for an applicator with an arm having a tip portion. The tip portion can have a sock mounted thereon, where the sock may have a non-stick surface or be formed of a non-stick material or include a non-stick material. The tip portion can be externally coated with a non-stick coating. Regardless, the tip portion can be used to apply a lash extension to a natural eyelash of a user.

**[0006]** In an embodiment, an applicator may include an arm having a tip portion and a sock mounted onto the tip portion.

**[0007]** In an embodiment, a kit may include a package and an applicator contained in the package. The applicator may include an arm having a tip portion. A sock may be contained in the package. The sock may be mountable onto the tip portion, and an item may also be contained in the package. The item may be selected from a group including a lash extension engageable with the sock, an adhesive for a lash extension engageable with the sock, and a case with a slot structured to store a lash extension engageable with the sock.

**[0008]** In an embodiment, a method may include mounting a sock onto a tip of an arm of an applicator. A lash extension may be engaged with the sock.

**[0009]** In an embodiment, a method may include causing a sock to be mounted onto a tip of an arm of an applicator. The sock may be caused to engage a lash extension.

**[0010]** In an embodiment, an applicator may include an arm having a tip that is externally coated with a non-stick coating.

**[0011]** In an embodiment, a method may include coating an outer surface of a tip of an arm of an applicator with a non-stick coating.

**[0012]** In an embodiment, a kit may include a package and an applicator contained in the package. The applicator may include an arm having a tip portion that is externally coating with a non-stick coating. An item may be contained in the package, where the item may be selected from a group including a lash extension engageable with the non-stick coating, an adhesive for a lash extension engageable with the non-stick coating, and a case with a slot structured to store a lash extension engageable with the non-stick coating.

DESCRIPTION OF DRAWINGS

**[0013]** FIGS. 1-5 show an embodiment of a sock for mounting onto a tip of an applicator according to this disclosure.

**[0014]** FIGS. 6-9 show an embodiment of an applicator having a tip without a sock being mounted thereunto according to this disclosure.

**[0015]** FIGS. 10-14 show an embodiment of a technique for applying a sock to a tip of an applicator according to this disclosure.

**[0016]** FIGS. 15-18 show an embodiment of an applicator having a tip that is coated according to this disclosure.

**[0017]** FIG. 19 shows a flowchart of an embodiment of a method for applying an lash extension onto a natural eyelash of a user according to this disclosure.

DETAILED DESCRIPTION

**[0018]** Generally, this disclosure discloses various socks, applicators for hosting these socks, applicators with non-stick coated tips, and methods of manufacture and use thereof. For example, this disclosure provides for an applicator with an arm having a tip portion. The tip portion can have a sock mounted thereon, where the sock may have a non-stick surface or be formed of a non-stick material or include a non-stick material. The tip portion can be externally coated with a non-stick coating. Regardless, the tip portion can be used to apply a lash extension to a natural eyelash of a user. Note that this disclosure may be embodied in many different forms and should not be construed as necessarily being limited to various embodiments disclosed herein. Rather, these embodiments are provided so that this disclosure is thorough and complete, and fully conveys various concepts of this disclosure to skilled artisans.

**[0019]** FIGS. 1-5 show an embodiment of a sock for mounting onto a tip of an applicator according to this disclosure. In particular, a sock **100** includes a tubular body **102** having an open end portion **104**, an inner channel **106**, and a closed end portion **108**. The inner channel **106** extends between the open end portion **104** and the closed end portion **108**. The tubular body **102** may be longitudinally non-rectilinear. As such, the tubular body **102** may be longitudinally arcuate, but can be of any suitable non-rectilinear shape (e.g., sinusoidal, zigzag, pulsed, square, triangle, saw-tooth). However, such configuration can vary and the

tubular body **102** can be longitudinally rectilinear. Likewise, the inner channel **106** is longitudinally non-rectilinear. As such, the inner channel **106** may be longitudinally arcuate, but can be of any suitable non-rectilinear shape (e.g., sinusoidal, zigzag, pulsed, square, triangle, saw-tooth, hooked, curvilinear, etc.). However, such configuration can vary and the inner channel **106** can be longitudinally rectilinear. In an embodiment, the sock **100** may be monolithic (i.e., formed entirely of a single material). In another embodiment, the sock **100** may be non-monolithic (i.e., formed of multiple materials).

**[0020]** In an embodiment, as a result of the sock **100** being formed of or including a pliable material (e.g., rubber, silicon), when two socks **100** are squeezed together to grasp one or more artificial lashes or squeeze one or more artificial lashes with one or more natural lashes to redistribute an adhesive that holds the artificial lashes with the natural lashes, the two socks **100** may dynamically adjust for any misalignment of the tips of the applicator on which the socks **100** are mounted. As a result, the use of pliable socks **100** may allow for precision of the applicator to be relaxed (i.e., alignment of the tips may be less than optimal and strength of the material of the applicator may be reduced since the socks **100** may self-adjust based on the material thereof). In an embodiment, the socks **100** may extend along an entirety of the tips of the applicator. Alternatively, the socks **100** may extend along any sub-portion (e.g., tip, central region, region near the base of the tips) of the applicator.

**[0021]** The tubular body **102** includes at least one of include rubber, silicon, plastic, metal, wood, glass, polytetrafluoroethylene (PTFE), shape memory material (e.g., alloy, polymer, plastic), foam, fabric, or another suitable material. The tubular body **102** may be transparent or translucent such that the inner channel **106** is visibly identifiable when externally handling the tubular body **102**. Alternatively, the tubular body **102** can be opaque such that the inner channel **106** is not visibly identifiable when externally handling the tubular body **102**. The tubular body **102** is solid, but can include a plurality of openings that are spaced apart from each other. For example, the tubular body **102** can be perforated or latticed structured. The tubular body **102** may be flexible (i.e., easily bent) and can be at least one of elastic or resilient. However, the tubular body **102** can be rigid (i.e., resistant to bending).

**[0022]** The tubular body **102** may have a lateral cross-section is polygonal. As such, the lateral cross-section of the tubular body **102** is rectangular, but can be square, trapezoidal, triangular, or other suitable polygonal shapes. However, note that the lateral cross section can be non-polygonal, such as circular, oval, or other suitable non-polygonal shapes. Note that the tubular body **102** has a symmetrical lateral cross-section, but this configuration can vary and the tubular body **102** can have an asymmetrical lateral cross-section. For example, the tubular body **102** can have a square, rectangle, triangle, circular, oval, pentagon, hexagon, octagon, O-shape, D-shape, open, closed, or polygonal cross-section, whether internal or external, whether uniform or varying, whether symmetrical or asymmetrical.

**[0023]** The tubular body **102** has an outer surface **110**. The outer surface **110** can be textured to engage (e.g., contact) at least one of a lash extension or an adhesive for the lash extension. The outer surface **110** can have a plurality of projections (or depressions) structured to engage at least one of a lash extension or an adhesive for the lash extension. The

outer surface **110** is flat, but may alternatively not be flat. For example, the outer surface **110** can be inwardly or outwardly arcuate or another non-flat shape. The outer surface **110** can be at least one of a smooth surface, a rough surface, a textured surface, bumped surface, a spiked surface, or a knurled surface. The outer surface **110** can be configured such that a lash extension can avoid freely sliding thereon (e.g., friction enhancement) or such that the lash extension can avoid sticking thereto (e.g., non-stick).

**[0024]** The outer surface **110** is non-stick relative to at least one of a lash extension or an adhesive for a lash extension. For example, the outer surface can have a coefficient of friction, whether static or dynamic, relative to at least one of a lash extension or an adhesive for a lash extension that may about be 0.5 or higher, such as about 0.6, 0.7, 0.8, 0.9, 1, 1.1, 1.2, 1.3, 1.4, 1.5, or higher, including any intermediate values in between.

**[0025]** In general, the tubular body **102** of the sock **100** may be configured with the inner channel **106** that fits a tip of an applicator. That is, the inner channel **106** of the sock **100** may have dimensions that enables the sock **100** to cover a tip and be held onto the tip with a friction fit. For example, if the tip has a rectangular cross-section, the inner channel **106** may have a corresponding lateral cross-section with a rectangular cross-section. More specifically, the inner channel **106** may have a lateral cross-section that is polygonal. As such, the lateral cross-section of the inner channel is rectangular, but can be square, trapezoidal, triangular, or other suitable polygonal shapes. However, the lateral cross-section can be non-polygonal, such as circular, oval, or other suitable non-polygonal shapes. Note that the lateral cross-section of the inner channel **106** is symmetrical, but can be asymmetrical. For example, the inner channel **106** can have a square, rectangle, triangle, circular, oval, pentagon, hexagon, octagon, O-shape, D-shape, open, closed, or polygonal cross-section, whether internal or external, whether uniform or varying, whether symmetrical or asymmetrical.

**[0026]** The inner channel **106** may have an inner surface **112** that is textured to engage (e.g., contact) a tip of an arm of an applicator. The inner surface **112** can have a plurality of projections (or depressions) structured to engage a tip of an arm of an applicator. The inner surface **112** is flat, but may not be flat. For example, the inner surface **112** can be inwardly or outwardly arcuate or another non-flat shape. The inner surface **112** can be at least one of a smooth surface, a rough surface, a textured surface, bumped surface, a spiked surface, or a knurled surface. In an embodiment, the inner channel **106** may have a feature, such as a protrusion, that may slide over a feature, such as a protrusion, of the tip and/or arm of the applicator so as to resist sliding off of the tip of the applicator.

**[0027]** The closed end portion **108** can be partially closed off (e.g., more than about 0, 5, 10, 15, 20, 25, 30, 35, 40, 45, 50, 55, 60, 65, 70, 75, 80, 85, 90, or 95 percent) or fully closed off (e.g. about 100 percent). In some situations, the tubular member **102** does not include the closed end portion **108**, but instead that end portion is open, thereby configuring the sock **100** as a tube or a sleeve with at least two open end portions (e.g. **104** and **108**) in fluid communication with each other via the inner channel **106**.

**[0028]** FIGS. 6-9 show an embodiment of an applicator having a tip without a sock being mounted thereon according to an embodiment. In particular, an applicator **200** (e.g., tweezer, tongs) may include a pair of arms **202** having a pair

of medial portions 206 and a pair of grasping tips 208. The pair of arms 202 may be joined at a common point 204 such that the pair of medial portions 206 are positioned between the common point 204 and the pair of grasping tips 208 and such that the pair of arms 208 define a default position shaped in a V-shape. As such, the pair of arms 202 are in the default position when defining the V-shape via the common point 204. Therefore, the applicator 200 includes the first arm 202 having the first grasping tip 208 that is arcuate and the second arm 202 having the second grasping tip 208 that is arcuate.

**[0029]** Each arm of the pair of arms 202 has an inner side and an outer side such that the inner sides face each other in the default position and such that the pair of arms 202 are symmetrical to each other at the medial portions 206 or at the grasping tips 208. It should be understood that non-symmetrical embodiments are possible.

**[0030]** Each of the medial portions 206 of the pair of medial portions 206 may be humped such that a concave shape is defined thereby (e.g., for resting against a user's cheekbone or user's nose bridge). Likewise, each grasping tip 208 of the pair of grasping tips 108 may be arcuate such that the shape matches or corresponds to any eyelash line of a user. As such, the concave shapes and the arcuate shapes are respectively positionally consecutive and respectively face a same direction respectively lateral to the pair of arms 202. Correspondingly, each medial portion of the pair of medial portions 206 and each grasping tip of the pair of grasping tips 208 consecutively and longitudinally extend such that a valley is defined therebetween. These valleys respectively longitudinally oppose each other in the default position.

**[0031]** Each medial portion of the pair of medial portions 206 may have the outer side that has a textured portion 210, in this case parallel grooves and ridges, but can also be non-textured. The outer sides of the medial portions 206 face opposite directions.

**[0032]** FIGS. 10-14 show an embodiment of a technique for applying a sock to a tip of an applicator according to this disclosure. In particular, a technique 300 is used for applying the sock 100 to the tip 208 of the arm 202 of the applicator 200, whether this is done removably (e.g., user can selectively mount and unmount) or permanently (e.g., user cannot selectively unmount unless breaking or disabling a sock and/or tip of the applicator). The open end portion 104 of the sock 100 may be oriented to be aligned with the tip 208 of the applicator 200. Then, the tubular body 102 is at least one of mounted or slid onto the tip 208 through the open end portion 104, while the tip 208 is held steady or rotated, until the closed end portion 108 of the sock 100 engages the tip 208 (or before that point if desired). However, this approach can be reversed where the tubular body 102 is held steady or rotated and the tip 208 is inserted into the open end portion 102 of the sock 100 until the tip 208 engages the closed end portion 108 of the sock 100 (or before that point if desired). As such, the sock 100 can at least one of snugly or non-snugly at least one of mount or slide onto the tip 208 via the open end portion 104 or vice versa. In some embodiments, when the tubular body 102 is longitudinally arcuate and the tip 208 is longitudinally arcuate, then the tubular body 102 can mount onto the tip 208 or vice versa only in a specific manner (e.g., arcs are co-aligned to form bigger arc or not sinusoidally oriented). In some embodiments, when the tubular body 102 is mounted onto the tip 208 or

vice versa, the tubular body 102 is not able to rotate or freely rotate about the tip 208 or vice versa. In some embodiments, if the tip 208 avoids engaging the closed end portion 108, then the sock 100 can still remain on the tip 208 and, in some embodiments, can be still be used to apply a lash extension to a natural eyelash of a user. Note that the sock 100 can mount onto the tip 208 or vice versa manually by a user or automatically by a machine, as now known to skilled artisans. As such, the technique 300 can include mounting the sock 100 onto the tip 208 of the arm 202 of the applicator 200 and engaging a lash extension with the sock 100. Likewise, the technique 300 can include causing the sock 100 to be mounted onto the tip 208 of the arm 202 of the applicator 200 and causing the sock 100 to engage a lash extension.

**[0033]** When the tubular body 102 has a lateral cross-section having an open shape (e.g., U-shape, C-shape, V-shape), then the tubular body 102 may not be fully tubular, but be more tubular-like or bar-like. As such, this body 102 can still at least one of slide or mount, although not necessarily through the open end portion 104 (although this is possible), yet via the inner channel 106 snapping onto the tip 208. Note that a vice versa configuration is possible when the tip 208 at least one of slides or inserts into the inner channel 106, although not necessarily through the open end portion 104 (although this is possible), yet via the inner channel snapping onto the tip 208. Note that in such cases, in order to maximize the body 102 not falling off or sliding off the tip 208, at least one of the body 102 or the tip 208 can include various attachment enhancers. For example, some of such enhancers can include magnets, rails, tracks, mate/female structures, interlocks, or other suitable configurations.

**[0034]** In some embodiments, instead of the sock 100, there can be a single strip (of any shape) or a plurality of strips (of any shapes) that can be spaced apart from each other, whether in a rectilinear or non-rectilinear pattern, that can secure to or the tip 208, whether permanently or removably. For example, such securing can be via adhering, magnetizing, mating, interlocking, or other suitable techniques. As such, the single strip or the strips that are spaced apart from each other on the tip 208 can be configured to function as the outer surface 110 of the sock 100.

**[0035]** In some embodiments, once the sock 100 is mounted onto the tip 208 or vice versa, there can be a difference in a coefficient of friction, whether static or dynamic, between the sock 100 and the applicator 200. For example, the arm 202 can include a first outer surface (or another external or internal portion of that arm) having a first coefficient of friction relative to at least one of a lash extension or an adhesive for the lash extension. For example, the tip 208 can include the first outer surface. Likewise, the tubular body 102 can include a second outer surface (or another external or internal portion of that body) having a second coefficient of friction relative to at least one of the lash extension or the adhesive for the lash extension. For example, the outer surface 110 can include the second outer surface. As such, the difference in the coefficient of friction, whether static or dynamic, between the sock 100 and the applicator 200 can occur when the second coefficient of friction is not identical to the first coefficient of friction. For example, the second coefficient of friction is higher than the first coefficient of friction (although in other embodiments can be identical or lower). Based on such difference

in the coefficient of friction, if two socks **100** are mounted onto two arms **202**, then the socks **100** are structured to grasp the lash extension when the lash extension is interposed between the socks **100**, even of the socks **100** or the lash extension carry an adhesive.

**[0036]** In some embodiments, the sock **100** and the applicator **200** can be included in a kit. As such, the kit can include a package (e.g., plastic support base with lid, envelope, cardboard box), the applicator **200** contained in the package, the sock **100** contained in the package, where the sock **100** can be already mounted onto the tip **208** within the package or not mounted onto the tip **208** within the package (e.g., user can do so upon use). For example, the package can include a plurality of socks **100**, which can function as spares, whether any of such socks **100** are or are not mounted onto tips **208**. The kit can include an item contained in the package. For example, the item can include a lash extension that is engageable with the sock **100**, an adhesive for a lash extension that is engageable with the sock **100**, and a case with a slot structured to store a lash extension that is engageable with the sock **100**. For example, the lash extension can extend out of the slot to be grasped from the slot via the tip **208**, whether with or without the sock **100** mounted thereon. For example, the adhesive which can be pressure-sensitive, may be a waterproof (semi-permanent) glue, mascara, or some other co-polymer solution having an adhesive quality. Although latex-based adhesives are generally avoided to avoid irritation of the individual's eyelid (e.g., due to an allergic reaction), adhesives can include various other natural and/or chemical ingredients. Examples of possible adhesives include: Acrylates/ethylhexyl acrylate copolymer, aqua, propylene glycol, cetareth-25, hydrogenated castor oil, glycerin, phenoxyethanol, 2-bromo-2-nitropropane-1, 3-diol, methylchloroisothiazolinone, methylisothiazolinone, methylparaben, and optionally a color agent (e.g., black 2 (C177266)); Polyterpene, styrene/isoprene copolymer, petrolatum, polyisobutene, microcrystalline wax (cera microcristalina, cire microcristalline), hydrogenated styrene/methyl styrene/indene copolymer, styrene/VA copolymer, and optionally an antioxidant (e.g., butylated hydroxytoluene (BHT)); Chlorine dioxide, p-anisic acid, biotin, *lavandula angustifolium* oil, propylene glycol, water, 2-ethylhexyl acrylate, and optionally a preservative (e.g., benzalkonium chloride); and Acrylate copolymer and water. Note that many other adhesive compositions are possible and, in fact, may be desirable for individuals having certain allergies, desiring certain fixation duration (also referred to as "permanency" of the lash extensions), or other use cases.

**[0037]** Semi-permanent clusters of lash extensions may be applied with a Federal Drug Administration-approved (FDA-approved) adhesive that achieves a strong bond. Such adhesives generally include cyanoacrylate. Different types of cyanoacrylates (e.g., ethyl, methyl, propyl, butyl, and octyl) have been designed for bonding to different surfaces. For example, adhesives made from methyl-2-cyanoacrylate are designed to bond a smooth surface (e.g., the lash extension) to a porous surface (e.g., the natural eyelash), but not on the skin as it may cause irritation.

**[0038]** The adhesive may be a semi-permanent glue or mascara. The adhesive can include an oil-soluble polymer or a water-soluble polymer that helps to enhance adhesion and substantively of the lash extension to the natural eyelashes. The adhesive may be a waterproof formulation that allows

the set of lash extensions to remain affixed to the natural lashes for longer periods of time (e.g., days, weeks, or months).

**[0039]** Although latex-based adhesives are generally avoided to avoid eyelid irritation (e.g., due to an allergic reaction), adhesives can include various other natural ingredients (e.g., sugar or honey) and/or chemical ingredients. For example, copolymer is often a main ingredient in many adhesive formulations. The adhesive could be a commercially-available adhesive for conventional lash extensions or a specialized composition for use with the set of lash extensions described herein. The adhesive could be clear or colored (e.g., milky white or black to emulate mascara).

**[0040]** In some embodiments, the applicator **200** can be used to perform a process of applying a lash extension to a natural eyelash of a user. The user may initially apply an adhesive to a natural eyelash to which the lash extension is to be applied by using a mascara wand or otherwise. Alternatively, the adhesive may be applied to the lash extension prior to applying the lash extension to the natural eyelash. The process can include causing a lash extension (or another object) to be resiliently grasped (e.g., by hairs, by base) via clamping between the socks **100**. Further, the process can include causing the lash extension (or another object) to be released or placed onto a natural lash of the user (e.g., upper or lower side of upper or lower natural lash). Therefore, the method can enable a self-application of the lash extension via the applicator **200**. In another embodiment, the user may use his or her fingers to apply the lash extension to the natural eyelash with the adhesive applied to the natural lash and/or the lash extension. As such, since the arms **202** have longitudinally extending non-tip portions (e.g., medial portions **106**), then the longitudinally extending non-tip portions can be lateral to the natural eyelash (e.g., to right thereof or to left thereof) when the lash extension is released onto the natural lash (e.g., for adhering, magnetizing, fastening, securing).

**[0041]** After the lash extension is placed onto the natural eyelash and weakly adhered thereto by an adhesive, the user may squeeze the tips **208** on the natural lashes and lash extensions, thereby causing the adhesive to better connect the lash extension to the natural eyelash by more evenly distributing the adhesive as the socks **100** are pressed together. Because the socks **100** may include non-stick material or coated with a non-stick material, the adhesive may not or may minimally stick thereto.

**[0042]** FIGS. 15-19 show an embodiment of an applicator having a tip that is coated according to this disclosure. In particular, an applicator **400** may be similarly structured to the applicator **200**. As such, the applicator **400** also includes a plurality of arms **402** joined at a common point **404**, each having a medial portion **406** and tip **408**. However, the tip portion **408** has an outer surface **410** that is coated with a non-stick coating **412**. Although the tip **408** is all-around coated with the non-stick coating **412**, this is not required and only a portion of the outer surface **410** can be coated. For example, at least the outer surface **410** that is inner (e.g., facing or exposed to opposing tip) can be coated with the non-stick coating **412**. For example, for each of the arms **402**, only the outer surface **410** that is inner can host the non-stick coating **412**. Such extension of the non-stick coating **412** can be rectilinear or non-rectilinear or patterned along an X, Y, or Z plane in any manner (e.g., single line, parallel lines, polka dot pattern).

[0043] Note that the non-stick coating 412 can be coated on the outer surface 410, whether continuously or distributed as a pattern, whether rectilinear or non-rectilinear. In some situations, the sock 100 can be mounted over the tip 408 having the non-stick coating 412 such that the non-stick coating 412 extends within the inner channel 106 of the sock 100 and the non-stick coating 412 extends between the tip 408 and the sock 100.

[0044] The non-stick coating 412 can be applied (e.g., layering, painting, adhering, melting, bathing, sprinkling, powdering, dusting) onto the tip 408 after the tip 408 has been manufactured (e.g., formed, cast, 3D-printed). The non-stick coating 412 can be uniform in thickness or vary in thickness on the tip 408. The non-stick coating 412 can be applied in accordance with a predefined pattern or randomly to a predetermined area of the tip 408. The non-stick coating 412 can be configured such that a lash extension can avoid freely sliding thereon (e.g., friction enhancement) or such that the lash extension can avoid sticking thereto (e.g., non-stick). For example, the non-stick coating 412 can include rubber, silicon, plastic, polytetrafluoroethylene (PTFE), a shape memory material (e.g. alloy, polymer), foam, gel, or other materials.

[0045] In some situations, the tip 208 can mate (e.g., male-female), interlock, magnetize, suction, hook-and-loop, adhere, or otherwise attach to a symmetrical or asymmetrical piece of material (e.g. square-shaped, round-shaped, oval-shaped, rectangle-shaped, arc-shaped, triangle-shaped, sine-shaped, polygon-shaped) similar to the non-stick coating 412 or the sock 100 or vice versa. This piece of material can include rubber, silicon, plastic, metal, wood, glass, polytetrafluoroethylene (PTFE), shape memory (e.g., alloy, polymer), foam, gel, fabric, or other materials. In some situations, the tip 208 or the tip 408 can be non-smooth, rough, textured, knurled, spiked, bumped, or others.

[0046] FIG. 19 shows a flowchart of an embodiment of a method for applying a lash extension onto a natural eyelash of a user according to this disclosure. In particular, a method 500 includes a plurality of blocks 502-506, which can be performed via the sock 100, the applicator 200, or the applicator 400. The user can include a live or dead human, whether male or female, a live animal or dead animal, whether male or female, a doll, a mannequin, a robot, a mask, or other suitable structures. As explained above, the method 500 can be used with various applicators disclosed herein.

[0047] Block 502 includes mounting or sliding a pair of socks 100 onto a pair of arms 202 of the applicator 100. The pair of arms 202 has a pair of tips 208. As such, the pair of socks 100 are mounted or slid onto the applicator 200 via the pair of tips 208. Since the pair of socks 100 can have a pair of closed end portions 108 and a pair of open end portions 104, the pair of socks 100 can be at least one of mounted or slid onto the pair of tips 208 via mounting or sliding the open end portions 108 onto the pair of tips 208. This mounting or sliding can occur until the pair of closed end portions 108 contact the pair of tips 208. When the pair of socks 100 do not have the closed end portions 108, then such sliding or mounting can be until the pair of socks 100 are sufficiently mounted or slid onto the pair of tips 208 such that the pair of socks 100 can avoid freely sliding off from the pair of tips 208.

[0048] Block 504 includes grabbing a lash extension via the pair of arms 202 such that the pair of socks 100 contact

the lash extension and the lash extension is positioned between the pair of socks 100. The pair of socks 100 can be configured such that the lash extension can avoid freely sliding thereon (e.g., friction enhancement) or such that the lash extension can avoid sticking thereto (e.g., non-stick).

[0049] Block 506 includes applying the lash extension onto the user.

[0050] Based on above, the applicator 200 can comprise the arm 202 having the tip portion 208 and the sock 100 mounted onto the tip portion 208. Likewise, the kit can comprise the package, the applicator 200 contained in the package, where the applicator 200 includes the arm 202 having the tip portion 208, and the sock 100 contained in the package, where the sock 100 is mountable onto the tip portion 208. Similarly, some methods can comprise mounting the sock 100 onto the tip 208 of the arm 202 of the applicator 200 and engaging a lash extension with the sock 100. Further, some methods can comprise causing the sock 100 to be mounted onto the tip 208 of the arm 202 of the applicator 200 and causing the sock 100 to engage a lash extension. Additionally, the applicator 400 can comprise the arm 402 having the tip 408 that is externally coated with the non-stick coating 412. Also, some methods can comprise coating the outer surface 410 of the tip 408 of the arm 402 of the applicator 400 with the non-stick coating 412. Furthermore, the kit can comprise a package and the applicator 400 contained in the package, where the applicator 400 includes the arm 402 having the tip portion 408 that is externally coating with the non-stick coating 412. Further, a pair of socks 100 can be used for applying artificial eyelashes onto natural eyelashes, where each of the socks 100 can comprise: an elongated portion (e.g., tubular body 102) that defines (i) the inner channel 106 configured to be mounted to and retained on the tip 208 of the applicator 200 used to apply the artificial eyelashes onto the natural eyelashes, and (ii) a lateral portion that enables a user to grasp artificial eyelashes when squeezed together when positioned on respective tips 208 of the applicator 200.

[0051] Various terminology used herein can imply direct or indirect, full or partial, temporary or permanent, action or inaction. For example, when an element is referred to as being “on,” “connected,” or “coupled” to another element, then the element can be directly on, connected, or coupled to another element or intervening elements can be present, including indirect or direct variants. In contrast, when an element is referred to as being “directly connected” or “directly coupled” to another element, then there are no intervening elements present.

[0052] As used herein, various singular forms “a,” “an” and “the” are intended to include various plural forms as well, unless specific context clearly indicates otherwise.

[0053] As used herein, various presence verbs “comprises,” “includes” or “comprising,” “including” when used in this specification, specify a presence of stated features, integers, steps, operations, elements, or components, but do not preclude the presence or addition of one or more other features, integers, steps, operations, elements, components, or groups thereof.

[0054] As used herein, a term “or” is intended to mean an inclusive “or” rather than an exclusive “or.” That is, unless specified otherwise, or clear from context, “X employs A or B” is intended to mean any of a set of natural inclusive permutations. That is, if X employs A; X employs B; or X

employs both A and B, then “X employs A or B” is satisfied under any of the foregoing instances.

**[0055]** As used herein, a term “or others,” “combination,” “combinatory,” or “combinations thereof” refers to all permutations and combinations of listed items preceding that term. For example, “A, B, C, or combinations thereof” is intended to include at least one of: A, B, C, AB, AC, BC, or ABC, and if order is important in a particular context, also BA, CA, CB, CBA, BCA, ACB, BAC, or CAB. Continuing with this example, expressly included are combinations that contain repeats of one or more item or term, such as BB, AAA, AB, BBC, AAABCCCC, CBBAAA, CABABB, and so forth. Skilled artisans understand that typically there is no limit on number of items or terms in any combination, unless otherwise apparent from the context.

**[0056]** As used herein, unless otherwise defined, all terms (including technical and scientific terms) used herein have the same meaning as commonly understood by one of ordinary skill in an art to which this disclosure belongs. Various terms, such as those de-fined in commonly used dictionaries, should be interpreted as having a meaning that is consistent with a meaning in a context of a relevant art and should not be interpreted in an idealized or overly formal sense unless expressly so defined herein.

**[0057]** As used herein, relative terms such as “below,” “lower,” “above,” and “upper” can be used herein to describe one element’s relationship to another element as illustrated in the set of accompanying illustrative drawings. Such relative terms are intended to encompass different orientations of illustrated technologies in addition to an orientation depicted in the set of accompanying illustrative drawings. For example, if a device in the set of accompanying illustrative drawings were turned over, then various elements described as being on a “lower” side of other elements would then be oriented on “up-per” sides of other elements. Similarly, if a device in one of illustrative figures were turned over, then various elements described as “below” or “beneath” other elements would then be oriented “above” other elements. Therefore, various example terms “be-low” and “lower” can encompass both an orientation of above and below.

**[0058]** As used herein, a term “about” or “substantially” refers to a +/-10% variation from a nominal value/term. Such variation is always included in any given value/term provided herein, whether or not such variation is specifically referred thereto.

**[0059]** Features described with respect to certain embodiments may be combined in or with various some embodiments in any permutational or combinatory manner. Different aspects or elements of example embodiments, as disclosed herein, may be combined in a similar manner.

**[0060]** Although various terms first, second, third, and so forth can be used herein to describe various elements, components, regions, layers, or sections, these elements, components, regions, layers, or sections should not necessarily be limited by such terms. These terms are used to distinguish one element, component, region, layer or section from another element, component, region, layer or section. Thus, a first element, component, region, layer, or section discussed below could be termed a second element, component, region, layer, or section without departing from various teachings of this disclosure.

**[0061]** Features described with respect to certain example embodiments can be combined and sub-combined in or with

various other example embodiments. Also, different aspects or elements of example embodiments, as disclosed herein, can be combined and sub-combined in a similar manner as well. Further, some example embodiments, whether individually or collectively, can be components of a larger system, wherein other procedures can take precedence over or otherwise modify their application. Additionally, a number of steps can be required before, after, or concurrently with example embodiments, as disclosed herein. Note that any or all methods or processes, at least as disclosed herein, can be at least partially performed via at least one entity in any manner.

**[0062]** Example embodiments of this disclosure are described herein with reference to illustrations of idealized embodiments (and intermediate structures) of this disclosure. As such, variations from various illustrated shapes as a result, for example, of manufacturing techniques or tolerances, are to be expected. Thus, various example embodiments of this disclosure should not be construed as necessarily limited to various particular shapes of regions illustrated herein, but are to include deviations in shapes that result, for example, from manufacturing.

**[0063]** Any or all elements, as disclosed herein, can be formed from a same, structurally continuous piece, such as being unitary, or be separately manufactured or connected, such as being an assembly or modules. Any or all elements, as disclosed herein, can be manufactured via any manufacturing processes, whether additive manufacturing, subtractive manufacturing, or other any other types of manufacturing. For example, some manufacturing processes include three dimensional (3D) printing, laser cutting, computer numerical control routing, milling, pressing, stamping, vacuum forming, hydroforming, injection molding, lithography, and so forth.

**[0064]** Various corresponding structures, materials, acts, and equivalents of all means or step plus function elements in various claims below are intended to include any structure, material, or act for performing the function in combination with other claimed elements as specifically claimed. Various embodiments were chosen and described in order to best disclose various principles of this disclosure and various practical applications thereof, and to enable others of ordinary skill in a pertinent art to understand this disclosure for various embodiments with various modifications as are suited to a particular use contemplated.

**[0065]** This detailed description has been presented for various purposes of illustration and description, but is not intended to be fully exhaustive or limited to this disclosure in various forms disclosed. Many modifications and variations in techniques and structures will be apparent to those of ordinary skill in an art without departing from a scope and spirit of this disclosure as set forth in various claims that follow. Accordingly, such modifications and variations are contemplated as being a part of this disclosure. Scope of this disclosure is defined by various claims, which include known equivalents and unforeseeable equivalents at a time of filing of this disclosure.

1. An applicator comprising:
  - an arm having a tip portion; and
  - a sock mounted onto the tip portion.
2. The applicator of claim 1, wherein the sock is longitudinally non-rectilinear.
3. The applicator of claim 2, wherein the sock is longitudinally arcuate.

4. The applicator of claim 1, wherein the sock includes silicon.
5. The applicator of claim 1, wherein the sock is translucent.
6. The applicator of claim 1, wherein the sock has a lateral cross-section that is polygonal.
7. The applicator of claim 1, wherein the sock has a symmetrical lateral cross-section.
8. The applicator of claim 1, wherein the sock includes an outer surface that is textured to engage at least one of a lash extension or an adhesive for the lash extension.
9. The applicator of claim 1, wherein the sock includes an outer surface having a plurality of projections structured to engage at least one of a lash extension or an adhesive for the lash extension.
10. The applicator of claim 1, wherein the sock includes an outer surface that is flat.
11. The applicator of claim 1, wherein the sock is flexible.
12. The applicator of claim 1, wherein the sock includes an outer surface that is non-stick.
13. The applicator of claim 1, wherein the arm includes a first outer surface having a first coefficient of friction relative to at least one of a lash extension or an adhesive for the lash extension, wherein the sock includes a second outer surface having a second coefficient of friction relative to at least one of the lash extension or the adhesive for the lash extension, wherein the second coefficient of friction is not identical to the first coefficient of friction.
14. The applicator of claim 13, wherein the second coefficient of friction is higher than the first coefficient of friction.
15. The applicator of claim 1, wherein the arm is a first arm, wherein the tip portion is a first tip portion, wherein the sock is a first sock, and further comprising:
  - a second arm having a second tip portion; and
  - a second sock mounted onto the second tip portion, wherein the first sock and the sock are structured to grasp a lash extension when the lash extension is interposed between the first sock and the second sock.
16. The applicator of claim 1, wherein the sock includes an inner channel having a lateral cross-section that is polygonal.
17. The applicator of claim 1, wherein the sock includes an inner channel having a lateral cross-section that is symmetrical.
18. The applicator of claim 1, wherein the sock includes an inner channel that is not longitudinally rectilinear.
19. The applicator of claim 18, wherein the inner channel is arcuate.
20. The applicator of claim 1, wherein the sock is removably mounted onto the tip portion.
21. The applicator of claim 1, wherein the sock has an open end portion and a closed end portion, wherein the sock is mounted onto the tip portion through the open end portion, wherein the closed end portion is at least partially closed.
22. A kit comprising:
  - a package;
  - an applicator contained in the package, wherein the applicator includes an arm having a tip portion; and
  - a sock contained in the package, wherein the sock is mountable onto the tip portion.
23. The kit of claim 22, wherein the sock is mounted onto the tip portion.
24. A method comprising:
  - mounting a sock onto a tip of an arm of an applicator; and
  - engaging a lash extension with the sock.
25. A method comprising:
  - causing a sock to be mounted onto a tip of an arm of an applicator; and
  - causing the sock to engage a lash extension.
26. An applicator comprising:
  - an arm having a tip that is externally coated with a non-stick coating.
27. The applicator of claim 26, wherein the non-stick coating includes silicon.
28. The applicator of claim 26, wherein the non-stick coating includes rubber.
29. The applicator of claim 26, wherein the non-stick coating is longitudinally rectilinear on the tip.
30. The applicator of claim 26, wherein the non-stick coating is longitudinally non-rectilinear on the tip.
31. The applicator of claim 30, wherein the non-stick coating is longitudinally arcuate on the tip.
32. The applicator of claim 26, wherein the tip includes an inner side that is externally coated with the non-stick coating.
33. The applicator of claim 26, wherein the arm includes a first outer surface having a first coefficient of friction relative to at least one of a lash extension or an adhesive for the lash extension, wherein the non-stick coating includes a second outer surface having a second coefficient of friction relative to at least one of the lash extension or the adhesive for the lash extension, wherein the second coefficient of friction is not identical to the first coefficient of friction.
34. The applicator of claim 33, wherein the second coefficient of friction is higher than the first coefficient of friction.
35. The applicator of claim 26, wherein the arm is a first arm, wherein the tip is a first tip, wherein the non-stick coating is a first non-stick coating, and further comprising:
  - a second arm having a second tip that is externally coated with a second non-stick coating, wherein the first tip and the second tip are structured to enabling grasping of a lash extension when the lash extension is interposed between the first non-stick coating and the second non-stick coating.
36. A method comprising:
  - coating an outer surface of a tip of an arm of an applicator with a non-stick coating.
37. A kit comprising:
  - a package; and
  - an applicator contained in the package, wherein the applicator includes an arm having a tip that is externally coated with a non-stick coating.
38. A pair of socks for applying artificial eyelashes onto natural eyelashes, each of the socks comprising:
  - an elongated portion that defines (i) an inner channel configured to be mounted to and retained on a tip of an applicator used to apply the artificial eyelashes onto the natural eyelashes, and (ii) a lateral portion that enables a user to grasp artificial eyelashes when squeezed together when positioned on respective tips of the applicator.

**39.** The socks according to claim **38**, wherein the elongated portions include respective inner sides that geometrically match one another.

**40.** The socks according to claim **38**, wherein the socks have non-stick surfaces.

\* \* \* \* \*