

T. A. WESTON.
 Automatic Friction-Brake and Hand-Lever Brake
 for Speed-Regulating and Braking.
 No. 217,030. Patented July 1, 1879.

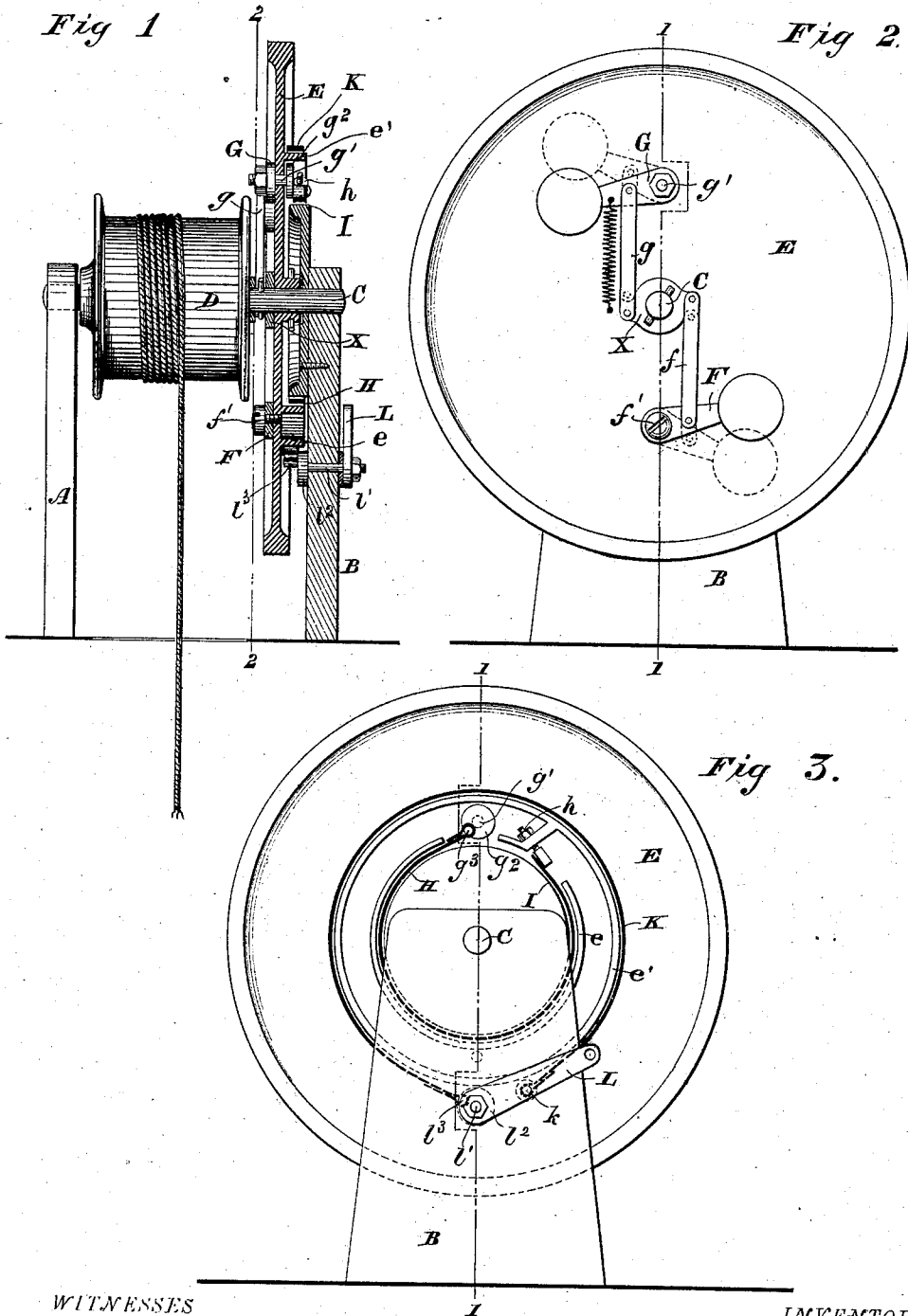

WITNESSES
Wm A Skinkle.
Robertdean Buchanan.

INVENTOR
Thomas A Weston.
 By his Attorneys
Baldwin, Hopkins, & Peyton.

UNITED STATES PATENT OFFICE.

THOMAS A. WESTON, OF STAMFORD, CONNECTICUT, ASSIGNOR TO THE YALE LOCK MANUFACTURING COMPANY, OF SAME PLACE.

IMPROVEMENT IN AUTOMATIC FRICTION-BRAKE AND HAND-LEVER BRAKE FOR SPEED-REGULATING AND BRAKING.

Specification forming part of Letters Patent No. **217,030**, dated July 1, 1879; application filed May 24, 1878; patented in England, July 9, 1878.

To all whom it may concern:

Be it known that I, THOMAS A. WESTON, of Stamford, in the county of Fairfield and State of Connecticut, have invented certain Improvements in Automatic Friction-Brakes for Machinery, of which the following is a specification.

My invention is patented in England, No. 2,739 of 1878; and it relates to that class of speed-regulators in which centrifugal force and frictional resistance are prominent elements—as, for example, in the invention of James White, civil engineer, described and illustrated in his "Century of Inventions," pp. 364 and 365, Plate 46, Fig. 2, published at Manchester, England, A. D. 1822.

The accompanying drawings represent my improvements as applied to a simple wheel and axle hoist; but they are also applicable to other mechanism in which it is desirable to limit the velocity of the shafting.

In the drawings, Figure 1 indicates a longitudinal elevation of a hoist embodying my improvements, with the speed-regulator and adjacent parts shown sectionally on the line 1 1, Figs. 2 and 3. Fig. 2 represents, in elevation, the side of the regulator-wheel nearest the winding-drum—that is, a sectional view in the line 2 2, Fig. 1. Fig. 3 represents the reverse or outer side of the regulator-wheel and the adjacent parts in end elevation.

A and B represent supports or side frames, carrying the shaft C and drum D, keyed thereon. E represents the regulator-wheel, and it may also serve as a driving-wheel for the shaft C, to which it is keyed. F and G represent centrifugal or weighted levers, placed in equilibrium with each other by the linked connection formed of the pivoted connecting-rods *f g* and intermediate lever, X, which turns freely upon the shaft C. Pins or pivots connect or joint the ends of the rods *f* and *g*, respectively, to the levers F, G, and X.

The lever F is pivoted to the wheel E by a fixed stud, *f'*. The lever G is secured to and turns with a short shaft, *g*¹, passing through the wheel E; and at its other extremity the shaft *g*¹ carries a crank-disk, *g*², the stud or crank-pin of which, *g*³, engages with the free

end of the brake-strap H. The strap H is secured at its fixed end to the wheel E by a screw-bolt and nut, *h*, for adjusting the length of the strap to the brake-pulley I. *e* represents a rim or flange formed upon the wheel E to receive the strap H when relaxed, and compel it then to take a circular form equidistant and free from the friction-surface of the pulley I. *e'* represents a circular flange cast upon the wheel E to form a brake-pulley or friction-rim for the brake-strap K, one end of which, *k*, is secured to the frame or support B. The free end of the brake-strap K embraces the crank-pin *l*³ of the crank-disk *l*² and shaft *l*¹, attached thereto. L represents a lever fixed to the shaft *l*¹ to operate it, and thereby apply the strap K to the brake-rim *e'* or withdraw it.

The operation of my invention may be thus explained: The normal position of the strap H, in which it is free of contact with the pulley I, and the corresponding position of the weighted levers F G, as shown in Fig. 2, are secured by the uncoiling tendency in the strap to straighten itself or unbend from the pulley. This tendency may be further aided or secured, where necessary, by means of spiral or other springs of adjustable tension to pull back the levers F and G to the position wherein the outer or weighted ends are as near as possible to the shaft, as shown in Fig. 2. The shaft, the regulator-wheel, and all the attached parts are then free to rotate in either direction at any velocity less than is sufficient, by centrifugal force, to swing out the levers F and G into the position of the dotted lines in Fig. 2. In the latter position the strap H is drawn into contact with the pulley I, and with a degree of force increasing with any increase of power and velocity in the wheel E. Thus between the strap H and pulley I there is obtained an amount of frictional resistance or brake action always proportionate with and determined by the rotatory force or velocity of the wheel E, which, in this manner, is self-regulated or automatically limited in its rotatory speed. In order to reduce the speed of the wheel E, due to any applied driving force, to a still lower rate than is effected automatically, the strap

K may be applied as needed to the pulley-rim *e* by depressing the lever L, and in like manner, by applying sufficient force, the wheel E may be stopped and held at rest.

In the drawings, the wheel E is represented as being driven by a winding-drum and cord, the running off of which, as in the case of a descending load, is automatically regulated in the manner described, and a self-checked lowering action, applicable to hoisting machines generally, is thereby obtained. It is obvious that any shaft, wheel, pulley, or machine, however driven, may by like means be made self-regulated in its speed of rotation.

Although I have described my invention as constructed to operate by means of balanced centrifugal weights turning upon pivots carried by the regulator-wheel, it is obvious that a single weight or lever arranged to be operated by centrifugal force would be capable, but with diminished efficiency, of exerting its force upon the brake-strap. For like reasons the number of centrifugal weights or levers need not be limited to two, for any greater number may be employed which can be conveniently located upon the governor-wheel, if each be provided with the same linked connection, uniting it with the common vibrating center or intermediate lever, X. The said common connection of the two or more weights or levers with the lever X serves to unite them in one system, so that their aggregate centrifugal force is united and applied to the brake-strap at its junction with the system.

What I claim as my invention is—

1. In an automatic speed-regulator, the combination of a rotatory regulator-wheel, a centrifugal weight or lever, a brake-strap, and its

brake-pulley, connected together upon the same wheel, substantially as described.

2. In an automatic speed-regulator, the combination of a rotatory regulator-wheel, a system of two or more connected centrifugal weights or levers, a brake-strap, and its brake-pulley, connected together upon the same wheel, substantially as described.

3. In an automatic speed-regulator, the combination of a rotatory regulator-wheel, E, a centrifugal weight or weights, the shaft g^1 , and attached crank-pin g^3 with the strap H and pulley I, substantially as described.

4. In an automatic speed-regulator provided with a regulator-wheel, E, a centrifugal weight or weights, a brake-strap, and brake-pulley, a connecting device uniting the said weight or weights to the said strap, the combination of a brake-rim, *e'*, a brake-strap, K, and its operating-lever L, substantially as described.

5. In an automatic speed-regulator provided with a regulator-wheel, E, the combination of weight or lever G, shaft g^1 and attached crank-pin g^3 , strap H and pulley I, and the rim or flange *e*, substantially as described.

6. The combination of an automatic speed-regulator, consisting of the wheel E, lever G, shaft g^1 and attached crank-pin g^3 , strap H, and pulley I, with a winding-drum and shaft, or its equivalent, substantially as described.

In testimony whereof I have hereunto subscribed my name.

THOS. A. WESTON.

Witnesses:

MARCUS S. HOPKINS,
WOODBURY LOWERY.