

H. W. SCHOFF.
 LIQUID FUEL BURNER.
 APPLICATION FILED JULY 2, 1910.

985,291.

Patented Feb. 28, 1911.

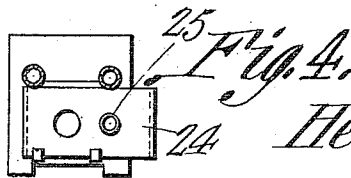
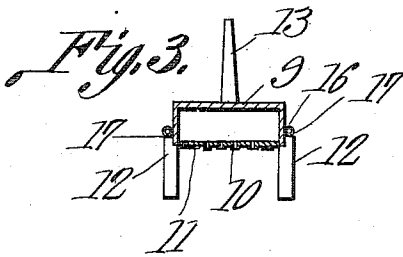
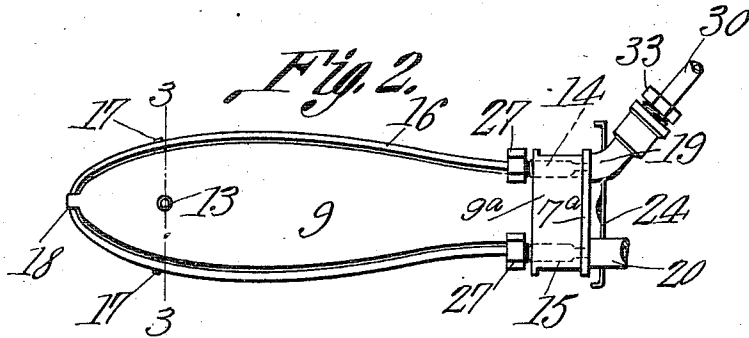
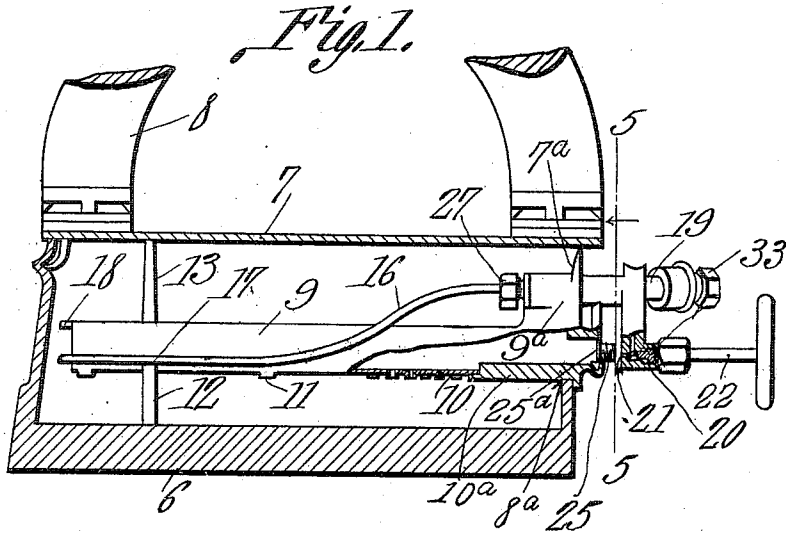

Witnesses

J. C. ...
M. A. ...

Henry W. Schoff,
 Inventor

by *C. Snow & Co.*
 Attorneys

UNITED STATES PATENT OFFICE.

HENRY W. SCHOFF, OF RIVER FOREST, ILLINOIS.

LIQUID-FUEL BURNER.

985,291.

Specification of Letters Patent. Patented Feb. 28, 1911.

Application filed July 2, 1910. Serial No. 570,111.

To all whom it may concern:

Be it known that I, HENRY W. SCHOFF, a citizen of the United States, residing at River Forest, in the county of Cook and State of Illinois, have invented a new and useful Liquid-Fuel Burner, of which the following is a specification.

This invention relates to liquid fuel burners designed more particularly for use in connection with self heating sad irons; and it is the object of the invention to provide a burner of this kind embodying certain novel features of construction to be herein described and claimed.

The invention also has for its object to provide, in connection with the burner, a vapor generating tube which can be readily removed from the burner body for cleaning and other purposes, together with an improved support for said tube.

The invention is illustrated in the accompanying drawing forming a part of this specification, in which drawing—

Figure 1 is an elevation of the burner, partly broken away, the burner being shown in position within the iron. Fig. 2 is a plan view of the burner. Fig. 3 is a transverse section on the line 3—3 of Fig. 2. Fig. 4 is a transverse section on the line 5—5 of Fig. 1.

Referring more particularly to the drawing, 6 denotes the body of the iron, the same being hollow to receive the burner. The iron body has an open top which is closed by a cover 7 provided with a handle 8.

The burner comprises a substantially oval-shaped hollow body portion 9 mounted within the interior of the iron body, and having its bottom closed by a plate provided with a large number of minute burner nipples 10 which are formed by perforating the plate in a press with the punch and die in such a manner as to form burrs around the perforations. This bottom plate is secured to the burner body by tongues 11 on the latter. The rear portion 10^a of the burner body is closed and imperforate at the bottom, and seats in a suitable opening 8^a made in the rear of the iron body. The front wall of the burner body has legs 12 on each side, whereby it is supported on the floor of the interior of the iron body. From the top of the burner body rises a stem 13 which extends upwardly far enough so as to be engaged by the cover 7 when the latter is in place. This arrangement provides a rigid

support for the front end of the burner body, and the legs effectually prevent the same from tilting sidewise. The rear portion of the burner body is raised at its top as at 9^a where it passes through the opening 8^a, and from this raised portion rises a web 7^a which extends across and closes the upper part of said opening and extends upward to and contacts with the cover 7 when the latter is in place. In the rear extremity of the raised portion 9^a of the body are fuel passages 14 and 15, respectively. To these passages, within the iron body, is connected a looped vapor generating tube 16, one end of said tube being connected to the passage 14, and the other end to the passage 15 by couplings 27. From these points forward the tube is dropped as best seen in Fig. 1, and its legs diverge and pass astride the burner body 9 in close metallic contact therewith, and thence straight forward and around its front end so that they are supported on shoulders 17 formed by the upper ends of the legs 12, located on opposite sides of the burner body. From the front end of the burner body extends a lug 18 which is located above the tube, and prevents the same from slipping upwardly.

The rear end of the burner body, on the outside of the iron body, is formed with a nipple 19 into which the passage 14 opens, said nipple being connected by a coupling 33 with a pipe 30 leading to the fuel reservoir (not shown). The rear end of the burner body, on the outside of the iron body, is also formed with a valve casing 20 with which the passage 15 communicates. This valve casing has a jet orifice 21 controlled by a needle valve 22, and located so as to discharge through an inlet opening 25^a in the burner body into the interior thereof. Across the opening works a slide 24 having two different sized openings either one of which is adapted to be brought in alinement with the jet orifice 21, the larger opening being employed when gasolene fuel is used, and the smaller opening when the fuel is alcohol. The smaller opening is formed with a nipple 25 which, when it is in operative position, extends close to the jet orifice. This nipple is employed because when alcohol is used as the liquid fuel it is not desirable that so much air be drawn in with the jet as when gasolene is used.

In operation of the burner, the liquid fuel enters the tube 16 from the passage 14, and

in passing through said tube is vaporized, the vapor thus formed entering the valve casing and being discharged through the jet orifice into the burner casing, the discharge taking place through one of the openings in the slide 24. The slide will be adjusted according to the kind of fuel used, as already described. The close contact of the generating tube with the sides of the body of the burner causes the fuel to be vaporized quickly as will be clear and yet said tube may be removed for cleaning or repair by disconnecting the couplings 27 (the entire burner being removed from the flat iron body) and slipping the tube forward so that its bent front end disengages from beneath the lug 18 when its legs can be lifted off the shoulders 17.

What is claimed is:

1. A burner comprising a hollow body with a perforated bottom and a raised rear end, the latter provided with longitudinal fuel passages, a fuel supply pipe and a valve connected with the outer ends of said passages, couplings at their inner ends, and a looped vapor generating tube whose extremities are connected with said couplings

and whose legs extend thence forward and are dropped alongside and into metallic contact with the sides of the body. 30

2. A burner comprising a hollow body with a perforated bottom and a raised rear end, the latter provided with longitudinal fuel passages, a fuel supply pipe and a valve connected with the outer ends of said passages, couplings at their inner ends, a forwardly projecting lug on the front end of the body, legs supporting said body and having upwardly facing shoulders at its sides, and a looped vapor generating tube whose extremities are connected with said couplings and whose legs extend thence forward and are dropped alongside and into metallic contact with the sides of the body and rest upon said shoulders, its bend extending around the front end of the body beneath said lug. 45

In testimony that I claim the foregoing as my own, I have hereto affixed my signature in the presence of two witnesses.

HENRY W. SCHOFF.

Witnesses:

N. S. BURGESS,
F. C. RALSTON.