

Oct. 4, 1938.

E. B. BERKOWITZ

2,132,012

TUCK FLAP ENVELOPE

Filed Sept. 9, 1935

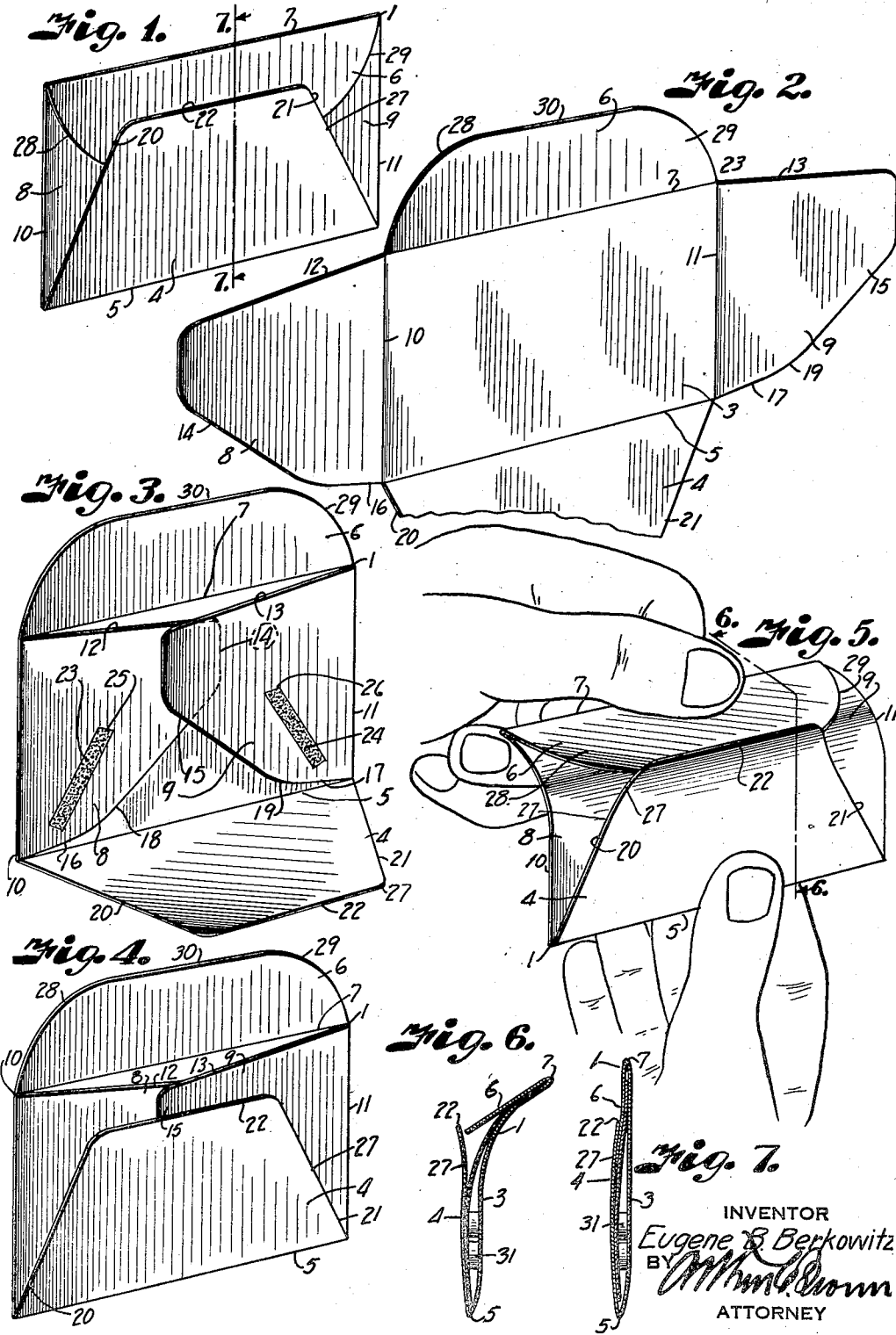

INVENTOR  
Eugene B. Berkowitz  
BY *Wm. H. Brown*  
ATTORNEY

## UNITED STATES PATENT OFFICE

2,132,012

## TUCK FLAP ENVELOPE

Eugene B. Berkowitz, Kansas City, Mo., assignor  
to Berkowitz Envelope Company, Kansas City,  
Mo., a corporation of Delaware

Application September 9, 1935, Serial No. 39,720

2 Claims. (Cl. 229—76)

This invention relates to envelopes, and particularly to those for containing tablets, pills, and sample articles of similar nature that are of hygroscopic character. When articles of this character are packaged in envelopes provided with gummed sealing flaps, moistening of the gum to seal the flaps causes disintegration of the enclosed articles. It is, therefore, the principal object of the present invention to provide an envelope of this character with a tuck closure flap, so that the articles may be securely retained therein without the use of adhesives.

It is also an important object of the invention to provide a construction which facilitates manipulation of the tuck flap.

In accomplishing these and other objects of the invention, hereinafter pointed out, I have provided improved details of structure, the preferred form of which is illustrated in the accompanying drawing wherein:

Fig. 1 is a perspective view of an envelope constructed in accordance with the present invention, showing the tuck flap in closed position.

Fig. 2 is a detail perspective view of a blank from which the envelope is formed.

Fig. 3 is a perspective view of the blank partly folded.

Fig. 4 is a similar perspective view showing the blank completely folded to form an envelope with the closure flap in an open condition.

Fig. 5 is a detail perspective view showing the method of tucking the closure under the lip of the bottom flap.

Fig. 6 is a cross-section on the line 6—6 of Fig. 5, showing the manner in which the closure flap enters between the lip of the bottom flap and the side flaps, incidental to curving of the envelope.

Fig. 7 is a section on the line 7—7 of Fig. 1, showing the closure flap in tucked position for retaining articles within the envelope.

Referring more in detail to the drawing:

1 designates an envelope constructed, in accordance with the present invention, from a blank 2, of foldable material, shaped to provide a substantially rectangular front or body portion 3, a back or bottom flap 4 extending along one side 5 of the body portion, a closure flap 6 extending along the opposite side 7, and side flaps 8 and 9 extending along the ends 10 and 11 thereof, as shown in Fig. 2.

The side flaps 8 and 9 have upper edges 12 and 13 extending at a slight angle to the side 7 of the body portion, so that when the side flaps are folded across the inner face thereof, the edges of the flaps will extend in substantially close rela-

tion thereto, as shown in Fig. 3. The ends 14 and 15 of the side flaps are of sufficient length that they overlap in the center of the body portion to form a smooth surface, over which the closure flap 6 is adapted to slide into tucked relation with the back flap, as later described.

The bottom edges of the side flaps extend outwardly from the body portion as at 16 and 17, at substantially the same angle as the upper edges, but terminate on rounded curves 18 and 19 to connect with the ends 14 and 15, as shown in Fig. 2.

The back flap has converging end edges 20 and 21 and an outer edge 22 extending parallel with the edges 5 and 7 of the body portion of the envelope. The back flap is of sufficient length that it extends beyond the vertical median line of the envelope, with the edge 22 thereof overlying the lapped portions of the side flaps but terminating short of the upper edges 12 and 13 thereof, as shown in Fig. 4.

The side flaps are provided with stripes of adhesive 23 and 24 arranged at such an angle thereon that they will sealingly engage the converging end edge portions of the back flap. The ends 25 and 26 of the adhesive stripes terminate short of the edge 22 to provide a free portion forming a lip 27, under which the closure flap 6 is tucked, as later described. The closure flap 6 has its ends rounded, as at 28 and 29, and has a parallel outer edge 30 to tuck under the lip of the bottom flap.

After the envelope is completed, as shown in Fig. 4, the closure flap may be folded to overlie the lip 27 of the bottom flap. When the envelope is to be used in packaging articles, such as tablets 31, the closure flap is raised to allow insertion of the tablets between the lapped side flaps and the body portion of the envelope.

The closure flap is then allowed to fall back into overlying relation with the side and bottom flaps, whereupon the upper edge portion of the envelope is gripped between the thumb and forefinger of one hand, and the bottom edge between the thumb and forefinger of the other hand. When in this position, the thumb and forefinger at the upper portion of the envelope grips both the closure flap and overlapped portions of the side flaps, then when the envelope is curved, as shown in Fig. 5, the lip portion of the bottom flap will curve outwardly from under the closure flap to permit the edge 30 of the closure flap to enter between the outwardly curved lip and the side flaps, as shown in Figs. 5 and 6.

Upon release of the curving pressure the envelope will assume a flattened condition, and the

lip of the bottom flap will lie flatly against the closure flap to retain it in tucked position, as shown in Figs. 1 and 7.

When the closure flap is tucked in position as shown, the tablets are retained against loss without the use of any adhesive on the closure; therefore, since no moisture is required in sealing the envelope, the tablets will remain in the same dry condition as when packed.

10 What I claim and desire to secure by Letters Patent is:

1. An envelope of the character described including a body portion formed of flexible material, side flaps overlying said body portion and having upwardly converging lower edges and upper edges extending substantially parallel with the upper edge of the body portion to provide overlapping ends, a bottom flap having less height than the body portion and overlying the side flaps with the side edges thereof converging upwardly in overlapping relation with the side flaps and sealed to said side flaps with the seals terminating substantially at points midway between the bottom and top edges of the envelope to leave an unattached lip extending across the entire width of the bottom flap and above said seal-terminating points, and a closure flap on the body portion foldable over the side flaps to underlie said lip, said closure flap being insertable between the overlapping portions of the side flaps and the lip

5 incidental to curving of the envelope in a direction parallel to said lip whereby the upper half of the envelope moves away from said lip to accommodate movement of the closure flap therebetween.

2. An envelope of the character described including a body portion formed of flexible material, side flaps overlying the body portion and having terminal portions overlapping each other and upper edges extending substantially parallel with the upper edge of the body portion, a bottom flap having less height than the body portion and overlying the side flaps and having side edges sealed to the side flaps with the seals terminating substantially at points midway between the bottom and top edges of the envelope to leave an unattached lip extending over the overlapped terminal portions of the side flaps, and a closure flap on the body portion foldable over the side flaps and of sufficient size so that the free edge thereof is adapted to be inserted between the overlapped terminal portions of the side flaps and said lip to be gripped thereby, the closure flap being insertable incidental to curving of the envelope in a direction parallel to said lip and through said sealed terminating points whereby the upper half of the envelope moves away from said lip to accommodate movement of the closure flap therebetween.

EUGENE B. BERKOWITZ. 30