



(19) **United States**

(12) **Patent Application Publication**

**Nilsson**

(10) **Pub. No.: US 2001/0011830 A1**

(43) **Pub. Date: Aug. 9, 2001**

(54) **DEVICE FOR AVOIDING WHIPLASH INJURIES**

**Publication Classification**

(76) Inventor: **Kent Nilsson, Billdal (SE)**

(51) **Int. Cl.<sup>7</sup> ..... B60N 2/02**

(52) **U.S. Cl. .... 296/68.1**

Correspondence Address:  
**One World Trade Center  
Suite 1600  
121 S.W. Salmon Street  
Portland, OR 97204 (US)**

(57) **ABSTRACT**

(21) Appl. No.: **09/811,012**

(22) Filed: **Mar. 15, 2001**

**Related U.S. Application Data**

(63) Continuation-in-part of application No. 09/380,715, filed on Sep. 3, 1999, which is a 371 of international application No. PCT/SE98/00435, filed on Mar. 11, 1998.

(30) **Foreign Application Priority Data**

Mar. 11, 1997 (SE)..... 9700907-0  
Jan. 14, 1998 (SE)..... 9800054-0

An apparatus that reduces the acceleration to which the body is subjected after the incidence of the collision to less than 4 g, since it has been found that whiplash injuries occur in collisions exceeding 5 g. In one embodiment, a device and a method intended to counteract the occurrence of whiplash injury to a person sitting in a seat, which could occur through a rapid change in velocity, such as in a collision essentially from the rear. The arrangement contains means whereby the seat will move in a controlled manner against the direction of movement during a change in velocity, and that the seat is provided with guide means, which are designed to give the seat and the person sitting in it a controlled inclined an essentially simultaneous backward movement, in which the head of the occupant sitting on the seat is accelerating under a longer distance compared with the occupants hip close to the seat, and that the seat is arranged so that it will remain in its rearward position after the change in velocity.

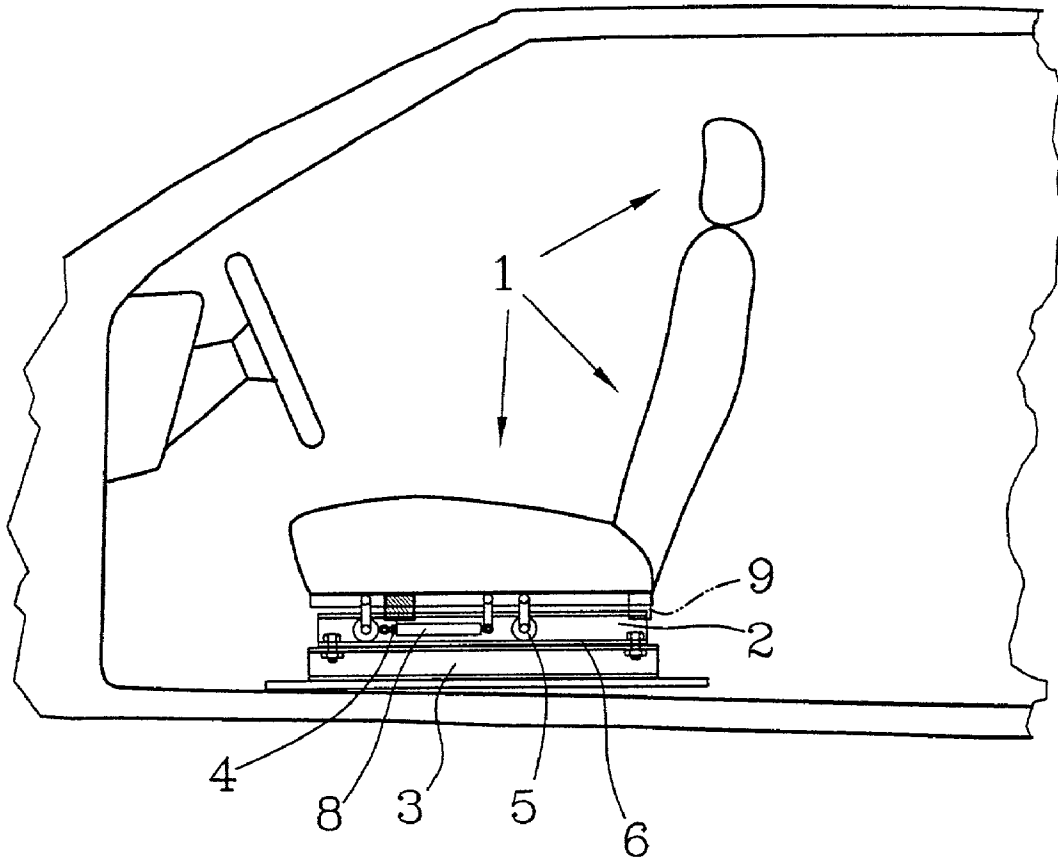

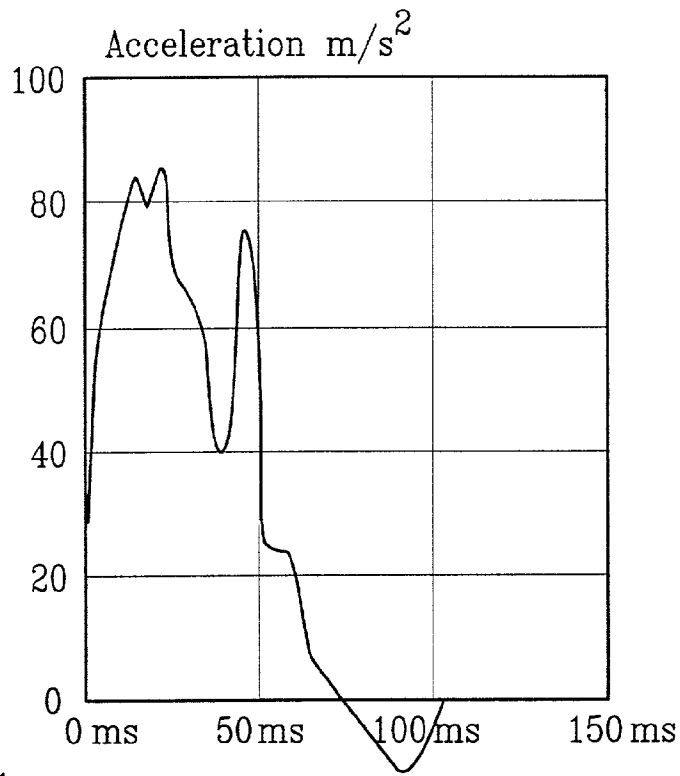

FIG. 1

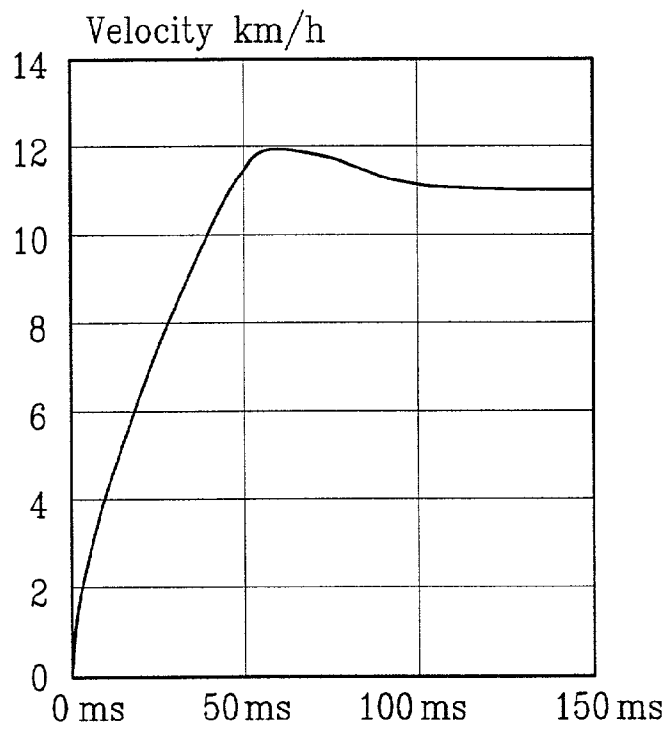

FIG. 2

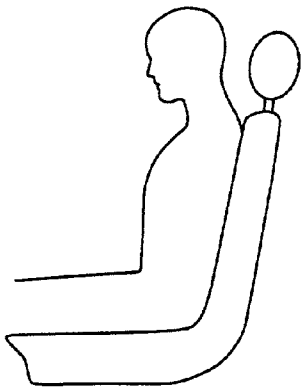

FIG. 3

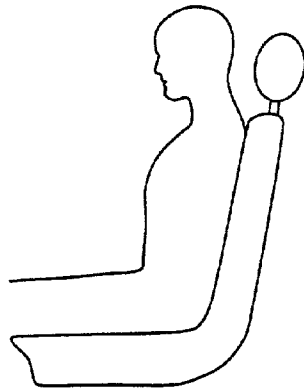

FIG. 4

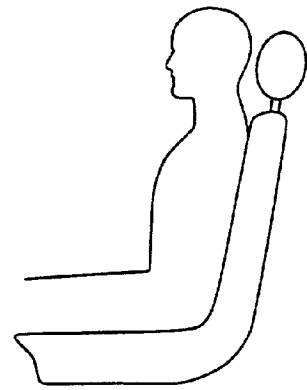

FIG. 5

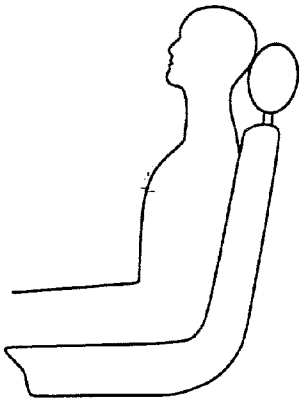

FIG. 6

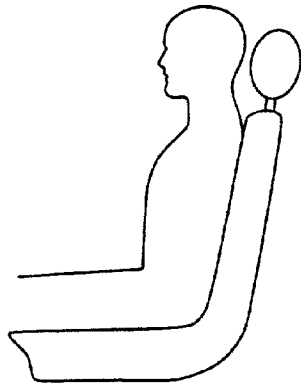

FIG. 7

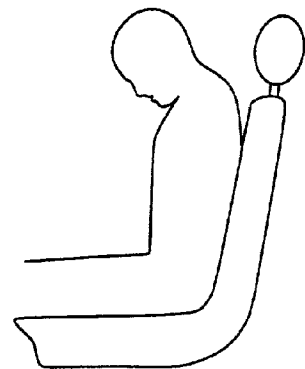

FIG. 8

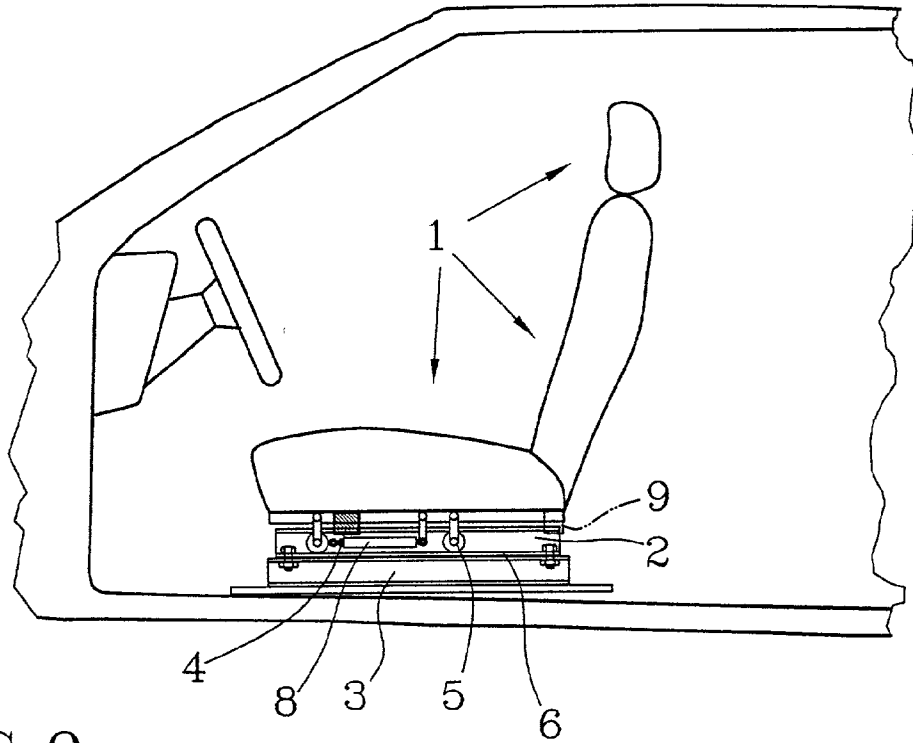

FIG. 9

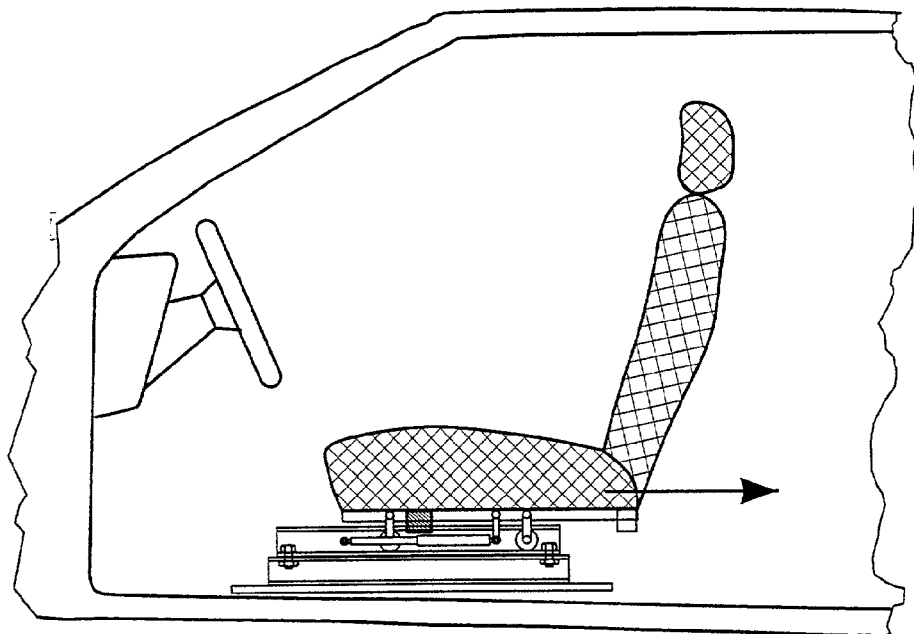

FIG. 10

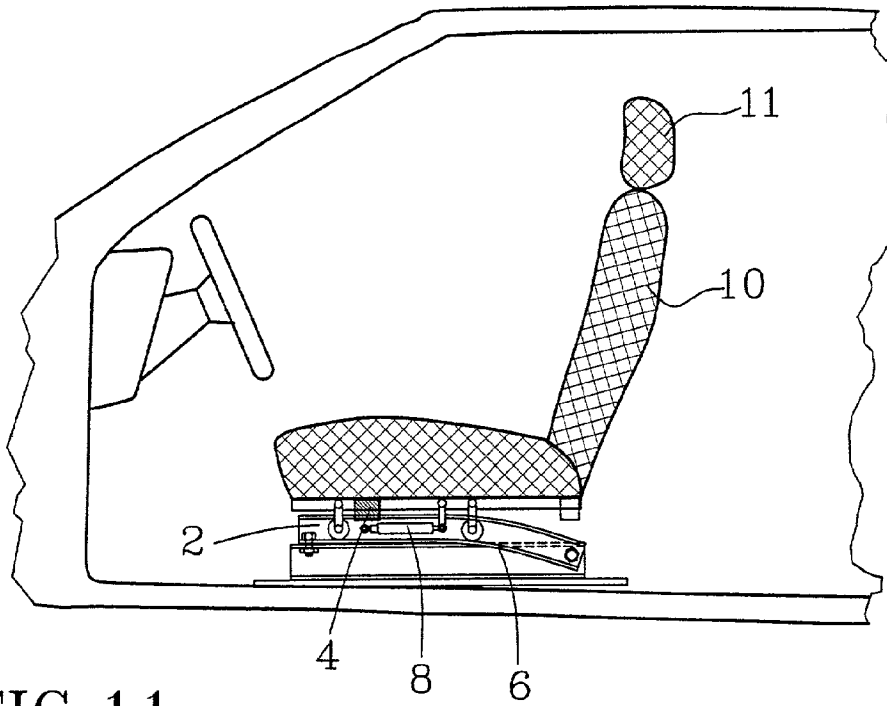

FIG. 11

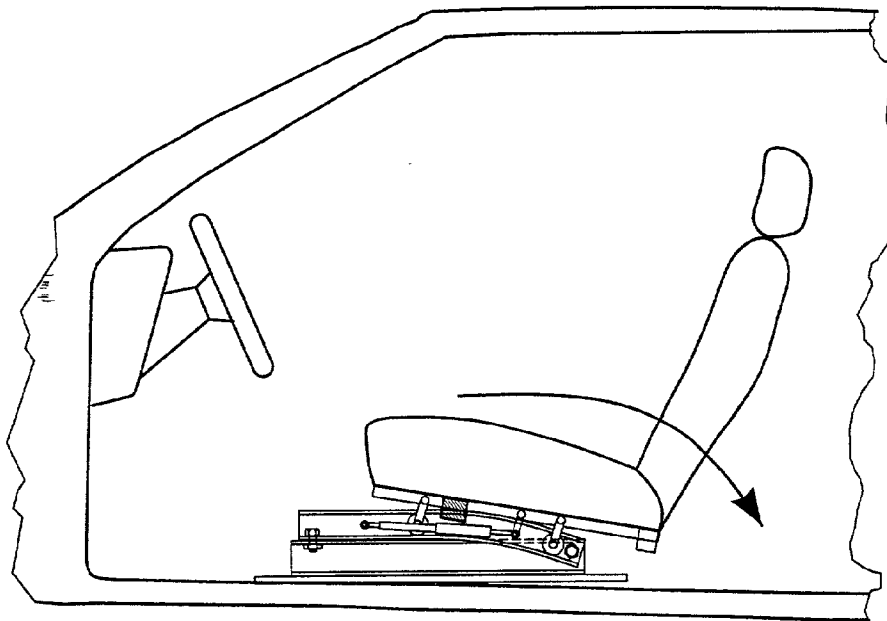

FIG. 12

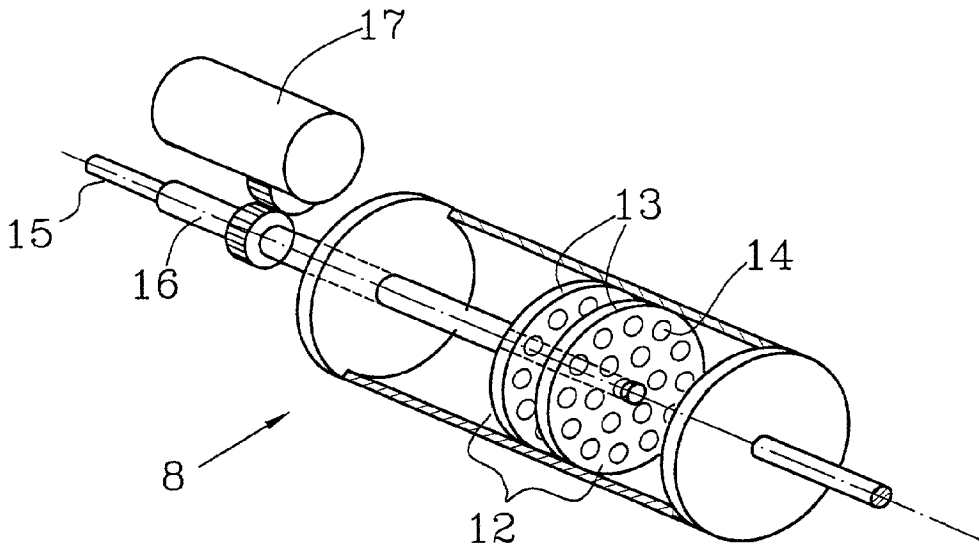

FIG. 13

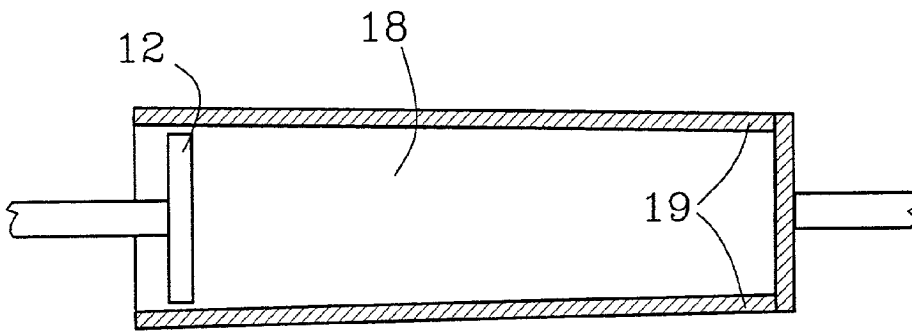

FIG. 14

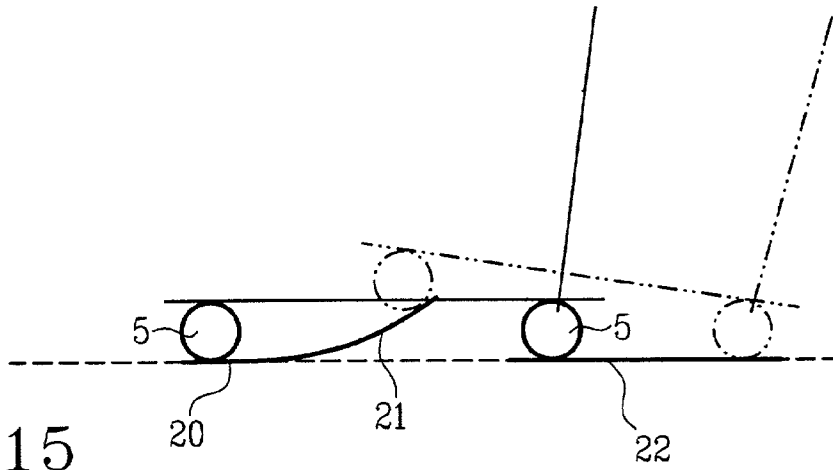

FIG. 15

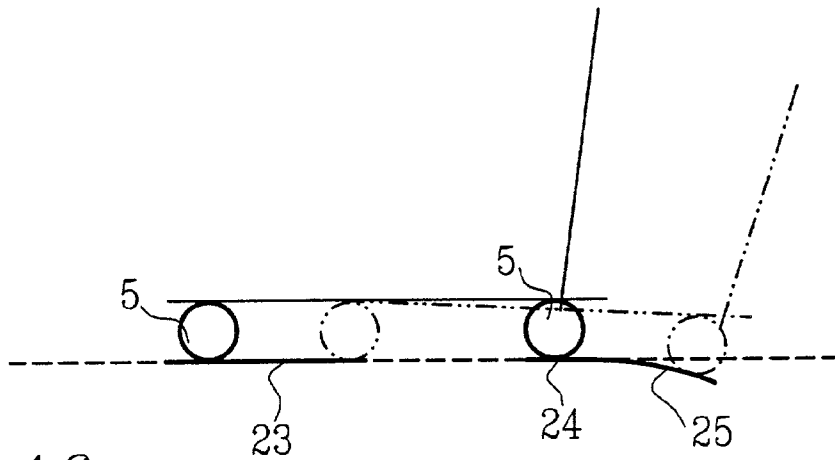

FIG. 16

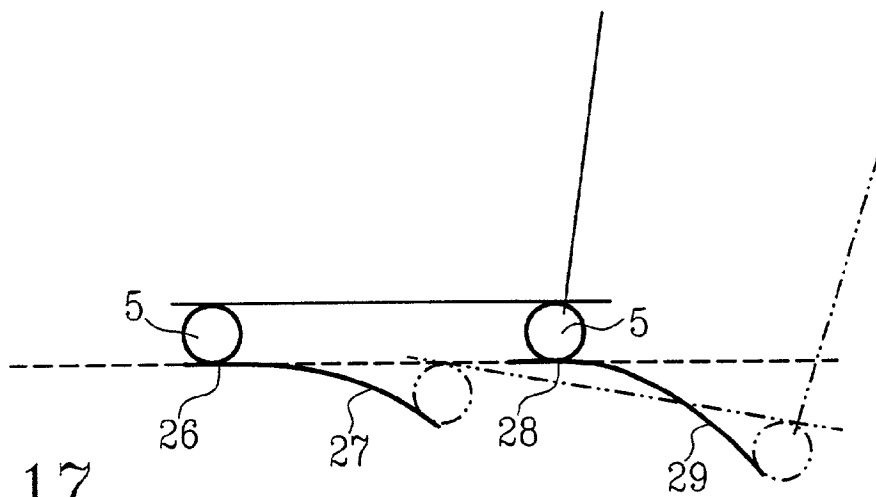

FIG. 17

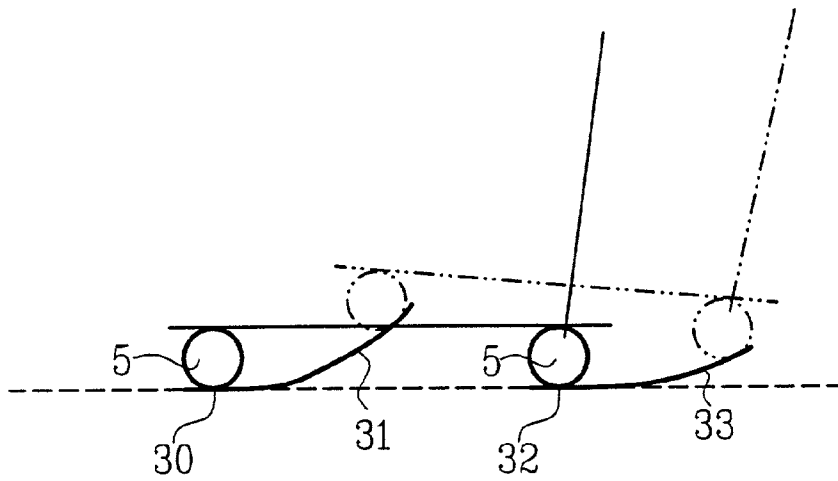

FIG. 18

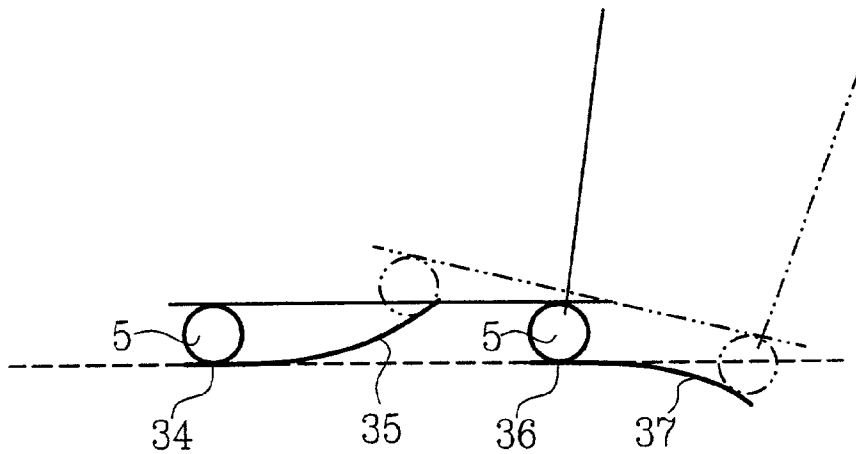

FIG. 19

**DEVICE FOR AVOIDING WHIPLASH INJURIES****RELATED APPLICATION DATA**

[0001] This application claims priority to U.S. patent application Ser. No. 09/380,715, filed Sep. 3, 1999, which claims priority to PCT/SE98/00435 filed Mar. 11, 1998, which claims priority to Swedish patent applications 9700907-0 filed Mar. 11, 1997 and 9800054-0 filed Jan. 14, 1998.

**TECHNICAL AREA**

[0002] This invention refers to a device for counteracting injury to a person sitting in a seat in a vehicle, primarily a so called whiplash injury, which can occur due to a rapid change in velocity, such as a collision, from the rear.

**BACKGROUND OF THE INVENTION**

[0003] A whiplash injury is a soft tissue injury which can occur on account of violent acceleration and/or deceleration applied to the cervical spine. The classic case where these kinds of neck injuries occur is when sitting in a car which is subjected to a rear-end impact, but can also occur in other activities than car driving, such as in participating in certain sports.

[0004] According to demands from insurance companies, 16,000 claims are sent to the insurance companies every year because of rear-end impacts in Sweden alone. Of these cases, 1,500-2,000 sustain permanent injury and 100-200 have to be given a disability pension. Whiplash injury is the most common type of injury resulting in compensation from the insurance companies. When head restraints, popularly termed head rests, became standard in cars, there were considerable hopes that whiplash injuries would disappear. The disappointing result was that the risk of permanent injury only fell by less than 20%, which shows that the problem largely remains.

[0005] Several researchers agree that the following factors and situations are of decisive importance for the question of whether a collision will cause whiplash injury or not:

[0006] (a) The distance between the head and the head restraint, and the vertical location of the head restraint.

[0007] (b) The magnitude of the collision, the crash pulse.

[0008] (c) The stiffness of the car. A stiff car gives greater acceleration, and thus higher forces.

[0009] (d) The angle of the backrest

[0010] (e) The muscular strength of the individual, in combination with the length of the cervical spine.

[0011] (f) If the person is prepared, and tensions his neck muscles back against the head restraint before the collision, the risk of whiplash injury is minimal.

[0012] (g) Small children who travel in rearward-facing child seats are subjected to the same or greater forces in a front-end crash than adults who are subjected to a rear-end collision. Despite this, children seldom suffer from neck injury in a front-end collision. Children very seldom sustain whiplash injuries.

[0013] (h) Women are subjected to about a 50% greater risk than men of suffering whiplash injury in a rear-end collision. Statistics from the same type of car.

[0014] (i) It has been found that the injury frequency is lower in older cars, where the seat backrest collapses in a rear-end collision, compared with newer cars with stronger seats (VTI).

[0015] (j) People in the back seat are only subject to half the risk of sustaining neck injuries compared with people in the front seat. This is despite the fact that head restraints are frequently not provided for the rear seats.

[0016] (k) "Bouncy" seats entail a greater risk of whiplash injury.

[0017] (l) About 25% of all whiplash injuries occur in front-end collisions.

[0018] (m) Passengers in a 4-door vehicle have a 20% higher incidence of whiplash injury compared to passengers in a car which is identical, except that it only has 2 doors. The only difference is that on the 2-door car, the B pillars are located 270 mm further back, compared with the 4-door model. This affects the position of the upper seat belt anchorage.

[0019] The last five points indicate that the risk of sustaining a whiplash injury are greatest when the head is thrown forwards as far as it will go (hyperflexion), which occurs after about 400 ms. Regardless of when the injury occurs, the risk is considerably reduced if the acceleration of the seat is minimized.

[0020] In recent years, research in this area has been intensified, which has led to new theories and experience related to the cause of whiplash injury. Several theories and initiatives have been found to be incorrect and have therefore now been rejected. This means now that there are old technical solutions which do not solve the problem.

[0021] Since the person sits completely still at the start of the crash sequence, the solution should be based on a system or device which reduces the acceleration to less than 4 g, since it has been found that whiplash injury is avoided at accelerations below 4 g. This has been demonstrated in experiments on volunteers (please refer to "Comparison of head-neck kinematics during rear-end impact between standard Hybrid III RID neck, volunteers and pmtos"). By allowing the entire seat to move backwards on a sledge-like element in the car during the instant of collision, the acceleration can be reduced to less than 4 g. Through lower acceleration, lower forces are experienced, which lead to a strongly reduced risk of injury.

[0022] In crash tests performed by the Volvo Car Corporation (Volvo Technology Report on. 2,1996), acceleration and velocity values in a typical rear-end collision were found to have the values shown in diagrams 1 and 2.

[0023] FIGS. 3-8 show the crash sequence in the first 400 milliseconds, where FIG. 3 shows the crash sequence at time 0 milliseconds (ms), where the person is in the initial position and is thus not affected by any acceleration due to collision etc. FIG. 4 shows the crash sequence at a time of 50 ms, when the acceleration has reached its peak after only 10 ms. The speed of the car increases more or less linearly and has reached its top speed after about 50 ms on account

of the collision. The body initially moves straight backwards without any mutual displacement of members. At 50 ms, the person's neck muscles begin to tense in a reflex action to counteract the rearward movement of the person's head. This is regarded as being a decisive factor when the sequence is studied. All studies involving acceleration greater than 5 g have been done on dummies, cadavers etc. **FIG. 5** shows the crash sequence at a time of about 100 ms, when the relative movement begins. The shoulders stop and the head and lower body continue to move backwards. This has been proven by researchers at the Chalmers University of Technology and others. They found that this is because the backrest is stiffer at the top, due to the cross beam in the backrest frame which unites the right and left sides of the backrest. At the same time, the mass of the body is greater in the pelvic area than in the shoulder area. There are theories that whiplash injury is caused by this effect, due to the rapid increase in pressure in the cervical spinal canal, which occurs when the head moves backwards and the volume of the cervical spinal canal decreases in a very short space of time due to the extension. This leads to an increase in pressure in the cervical spinal canal which can cause bleeding in the blood vessels around the spinal canal (myelorrhagia). Experiments have been performed on pigs at Chalmers University of Technology, in which the increase in pressure in the cervical spinal canal due to forced rapid extension was measured. Another probable source of injury would be the damage caused by the shear stress in the neck, which occurs when the head wants to move back relative to the shoulders. This effect is similar to a pack of cards lying on a table when you move the upper part of the pack sideways. The cards illustrate the disks in the cervical spine. Between 100-200 ms, the neck muscles have reached their maximum force in trying to stop the rearward movement of the head. This muscle force represents a bending moment equivalent to a force of up to 300 N at eye height. **FIG. 6** shows the crash sequence at 200 ms when the head has moved back as far as it goes, relative to the backrest and head restraint. The neck muscles are still at maximum tension. The backrest and head restraint are bent back to a maximum, and like a big spring, they will soon throw the head and torso forwards with great force. **FIG. 7** shows the crash sequence at 300 ms, when the head has about twice the speed of the car and seat. The neck muscles are still at maximum tension, which means that the acceleration of the head continues. It is probable that the head reaches nearly three times the speed of the car and seat when the backrest is "bouncy". This is because the backrest and neck muscles interact in an unfortunate manner. **FIG. 8** shows the crash sequence at about 400 ms, when the head reaches its normal stopping point. The torso suddenly stops when it meets the stiff seat belt. At this time, the head continues forwards, with considerable over-extension. Several facts indicate that it is here that the whiplash injury occurs. This would explain the whiplash injuries which occur in front-end collisions and would also explain why the incidence of whiplash injury in a 4-door vehicle is higher than in a 2-door, during a rear-end impact.

**[0024]** From this reasoning follows the thesis that it is very important to reduce the acceleration and thus to reduce the forces in a rear-end car collision. One way to do this is to allow the entire seat to move backwards in the car, in a controlled and damped movement, where the seat remains in a rearward position.

**[0025]** One known solution is described in WO 96/16834 (Rasenberg), which is mainly based on backrest movement. The solution lacks a triggering device, whose purpose is to release the rearward movement. This gives the seat a purely linear movement, which would appear to be parallel with the floor of the car, and is only intended to delay the time until the occupant's head contacts the head restraint. It can primarily be described as a spring which gives a forward and rearward movement. Dampers and plasticizing solutions are described, however. No linear-arcuate movement or trajectory are described. The entire solution is based on the assumption that the occupant's back, neck and head are not supported and will be subjected to a considerable impact with a certain delay, because of the force against the backrest, which could cause a whiplash injury. The occupant and the seat are initially at rest, with no other forces acting upon them than gravity. When the floor of the car suddenly begins to accelerate, the back and backrest are carried along as well. The known device do not have the same assumption about the fundamental reasons for why whiplash injury occurs as my invention. This means that the solution presented in this paper is intended to solve a problem which is not foreseen in this invention.

**[0026]** The device in U.S. Pat. No. 3,992,046 (Braess) is intended to reduce injury in a front-end collision, and is largely based on linear movement in parallel with the floor of the car. This device solve problems with front-end collisions and not rear-end collisions.

**[0027]** The device in WO 93/01950 (Gordon et al.) is also only intended to reduce injury in front-end collisions. The invention lacks a triggering device and is based on a seat track which differs from the present invention. In addition, the device does not remain in its triggered position after it has been triggered.

**[0028]** Further, U.S. Pat. No. 2,227,717 (Jones) describes a chair mounting for airplanes which saves the occupant from the full force of a front-end collision.

**[0029]** U.S. Pat. No. 3,802,737 (Mertens) is teaching a totally different technical solution. In that solution, the head restraint has a higher acceleration than the floor. The present invention is based on the opposite principle, i.e. it reduces the acceleration of the head restraint. The known device is mainly based on deformable sections in the backrest. In that solution, the head restraint is moved backwards and upwards in the car. In the present invention the movement is backwards and downwards, or movement backwards at the same time as the front of the seat moves upwards.

**[0030]** U.S. Pat. No. 5,022,707 (Beauvais et al.) disclose a safety device designed to respond to a sudden stopping of a vehicle, such as from a front-end collision by controlling movement of both the front-end and the rear-end of the seat. In FIGS. 25-30 Beauvais also disclose an embodiment if the vehicle is hit from the rear in a forward direction such as from a rear-end collision. In this case the rear-end of the seat rise at a greater rate than the front-end resulting in a forward inclination of the seat.

**[0031]** U.S. Pat. No. 3,578,376 (Hasegawa) is describing a common problem to absorb energy, when an impact in the forward direction is applied to the seat by a rear-end collision. The seat is capable of making a linear, backward movement along guide means to an end-stop, where the seat

is making a pivotal movement about an axis at the rear end of the seat. At the same time, an energy absorbing member is plastically deformed to reduce the impact applied to the passengers riding in the seat. Even if Hasegawa would have described simultaneous movements, the movements would be performed without control, i.e. translation and rotation occur independent of each other.

[0032] The above description of previously known technology gives a collection of inventions which to some extent all refer to injuries sustained in collisions. Another major and important difference consists of the problems which these inventions are intended to solve. In this connection, it is important to point out that one consequence of intensified research in this field is increased knowledge about whiplash injuries and their origins, which has led to and constantly leads to new problem formulations and deeper nuances of old problem formulations. This means that there are considerable differences between current problem formulations and old ones.

#### SUMMARY

[0033] The fact that the mechanisms of the car, the seat and the head restraint all interact with the neck muscles is a phenomenon which has not previously been studied in depth. Almost all studies involving acceleration greater than 5 g have been done on dummies or cadavers, which is obviously a limitation in this area. New results indicate, as noted above, that it is the interaction between the occupant and the seat which cause whiplash injuries. The main purpose of the invention is to reduce the acceleration to which the body is subjected after the incidence of the collision to less than 4 g, since it has been found that whiplash injuries occur in collisions exceeding 5 g.

[0034] These new findings, combined with this invention, will lead to fewer injuries. The purpose of this invention is achieved through a device and a method intended to counteract the occurrence of whiplash injury to a person sitting in a seat, which could occur through a rapid change in velocity, such as in a collision essentially from the rear. The characteristics of this invention are that the arrangement contains means whereby the seat will move in a controlled manner against the direction of movement during a change in velocity, and that the seat is provided with guide means, which are designed to give the seat and the person sitting in it a controlled inclined an essentially simultaneous backward movement, in which the head of the occupant sitting on the seat is accelerating under a longer distance compared with the occupants hip close to the seat, and that the seat is arranged so that it will remain in its rearward position after the change in velocity.

[0035] The acceleration of the neck of the occupant decreases if the distance that the backrest of the seat can move backwards in the car increases. However, the available distance behind the seat can be very limited due to e.g. the knees of a rear-seat passenger and in a car without rear-seat the distance is generally small. By combining the translation backwards with a rotational movement it is possible to further increase the distance that the backrest can move and the acceleration of the neck of the occupant can therefore be decreased even more without the backrest hitting e.g. a rear-seat passenger.

[0036] These purposes have been solved in this invention, by means of the characteristics described in the patent claims.

#### DESCRIPTION OF THE DRAWINGS

[0037] The invention will be described below with reference to the preferred embodiments shown in the attached drawings.

[0038] FIGS. 1 and 2 show the values of acceleration and velocity during a typical rear-impact collision.

[0039] FIGS. 3-8 show the crash sequence during the first 400 milliseconds,

[0040] FIG. 9 shows an embodiment of a device, in untriggered position.

[0041] FIG. 10 shows the same device as in FIG. 1, but in the triggered position.

[0042] FIG. 11 shows an alternative embodiment, in untriggered position.

[0043] FIG. 12 shows a preferred embodiment of the same device as in FIG. 11, but in the triggered position.

[0044] FIG. 13 shows how an energy absorber with adjustable damping effect can be constructed by means of two disks provided with holes.

[0045] FIG. 14 shows a preferred embodiment of how an energy absorber with adjustable damping can be constructed by means of a tapering space for the damping piston.

[0046] FIGS. 15-19 show preferred embodiments of different variants of the way in which the tracks can be designed to give the seat a rearward motion and at the same time a rearward inclination.

#### DETAILED DESCRIPTION

[0047] The embodiments in FIGS. 9-12 illustrate implementations in the motor vehicle field, more specifically in a passenger car. It should be noted that the invention is also intended for use in buses etc. although the description primarily refers to the use of the invention in passenger cars. The concept of "against the direction of travel" refers to the direction in which the car normally moves, when it reverses. The embodiment in FIG. 9 shows a device intended to reduce injury, mainly the so-called whiplash injuries referred to in the description of the invention, sustained by a person sitting in seat 1, which could be caused by a sudden change in velocity, such as in a collision essentially from the rear or similar. Its technical composition contains means which permit controlled movement of the entire seat 1, during a change in velocity, against the direction of travel and upwards or downwards. Seat 1 is provided with guide means, which is arranged to give the seat and its occupant an essentially simultaneous and essentially backward movement against the direction of movement and/or an essentially arcuate movement.

[0048] The purpose of the arcuate movement is to arrange the seat in a position which is associated with a lower risk of sustaining whiplash injury. The characteristic of this position is that the seat takes up an inclined position such that the rearward inclination of seat 1 is greater than the inclination of the seat in the normal case. The arcuate

movement which results from the leaning position can be achieved by a number of different means.

[0049] In general, at the end of the movement, the rear of the seat is closer to the floor of the car in relation to the front of the car. It is the relative movement in height between the front section and the rear section of the seat which provides this effect. The movement can be implemented in a number of different ways:

[0050] (a) The front end of the seat moves upward at the same time as the entire seat moves backward in the horizontal direction.

[0051] (b) The rear end of the seat moves downward at the same time as the entire seat moves backward in the horizontal direction.

[0052] (c) Both the front end and the rear end of the seat move downward, but the rear end moves down more than the front end, at the same time as the entire seat moves backward in the horizontal direction.

[0053] (d) Both the front end and the rear end of the seat move upward, but the front end moves up more than the rear end at the same time as the entire seat moves backward in the horizontal direction.

[0054] (e) The front end of the seat moves upward at the same time as the rear end of the seat moves downward, at the same time as the entire seat moves backward in the horizontal direction.

[0055] Downward refers to a direction aligned essentially at right angles towards the floor of the vehicle. Upward refers to the opposite direction.

[0056] The desired inclination of the seat can be achieved by a number of solutions. One way is to design an arcuate section, such as part of an arc of constant or varying radius. This section can be connected to an essentially straight segment. The preferred embodiment has been implemented as an intermediate section 2, fixed between the ordinary attachments 3 of the seat 1 on the floor of the car. The seat 1 cannot move backward and upward/downward until a triggering device 4 has tripped. The backward movement is facilitated by fixing a rolling or sleighing device 5, such as wheels or runners, to seat 1 and allowing these to move along one or several tracks 6 in the preferred embodiment. It should be noted that neither intermediate section 2 nor tracks 6 necessarily have to be made in one piece, they could very well consist of four sections, for example, each containing one rolling device, whose extent and size are such that each rolling device can move in such a way that the purpose of the invention is achieved.

[0057] Since the rearward inclination of the seat after the device has triggered is of central importance to the invention, a description of how this can be technically achieved is attached. FIGS. 15-19 contain schematic diagrams illustrating in solid lines the seat in untriggered position and with dash and dot lines in triggered position, and the position of the rolling device 5 in relation to the track 6. The front end of the seat is on the left in the figures. It should be noted that all figures show a horizontal orientation of track 6, seen from the movement of rolling device 5. It is not necessary for the track to consist of single elements, it can consist of two or more linear or curved track elements whose purpose is to support rolling device 5 when it moves, as shown in the

figure. FIG. 15 illustrates how the front section of the track shows an essentially horizontal segment 20, attached to a segment 21 which is bent upwards and a rear track section with an essentially horizontal segment 22.

[0058] FIG. 16 illustrates how the front section of the track shows an essentially horizontal segment 23 and a rear track section with an essentially horizontal segment 24, attached to a segment 25 which is bent obliquely downward.

[0059] FIG. 17 illustrates how the front section of the track shows an essentially horizontal segment 26 attached to a segment 27 which is bent obliquely downward and a rear track section with an essentially horizontal segment 28, attached to a segment 29 which is bent obliquely downward. The difference between segments 27, 29 which are bent downward, is that the rear one 29 is bent downward more than the front one 27.

[0060] FIG. 18 illustrates how the front section of the track shows an essentially horizontal segment 30 attached to a segment 31 which is bent obliquely upward and a rear track section with an essentially horizontal segment 32, attached to a segment 33 which is bent obliquely upward. The difference between segments 31, 33 which are bent upward, is that the front one 31 is bent upward more than the rear one 33.

[0061] FIG. 19 illustrates how the front section of the track shows an essentially horizontal segment 34, attached to a segment 35 which is bent obliquely upward, and a rear track section with an essentially horizontal segment 36, attached to a segment 37 which is bent obliquely downward.

[0062] The use of these track configurations will lead to seat 1 taking up a more rearward-inclined position after the device has triggered than before it has triggered. It should be noted that the essentially horizontal segment in FIGS. 15-19 can be omitted to allow seat 1 to begin to move upward/downward at once when the device has triggered, which also leads to rearward movement. In addition, it is possible to give the essentially horizontal segment a certain inclination. One purpose of the essentially horizontal segments is to brake the seat during the time that seat 1 is moved. Braking will cause the head of the occupant to come into contact with the head restraint, which will catch up the head and give it support during continued movement of seat 1 upward or downward, depending on the track configuration chosen as above.

[0063] The trigger mechanism 4 can be of a previously known type. It can be triggered by force, acceleration etc. During movement of seat 1 backward and upward/downward, the movement is damped so that the occupant of seat 1 is not subjected to the same change of velocity to which the car or bus is otherwise subjected. At the end of the rearward movement, the seat thus takes up a position which is more rearwardly inclined than was the case before the seat 1 was triggered.

[0064] Seat 1 is designed to remain in the rearward position after the change of velocity. However, slight forward motion due to the seat backrest springing back from a state of elastic deformation is not prevented.

[0065] Damping of the movement is achieved by means of one or several energy absorbers, such as one or several traditional shock absorbers 8 or one or several dampers

whose damping effect is a function of acceleration or movement. An alternative way of implementing an energy absorber could be to use assemblies containing plasticizing elements, which plasticize on triggering. FIG. 4 shows seat 1 after the triggering device 4 has triggered and the seat 1 has been moved rearward.

[0066] An analysis of the design of this seat is given by reference to the two examples given below, please refer to FIGS. 1 and 2, where a, v, t, F, m and s correspond to units of acceleration, velocity, time, force, mass and distance respectively.

[0067] A first example demonstrating the capacity of the present invention to reduce the acceleration of a seat contained within a vehicle acted upon by an external force is as follows. Where  $a=v/t$ ,  $v=11$  km/h=3.06 m/s, and  $t=0.05$  s,  $a=(3.06$  m/s)/(0.05 s)=61 m/S<sup>2</sup>. Hence, a body which is accelerated from rest to a velocity of 11 km/h in 0.05 seconds is exposed to an acceleration of 61 m/S<sup>2</sup>. Assuming constant acceleration where  $v_{avg}=(v_{initial}+v_{final})/2$ , the distance the body travels during this time is given by the relationship, if  $v_{initial}=0$ , we will have  $v_{avg}=v_{final}/2$ ;  $s=(v_{final}*t)/2=[(3.06$  m/s)/2]\*0.05 s=0.0765 m. Hence, a body which is accelerated from rest to 61 m/S<sup>2</sup> to a velocity of 11 km/h travels a distance of 0.0765 m in 0.05 seconds. If the present invention moves the seat backward 90 mm (0.09 m) during the rear-end impact, the acceleration will occur over a total distance equivalent to 0.0765 m+0.09 m=0.1665 m. Similarly, the time over which the acceleration will occur is extended as determined by  $t=s/v_{avg}$ , if  $v_{initial}=0$ , we will have  $t=s/(v_{final}/2)=0.1665$  m/[(3.06 m/s)/2]=0.1085 seconds. The extended distance and time over which acceleration occurs corresponds to an acceleration calculated as  $a=v/t=(3.06$  m/s)/0.1085 s=28 m/s<sup>2</sup>. Hence, the present invention reduces acceleration from 61 m/s<sup>2</sup> to 28 m/S<sup>2</sup>, i.e. by 54%. As a result, a person sitting in the seat is subjected to 54% less force during the rear-end impact.

[0068] A second example demonstrating the capacity of the present invention to reduce the acceleration of a seat contained within a vehicle acted upon by an external force from 10 g to 4 g is as follows. In a relatively heavy collision, velocity increases from 0 km/h to 18 km/h in 50 ms. Where  $a=v/t$ ,  $v=18$  km/h=5 m/s, and  $t=0.05$  s,  $a=(5$  m/s)/(0.05 s)=100 m/s<sup>2</sup>. Hence, a body which is accelerated from rest to a velocity of 18 km/h in 0.05 seconds is exposed to an acceleration of 100 m/s<sup>2</sup> or approximately 10 g's. Assuming constant acceleration where  $v_{avg}=(v_{initial}+v_{final})/2$ , the distance the body travels during this time is given by the relationship. If  $v_{initial}=0$ , we will have  $s=(v_{final}*t)/2=[(5$  m/s)/2]\*0.05 s=0.125 m. Hence, a body which is accelerated from rest at 100 m/s<sup>2</sup> to a velocity of 18 km/h travels a distance of 0.125 m in 0.05 seconds. If acceleration is limited to 4 g's=39.2 m/s<sup>2</sup>, the time to reach a velocity of 5 m/s is given by  $t=a/v=(5$  m/s)/(39.2 m/s<sup>2</sup>)=0.127 seconds. Similarly, the distance travelled to reach a velocity of 5 m/s at an acceleration of 39.2 m/s<sup>2</sup> is given. If  $v_{initial}=0$ , we will have  $s=(v_{final}*t)/2=[(5$  m/s)/2]\*0.127 s=0.32 m. The seat movement required to reduce acceleration of the seat from 10 g's to 4 g's is equal to the difference between the 4 g and 10 g deceleration distances, or 0.32-0.125 m=0.195 m.

[0069] If the seat moves back 195 mm, the acceleration is reduced from 10 g to 4 g. If the seat moves a shorter distance in an initially linear movement which is then transformed

into a circular movement, this means that the head restraint moves 195 mm, the same effect is obtained at the same time as the risk of hitting one of the rear seat passengers is reduced. The controlled change of position of the entire seat 1 during a change of velocity is arranged to be limited to 20-400 mm, i.e. the least change of movement in one application can be 20 mm and the greatest change in another implementation can be 400 mm.

[0070] A sensor 9 is arranged to detect the position of an impeding person etc. behind the seat 1 in question. The sensor 9 can be of the IR type or of any other suitable type. Its purpose is to limit or check the change in position. If a person is sitting behind the relevant seat 1 when a collision occurs, this person will be subjected to a risk of injury by the rearward-moving seat 1, so it is important to be able to limit the rearward movement to reduce the risk of injury. It is also conceivable that the rearward movement could be completely prevented.

[0071] The preferred embodiment shown in FIG. 11 also illustrates an application in the automotive field. This example shows considerable similarities to the previous example, so only the differences between them will be described. In this example, track 6 in intermediate section 2 is not essentially completely straight as in the example above, it is also curved. Track 6 in intermediate section 2 can comprise one or several track segments, including one or more arc sections with constant or varying radius which give the desired shape of track 6.

[0072] The effect of the curved track 6 is to give seat 1 an inclination in its rearward position, as shown in FIG. 12. This means that an inclination is given to seat 1 and other sections such as backrest 10, head restraint 11 etc. This embodiment can be modified by using a number of different tracks instead of a single track.

[0073] This embodiment and the previous embodiment can also be designed so that seat 1 together with the device in the preferred embodiment moves backward after triggering. It should be pointed out that intermediate section 2 can be made thinner than shown in FIGS. 9, 10, 11 and 12. This means that the drawings are to be regarded as being principle sketches.

[0074] An example of another energy absorber is shown in FIG. 13. The damping function of the energy absorber 8 can also be arranged to vary according to the force/acceleration measured by such means as an accelerometer, which could be contained in the triggering mechanism 4 and which indicates the magnitude of the acceleration of the vehicle, of whichever type it may be, is subjected to in the collision or similar. Once the magnitude of the acceleration has been determined, a control unit sets the energy absorber in such a way as to provide a suitable level of damping. The accelerometer and the control unit can be arranged in or adjacent to the energy absorber 8. This can be implemented by providing piston 12 in energy absorber 8 with at least two disks 13, each provided with at least one hole 14. Adjustable damping is obtained as a function of the mutual angle of the two disks 13. When the holes 14 in disks 13 overlap each other, less damping is obtained and when the holes 14 overlap to a lesser extent, more damping is obtained. FIG. 13 shows an example containing two disks 13. One way to arrange the setting of the disks 13 is to have at least one of the disks 13 fixed to the shaft 15 of the energy absorber 8 and

at least one disk **13** fixed at some angle to sleeve **16** of energy absorber **8**, which means that rotation of sleeve **16** by means of motor **17** provides adjustment of the damping. The damping is primarily intended to be only set once and then to be essentially constant during the rest of the damping sequence. Setting takes place before or during the start of the rearward movement.

[0075] FIG. 14 shows another way to implement damping. It is based on designing the energy absorber to give increased damping as the damping movement progresses. The goal is to give the person in seat **1** more gentle braking. The gentler braking is mainly achieved by arranging the volume **18** in which the damping piston **12** moves to have a narrowing cross section **19** in the direction of movement of piston **12**. This narrowing cross section **19** means that damping increases progressively.

[0076] The change in position of seat **1** or parts thereof essentially takes place at the same time as the change in velocity caused by a collision etc.

[0077] One problem associated with whiplash injuries is multiple-car crashes, where the passenger's head is first thrown back, and then when the car collides with the car in front, the head is thrown forwards. In such an event, the currently proposed invention functions excellently and the seat moves back and forwards in a controlled manner to reduce the deceleration during impact with the car in front.

[0078] It should be mentioned that the location of the triggering device, sensors and energy absorber can be arranged in a number of different configurations within the framework of the patent claims, and that their location in the figures are to be regarded as being examples. In addition, the invention should be arranged so that the function of the seat belt and the normal adjustment of the seat are not affected, and they should function normally. Since the seat belt is mounted on the seat and not on the floor, the seat belt will function during the entire crash sequence.

I claim:

1. A device for preventing the occurrence of whiplash injuries to an occupant sitting in a seat, which could occur during a rapid change in motion, such as in a collision essentially from the rear, comprising:

guide means, that during the change in motion provide a change in position in the form of a translation and rotation movement of the seat in direction against the direction of travel,

said guide means are formed by control means provided at the seat and the vehicle, which means are designed to control the backward movement of the seat relative the vehicle, under controlled conditions, of the seat so that its rotation is dependent of the position of the translation along the entire motion path, by means of front and rear track elements provided relative the seat,

said track elements having different angles to the horizontal so that the inclination of the backrest is increasing with increased backward movement along the guide means from a normal sitting position to an increasing backward-inclining position.

2. The device according to claim 1, wherein:

the support means consist of at least one guide means, which is designed to give the front-end of the seat an

upward movement and/or the back-end of the seat a downward movement relative the front end, essentially at the same time as the rearward movement and in dependency of the position along the guide means,

and that the seat is arranged so that it will remain in its rearward position after the change in velocity.

3. The device according to claim 2, wherein:

the guide means are tracks provided with front and rear sections, and that at least two moving devices are mounted at the front and back ends under the seat, provided to cooperate with said tracks, one of the moving device is positioned in the front track section and one moving device positioned in the rear track section,

and wherein in response to a collision of the vehicle from the rear, the seat moves towards the back end of the track and in an inclined motion in accordance with the movement of the moving devices in the front and rear track sections, thereby resulting in the rearward inclination of the seat.

4. The device according to claim 3, wherein the front section of the seat moves upward simultaneously as the seat moves backward in a horizontal direction, thereby resulting in the rearward inclination of the seat.

5. The device according to claim 3, wherein the rear section of the seat moves downward simultaneously as the seat moves backward in a horizontal direction, thereby resulting in the rearward inclination of the seat.

6. The device according to claim 3, wherein both the front section and the rear section of the seat move downward, but the rear section moves downward a greater distance than the front section simultaneously as the seat moves backward in a horizontal direction, thereby resulting in the rearward inclination of the seat.

7. The device according to claim 3, wherein both the front section and the rear section of the seat move upward, but the front section moves up more than the rear section, simultaneously as the seat moves backward in the horizontal direction, thereby resulting in the rearward inclination of the seat.

8. The device according to claim 3, wherein the front section of the seat moves upward simultaneously as the rear section of the seat moves downward, both the front section and rear section movement occurring as the seat moves backward in the horizontal direction, thereby resulting in the rearward inclination of the seat.

9. The device according to claim 3, wherein the front track section comprises an arcuate section of constant or varying radius.

10. The device according to claim 3, wherein the rear track section comprises an arcuate section of constant or varying radius.

11. The device of claim 3, wherein the track sections are shaped to initially give the seat a linear motion against a direction of travel, followed by a swinging, rearward-inclining movement.

12. The device according to claim 2, wherein:

the support means provided for changing positions when the seat moves rearward includes at least one triggering mechanism, arranged to sense the forces or accelerations acting upon the vehicle during the collision,

and wherein if a set force or acceleration is exceeded, the triggering mechanism permits the linear and/or curved movement of the seat.

**13.** The device according to claim 12, wherein the triggering mechanism alters the damping of the linear and/or curved movement in response to the measured force or acceleration.

**14.** The device according to claim 12, comprising at least one energy absorber to damp the linear and/or arcuate movement of the seat in at least one direction.

**15.** The device according to claim 12, when utilized in an application which might allow an individual to be present

behind the seat during normal operation, further comprising a sensor arranged to detect the position of that individual, wherein the sensor limits or checks the linear and/or arcuate movement of the seat.

**16.** The device of claim 12, including means to damp a change in position of the seat after the collision.

**17.** The device of claim 12, including a sensor to detect a person located behind the seat and further including means that in response to such detection limit or prevent a change of position of the seat.

\* \* \* \* \*