



(86) Date de dépôt PCT/PCT Filing Date: 2015/07/10
 (87) Date publication PCT/PCT Publication Date: 2016/01/14
 (85) Entrée phase nationale/National Entry: 2017/01/09
 (86) N° demande PCT/PCT Application No.: EP 2015/065820
 (87) N° publication PCT/PCT Publication No.: 2016/005556
 (30) Priorité/Priority: 2014/07/11 (EP14382273.2)

(51) Cl.Int./Int.Cl. *A61L 2/10* (2006.01),
A23L 3/005 (2006.01), *A61L 2/04* (2006.01),
C02F 1/02 (2006.01), *C02F 1/32* (2006.01)

(71) Demandeurs/Applicants:
 GUAMIS ALEGRE, ALEXANDRE, ES;
 SALAS VICENTE, FIDEL, ES;

(72) Inventeurs/Inventors:
 GUAMIS ALEGRE, ALEXANDRE, ES;
 SALAS VICENTE, FIDEL, ES;
 SALAS VICENTE, JOSE, ES;
 GUAMIS ALEGRE, DAVID, ES;
 MORETA BUFILL, LEO, ES

(74) Agent: GOWLING WLG (CANADA) LLP

(54) Titre : SYSTEME ET PROCEDE DE STERILISATION DE FLUIDE
 (54) Title: SYSTEM AND METHOD FOR STERILIZING A FLUID

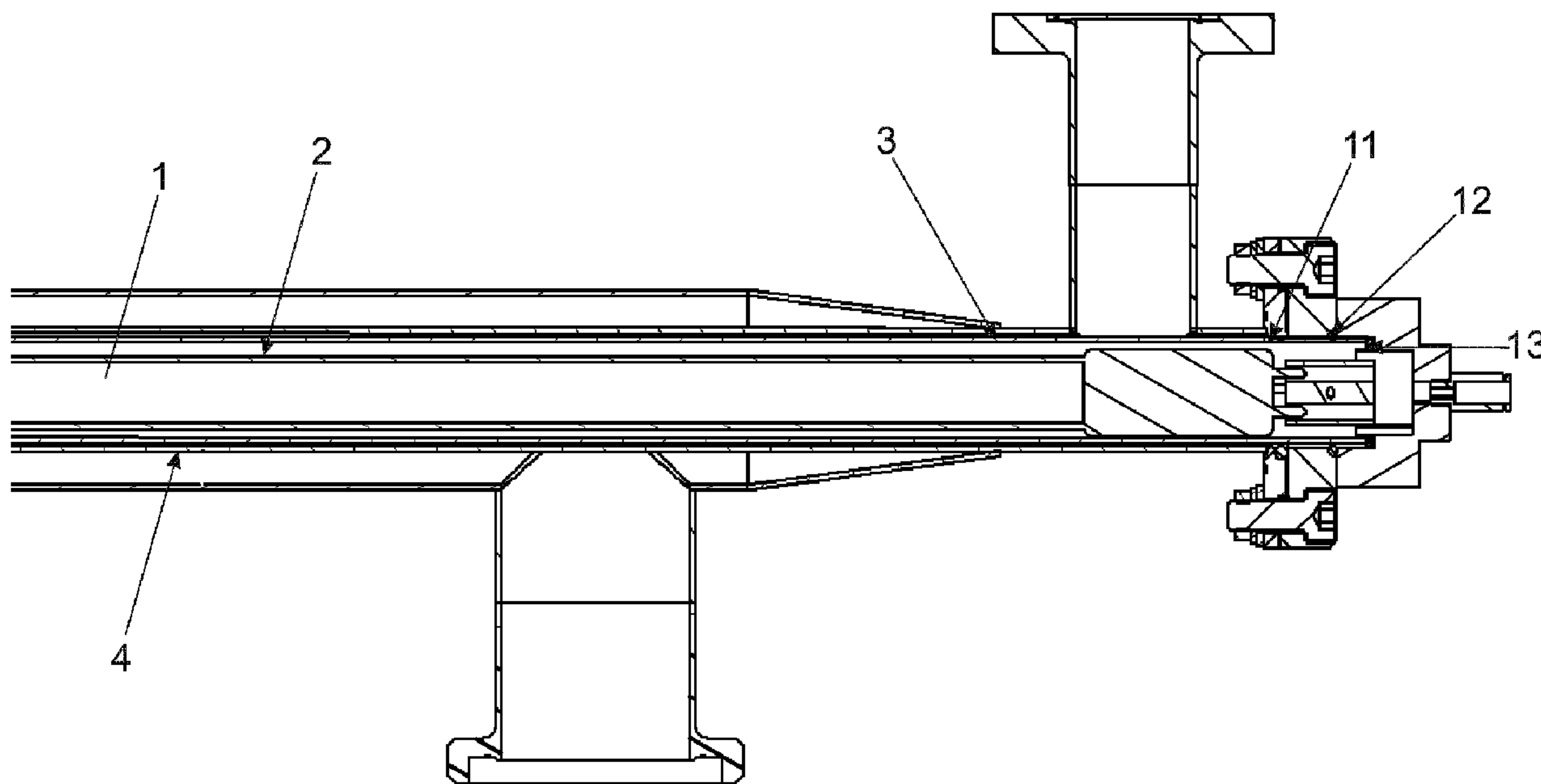

Fig. 3

(57) Abrégé/Abstract:

System and method for sterilizing a fluid. The system comprises a UV emitter (1) surrounded by an elongated element (2) arranged concentrically with respect to the UV emitter through which a coolant fluid cooling the UV emitter circulates, the elongated element

(71) **Demandeurs(suite)/Applicants(continued):** SALAS VICENTE, JOSE, ES; GUAMIS ALEGRE, DAVID, ES;
MORETA BUFILL, LEO, ES

(57) **Abrégé(suite)/Abstract(continued):**

(2) being surrounded by an elongated element (3) arranged concentrically with respect to the UV emitter through which the fluid to be sterilized circulates, the elongated element being (3) surrounded by an elongated element (4) arranged concentrically with respect to the UV emitter through which a coolant or heating fluid cooling or heating the fluid to be sterilized circulates. In the method for sterilizing a fluid, the fluid to be sterilized is subjected to UV radiation at a temperature ranging between -20 ° C and 160 ° C.

(12) INTERNATIONAL APPLICATION PUBLISHED UNDER THE PATENT COOPERATION TREATY (PCT)

(19) World Intellectual Property
Organization
International Bureau(10) International Publication Number
WO 2016/005556 A1(43) International Publication Date
14 January 2016 (14.01.2016)

(51) International Patent Classification:

A61L 2/00 (2006.01) C02F 1/02 (2006.01)
A61L 2/04 (2006.01) C02F 1/32 (2006.01)
A61L 2/10 (2006.01)

(21) International Application Number:

PCT/EP2015/065820

(22) International Filing Date:

10 July 2015 (10.07.2015)

(25) Filing Language:

English

(26) Publication Language:

English

(30) Priority Data:

14382273.2 11 July 2014 (11.07.2014) EP

(72) Inventors; and

(71) Applicants : GUAMIS ALEGRE, Alexandre [ES/ES];
C/ Martinez de la Rosa, 8, 4° 1°, E-08012 Barcelona (ES).
SALAS VICENTE, Fidel [ES/ES]; Avda. Castellón, 5, E-
12412 Geldo (ES). SALAS VICENTE, José [ES/ES];
Avda. Castellón, 5, E-12412 Geldo (ES). GUAMIS
ALEGRE, David [ES/ES]; c/ Martinez de la Rosa, 8,
4°,1°, E-08012 Barcelona (ES). MORETA BUFILL, Leo
[ES/ES]; C/Rambla Catalunya, 102, 2° 1ª, E-08008 Bar-
celona (ES). GERVILLA FERNANDEZ, Ramón
[ES/ES]; C/ Pablo Picasso, Nº 19, E-08100 Mollet del
Vallés (ES).

(74) Agents: CARVAJAL Y URQUIJO, Isabel et al.; c/Suero
de Quiñones, 34-36, E-28002 Madrid (ES).

(81) Designated States (unless otherwise indicated, for every
kind of national protection available): AE, AG, AL, AM,
AO, AT, AU, AZ, BA, BB, BG, BH, BN, BR, BW, BY,
BZ, CA, CH, CL, CN, CO, CR, CU, CZ, DE, DK, DM,
DO, DZ, EC, EE, EG, ES, FI, GB, GD, GE, GH, GM, GT,
HN, HR, HU, ID, IL, IN, IR, IS, JP, KE, KG, KN, KP, KR,
KZ, LA, LC, LK, LR, LS, LU, LY, MA, MD, ME, MG,
MK, MN, MW, MX, MY, MZ, NA, NG, NI, NO, NZ, OM,
PA, PE, PG, PH, PL, PT, QA, RO, RS, RU, RW, SA, SC,
SD, SE, SG, SK, SL, SM, ST, SV, SY, TH, TJ, TM, TN,
TR, TT, TZ, UA, UG, US, UZ, VC, VN, ZA, ZM, ZW.

(84) Designated States (unless otherwise indicated, for every
kind of regional protection available): ARIPO (BW, GH,
GM, KE, LR, LS, MW, MZ, NA, RW, SD, SL, ST, SZ,
TZ, UG, ZM, ZW), Eurasian (AM, AZ, BY, KG, KZ, RU,
TJ, TM), European (AL, AT, BE, BG, CH, CY, CZ, DE,
DK, EE, ES, FI, FR, GB, GR, HR, HU, IE, IS, IT, LT, LU,
LV, MC, MK, MT, NL, NO, PL, PT, RO, RS, SE, SI, SK,
SM, TR), OAPI (BF, BJ, CF, CG, CI, CM, GA, GN, GQ,
GW, KM, ML, MR, NE, SN, TD, TG).

Declarations under Rule 4.17:

— of inventorship (Rule 4.17(iv))

Published:

— with international search report (Art. 21(3))

(54) Title: SYSTEM AND METHOD FOR STERILIZING A FLUID

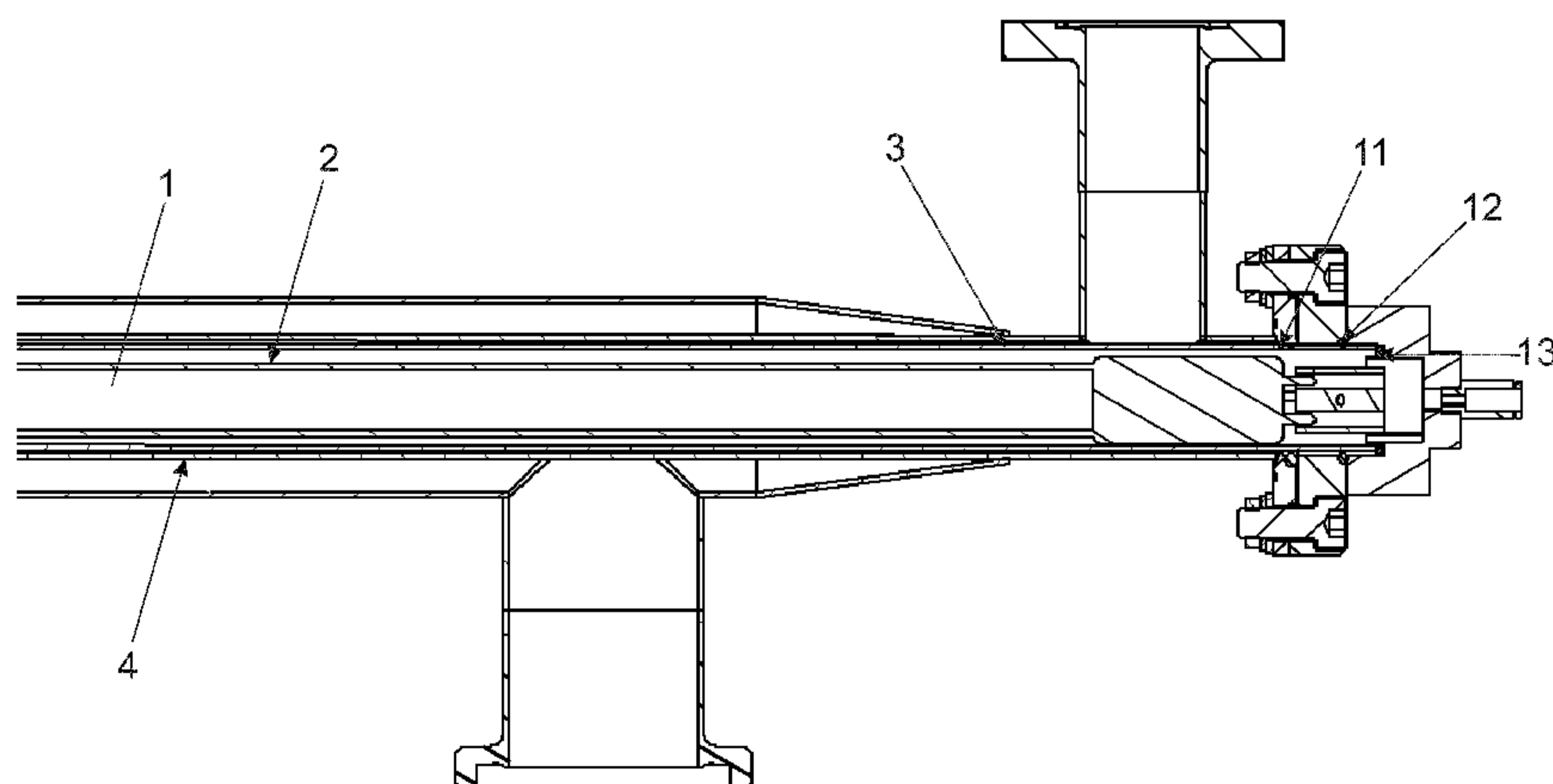

Fig. 3

(57) Abstract: System and method for sterilizing a fluid. The system comprises a UV emitter (1) surrounded by an elongated element (2) arranged concentrically with respect to the UV emitter through which a coolant fluid cooling the UV emitter circulates, the elongated element (2) being surrounded by an elongated element (3) arranged concentrically with respect to the UV emitter through which the fluid to be sterilized circulates, the elongated element being (3) surrounded by an elongated element (4) arranged concentrically with respect to the UV emitter through which a coolant or heating fluid cooling or heating the fluid to be sterilized circulates. In the method for sterilizing a fluid, the fluid to be sterilized is subjected to UV radiation at a temperature ranging between -20 ° C and 160 ° C.

WO 2016/005556 A1

SYSTEM AND METHOD FOR STERILIZING A FLUID

Field of the invention

The present invention relates to a system for processing fluids for sanitization and/or sterilization thereof by means of the controlled sequential and/or simultaneous application of germicidal ultraviolet radiation (preferably type C) and temperature, which may range from cooling to moderate (preferably) and high temperatures of products such as foods, ingredients, perfumes, scents, cosmetics, pharmaceutical products (medicines), hospital products (sera, haematological fluids, etc.), chemicals, products containing alcohol, petroleum derivatives, etc., and the like.

Background of the invention

A problem to be solved in the industry consists of sanitizing or sterilizing fluids (foods, ingredients, perfumes, scents, cosmetics, pharmaceutical products (medicines), hospital fluids (sera, haematological fluids, etc.), chemicals, products containing alcohol, petroleum derivatives etc., and the like), which due to their specific characteristics, are sensitive to specific thermal treatments, thereby suffering a loss of quality, at the functional or technological level (foaming, emulsifying, colouring, thickening, texturizing capacities, etc.), at the nutritional level (loss of vitamins, aminoacids and essential fatty acids, polyphenols, antioxidants, etc.) or at the organoleptic level (loss of scents, flavours, colours, textures, etc.).

UVC light has been applied in the purification and treatment of water as a low-cost, safe alternative for improving taste and odour. UVC light has a bactericidal effect on microorganisms. Although it is considered a bactericide, it affects all the types of microscopic organisms (viruses, bacteria, algae, fungi, yeasts and protozoa). The disinfecting power of UVC light is the result of its action on cellular DNA, causing a decrease in their respiratory activity, blocking the processes of synthesis and inhibiting or retarding mitosis. On the other hand, the effect of UVC light on two contiguous thymine or cytosine bases (pyrimidines) in the same strand of DNA or RNA generates the respective dimers, preventing DNA or RNA replication in the microorganisms, and thus their reproduction.

The bactericidal action of UVC light depends primarily on the dose applied to the microorganism, and the same is dependent on the irradiance and application time. Irradiance is the potency of UV light per unit area measured in microwatts per square centimetre. The corresponding dose is the product of the irradiance per application time and it is expressed in millijoules per square centimetre or the equivalent in microwatts

per second per square centimetre.

Another feature of UVC light is that its bactericidal effect is cumulative over time (dose).

UV radiation minimizes the formation of chemicals and/or by-products. This process is also dry, cold, and requires little maintenance and has lower running costs compared with conventional thermal processes, wherein energy consumption is very high. On the other hand, because these are cold or moderate temperature processes, the unwanted effects of conventional thermal treatments are prevented. For these reasons, there is a growing interest in using UVC light for disinfecting foods. However, every food, cosmetic, pharmaceutical product, etc., has its own composition and this may determine that required UVC doses are different between them. A disadvantage of using UVC light for sanitizing is the low transmittance of the majority of fluids, which entails that only thin layers near the emitter may be treated efficiently.

The low transmittance of UVC light in most liquids other than water is well known. The effect of UVC light penetration depends on the type of liquid, the absorbance at the specified wave length, solutes present in the liquid and suspended material. Increasing the amount of solids will reduce the penetration intensity of UVC radiation, just as, large suspended particles may also block the incidence of light on the microbial load. For example, UV light penetration in juices ranges between several hundreds of microns and a few millimetres, due to a 90 % absorption of light caused by their compounds or suspended particles.

In certain foods or technological processes it might be necessary to reduce or inactivate certain enzymes, as for example, in vegetable or fruit juices, the inactivation of Pectin-Methyl-Esterase (PME), which causes loss of texture, Peroxidase (PO), catalysing oxidation processes, or Poly-Phenol-Oxidase (PFO) which has a role in darkening or browning reactions, oxidizing phenolic compounds to quinones. With respect to the effect of UVC on the enzymes, in general they cause some degree of inactivation, in accordance with the dose and matrix in which they are found.

At present there are different basic types of UV emitters available, of which the emitters based on mercury vapour may be highlighted.

In terms of killing germs, low pressure emitters are often the most widely used in the industry, since they offer an almost monochromatic emission that is condensed in 254 nm, very close to the absorption maximum of the DNA molecule at 260 nm and with easy handling and manipulation. Compared to medium pressure and high pressure emitters, low pressure emitters have better performance (30 - 40 % versus the 10 - 15 %

of medium pressure) and work at more moderate temperatures (40 °C - 110 °C versus 600 °C - 900 °C), although the UV potency emitted per wave length unit is much lower.

Description of the invention

The present invention provides a system for sterilizing a fluid, comprising a UV
5 emitter (1) surrounded by an elongated element (2) arranged concentrically with respect
to the UV emitter, through which a coolant fluid cooling the UV emitter circulates, the
elongated element (2) being surrounded by an elongated element (3) arranged
concentrically with respect to the UV emitter, through which the fluid to be sterilized
circulates, the elongated element (3) being surrounded by an elongated element (4),
10 arranged concentrically with respect to the UV emitter, through which a coolant or
heating fluid cooling or heating the fluid to be sterilized circulates, hereinafter system of
the invention.

In the present specification, the term “fluid” is a liquid or gas.

One embodiment is the system of the invention, wherein the elongated element
15 (3) through which the fluid to be sterilized circulates has coarse walls or spiral
pathways.

This makes that the fluid to be sterilized circulate in a turbulent and non-laminar
manner, to ensure that entire fluid volume is subjected to the same treatment or dose of
UVC dose and temperature.

20 In the present invention, the thickness of the layer of fluid to be treated may
even be lower than 1 mm. The back pressure to which the fluid is subjected (by means
of a back pressure valve) together with the turbulence promoters, make the fluid to be
treated circulate in a turbulent flow manner during processing thereof even in such tight
spaces.

25 Different bibliographical sources suggest that it is necessary for all parts of the
fluid to be exposed to at least a dose of 400 J/m² (40 mJ/cm²) of UVC light (254 nm) to
ensure an adequate 5 Log reduction of a target or marker microorganism, to obtain (in
the case of food industry) a microbiologically safe food. Considering that said dose of
UVC should be applied to the entire system to ensure that the liquid fluid is treated
30 equally.

In the present invention, said dose or higher doses may be reached at the end of
the treatment, since the system is designed so that an indefinite number of systems may
be coupled together in a series. Also, the intensity of cutting-edge lamps (both excimer
and mercury arc emitters), which are capable of giving said dose in just a few seconds
35 of treatment, makes it so that said dose may be easily reached. Moreover, with

regulation of the flow rate (the speed at which the fluid will circulate through the system) by means of the impeller pump, it is possible to increase the treatment time and therefore the dose. The present invention factors in the possibility that, should it be necessary to reduce the flow rates through the systems, groups of systems may be coupled together in parallel, in order to prevent the reduction of the total production flow rate (L/hour) of the equipment.

Another embodiment is the system of the invention, wherein the fluid to be sterilized is selected from the group consisting of a food, a cosmetic, a drug, a pharmaceutical composition, hospital fluid, a scent, a perfume and a chemical compound.

Another embodiment is the system of the invention, wherein the UV emitter emits a wave length of between 200 and 312 nm.

Another embodiment is the system of the invention, wherein the distance between the external wall of the elongated element (2) and the internal wall of the elongated element (3) is between 0.5 and 5 mm.

Another embodiment is the system of the invention, wherein one or more systems may be coupled together in series or in parallel. In particular, one of the systems has a UV emitter that emits at a wave length of between 290 and 320 nm.

The present invention also optionally factors in the possibility of using one or several (an assembly) UVB systems, with the same design as the UVC systems, and which therefore may be coupled together in series or in parallel, and placed after the UVC systems. The main purpose of the UVC systems would be to apply longer wave length treatments to repair or rebuild certain compounds, which depending on the composition of the fluid to be treated, might be degraded or react (primarily by oxidation) with other compounds of the fluid itself, slightly (but perhaps noticeably) changing the biochemical, organoleptic and/or nutritional characteristics of the treated fluid, and in the case of foods, for example, bringing about a loss of quality in said food. The use of said step is to be optional, because utilization thereof will be highly influenced by the desired expectations of the final product, as well as of the final composition of the product (fats, proteins, sugars, etc.).

Another embodiment is the system of the invention, comprising devices for measuring and controlling the emission irradiance of the UV emitter.

Another embodiment is the system of the invention, comprising devices for measuring and controlling the temperatures.

Since the UVC lamp that is found at the centre of the system and is hermetically

insulated from the rest of the concentric tubes through which the fluid to be sterilized and the coolant and heating fluids circulate, the coatings forming the spaces wherein these fluids circulate require connector tubes (independent between both fluids) at the system outlets connecting to the inlets of the next system, to be used as a circulation system. The coolant or heating fluid passing through the system is re-circulated, whereas the fluid to be sterilized (e.g. food), even though it could also be re-circulated through the system, is preferably treated continuously by means of the groups of systems in series or in parallel, without being recirculated, unless a drop in any of the variables makes it so that the required dose is not reached, thus diverting the product (by means of a diverter valve) to the initial tank or receptacle for subsequent recirculation. A conditioning system for cooling/heating may be added at the inlet or outlet of the system to cool/heat the fluid to be treated before and after the UV light treatment.

The dose should be administered equally to the entire product volume, and as has been described, in the present invention this is achieved in the system of the invention. Different factors may help to achieve an equal dose in the entire product volume, for example: that the product has to be circulated through several (2 or more) systems in series or in parallel; that between these systems, the pipes (connecting the outlets to the inlets of the next one) have different section volumes than the section volumes in the segment of the system; that the geometrical and spatial arrangement of the systems forces the fluid or product to change its direction in the space (not the direction within the section through which the fluid circulates), either by placing horizontally or vertically (or alternating), direction changes from right to left or vice versa between systems (always taking into account that the outlet of one goes to the inlet of the other); that the circuit of fluid to be treated (product) may be counter-pressured by means of the back pressure valve (at the end of the circuit); that the presence of homogenizers at the outlet of a system forces the fluid to mix before the inlet of the next one; that the presence of turbulence promoters, in the chamber through which the fluid to be treated passes, increases turbulence and homogenization of the latter.

The possibility of applying different controlled temperatures at the same time as the UV are applied to the fluid to be treated and in such an efficient and homogeneous manner, may be useful for different applications such, for example:

- Obtaining synergistic microbial inactivation results, i.e. which exceed those that would be obtained if added together, applying the UVC and temperature

separately.

- Obtaining total microbial inactivation for various kinds of microorganisms with varying degrees of sensitivity to ultraviolet light and the thermal process, thus enabling the use more moderate temperatures.
- 5 - Obtaining enzymatic inactivation, by means of applying moderate temperatures, for example of between 60-80 °C.
- Obtaining synergistic enzymatic inactivation results, which exceed the total of separate UVC and temperature treatments.
- Causing certain components (for example proteins) to stabilize in certain fluids
10 at moderate temperatures.
- Facilitating the homogenization, dissolution and dispersion of various compounds in the fluids to be treated, as a result of the low or moderate temperatures.
- Encouraging the kinetics of certain chemical or enzymatic reactions using low
15 or moderate temperatures, which benefit the final objectives of the fluid to be treated.
- The temperature and the control thereof may encourage the fluidity of the products or fluids having a certain level of viscosity, thereby facilitating the circulation thereof through the entire circuit.
- 20 - The temperature and the control thereof may facilitate cleaning processes in the circuit, once production has come to an end, since it helps to dissolve and drag residues of the treated fluids, and furthermore increases the effectiveness of cleaning products such as, for example, alkalis (NaOH at 3 % and 80 °C), acids (HNO₃ “nitric acid” at 2 % and 45-50 °C), commercial detergents, enzyme
25 products, peracetic acid (C₂H₄O₃), hydrogen peroxide (H₂O₂), etc.
- The temperature and the control thereof may facilitate the disinfection and sterilization of the areas in the system when high temperatures are employed.

The present invention factors in various safety systems to prevent and detect
problems of leaks and breakages between concentric tubes, and more specifically in
30 those related to the UV emitters and the material surrounding this emitter, which is preferably quartz. Said safety systems provide higher safety regarding possible deviations of materials (quartz) to the fluids to be treated, damage to facilities by electrical shorts, safety for operators and, above all, provide a safety system of the pre-set conditions, both of UV dosage (intensity and time), temperature, and back pressure
35 of the treatment, preventing the “poorly” treated fluid from getting packaged as correct.

Such security measures may be listed in summary form as:

- Having temperature sensors along the circuit, and primarily (but not exclusively) at the outlet of the systems, which constantly send information about the temperature of the fluid to be treated to the control panel.
- 5 - Having sensors measuring the irradiance of non-ionizing radiation (UVC and/or UVB) inside each system and which constantly send information about the irradiance emitted by the emitter to the control panel.
- Having a thin electric track in the quartz of the emitter and/or protective quartz cover. Any breakage of the quartz would cause a breakage of the conductive track and therefore would cut the electrical current flow, signalling to the control panel, and the latter taking the actions programmed. Said conducting wire, preferably, but not exclusively, may be made of gold.
- 10 - Having a UV-transparent polymeric cover over the quartz which, should breakage occur, contains the splinters and prevents them from joining the fluid to be treated.
- 15 - Having gaskets providing air-tightness and sealing the junctions between the UV emitter and the quartz cover. Said gaskets are made with a design and materials (for example, but not limited to, fluorinated polymer) that tolerate the most extreme conditions of CIP-type (Clean in Place) cleaning and disinfecting and SIP (Steam in Place) sterilization, commonly used in food industries .
- 20 - Having a back pressure system (preferably a back pressure valve, although not exclusively) and exerting a constant pressure on the forward movement of the fluid to be treated, and thus helping to generate turbulent flow profiles.
- Having a "Control Panel" that actuates a diverter valve that diverts the fluid to be treated placed before the hygienic or aseptic packaging system (tank and packer), said conditioning of the diverter valve may be due to failure of any of the initially pre-set conditions, such as (preferably, but not limited to) the temperature, the UVC or UVB light intensity, treatment time (settings of the flow rate through the pumps impelling the product), breakage of the lamp or quartz cover, loss of product pressure, etc., which would keep product which has not been properly treated from being packaged (preferably, but not exclusively, that does not reach the reservoir or aseptic tank for further hygienic or aseptic packaging), such that the product could be diverted by means of the diverter valve to the initial tank for recirculation, or to any other tank in order to discard the product or otherwise.
- 25
- 30
- 35

The invention also provides a method for the sterilization of a fluid, which is carried out in a system comprising a UV emitter (1) surrounded by an elongated element (2) arranged concentrically with respect to the UV emitter through which a coolant fluid cooling the UV emitter circulates, the elongated element (2) being surrounded by an elongated element (3) arranged concentrically with respect to the UV emitter through which the fluid to be sterilized circulates, the elongated element (3) being surrounded by an elongated element (4) arranged concentrically with respect to the UV emitter through which a coolant or heating fluid cooling or heating the fluid to be sterilized circulates, which comprises subjecting the fluid to be sterilized to UV radiation at a temperature ranging between -20 °C y 160 °C.

Another embodiment is the method of the invention, wherein the temperature ranges between 2 and 80 °C.

Brief description of the drawings

Figure 1. Shows an external side view of the system of the invention, wherein it is possible to observe the arrangement of the inlet and outlet points of the various fluid circuits: inlet (5) and outlet (6) of the fluid to be sterilized, inlet (7) and outlet (8) of the coolant or heating fluid, air inlet (9) and outlet (10).

Figure 2. Shows a longitudinal section of the system of the invention, wherein it is possible to observe the arrangement of the various chambers through which the various fluids circulate, as well as the arrangement of the UV emitter.

Figure 3. Shows an enlarged view of the longitudinal section, wherein it is possible to observe in greater detail the arrangement of the chambers through which the various fluids circulate: air (2), fluid to be sterilized (3), coolant or heating liquid (4), UV emitter (1). It is also possible to observe the arrangement of the gaskets or seals (11, 12, 13) that provide air-tightness between the emitter, the quartz cover and the chamber through which the product circulates.

Preferred embodiments

Example 1. Effect of UVC light treatment on lethality in different microorganisms.

By way of example to demonstrate the effectiveness of the present invention, various microorganisms having different levels of sensitivity to UVC treatment were studied in an aqueous solution having a low absorbance coefficient (0.43 cm^{-1}) and in liquid egg white having a high absorbance coefficient (107 cm^{-1}), at different temperatures, 20 and 50 °C in the treatment with inoculated aqueous solutions and at 20 and 55 °C in the treatments with inoculated liquid egg whites. The concentration of microorganisms in the control samples amounted to approximately 10^6 - 10^7 cfu/ml. To

calculate the dose received (Equation 1), it was necessary to calculate the transmitted Irradiance (I) by means of the Beer-Lambert Law (Equation 2) taking into account the thickness of the fluid, path length (for the aqueous solution and liquid egg white), which was 1 mm ($d = 0.1$ cm), the absorbance coefficients for $\lambda = 254$ nm (described above) and incident Irradiance ($I_0 = 31$ mW/cm²). The microbiological results in Tables 1-3 are expressed as lethality (Equation 3).

$Dose = Irradiance \cdot Time$ (Equation 1)

In Equation 1, $Dose$ is expressed in mW·S/cm², $Irradiance$ is expressed in mW/cm² and $Time$ is expressed in seconds.

$I = I_0 \cdot 10^{-\epsilon d}$ (Equation 2)

In Equation 2, I is transmitted Irradiance, I_0 is incident Irradiance, ϵ is Absorbance coefficient and d is path length.

$Lethality = Log_{10}(N_0/N)$ (Equation 3)

In Equation 3, N_0 is the initial cfu/cm² number before the treatment and N is the cfu/cm² number after the treatment.

Table 1. Effect of UVC light treatment with an irradiance of 31 mW/cm² at 20 °C for different exposure times on the lethality of different microorganisms in an aqueous solution (Absorbance coefficient: 0.43 cm⁻¹). Data from three independent experiments with duplicated quantification of the results of every experiment (n=6). The average \pm standard deviation is shown. Lethality is expressed in cfu/cm².

	Exposure time (seconds)					
	3 s	6 s	12 s	18 s	24 s	30 s
<i>A. niger</i> (spores)	0.47 \pm 0.27	1.12 \pm 0.15	2.04 \pm 0.05	3.58 \pm 0.04	4.15 \pm 0.17	\geq 5.1
<i>B. subtilis</i> (spores)	1.53 \pm 0.55	2.9 \pm 0.31	4.88 \pm 0.31	5.91 \pm 0.23	\geq 6.5	---
<i>S. aureus</i>	3.43 \pm 0.13	5.43 \pm 0.64	\geq 6.7	---	---	---
<i>E. coli</i>	4.83 \pm 0.24	5.79 \pm 0.96	\geq 6.9	---	---	---
<i>L. innocua</i>	3.28 \pm 0.28	4.93 \pm 0.65	\geq 6.8	---	---	---
<i>M. luteus</i>	2.53 \pm 0.21	5.32 \pm 0.71	\geq 6.5	---	---	---
<i>P. fluorescens</i>	2.71 \pm 0.25	4.75 \pm 0.53	\geq 7.1	---	---	---

Table 2. Effect of UVC light treatment with an irradiance of 31 mW/cm² at 50 °C for different exposure times on the lethality of different microorganisms in an aqueous solution (Absorbance coefficient: 0.43 cm⁻¹). Data from three independent experiments with duplicated quantification of the results of every experiment (n=6). The average ± standard deviation is shown. Lethality is expressed in cfu/cm².

	Exposure time (seconds)					
	3 s	6 s	12 s	18 s	24 s	30 s
<i>A. niger</i> (spores)	0.43 ± 0.31	1.25 ± 0.13	2.28 ± 0.08	3.82 ± 0.21	4.86 ± 0.08	≥ 5.1
<i>B. subtilis</i> (spores)	1.31 ± 0.44	2.94 ± 0.38	4.82 ± 0.44	6.01 ± 0.33	≥ 6.5	---
<i>S. aureus</i>	3.17 ± 0.15	6.33 ± 0.45	≥ 6.7	---	---	---
<i>E. coli</i>	4.16 ± 0.22	6.9	---	---	---	---
<i>L. innocua</i>	3.07 ± 0.21	5.94 ± 0.75	≥ 6.8	---	---	---
<i>M. luteus</i>	2.88 ± 0.36	5.14 ± 0.89	≥ 6.5	---	---	---
<i>P. fluorescens</i>	3.58 ± 0.34	6.34 ± 0.44	≥ 7.1	---	---	---

Table 3. Effect of UVC light treatment with an irradiance of 31 mW/cm² for different exposure times on the lethality of different microorganisms in liquid egg white (Absorbance coefficient: 107 cm⁻¹). Data from three independent experiments with duplicated quantification of the results of every experiment (n=6). The average ± standard deviation is shown. Lethality is expressed in cfu/cm².

	Exposure time (seconds)					
	3 s	6 s	12 s	18 s	24 s	30 s
20°C						
<i>B. subtilis</i> (spores)	0.21 ± 0.18	0.51 ± 0.21	1.12 ± 0.28	1.74 ± 0.12	2.4 ± 0.42	3.1 ± 0.54
<i>M. luteus</i>	0.5 ± 0.21	1.04 ± 0.33	1.96 ± 0.24	3.15 ± 0.23	4.01 ± 0.33	5.3 ± 0.64
<i>E. coli</i>	1.01 ± 0.61	1.62 ± 0.15	3.21 ± 0.33	5.02 ± 0.31	6.3 ± 0.25	≥ 6.4
55°C						
<i>B. subtilis</i> (spores)	0.19 ± 0.26	0.6 ± 0.63	0.98 ± 0.15	1.8 ± 0.41	2.51 ± 0.5	2.95 ± 0.58
<i>M. luteus</i>	0.66 ± 0.07	1.14 ± 0.21	2.14 ± 0.2	3.71 ± 0.05	4.68 ± 0.18	6.1 ± 0.15
<i>E. coli</i>	1.2 ± 0.23	1.88 ± 0.24	3.55 ± 0.54	5.88 ± 0.33	≥ 6.4	---

Starting from the data expressed in the above tables (Table 1-3) it has been observed that lethality increases linearly and proportionally at longer exposure times, at least in the time ranges which have been tested.

5 When an Irradiance of 31 mW/cm^2 was applied, at 20°C in aqueous solutions having a low absorbance coefficient (0.43 cm^{-1}) and times were between 3 and 6 seconds, lethality levels (reductions) of between 2.5-5.8 Logarithmic units (Log) were reached in vegetative bacteria, whereas the more ultraviolet-resistant microorganisms (*B. subtilis* spores and *A. niger* spores) reached reductions of 0.5-3 Log.

10 When an Irradiance of 31 mW/cm^2 was applied, at 20°C in fluids having a high absorbance coefficient (107 cm^{-1}), such as liquid egg white, and times were between 6 and 18 seconds, the reductions were 1.6-5, 1-3 and 0.5-1.7 Log for the vegetative bacteria (*E. coli* and *M. luteus*) and *B. subtilis* spores, respectively.

15 When an irradiance of 31 mW/cm^2 was applied, at 50°C in aqueous solutions having a low absorbance coefficient (0.43 cm^{-1}), and times were between 3 and 6 seconds, lethality levels (reductions) of between 3 and ≥ 6.9 Log were reached in vegetative bacteria, whereas in the sporulated microorganisms (*B. subtilis* spores and *A. niger* spores) reductions of 0.4-3 Log were achieved, nearly the same as when room temperature was applied (20°C).

20 However, when an Irradiance of 31 mW/cm^2 was applied, at 55°C in fluids having a high absorbance coefficient (107 cm^{-1}), such as liquid egg white, and times were between 6 and 18 seconds, the reductions were 2-6, 1-3,7 and 0,6-1,8 Log for the vegetative bacteria (*E. coli* and *M. luteus*) and *B. subtilis* spores, respectively.

25 Furthermore, the liquid egg white (LEW) samples treated with or without UVC and/or temperature, never coagulated and conserved the main functional characteristics (colour, odour, viscosity, foaming capacity, etc.).

CLAIMS

1.- A system for sterilizing a fluid, characterized in that it comprises a UV emitter (1) surrounded by an elongated element (2), arranged concentrically with respect to the UV emitter, through which a coolant fluid cooling the UV emitter circulates, the elongated element (2) being surrounded by an elongated element (3), arranged concentrically with respect to the UV emitter, through which the fluid to be sterilized circulates, the elongated element (3) being surrounded by an elongated element (4), arranged concentrically with respect to the UV emitter, through which a coolant or heating fluid cooling or heating the fluid to be sterilized circulates.

2.- The system according to claim 1, characterized in that the elongated element (3) through which the fluid to be sterilized circulates has coarse walls or spiral pathways.

3.- The system according to one of the claims 1 or 2, characterized in that the fluid to be sterilized is selected from the group consisting of a food, a cosmetic, a drug, a pharmaceutical composition, a hospital fluid, a scent, a perfume and a chemical compound.

4.- The system according to any of the claims 1 to 3, characterized in that the UV emitter emits at a wave length of between 200 and 312 nm.

5.- The system according to the claims 1 to 4, characterized in the distance between the external wall of the elongated element (2) and the internal wall of the elongated element (3) is between 0.5 and 5 mm.

6.- The system according to any of the claims 1 to 5, characterized in that two or more systems may be coupled together in series or in parallel.

7.- The system according to claim 6, characterized in that one of the systems has a UV emitter that emits at a wave length of between 290 and 320 nm.

8.- The system according to any of the claims 1 to 7, characterized in that it comprises devices for measuring and controlling the emission irradiance of the UV

emitter.

9.- The system according to any of the claims 1 to 8, characterized in that it comprises devices for measuring and controlling the temperatures.

5

10.- A method for the sterilization of a fluid, characterized in that it is carried out in a system comprising a UV emitter (1) surrounded by an elongated element (2) arranged concentrically with respect to the UV emitter through which a coolant fluid cooling the UV emitter circulates, the elongated element (2) being surrounded by an elongated element (3) arranged concentrically with respect to the UV emitter through which the fluid to be sterilized circulates, the elongated element (3) being surrounded by an elongated element (4) arranged concentrically with respect to the UV emitter through which a coolant or heating fluid cooling or heating the fluid to be sterilized circulates, and in that it comprises subjecting the fluid to be sterilized to UV radiation at a temperature ranging between -20 °C and 160 °C.

10

15

11.- The method according to claim 10, characterized in that the temperature ranges between 2 and 80 °C.

1 / 3

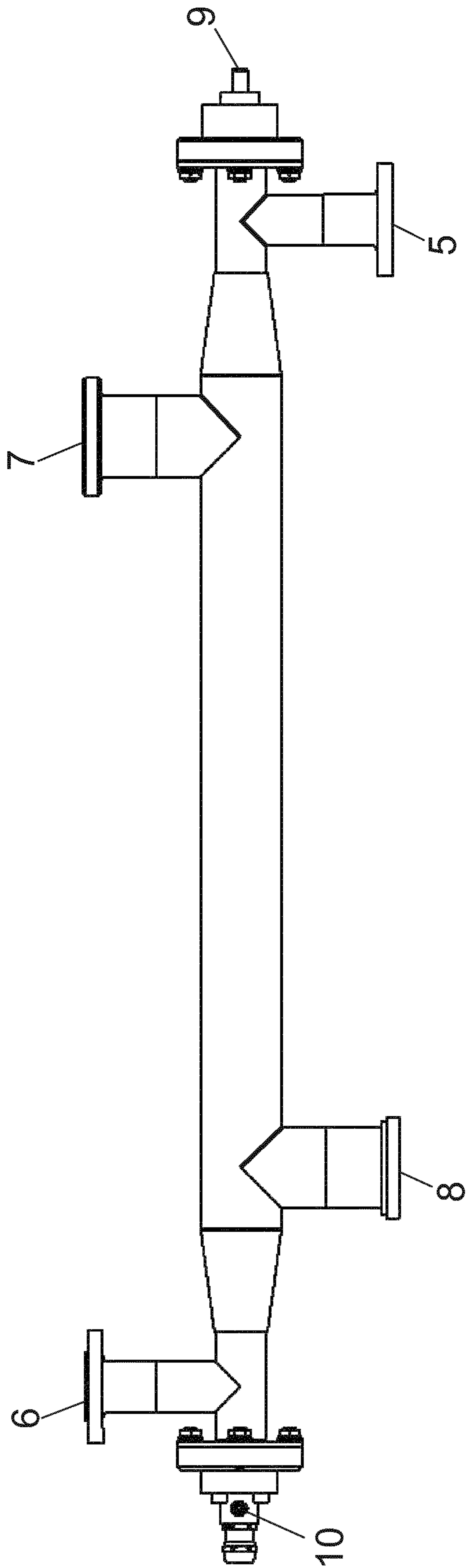

Fig. 1

2 / 3

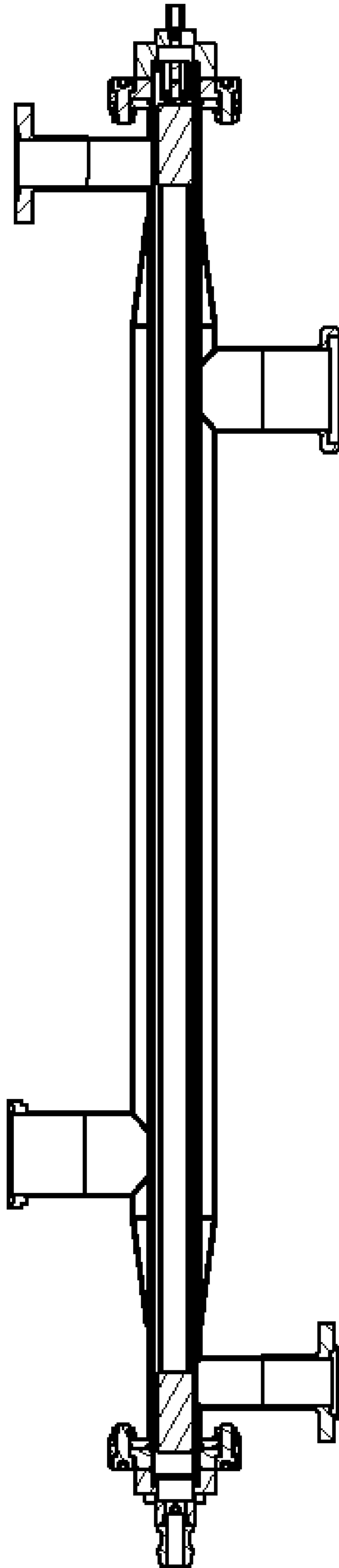

Fig. 2

3 / 3

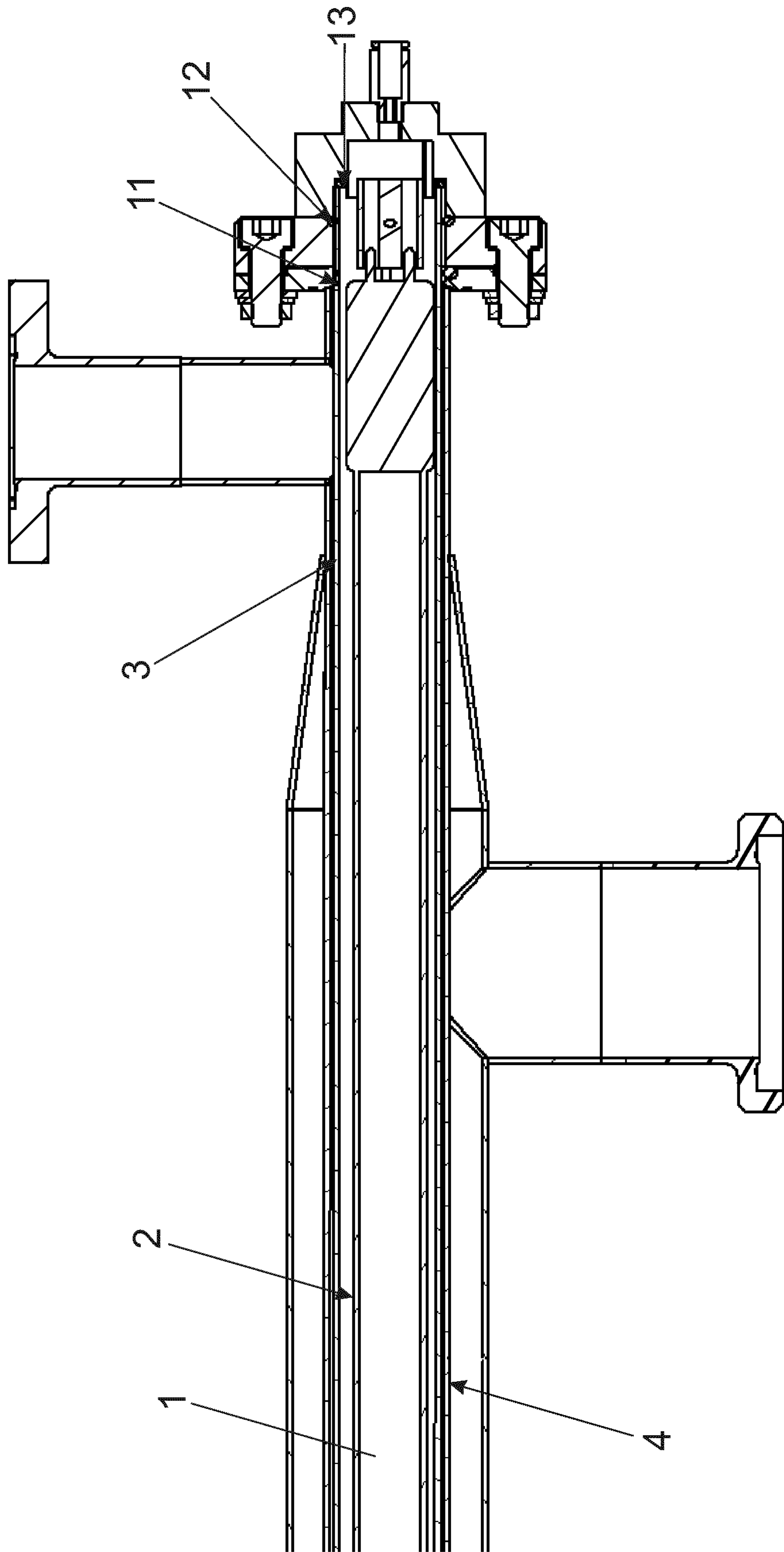

Fig. 3

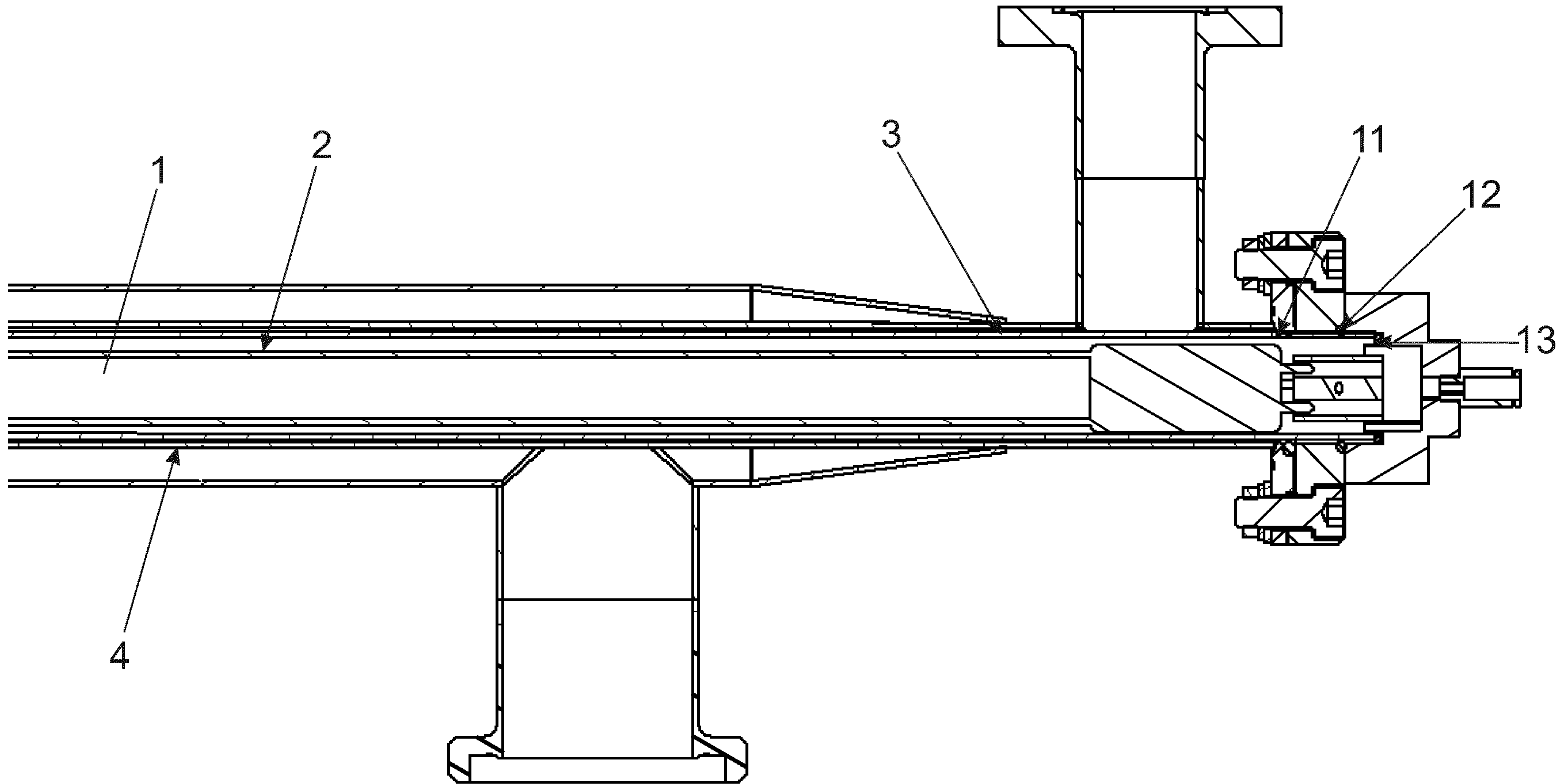

Fig. 3