



## INTERNATIONAL APPLICATION PUBLISHED UNDER THE PATENT COOPERATION TREATY (PCT)

<p>(51) International Patent Classification <sup>6</sup> : <b>A61M 15/00</b></p>	<p><b>A1</b></p>	<p>(11) International Publication Number: <b>WO 98/41258</b></p> <p>(43) International Publication Date: 24 September 1998 (24.09.98)</p>
<p>(21) International Application Number: PCT/SE98/00459</p> <p>(22) International Filing Date: 13 March 1998 (13.03.98)</p> <p>(30) Priority Data: 9700939-3                      14 March 1997 (14.03.97)                      SE</p> <p>(71) Applicant (for all designated States except US): ASTRA AKTIEBOLAG (publ) [SE/SE]; S-151 85 Södertälje (SE).</p> <p>(72) Inventors; and (75) Inventors/Applicants (for US only): DAGSLAND, Allan [SE/SE]; Musseronvägen 13, S-374 40 Karlshamn (SE). VIRTANEN, Risto [FI/FI]; Torenvägen 10C, FIN-01900 Nurmijärvi (FI).</p> <p>(74) Agent: ASTRA AKTIEBOLAG; Patent Dept., S-151 85 Södertälje (SE).</p>		<p>(81) Designated States: AL, AM, AT, AU, AZ, BA, BB, BG, BR, BY, CA, CH, CN, CU, CZ, DE, DK, EE, ES, FI, GB, GE, GH, GM, GW, HU, ID, IL, IS, JP, KE, KG, KP, KR, KZ, LC, LK, LR, LS, LT, LU, LV, MD, MG, MK, MN, MW, MX, NO, NZ, PL, PT, RO, RU, SD, SE, SG, SI, SK, SL, TJ, TM, TR, TT, UA, UG, US, UZ, VN, YU, ZW, ARIPO patent (GH, GM, KE, LS, MW, SD, SZ, UG, ZW), Eurasian patent (AM, AZ, BY, KG, KZ, MD, RU, TJ, TM), European patent (AT, BE, CH, DE, DK, ES, FI, FR, GB, GR, IE, IT, LU, MC, NL, PT, SE), OAPI patent (BF, BJ, CF, CG, CI, CM, GA, GN, ML, MR, NE, SN, TD, TG).</p> <p><b>Published</b> <i>With international search report. Before the expiration of the time limit for amending the claims and to be republished in the event of the receipt of amendments.</i></p>

(54) Title: INHALATION DEVICE

(57) Abstract

A powder inhaler and a method of constructing the same, the powder inhaler comprising: an inhaler body (6) having an opening (10) therein; an inhalation unit (22) disposed in the inhaler body (6), the inhalation unit (22) comprising an inhalation channel (24) through which powder is in use inhaled; a dosing unit (16) for providing a dose of powder to the inhalation channel (24) disposed in the inhaler body (6) so as to be rotatable about the central axis thereof, wherein the dosing unit (16) comprises a central shaft (20) which is co-axial with the central axis of the inhaler body (6) and has a spiral groove or protrusion (46) on the end face thereof; and an indicating wheel (42) for providing an indication as to the usage of the inhaler disposed in the inhaler body (6), the indicating wheel (42) having a toothed periphery (44) for engaging the spiral groove or protrusion (46) on the shaft (20) and being disposed such that at least a part thereof is visible through the opening (10) and so as to be rotatable within a diametrical plane containing the central axis of the inhaler body (6); characterized in that one side surface of the indicating wheel (42) includes at least one indication which is representative of the usage of the inhaler and in that the inhaler body (6) includes a recess (48) in which the opening (10) is provided, the opening (10) allowing at least a part of the one side surface of the indicating wheel (42) to be viewed.

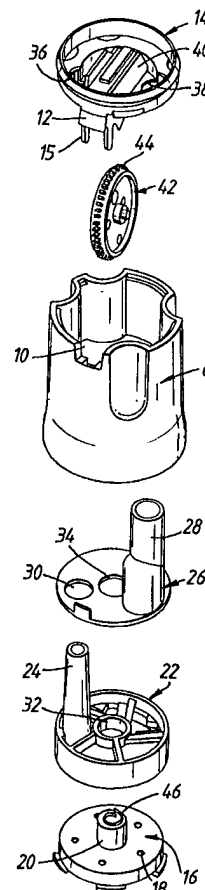

**FOR THE PURPOSES OF INFORMATION ONLY**

Codes used to identify States party to the PCT on the front pages of pamphlets publishing international applications under the PCT.

AL	Albania	ES	Spain	LS	Lesotho	SI	Slovenia
AM	Armenia	FI	Finland	LT	Lithuania	SK	Slovakia
AT	Austria	FR	France	LU	Luxembourg	SN	Senegal
AU	Australia	GA	Gabon	LV	Latvia	SZ	Swaziland
AZ	Azerbaijan	GB	United Kingdom	MC	Monaco	TD	Chad
BA	Bosnia and Herzegovina	GE	Georgia	MD	Republic of Moldova	TG	Togo
BB	Barbados	GH	Ghana	MG	Madagascar	TJ	Tajikistan
BE	Belgium	GN	Guinea	MK	The former Yugoslav Republic of Macedonia	TM	Turkmenistan
BF	Burkina Faso	GR	Greece			TR	Turkey
BG	Bulgaria	HU	Hungary	ML	Mali	TT	Trinidad and Tobago
BJ	Benin	IE	Ireland	MN	Mongolia	UA	Ukraine
BR	Brazil	IL	Israel	MR	Mauritania	UG	Uganda
BY	Belarus	IS	Iceland	MW	Malawi	US	United States of America
CA	Canada	IT	Italy	MX	Mexico	UZ	Uzbekistan
CF	Central African Republic	JP	Japan	NE	Niger	VN	Viet Nam
CG	Congo	KE	Kenya	NL	Netherlands	YU	Yugoslavia
CH	Switzerland	KG	Kyrgyzstan	NO	Norway	ZW	Zimbabwe
CI	Côte d'Ivoire	KP	Democratic People's Republic of Korea	NZ	New Zealand		
CM	Cameroon			PL	Poland		
CN	China	KR	Republic of Korea	PT	Portugal		
CU	Cuba	KZ	Kazakstan	RO	Romania		
CZ	Czech Republic	LC	Saint Lucia	RU	Russian Federation		
DE	Germany	LI	Liechtenstein	SD	Sudan		
DK	Denmark	LK	Sri Lanka	SE	Sweden		
EE	Estonia	LR	Liberia	SG	Singapore		

## INHALATION DEVICE

The present invention relates to a powder inhaler and a method of constructing the same.

5 A number of powder inhalers are known which use different systems for introducing a dose of powder into an air stream. Typically, the powder is inhaled into the lungs of a patient in order to treat, for example, asthma.

One such powder inhaler is disclosed in EP-A-0237507. This inhaler includes a flow path,  
10 which comprises an inhalation channel and a mouthpiece comprising an air chamber and an outlet nozzle, through which a stream of air is drawn during inhalation by a user, and means for introducing powder into the inhalation channel. During inhalation, air is first drawn into and through the inhalation channel so as to pick up powder. The stream of air containing powder is then drawn through the air chamber and out of the outlet nozzle of the  
15 mouthpiece.

Figure 1 illustrates such a powder inhaler. The inhaler comprises a mouthpiece 2 comprising an air chamber (not illustrated) and an outlet nozzle 4, an inhaler body 6 and a rotatable grip portion 8 for operating a dosing mechanism for providing doses of powder  
20 for inhalation. The inhaler body 6 includes an opening 10 which is filled with a window 12 through which an indicating wheel 42 is visible so as to provide an indication as to the usage of the inhaler.

Figure 2 illustrates in exploded view component parts disposed within and to the inhaler  
25 body 6. The inhaler body 6 is capped with a divider 14 which is fixed thereto and separates the air chamber in the mouthpiece 2 from a major part of the inhaler body 6. For aesthetic reasons the inhaler body 6 is an opaque moulding. The divider 14 is a transparent moulding which has a depending tongue 15, a part of which forms the window 12. When the inhaler is assembled, the only part of the divider 14 which is visible is the part of the

tongue 15 forming the window 12, and thus the overall appearance of the inhaler is unaffected.

Within the inhaler body 6 are housed the component parts of the dosing mechanism. These component parts include a dosing unit 16 which comprises a plurality of dosing means 18 and a central axial shaft 20, an inhalation unit 22 which comprises an inhalation channel 24 and a storage unit 26 which comprises a storage chamber 28 for storing powder. The above-mentioned component parts of the dosing mechanism are assembled by passing the inhalation channel 24 through an opening 30 in the storage unit 26 and passing the shaft 20 through central openings 32, 34 in the inhalation unit 22 and the storage unit 26 respectively. When so assembled, the upper ends of the inhalation channel 24 and the storage chamber 28 pass respectively through first and second openings 36, 38 in the divider 14.

In use, powder is transferred from the storage chamber 28 to one of the dosing means 18, and, with rotation of the dosing unit 16, the one dosing means 18 provides a dose of powder to the inhalation channel 24. On inhalation by a user the powder is drawn up through the air chamber and out of the outlet nozzle 4 of the mouthpiece 2.

As illustrated in Figures 2 and 3, the divider 14 further comprises supporting means 40 for rotatably supporting an indicating wheel 42. The indicating wheel 42 has a plurality of teeth 44 disposed around the periphery thereof which engage with a spiral groove or protrusion 46 on the end face of the shaft 20 of the dosing unit 16. The supporting means 40 is configured to align the indicating wheel 42 such that a part of the periphery thereof is disposed adjacent the inner surface of the window 12.

In use, as the dosing unit 16 is rotated, the spiral groove or protrusion 46 engages with one or more of the teeth 44 on the indicating wheel 42 so as to rotate the same. In this way, by providing a coloured marking on the periphery of the indicating wheel 42, it is possible to provide the user with a visible indication at the window 12 as to the usage of the inhaler.

Whilst the above-described known powder inhaler functions quite adequately, it is an aim of the present invention to provide a powder inhaler which more visibly indicates the usage of the inhaler. It is a further aim of the present invention to provide a powder inhaler  
5 having fewer components and hence reduced manufacturing complexity.

Accordingly, the present invention provides a powder inhaler, comprising: an inhaler body having an opening therein; an inhalation unit disposed in the inhaler body, the inhalation unit comprising an inhalation channel through which powder is in use inhaled; a dosing  
10 unit for providing a dose of powder to the inhalation channel disposed in the inhaler body so as to be rotatable about the central axis thereof, wherein the dosing unit comprises a central shaft which is co-axial with the central axis of the inhaler body and has a spiral groove or protrusion on the end face thereof; and an indicating wheel for providing an indication as to the usage of the inhaler disposed in the inhaler body, the indicating wheel  
15 having a toothed periphery for engaging the spiral groove or protrusion on the shaft and being disposed such that at least a part thereof is visible through the opening and so as to be rotatable within a diametrical plane containing the central axis of the inhaler body; characterized in that one side surface of the indicating wheel includes at least one indication which is representative of the usage of the inhaler and in that the inhaler body  
20 includes a recess in which the opening is provided, the opening allowing at least a part of the one side surface of the indicating wheel to be viewed.

Preferably, the inhaler further comprises a storage unit disposed in the inhaler body, the storage unit comprising a storage chamber for storing powder.  
25

More preferably, the storage unit is formed of a transparent material and the inhaler further comprises a portion which substantially fills the opening.

Preferably, the inhalation unit and the storage unit are formed as a single integral unit.  
30

Preferably, the inhaler further comprises a divider substantially closing one end of the inhaler body.

More preferably, the recess comprises first and second opposing surfaces which are substantially parallel to the major surface of the divider and at least first and second side surfaces joining the first and second opposing surfaces, the opening being formed in one of the side surfaces.

Preferably, the inhaler body and the divider are formed as a single integral unit.

10

In one embodiment the storage unit further comprises supporting means for rotatably supporting the indicating wheel.

15

In another embodiment the divider comprises supporting means for rotatably supporting the indicating wheel.

Preferably, the inhaler body further comprises an air inlet in a side wall thereof, the air inlet allowing air to be drawn to the dosing unit and through the inhalation channel.

20

More preferably, the air inlet is provided in the recess.

Preferably, the inhaler body is substantially cylindrical.

25

Preferably, the one side surface of the indicating wheel includes numerals indicating the number of doses administered and/or remaining.

Preferably, the one side surface of the indicating wheel includes an at least part circular band of varying width indicating the number of doses administered and/or remaining.

The present invention also provides a method of constructing an inhaler for administering powder by inhalation, comprising the steps of: providing an inhaler body having an opening therein; fitting an inhalation unit comprising an inhalation channel through which powder is in use inhaled in the inhaler body; fitting a dosing unit for providing a dose of powder to the inhalation channel in the inhaler body so as to be rotatable about the central axis thereof, wherein the dosing unit comprises a central shaft which is co-axial with the central axis of the inhaler body and has a spiral groove or protrusion on the end face thereof; and fitting an indicating wheel having a toothed periphery in the inhaler body in such a manner that the toothed periphery engages the spiral groove or protrusion on the shaft and so as to be rotatable in a diametrical plane containing the central axis of the inhaler body, wherein at least a part of the indicating wheel is visible through the opening so as to provide an indication as to the usage of the inhaler; characterized in that the method further comprises the steps of providing one side surface of the indicating wheel with at least one indication which is representative of the usage of the inhaler and providing the inhaler body with a recess in which the opening is provided, the opening allowing at least a part of the one side surface of the indicating wheel to be viewed.

Preferably, the step of providing an inhaler body comprises the step of providing as a single integral unit an inhaler body with a divider substantially closing one end thereof.

Medicaments suitable for administration by the powder inhaler of the present invention are any which may be delivered by inhalation and include for example  $\beta$ 2-adrenoreceptor agonists, for example, salbutamol, terbutaline, rimiterol, fenoterol, reproterol, adrenaline, pirbuterol, isoprenaline, orciprenaline, bitolterol, salmeterol, formoterol, clenbuterol, procaterol, broxaterol, picumeterol, TA-2005, mabuterol and the like, and their pharmacologically acceptable esters and salts; anticholinergic bronchodilators, for example, ipratropium bromide and the like; glucocorticosteroids, for example, beclomethasone, fluticasone, budesonide, tipredane, dexamethasone, betamethasone, fluocinolone, triamcinolone acetonide, mometasone and the like, and their

pharmacologically acceptable esters and salts; antiallergic medicaments, for example, sodium cromoglycate and nedocromil sodium; expectorants; mucolytics; antihistamines; cyclooxygenase inhibitors; leukotriene synthesis inhibitors; leukotriene antagonists; phospholipase-A2 (PLA2) inhibitors; platelet aggregating factor (PAF) antagonists and prophylactics of asthma; antiarrhythmic medicaments; tranquilisers; cardiac glycosides; hormones; antihypertensive medicaments; antidiabetic medicaments; antiparasitic medicaments; anticancer medicaments; sedatives; analgesic medicaments; antibiotics; antirheumatic medicaments; immunotherapies; antifungal medicaments; antihypotension medicaments; vaccines; antiviral medicaments; proteins; polypeptides and peptides, for example, peptide hormones and growth factors; polypeptide vaccines; enzymes; endorphines; lipoproteins and polypeptides involved in the blood coagulation cascade; vitamins; and others, for example, cell surface receptor blockers, antioxidants, free radical scavengers and organic salts of N,N'-diacetylcystine.

Preferred embodiments of the present invention will now be described hereinbelow by way of example only with reference to the accompany drawings, in which:

Figure 1 illustrates a perspective view of a known powder inhaler;

Figure 2 illustrates in exploded view component parts of the inhaler of Figure 1;

Figure 3 illustrates component parts of the inhaler of Figure 1;

Figure 4 illustrates a perspective view of a powder inhaler in accordance with a first embodiment of the present invention;

Figures 5 and 6 illustrate indicating wheels for use with the powder inhaler of Figure 4;



Figure 7 illustrates in exploded view component parts of a powder inhaler in accordance with a second embodiment of the present invention;

Figure 8 illustrates in exploded view component parts of a powder inhaler in accordance  
5 with a third embodiment of the present invention;

Figures 9 and 10 illustrate component parts of a powder inhaler in accordance with a fourth embodiment of the present invention;

10 Figure 11 illustrates a component part of a powder inhaler in accordance with a fifth embodiment of the present invention;

Figures 12 and 13 illustrate component parts of a powder inhaler in accordance with a sixth embodiment of the present invention; and

15

Figures 14 and 15 illustrate component parts of a powder inhaler in accordance with a seventh embodiment of the present invention.

Structurally, the powder inhalers in accordance with the preferred embodiments of the  
20 present invention have many features in common with the above-described known powder inhaler. For this reason, and in order to avoid unnecessary duplication of description, only the structural differences will be described in detail and reference is made to the preceding description of the known powder inhaler.

25 Figure 4 illustrates a powder inhaler in accordance with a first embodiment of the present invention.

This inhaler is a modification of the above-described known powder inhaler. This inhaler differs from the above-described known powder inhaler in that the inhaler body 6 includes  
30 a recess 48 in a side surface of which is provided the opening 10, which recess 48 is

located such that the opening 10 is adjacent one of the side surfaces of the indicating wheel 42, and in that the side surface of the indicating wheel 42 adjacent the opening 10 includes an indication or indications representative of the usage of the inhaler. As in the above-described known powder inhaler, the indicating wheel 42 is rotatably supported to the underside of the divider 14. In a preferred embodiment one or both of the inhalation unit 5 22 and the storage unit 26 are formed together with the inhaler body 6 as a single integral unit.

In one embodiment the indicating wheel 42 can be provided with numeric indications of increasing or decreasing value, for indicating the number of times the inhaler has been 10 operated or the number of times the inhaler may still be operated. In another embodiment the indicating wheel 42 may alternatively, or additionally, be provided with a circumferential band of changing width along its length, such that the width visible through the window 12 is representative of the number of doses delivered. Colour changes may 15 also be used to indicate the number of doses delivered or remaining. Such colour changes may be applied in conjunction with the indications described hereinabove. For instance, by using numerals of different colour, or by using a band, the colour of which changes along its length. In a preferred embodiment, in order to assist viewing, the side surface of the indicating wheel 42 adjacent the window 12 can be formed as a conical surface, with the 20 surface of the cone enclosing an angle of from  $10^\circ$  to  $30^\circ$ , preferably about  $15^\circ$ , with the rotational plane of the indicating wheel 42. Figures 5 and 6 illustrate preferred indicating wheels 42.

In this embodiment the recess 48 is configured such that the side surface thereof in which 25 the opening 10 is provided is parallel to the adjacent side surface of the indicating wheel 42. It will be appreciated, however, that, for the purposes of viewing the indicating wheel 42, it is sufficient that the opening 10 has a radial component. It will also be appreciated that the recess 48 can have any shape which allows a user to view the adjacent side surface of the indicating wheel 42 through the opening 10.

Figure 7 illustrates in exploded view component parts disposed within and to the inhaler body 6 of a powder inhaler in accordance with a second embodiment of the present invention.

5 This inhaler is a modification of the inhaler of the above-described first embodiment. This inhaler differs from the inhaler of the above-described first embodiment in that the recess 48 in the inhaler body 6 is of different shape. In this embodiment the recess 48 is of triangular cross-section. It will be noted, however, that in common with the inhaler of the above-described first embodiment the opening 10 in the recess 48 has a radial component.

10 This inhaler further differs from the inhaler of the above-described first embodiment in that the divider 14 does not include a depending tongue 15, but rather the storage unit 26 is formed from a transparent material and comprises an upstanding tongue 50, one part, in this embodiment the distal end, of which is shaped and dimensioned so as to provide the window 12 and fill the opening 10 when the storage unit 26 is fitted in the inhaler body 6.

15

Figure 8 illustrates in exploded view component parts disposed within and to the inhaler body 6 of a powder inhaler in accordance with a third embodiment of the present invention.

This inhaler is a modification of the inhaler of the above-described first embodiment. This inhaler differs from the inhaler of the above-described first embodiment in that the recess 48 in the inhaler body 6 is of different shape. In this embodiment the recess 48 is, similarly to the recess 48 of the above-described second embodiment, of triangular cross-section. It will be noted, however, that again in common with the inhaler body 6 of the above-described first embodiment the opening 10 in the recess 48 has a radial component. This inhaler further differs from the above-described first embodiment in that the tongue 15 depending from the divider 14 is oriented substantially radially as opposed to circularly so as to align with the opening 10 in the recess 48. Again, as in the above-described known powder inhaler, the indicating wheel 42 is rotatably supported to the underside of the divider 14.

30

Figures 9 and 10 illustrate respectively a body part 52 and a storage unit 26 of a powder inhaler in accordance with a fourth embodiment of the present invention.

This inhaler is a modification of the inhaler of the above-described first embodiment. This inhaler differs from the inhaler of the above-described first embodiment in comprising a  
5 body part 52 which is a single part moulded from an opaque material that comprises both the inhaler body 6 and the divider 14. This inhaler further differs from the inhaler of the above-described first embodiment in that the divider 14 does not include a depending tongue 15, but rather the storage unit 26 is formed from a transparent material and  
10 comprises an upstanding tongue 50, one part, in this embodiment the distal end, of which is shaped and dimensioned so as to provide the window 12 and fill the opening 10 when the storage unit 26 is fitted in the inhaler body 6. As in the above-described known powder inhaler, the indicating wheel 42 is rotatably supported to the underside of the divider 14.

15 Figure 11 illustrates a structural unit 54 of a powder inhaler in accordance with a fifth embodiment of the present invention.

This inhaler is a modification of the inhaler of the above-described fourth embodiment. This inhaler differs from the inhaler of the above-described fourth embodiment in  
20 comprising a structural unit 54 which is a single part moulded from a transparent material and combines both the inhalation unit 22 and the storage unit 26.

Figures 12 and 13 illustrate respectively a body part 52 and a structural unit 54 of a powder inhaler in accordance with a sixth embodiment of the present invention.

25

This inhaler is a modification of the inhaler of the above-described fifth embodiment. In this embodiment the body part 52 differs in that a lower section of the recess 48 in the inhaler body 6 is cut away to provide an opening 56 into the inhaler body 6 and in that the lower end of the inhalation channel 24 is provided with a lateral opening 58. During  
30 inhalation by a user, air is drawn through the opening 56 in the recess 48 and then the

opening 58 in the inhalation channel 24 where a dose of powder is entrained, which powder is then drawn up the inhalation channel 24 into and through the air chamber and out of the outlet nozzle 4 of the mouthpiece 2.

5 Figures 14 and 15 illustrate respectively a body part 52 and a structural unit 54 of a powder inhaler in accordance with a seventh embodiment of the present invention.

This inhaler is a modification of the inhaler of the above-described sixth embodiment.

10 This inhaler differs from the inhaler of the above-described sixth embodiment in that the structural unit 54 includes the supporting means 40 for rotatably supporting the indicating wheel 42 instead of the divider 14 and in that the divider 14 is formed with a substantially flat top surface. In this way, the risk of powder accumulating at this top surface is minimized. This is of particular importance where the top surface of the divider 14 forms the lower wall of the air chamber of the mouthpiece 2.

15

In each of the inhalers of the above-described fourth to seventh embodiments the storage chamber 28 is crescent-shaped in plan view and thereby provides an increased storage capacity. It will be understood, however, that the storage chamber 28 may be formed as a cylinder as in the above-described known powder inhaler.

20

Finally, it will be understood by a person skilled in the art that the present invention is not limited to the described embodiments but can be modified in many different ways within the scope of the appended claims.

## CLAIMS

1. A powder inhaler for administering powder by inhalation, comprising:
  - an inhaler body (6) having an opening (10) therein;
  - 5 an inhalation unit (22) disposed in the inhaler body (6), the inhalation unit (22) comprising an inhalation channel (24) through which powder is in use inhaled;
  - a dosing unit (16) for providing a dose of powder to the inhalation channel (24) disposed in the inhaler body (6) so as to be rotatable about the central axis thereof, wherein the dosing unit (16) comprises a central shaft (20) which is co-axial with the
  - 10 central axis of the inhaler body (6) and has a spiral groove or protrusion (46) on the end face thereof; and
  - an indicating wheel (42) for providing an indication as to the usage of the inhaler disposed in the inhaler body (6), the indicating wheel (42) having a toothed periphery (44) for engaging the spiral groove or protrusion (46) on the shaft (20) and being
  - 15 disposed such that at least a part thereof is visible through the opening (10) and so as to be rotatable within a diametrical plane containing the central axis of the inhaler body (6);
  - characterized in that one side surface of the indicating wheel (42) includes at least one indication which is representative of the usage of the inhaler and in that the inhaler body
  - 20 (6) includes a recess (48) in which the opening (10) is provided, the opening (10) allowing at least a part of the one side surface of the indicating wheel (42) to be viewed.
2. The inhaler according to claim 1, further comprising a storage unit (26) disposed in the inhaler body (6), the storage unit (26) comprising a storage chamber (28) for storing
- 25 powder.
3. The inhaler according to claim 2, wherein the storage unit (26) is formed of a transparent material and further comprises a portion (12) which substantially fills the opening (10).

4. The inhaler according to claim 2 or 3, wherein the inhalation unit (22) and the storage unit (26) are formed as a single integral unit.
5. The inhaler according to any of claims 1 to 4, further comprising a divider (14) substantially closing one end of the inhaler body (6).
6. The inhaler according to claim 5, wherein the recess (48) comprises first and second opposing surfaces which are substantially parallel to the major surface of the divider (14) and at least first and second side surfaces joining the first and second opposing surfaces, the opening (10) being formed in one of the side surfaces.
7. The inhaler according to claim 5 or 6, wherein the inhaler body (6) and the divider (14) are formed as a single integral unit.
8. The inhaler according to any of claims 2 to 7, wherein the storage unit (26) further comprises supporting means (40) for rotatably supporting the indicating wheel (42).
9. The inhaler according to any of claims 5 to 7, wherein the divider (14) comprises supporting means (40) for rotatably supporting the indicating wheel (42).
10. The inhaler according to any of claims 1 to 9, wherein the inhaler body (6) further comprises an air inlet (56) in a side wall thereof, the air inlet (56) allowing air to be drawn to the dosing unit (16) and through the inhalation channel (24).
11. The inhaler according to claim 10, wherein the air inlet (56) is provided in the recess (48).
12. The inhaler according to any of claims 1 to 11, wherein the inhaler body (6) is substantially cylindrical.

13. The inhaler according to any of claims 1 to 12, wherein the one side surface of the indicating wheel (42) includes numerals indicating the number of doses administered and/or remaining.
- 5 14. The inhaler according to any of claims 1 to 13, wherein the one side surface of the indicating wheel (42) includes an at least part circular band of varying width indicating the number of doses administered and/or remaining.
15. A method of constructing an inhaler for administering powder by inhalation,  
10 comprising the steps of:  
providing an inhaler body (6) having an opening (10) therein;  
fitting an inhalation unit (22) comprising an inhalation channel (24) through which powder is in use inhaled in the inhaler body (6);  
fitting a dosing unit (16) for providing a dose of powder to the inhalation channel (24) in  
15 the inhaler body (6) so as to be rotatable about the central axis thereof, wherein the dosing unit (16) comprises a central shaft (20) which is co-axial with the central axis of the inhaler body (6) and has a spiral groove or protrusion (46) on the end face thereof;  
and  
fitting an indicating wheel (42) having a toothed periphery (44) in the inhaler body (6) in  
20 such a manner that the toothed periphery (44) engages the spiral groove or protrusion (46) on the shaft (20) and so as to be rotatable in a diametrical plane containing the central axis of the inhaler body (6), wherein at least a part of the indicating wheel (42) is visible through the opening (10) so as to provide an indication as to the usage of the inhaler;
- 25 characterized in that the method further comprises the steps of providing one side surface of the indicating wheel (42) with at least one indication which is representative of the usage of the inhaler and providing the inhaler body (6) with a recess (48) in which the opening (10) is provided, the opening (10) allowing at least a part of the one side surface of the indicating wheel (42) to be viewed.



16. The method according to claim 15, wherein the step of providing an inhaler body (6) comprises the step of providing as a single integral unit an inhaler body (6) with a divider (14) substantially closing one end thereof.

1/7

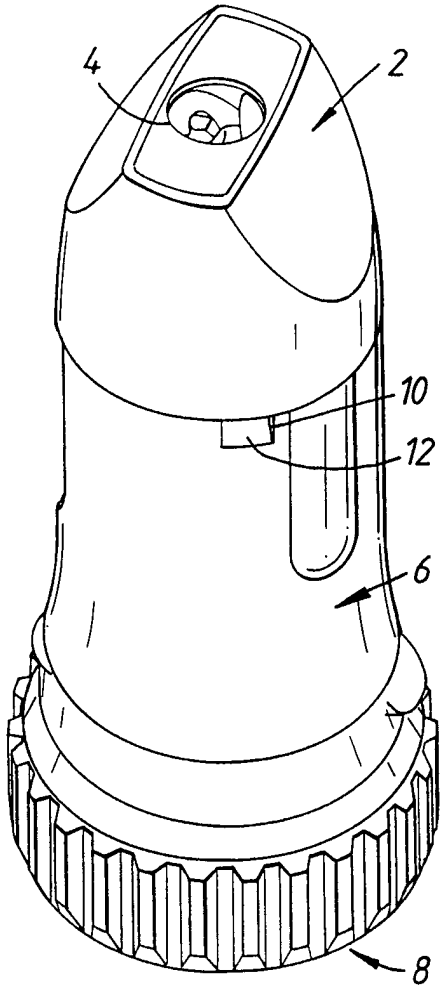

Fig. 1

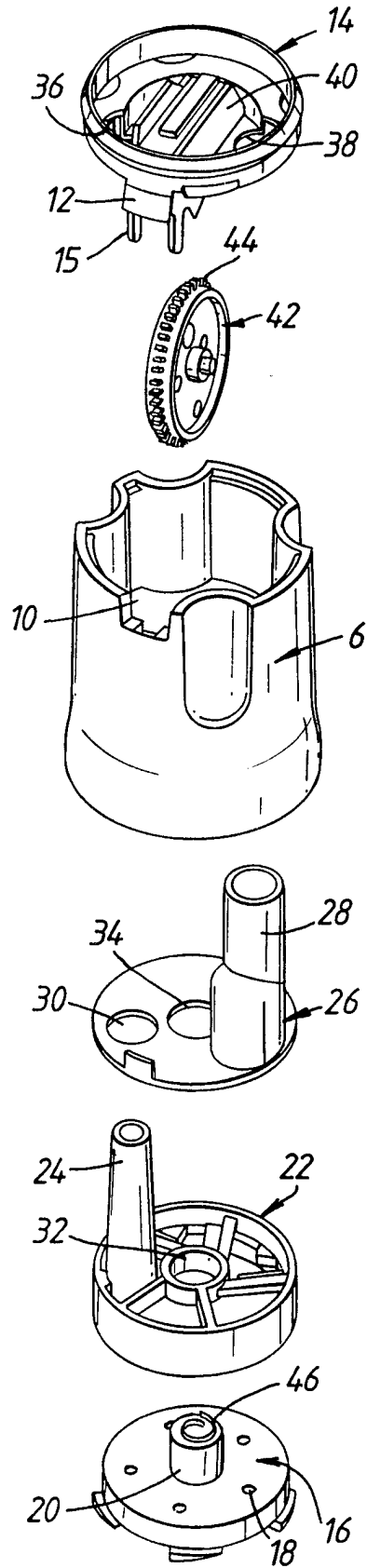

Fig. 2

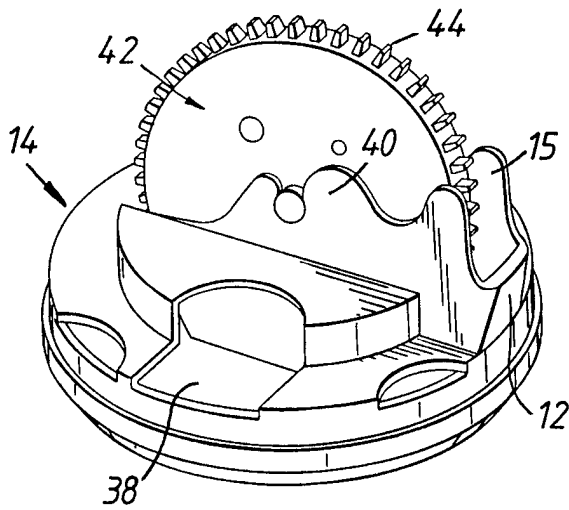

Fig. 3

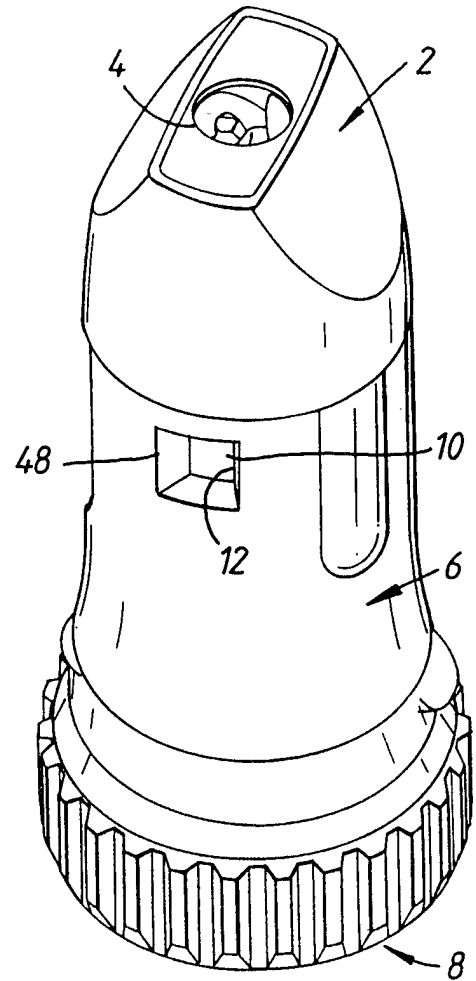

Fig. 4

3/7

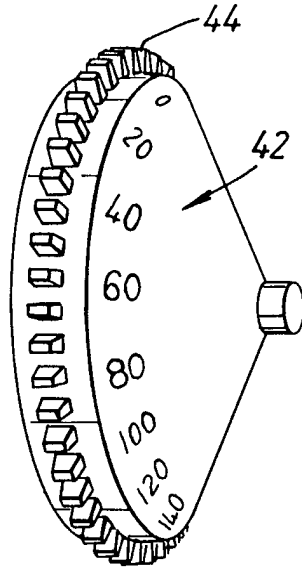

Fig. 5

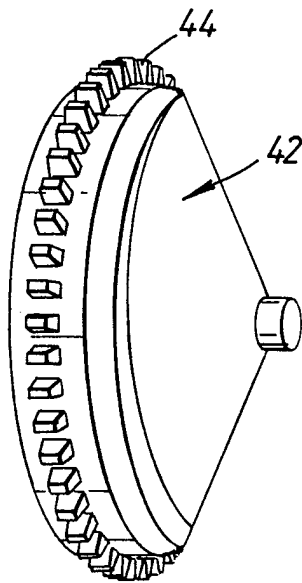
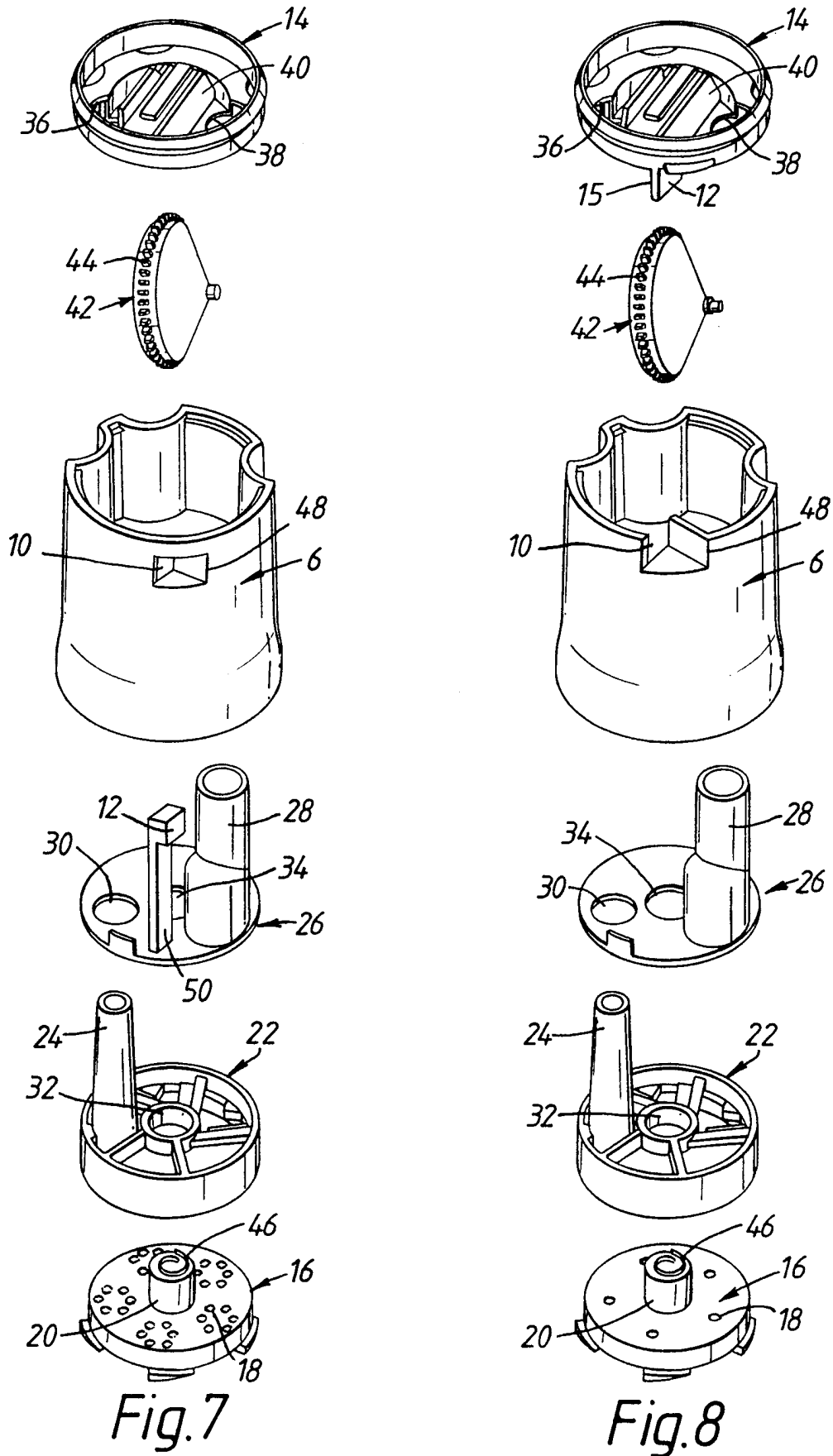

Fig. 6

4/7



5/7

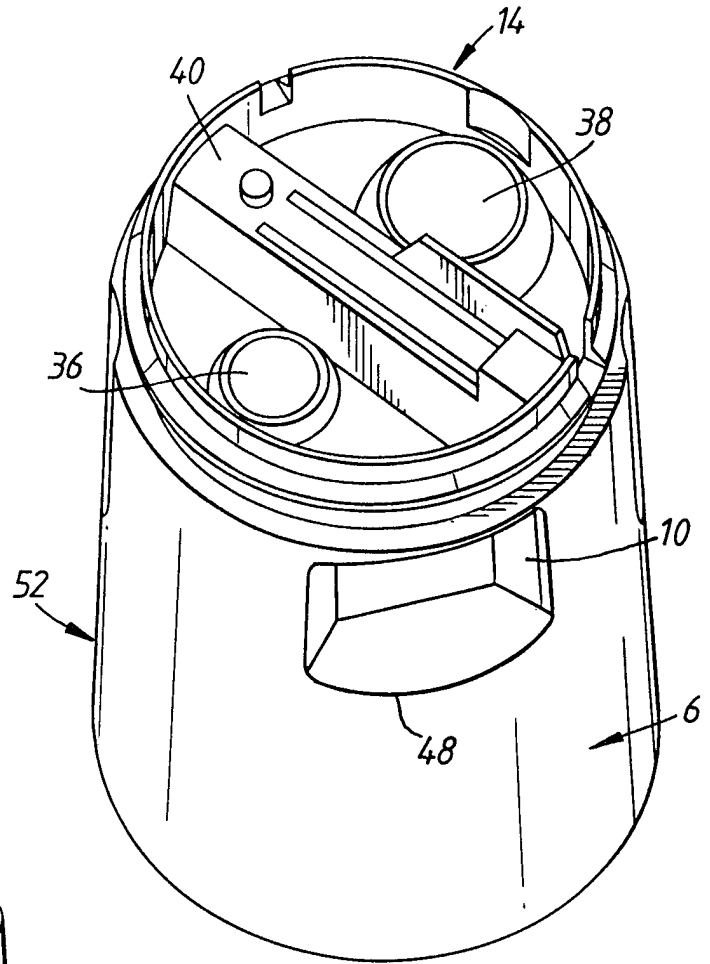

Fig. 9

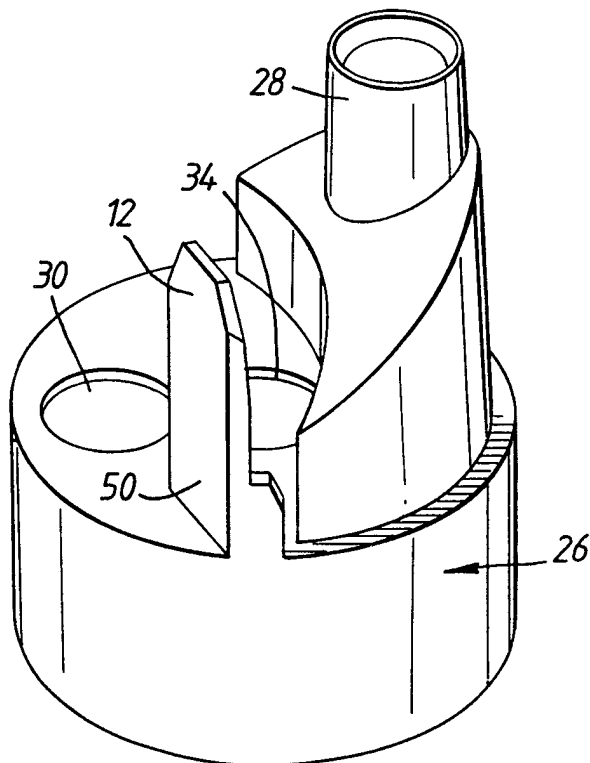

Fig. 10

6/7

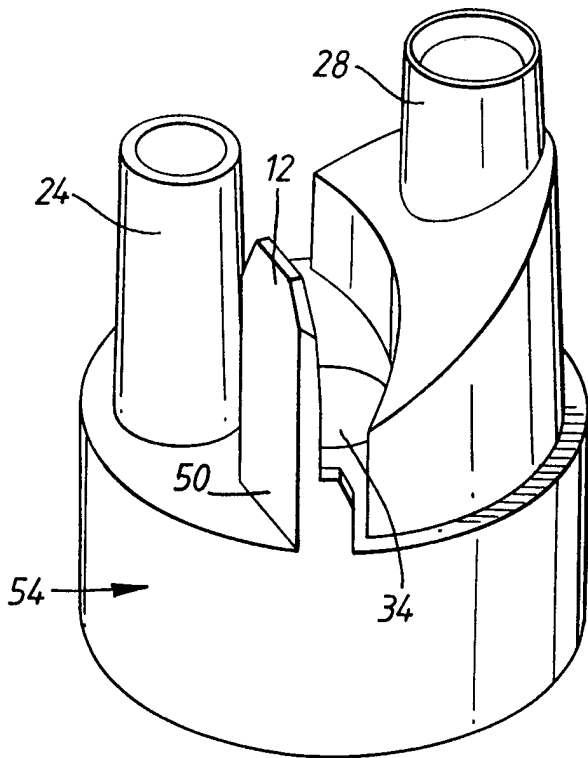

Fig. 11

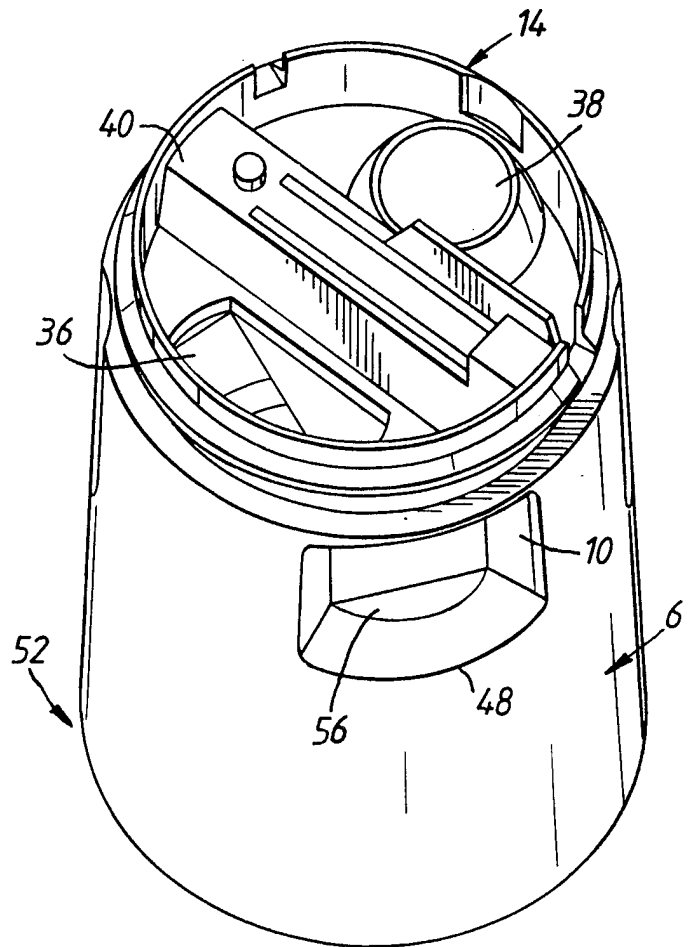

Fig. 12

7/7

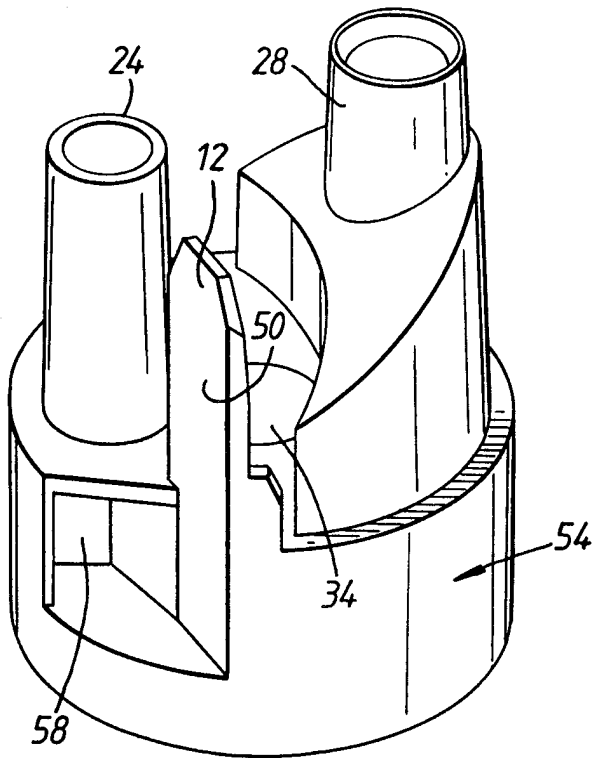

Fig. 13

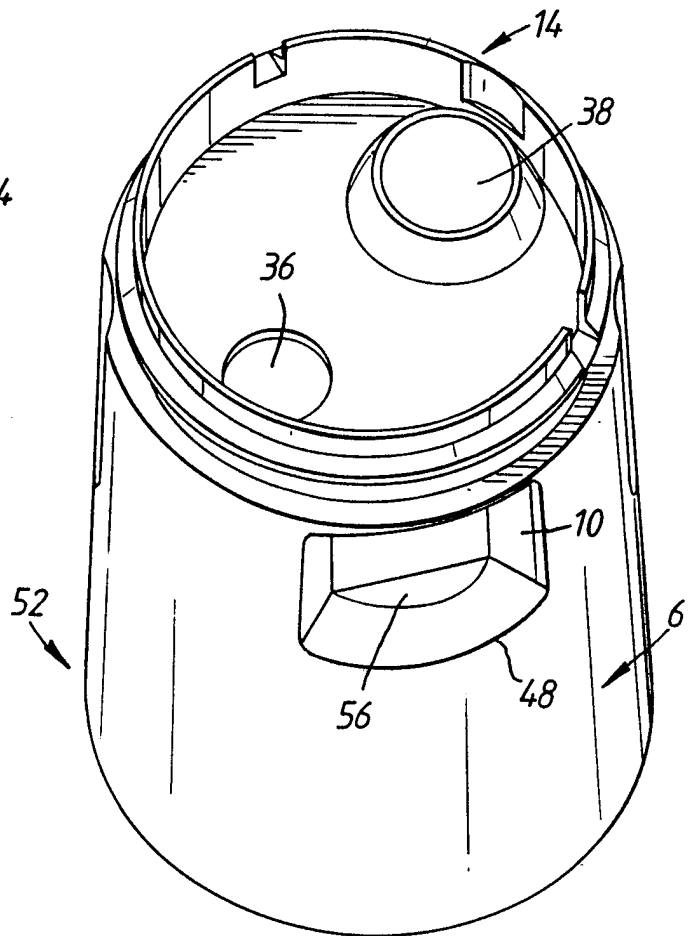

Fig. 14

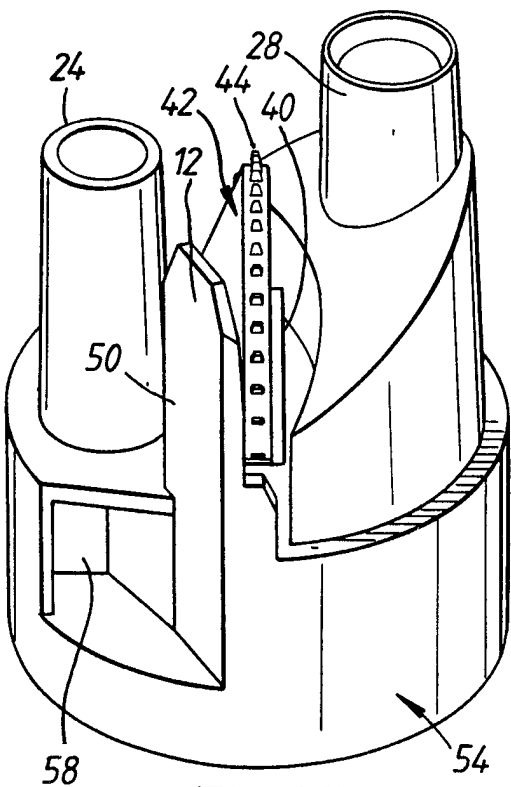

Fig. 15



# INTERNATIONAL SEARCH REPORT

International Application No  
PCT/SE 98/00459

**A. CLASSIFICATION OF SUBJECT MATTER**  
IPC 6 A61M15/00

According to International Patent Classification (IPC) or to both national classification and IPC

**B. FIELDS SEARCHED**

Minimum documentation searched (classification system followed by classification symbols)  
IPC 6 A61M

Documentation searched other than minimum documentation to the extent that such documents are included in the fields searched

Electronic data base consulted during the international search (name of data base and, where practical, search terms used)

**C. DOCUMENTS CONSIDERED TO BE RELEVANT**

Category	Citation of document, with indication, where appropriate, of the relevant passages	Relevant to claim No.
X A	WO 86 05991 A (DRACO AB) 23 October 1986 see page 4, line 4 - page 5, line 11; figures 1-5	1, 2, 5, 12 15
A	----- WO 94 14492 A (AMBROSIO THOMAS J ; MANTHENA SRINIVAS (US); SCHERING CORP (US); WIL) 7 July 1994 see abstract; figures 1-4 -----	1, 15

Further documents are listed in the continuation of box C.

Patent family members are listed in annex.

Special categories of cited documents :

- "A" document defining the general state of the art which is not considered to be of particular relevance
- "E" earlier document but published on or after the international filing date
- "L" document which may throw doubts on priority claim(s) or which is cited to establish the publication date of another citation or other special reason (as specified)
- "O" document referring to an oral disclosure, use, exhibition or other means
- "P" document published prior to the international filing date but later than the priority date claimed

- "T" later document published after the international filing date or priority date and not in conflict with the application but cited to understand the principle or theory underlying the invention
- "X" document of particular relevance; the claimed invention cannot be considered novel or cannot be considered to involve an inventive step when the document is taken alone
- "Y" document of particular relevance; the claimed invention cannot be considered to involve an inventive step when the document is combined with one or more other such documents, such combination being obvious to a person skilled in the art.
- "&" document member of the same patent family

Date of the actual completion of the international search

31 July 1998

Date of mailing of the international search report

11/08/1998

Name and mailing address of the ISA  
European Patent Office, P.B. 5818 Patentlaan 2  
NL - 2280 HV Rijswijk  
Tel. (+31-70) 340-2040, Tx. 31 651 epo nl,  
Fax: (+31-70) 340-3016

Authorized officer  
  
Jameson, P

## INTERNATIONAL SEARCH REPORT

International Application No

PCT/SE 98/00459

Patent document cited in search report	Publication date	Patent family member(s)	Publication date
WO 8605991    A	23-10-1986	SE 448277 B	09-02-1987
		AU 587460 B	17-08-1989
		AU 5771686 A	05-11-1986
		CA 1250503 A	28-02-1989
		DK 572686 A, B,	28-11-1986
		EP 0258238 A	09-03-1988
		FI 874460 A, B	09-10-1987
		JP 62502451 T	24-09-1987
		KR 9402248 B	19-03-1994
		PT 82375 B	30-11-1992
		SE 8501806 A	13-10-1986
		US 4668218 A	26-05-1987
		-----	
WO 9414492    A	07-07-1994	AU 683036 B	30-10-1997
		AU 5748794 A	19-07-1994
		CA 2152088 A	07-07-1994
		CN 1091321 A	31-08-1994
		CZ 9501535 A	15-05-1996
		EP 0674533 A	04-10-1995
		FI 952976 A	16-06-1995
		HU 73522 A	28-08-1996
		IL 108061 A	10-06-1997
		JP 8500756 T	30-01-1996
		NO 952429 A	18-08-1995
		NZ 259241 A	20-12-1996
		PL 309401 A	02-10-1995
		SK 80695 A	07-02-1996
		US 5687710 A	18-11-1997
US 5740792 A	21-04-1998		
ZA 9309472 A	19-06-1995		
-----			