

EUROPEAN PATENT APPLICATION

Application number: **83301586.0**

Int. Cl.³: **F 23 R 3/26**

Date of filing: **22.03.83**

Priority: **22.07.82 US 400580**
22.07.82 US 400578

Applicant: **THE GARRETT CORPORATION,**
9851-9951 Sepulveda Boulevard P.O. Box 92248, Los
Angeles, California 90009 (US)

Date of publication of application: **08.02.84**
Bulletin 84/6

Inventor: **Mongia, Hukam C., 1897 East Magdalena Drive,**
Tempe Arizona 85283 (US)
Inventor: **Coleman, Edwin B., 916, West Yale Drive,**
Tempe Arizona 85283 (US)
Inventor: **Bruce, Thomas W., 4509 East Ludlow Drive,**
Phoenix Arizona 85032 (US)
Inventor: **Elliot, Harry A., 3810 East Sahuaro Drive,**
Phoenix Arizona 85028 (US)
Inventor: **White, John T., 901, County Plaza East, Gilbert**
Arizona 85234 (US)

Designated Contracting States: **DE FR GB IT SE**

Representative: **Arthur, George Fitzgerald et al,**
KILBURN & STRODE 30, John Street, London WC1N 2DD
(GB)

54 Combustor.

57 This invention is a combustor for a gas turbine engine, particularly for aircraft propulsion, in which a combustion passage (54) is defined by a liner (44) within a housing (38) defining an inlet air plenum chamber (56) for air from a compressor. Normally fuel is injected through nozzles (24) in an annular end wall (46) of the liner and burnt using primary air received through inlets (88); additional air is provided through swirlers (84, 86) and by way of liner cooling passages (70, 72) both of which receive their air from a liner plenum (60) through an inlet (98). The inlet (98) can be progressively opened or closed by actuating means (Figure 8) so that the quantity of air in the swirlers and in the cooling passages can be controlled together. For re-ignition at altitude and possibly also for initial starting at ground level, a valve sleeve (96) can close the inlet (98) so that ignition is only in the primary air at (88), and simultaneously an inlet (92) for compressed air at a downstream part of the combustion passage (54) is opened so that that air is not wasted, but is fed into the burning gases for exit at (52) for supply to a turbine.

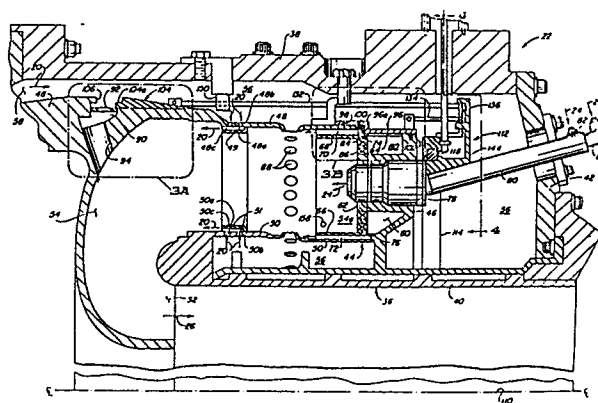

COMBUSTOR

The present invention relates generally to combustors for example for use in gas turbine propulsion engines, and one object of the invention is to provide for imparting significantly improved stability and

5. ignition performance to high-temperature rise combustors

Continuing evolution and improvements in combustor design have resulted in highly efficient fixed geometry combustors for conventional aircraft gas turbine propulsion engines. However, it is well

10. known that such conventional combustors have significant limitations and disadvantages when utilised in the propulsion engines of ultra-high performance

aircraft operating within expanded altitude-mach number flight envelopes. Among the more critical

15. of these recognised combustor deficiencies arising from flight envelope expansion are combustion instability, high altitude relight difficulties and ground ignition problems at low ambient temperatures.

According to the invention, a combustor includes

20. a liner defining a combustion passage and an inlet for air for the combustion passages and is characterised by means for controlling the passage of

air through the inlet and for controlling the entry of air to the combustion passage through two different

25. passages simultaneously.

In carrying out principles of the present invention, in accordance with a preferred embodiment thereof, a gas turbine propulsion engine may be provided with such a specially designed combustor

30. which is operable to significantly expand the altitude-mach number flight envelope within which the

engine may be operated without experiencing the combustor lean instability and relight problems associated with conventional fixed geometry combustors.

- In the preferred embodiment, the combustor
5. has a number of features any of which, or any combination of which is a feature of the invention. Thus, that combustor is of an annular, reverse flow configuration, having a hollow, annular combustor liner which is surrounded by an intake plenum that receives high
 10. pressure discharge air from the engine's compressor section. The combustor liner has an annular upstream end wall and an annular interior wall spaced therefrom in -----

3:
a downstream direction. Together with the annular liner sidewalls these axially spaced liner walls define within the liner interior an annular air inlet plenum which communicates with the main combustor intake plenum through a circumferentially spaced series of
5 liner slots positioned around the outer liner periphery between the upstream end wall and the interior wall of the liner.

Projecting axially inwardly through the liner end wall, the liner inlet plenum and the interior liner wall are a circumferentially spaced series of piloted, air blast fuel nozzles for
10 injecting fuel into a dome portion of the liner interior which extends downstream from the annular interior liner wall. Compressor discharge air entering the liner plenum through the slotted inlet openings is forced into the liner dome area through air swirler means carried by the interior wall and circumscribing each of the
15 fuel nozzles. A portion of this entering air is also forced axially through skirted cooling passages extending along the dome portion of the liner interior and communicating with the liner inlet plenum.

Immediately downstream from the liner dome portion are
20 a circumferentially spaced series of liner wall orifices for admitting primary combustion air into the liner interior. Further downstream are a circumferentially spaced series of aft end openings, formed through the radially outer liner sidewall, through which the liner interior and the main combustor intake
25 plenum communicate.

4.

To effectively vary the operation of the combustor, means are provided for selectively closing off the liner's slotted inlet plenum openings while permitting air inflow through the aft end openings, or closing off the aft end openings while permitting air inflow through the slotted lines inlet plenum openings. This ability to close off either the aft end openings or the liner plenum inlet openings affords the combustor substantially improved combustion stability and relight capabilities.

More specifically, during ground starts of the engine, the aft end openings are unblocked, the liner inlet plenum openings are closed off, and the nozzles are staged to their pilot fuel spray mode. The closure of the liner plenum inlet openings prevents inward airflow through the air swirlers and also prevents the flow of cooling air through the skirted cooling passages. This mode of operating the combustor, which is also utilized to effect high altitude relights of the combustor, simultaneously maximizes the fuel richness in the liner dome area and minimizes the heat transfer outwardly through the walls thereof. By effectively elevating both the dome area combustion temperature and the fuel richness in the dome, the operating range within which the combustion process within the combustor may be sustained, and rapidly and reliably initiated, is substantially expanded.

After startup of the engine is initiated in this manner, the engine is brought to within its normal power output range by unblocking the liner inlet openings and closing off the aft end openings - establishing both swirler air inflow and dome cooling airflow. Should the need arise for a high altitude restart of the

engine, the aft end and liner plenum inlet openings are respectively unblocked and closed off as previously described. During restart, instead of conventionally externally bleeding excess compressor discharge

5. air from the engine, such excess air is forced inwardly through the pressure balancing openings, outwardly through the combustor outlet, and across the turbine section of the engine to increase the "windmill" restarting forces thereon. Coupled with

10. the previously described dome swirler and cooling air control, this unique use of compressor bleed air further enhances the high altitude restart capabilities of the engine.

The invention includes a method of operating

15. a combustor in which the supply of air is controlled simultaneously through two inlets. There may be a swirl inlet and a combustor liner cooling air inlet at a combustion zone, or may be in inlet on a combustion zone and a downstream inlet, in which case

20. variation of the rate of supply of air will be in opposite series at the two inlets.

The invention may be carried into practice in various ways, and one embodiment will now be described by way of example with reference to the accompanying

25. drawings in which:-

FIGURE 1 is a greatly simplified schematic diagram of a gas turbine aircraft propulsion engine having a variable geometry combustor and associated actuation system which embody principles of the present

30. invention;

FIGURE 2 is a graph illustrating the expanded flight envelope in which the engine may be operated due to the substantially improved combustion stability and ignition capabilities of the combustor;

5. FIGURE 3 is a greatly enlarged cross-sectional view through area 3 of the combustor of FIGURE 1 with portions of the combustor interior details being omitted for illustrative clarity;

Fig. 3A is an enlarged view of area 3A of Fig. 3 and illustrates a first sealing valve member of the actuation system moved to its closed position.

Fig. 3B is an enlarged view of area 3B of Fig. 3 and illustrates a second sealing valve member of the actuation system moved to its open position;

Fig. 4 is a fragmentary cross-sectional view taken through the combustor along line 4-4 of Fig. 3;

Fig. 5 is an enlarged elevational view of a portion of the actuation system taken along line 5-5 of Figure 4;

Fig. 6 is a cross-sectional view through the actuation system taken along line 6-6 of Fig. 4;

Fig. 7 is an enlarged cross-sectional view through the actuation system taken along line 7-7 of Fig. 4; and

Fig. 8 is a fragmentary isometric illustration of a portion of the actuation system which schematically depicts the selective movement of various of its components.

DETAILED DESCRIPTION

Schematically illustrated in Fig. 1 are the primary components of a gas turbine propulsion engine 10 which embodies principles of the present invention. During operation of the engine, ambient air 12 is drawn into a compressor 14 which is spaced apart from and rotationally coupled to a bladed turbine

section 16 by an interconnecting shaft 18. Pressurized air 20 discharged from compressor 14 is forced into an annular, reverse flow combustor 22 which circumscribes the turbine section 16 and an adjacent portion of shaft 18. The air 20 is mixed within the
5 combustor with fuel 24, the resulting fuel-air mixture being continuously burned and discharged from the combustor across turbine section 16 in the form of hot, expanded gas 26. This expulsion of the gas 26 simultaneously drives the turbine and compressor, and provides the engine's propulsive thrust.

10 Conventional combustors used in aircraft jet propulsion engines are of fixed geometry construction and are designed to be operated only within a predetermined altitude-mach number flight envelope such as envelope 28 bounded by the solid line 30 in the graph of Fig. 2. If an attempt is made to operate the conventional
15 combustor at higher altitudes or lower mach numbers than those within envelope 28 (i.e., within, for example, the cross-hatched area 32 bounded by line 30 and dashed line 36 in Fig. 2), the lean stability and altitude relight capability of the combustor are adversely affected. More specifically, if a conventional,
20 fixed geometry combustor were to be operated within the representative flight envelope expansion area 32, the combustion process in the combustor would be subject to abrupt, unintended extinguishment, causing an equally abrupt power loss. Compounding this rather serious problem, substantial difficulty would normally be
25 encountered in relighting the combustor until the aircraft dropped back into the normal flight envelope 28.

Not only is the upper boundary of a gas turbine propulsion engine's flight envelope limited by conventional fixed geometry combustor apparatus as just described, but certain other previously necessary combustor design compromises limit the engine's performance - even within the design flight envelope 28. One such limitation arising from the use of fixed geometry high temperature rise combustors is the occurrence of engine ground starting difficulty - especially at low ambient temperatures.

As will now be described with reference to Figs. 3-8, the combustor 22 of the present invention is of a unique, variable geometry construction which permits the engine 10 to be efficiently and reliably operated within the substantially expanded flight envelope 28, 32 without these lean instability, altitude relight, and ground start problems of fixed geometry combustors.

Referring to Fig. 3, the combustor 22 includes a hollow, annular outer housing 36 having an annular radially outer sidewall 38 and an annular, radially inner sidewall 40 spaced apart from and connected to sidewall 38 by an annular upstream end wall 42. Positioned coaxially within the housing 36 is an upstream end portion of an annular, hollow combustor liner 44 having a reverse flow configuration. Liner 44 has an annular upstream end wall 46 spaced axially inwardly from the housing end wall 42, and annular radially outer and inner sidewalls 48, 50 which extend leftwardly (as viewed in Fig. 3) from liner end wall 46 and then curve radially inwardly through a full 180°. At their downstream termination, the liner sidewalls 48, 50 define an annular discharge opening 52 through which the hot discharge gas 26 is expelled from the interior or combustion flow passage 54 of liner 44.

The interior of housing 36 defines an intake plenum 56 which circumscribes the upstream end portion of liner 44 as indicated in Fig. 3. Compressor discharge air 20 is forced into plenum 56 through an annular inlet opening 58 which circumscribes the liner 44 and is positioned at the left end of combustor 22. A portion of this pressurized air is used to cool the liner sidewalls 48, 50 during combustor operation. Although these sidewalls are, for the most part, shown in Fig. 3 as being of solid construction for the sake of clarity, they are actually of a conventional "skirted" construction. More specifically, except for an area of the combustor liner described subsequently, the sidewalls 48, 50 have, along axially adjacent portions of their lengths, overlapping, radially spaced inner and outer wall segments 48a, 48b and 50a, 50b (only one set of such inner and outer wall segments being representatively illustrated in Fig. 3). To cool the walls 48, 50 air 20 is forced inwardly through openings 49, 51 formed respectively through the wall segments 48b, 50b. The entering air impinges upon the inner wall segments 48a, 50a and enters the combustion flow passage 54, in a downstream direction, through exit slots 48c, 50c formed between the skirted wall segments.

At the upstream end of the liner 44 is an annular liner inlet plenum 60 which is positioned axially between the liner end wall 46 and an annular liner interior wall 62 which is axially spaced in a downstream direction from the liner end wall 46. The plenum 60 opens radially outwardly through the outer liner sidewall 48 through a circumferentially spaced series of inlet slots 64 (only one of which is shown in Fig. 3) formed through sidewall 48. Extending downstream from the interior wall 62 is a dome portion 54a of the combustion flow passage 54 which is radially bounded by

inner and outer annular cooling skirts 66, 68. Cooling skirts 66, 68 are spaced inwardly from the inner and outer liner sidewalls 50, 48, respectively, and define with the liner sidewalls axially extending cooling passages 70, 72 which open in a downstream direction into the combustion flow passage 54 as indicated in Fig. 3. Cooling passage 70 communicates at its upstream end with the liner inlet plenum 60 through a circumferentially spaced series of air passages 74 formed through the liner interior wall 62, while the annular cooling passage 72 communicates with the plenum 60 through a circumferentially spaced series of air flow passages 76 also extending through the interior wall 62. In a manner subsequently described, compressor discharge air 20 is selectively admitted to the liner plenum 60 and is forced axially through the annular flow passages 70, 72 and into the combustion flow passage 54 to thereby cool the inner wall surfaces of the liner dome portion 54a similarly to the cooling of the inner liner wall surfaces achieved by the cooling skirts 48a, 50a.

To inject fuel 24 into the dome area 54a, a circumferentially spaced series of fuel nozzles 78 are utilized. The nozzles 78 project axially inwardly through the liner end wall 46, the liner plenum 60, and the liner interior wall 62 into the dome area 54a (see also Fig. 4). Each of these fuel nozzles is of a piloted air blast type, being supplied by a pair of fuel lines 80, 82 extending inwardly through the housing end wall 42. At the inner end of each of the nozzles is a pressure atomizing fuel outlet (not specifically illustrated) and an air blast fuel spray outlet (also not specifically illustrated). In a conventional manner the nozzles may be staged to deliver fuel through either of the atomizing or air blast outlets.

Coannularly circumscribing each of the nozzles 78, and carried by the liner interior wall 62, are a pair of annular air swirlers 84, 86 which provide communication between the liner dome area 54a and the liner plenum 60 radially inwardly of the cooling skirts 66, 68. Primary combustion air is admitted to the flow passage 54 through a circumferentially spaced series of inlet orifices 88 positioned immediately downstream from the dome area 54a. At the left end of the liner 44 is an annular plenum 90 which opens outwardly into the housing plenum 56 through a circumferentially spaced series of slots 92 formed through the liner side wall 48, and communicates with the combustion flow passage 54 through a circumferentially spaced series of inlet passages 94 extending inwardly through the sidewall 48.

The previously described structure of the combustor 44 uniquely permits its geometry to be effectively varied by selectively blocking or unblocking the inlet slots 64, 92, in a predetermined manner which will now be described, to substantially enhance the lean stability and starting capabilities of the engine 10.

Referring now to Figs. 3, 3A, 3B and 8, to selectively block and unblock the liner plenum inlet slots 64, a first sealing member in the form of a valve ring 96 is provided. Ring 96 coaxially circumscribes and outwardly overlies an upstream end portion of the combustor liner 44 as best illustrated in Fig. 3. Ring 96 is axially movable relative to the combustor liner between a closed position illustrated in Fig. 3, and an open position illustrated in Fig. 3A. A left or forward axial portion 96a of ring 96 is

radially outwardly enlarged and has formed therethrough a circumferentially spaced series of inlet slots 98 (Fig. 8). This forward portion 96a of the ring 96 is slidably and sealingly engaged by a piston ring 100 carried by the outer liner wall 48, while
5 the right or rear portion 96b of ring 96 is slidably and sealingly engaged by a piston ring 102 which is carried by the liner end wall 46.

At the left end of the combustor liner a second sealing member 104 is provided for selectively blocking and unblocking the
10 inlet slots 92. Ring 104 coaxially circumscribes and outwardly overlies the liner sidewall 48 for slidable axial movement therealong between a closed position indicated in Fig. 3A and an open position shown in Fig. 3. With the sealing ring 104 in its closed
15 position, the inlet ports 92 are blocked to preclude entry there-through of compressor discharge air 20, an annular lip 104a on the ring 104 cooperating with an overlying annular lip 106 on the liner side wall 48 to create a labyrinth seal 108 between ring 104 and side wall 48, as shown in Fig. 3A, with ring 104 in its closed position.

20 With the sealing ring 96 in its closed position, the rear axial portion 96b thereof blocks off the inlet slots 64 (Fig. 3) to preclude entry of compressor discharge air 20 into the liner inlet plenum 60, the piston rings 100, 102 providing annular air flow seals between the combustor liner and the ring 96 adjacent the
25 opposite ends of the plenum 60.

Referring now to Figs. 3 and 8, the sealing rings 96, 104 are selectively moved in axially opposite directions (i.e. parallel to the center line or axis 110 of the combustor) between their previously described open and closed positions by a novel actuation system 112. The actuation system includes an actuation or unison ring 114 which is positioned coaxially within the housing plenum 56 immediately adjacent the outer ends of the fuel nozzles 78. The actuation ring 114 is rotatably supported within the plenum 56 by a circumferentially spaced series of bearing support brackets 116 (only one of such brackets being illustrated in Fig. 4) which are positioned between adjacent nozzles 78 and externally secured to the liner end wall 46. Each of these brackets 116 carries a carbon bearing block 118 which is slidably received in a circumferential channel 120 (see Fig. 6) formed in the radially inner surface of the unison ring 114, thereby facilitating rotation of ring 114 within the plenum 56.

Selective rotation of the unison ring 114 is achieved by the axial movement of a control rod 122 which extends into a small housing 124, through seal means 126 carried by such housing, which is externally secured to the outer housing sidewall 38 over an opening 128 extending therethrough. Control rod 122 extends lengthwise generally tangentially to the outer surface of housing sidewall 38 and perpendicularly to the combustor axis. The inner end of the control rod 122 is pivotally secured to one end of a connecting rod 130 which extends radially inwardly through the sidewall opening 128 and is secured at its inner end to the unison ring 114. As viewed in Fig. 4, inward axial movement of the control rod 122, which may be achieved by conventional control

means (not illustrated) positioned outside the combustor housing, moves the connecting rod 130 to the left within the opening 128 and causes a counter-clockwise rotation of the unison ring 114. In a similar manner, an outward axial movement of the control rod causes
5 a clockwise rotation of the unison ring.

Such selective rotation of the unison ring 114 is utilized to cause the opposite axial motion of the sealing rings 96, 104 by linking means in the form of four circumferentially spaced sets of actuating rods 132, 134 (only one such rod set being illus-
10 trated in Figs. 3 and 8) which extend axially within the housing sidewalls 48, 38 and are connected to the unison ring 114 by means of four circumferentially spaced bell crank members 136.

Referring again to Figs. 3 and 8, each of the four bell crank members 136 has a base leg portion 138 which is pivoted at
15 its outer end to the unison ring 114 (as at 140) and extends from its pivot point, in a generally axial direction toward the housing end wall 42, to a radially outwardly directed trunk portion 142 which is pivoted in a support bracket 144 as indicated in phantom in Fig. 8. Each of the four support brackets 144 is secured to
20 the liner end wall 46 between an adjacent pair of nozzles 78 as can be best seen in Fig. 4. Like the previously described bearing brackets 116, each of these support brackets 144 also carries a carbon bearing block 118 (see Fig. 3) which slidably engages the inner surface of the unison ring 114.

25 Extending transversely in opposite directions from the bell crank member's trunk portion 142 are a pair of control arms 146, 148 (Fig. 8). The outer end of each arm 146 is pivotally

connected to one end of an actuating rod 132 which is secured at its opposite end to the sealing ring 104. In a similar manner, the outer end of each arm 148 is pivotally connected to one end of an actuating rod 134, the other end of such actuating rod 134
5 being secured to the sealing ring 96.

As viewed in Fig. 8, when the control rod 122 is moved axially inwardly, the unison ring is rotated in a clockwise direction. This pivots the bell crank member trunk portion 142 in a counter-clockwise direction within the support bracket 144. This,
10 in turn, simultaneously causes leftward axial motion of each of the actuating rods 132, and rightward axial motion of each of the actuating rods 134, thereby simultaneously moving the sealing ring 104 leftwardly towards its closed position, and moving the sealing ring 96 rightwardly towards its open position. Outward axial mo-
15 tion of the control rod 122 causes opposite axial movement of each of the sealing rings 96, 104.

To laterally stabilize the much longer actuating rods 132, each of them is slidably extended through a journal portion 144a of its associated support bracket 144 (Fig. 5) and an addi-
20 tional journal support 150 (Fig. 3) carried by the outer housing sidewall 38. Such journalling also rotationally stabilizes the sealing ring 104, thereby assuring a smooth sliding motion thereof along the liner sidewall 48. A similar rotational stability is also provided to the sealing ring 96 by means of a channel 152
25 (Fig. 5) which is formed in a guide member 154 secured to the sealing ring 96, the channel 152 slidably receiving a downturned lip portion 156 of support bracket 144 (see also Fig. 4).

OPERATION OF COMBUSTOR 22

During normal operation of the combustor 22, the actuation system 112 is utilized to move the sealing ring 96 to its open position (Fig. 3B) and to simultaneously move the sealing ring 104 to its closed position (Fig. 3A). With the sealing rings in their normal operating positions, compressor discharge air 20 in the housing plenum 56 is forced inwardly through the sealing ring inlet slots 98 into the liner plenum 60. From the plenum 60 entering air 20 is forced outwardly through the dome wall cooling slots 70, 72 and is also forced into the combustor dome portion 54a through the annular air swirlers 84, 86 in a swirling flow pattern. The entering swirl air is mixed with the fuel and fuel-air mixtures discharged from the nozzles 78, further mixed with the primary combustion air entering through the primary orifices 88, and continuously burned.

The fuel richness within the combustor dome area 54a may be selectively varied both by variably staging the fuel nozzles 78 and by moving the sealing ring 96 toward its closed position, thereby blocking off a portion of the sealing ring inlet slots 98. Such movement of the sealing ring 96 toward its closed position simultaneously reduces air flow through the wall cooling slots 70, 72 and through the swirler plates 84, 86. This, in turn, reduces the dome wall cooling, thereby elevating the combustion temperature in the dome area, and reduces the total amount of swirler air entering the dome area. By virtue of this unique ability to simultaneously vary both the fuel richness and the dome wall temperature, the overall combustion stability of the combustor 22 is substantially improved compared to conventional fixed geometry

combustors, thus permitting reliable and efficient normal operation of the engine 10 within the expanded flight envelope portion 32 of Fig. 2.

Should combustion in the combustor 22 be extinguished
5 at altitude, the combustion is easily and rapidly reinitiated, even in the expanded flight envelope portion 32, by utilizing the actuation system 112 to move the sealing rings 96, 104 to their fully closed and fully opened positions, respectively, as depicted in Fig. 3. With the sealing ring 96 in its fully closed position,
10 all swirler air flow to the dome area 54a, and all cooling air flow through the skirted dome cooling slots 70, 72 is terminated. The nozzles 78 are then staged to their pilot position, and fuel 24 injected into the dome from the pressure atomizing outlets of the nozzles 78 is mixed with primary combustion air entering the
15 orifices 88. This mixture is ignited by conventional igniter means 158 to reestablish combustion.

It is important to note that with the sealing ring 96 in its fully closed position, and the nozzles staged to their pilot conditions, the fuel richness within the dome area 54 is
20 maximized. Moreover, at the same time, the dome cooling is minimized, thereby maximizing the dome combustion temperature. These cooperating features of the improved combustor 22 provide greatly improved altitude relight capabilities, thereby adding yet another measure of safety and reliability to the combustor when it
25 is operated within the expanded flight envelope zone 32.

- The altitude restart capabilities of the combustor 22 are further enhanced when the sealing ring 104 is brought to its fully opened position by the actuation system 112. During
5. altitude relight procedures with conventional fixed geometry combustors, excess compressor discharge air is intentionally bypassed around the combustor and bled off to atmosphere. However, in the present invention, such compressor discharge air is uniquely
10. utilised to assist in the altitude restart procedure. More specifically, with the sealing ring 104 in its fully opened position, this previously wasted excess compressor discharge air is forced inwardly through the inlet slots 92, the plenum 90 and the inlet
15. passages 94 into the combustion flow passage 54. The entering compressor discharge air is then forced outwardly through the combustor outlet opening 52 and across the bladed turbine section 16 to greatly assist in the "windmill" restarting of the engine 10.
20. During normal operation with the sealing ring 96 in its open position, the sealing ring 104 is in its closed position so that the air for combustion is not extracted through the passages 94.
- The previously described maximisation of the fuel
25. richness and wall temperatures within the dome area 54a not only improves the altitude relight and lean stability characteristics of the engine 10 but also substantially improves its ground start capabilities - especially in low ambient temperature
30. conditions.

In summary, the present invention provides improved combustor apparatus, and associated operating methods, which eliminate or substantially reduce the stability and relight problems commonly associated with conventional fixed geometry combustors.

5.

CLAIMS

1. A combustor for example for a gas turbine engine including a liner (44) defining a combustion passage (54) and an inlet (98) for air for the combustion passage, characterised by means (96) for controlling the
5. passage of air through the inlet (98) and for controlling the entry of air to the combustion passage (54) through two different passages simultaneously.
2. A combustor as claimed in Claim 1 in which the
10. controlling means (96) is at an ignition zone region (54a) at an upstream part of the combustion passage.
3. A combustor as claimed in Claim 2 in which there
15. is a second inlet (92) for the supply of air to the combustion passage downstream of the ignition zone and in which the entry of air to the first and second inlets (98,92) is controlled simultaneously in opposite senses.
- 20.
4. A combustor as claimed in Claim 2 or Claim 3 in which the said two different passages comprise swirler means (84,86) and liner cooler passages (70,72) at the ignition zone (54a), the two passages
25. being varied simultaneously in the same sense.
5. A combustor as claimed in any of the preceding claims including an actuator (Figure 4) for the control means (96) and including a ring (114) mounted for
30. rotation around an axis of the combustor and linking means (Figure 7) for axially moving the controlling means (96) in response to rotation of the ring (114).

6. A combustor as claimed in Claim 5 in which the linking means comprise a circumferentially spaced series of bell crank members (142) pivotally connected to said ring (114), means for connecting

5. said bell crank members to said liner for rotation relative thereto about axes generally perpendicular to said combustor axis, a first circumferentially spaced series of actuating rods (134) connected at their opposite ends to one of the controlling means

10. (96) and to one of said bell crank members, and a second circumferentially spaced series of actuating rods (132) connected at their opposite ends to a second passage control means (104) and to one of said bell crank members, and a control member (122,130)

15. movably extendable into said combustor to selectively rotate said unison ring.

7. A combustor as claimed in any of the preceding claims including a liner plenum (60) at the upstream

20. end of the combustion passage for the reception of air through the controlling means (96) and the delivery of air to the upstream end of the combustion passage (54) through the said two different passages (84,86) and (70,72).

25.

8. A combustor as claimed in any preceding claim in which the liner (44) has an annular end wall (46) within a housing and defining with the housing an air intake plenum (56).

30.

9. A combustor as claimed in Claim 8 including an array of fuel nozzles (78) in the annular end wall, and an array of primary air inlets (88) in the wall of the liner.
- 5.
10. A method of operating a combustor comprising the steps of (a) flowing pressurised air from a source (56) thereof into a liner (48) of said combustor through an inlet opening (98) formed in said liner;
10. (b) utilising a first portion (70,72) of the pressurised air entering said liner to cool an interior surface portion of said liner; (c) utilising a second portion (84,86) of the pressurised air entering said liner as combustion air within said liner; (d) mixing
15. said combustion air with fuel (24) and burning the fuel-air mixture within said liner and (e) simultaneously controlling the cooling of said interior surface portion and the richness of said fuel-air mixture by selectively varying the air inflow through said
20. inlet opening (98).
11. A method of operating a gas turbine engine having a compressor section, a turbine section and a combustor, said combustor having an outer housing
25. (38) at least partially enveloping a combustion liner (48) and defining therewith an inlet plenum (56) in said housing for receiving pressurised discharge air from said compressor section, said combustion liner having an internal combustion flow passage (54)
30. and first and second mutually spaced inlet openings (98,92) for flowing pressurised air from said housing

- plenum into said combustion flow passage, said method comprising the steps of: (a) flowing pressurised air from said housing plenum inwardly through said first inlet opening (98) while blocking said second inlet opening (92) during normal operation of said engine; (b) utilising air received through said first inlet opening means to simultaneously cool an interior surface portion of said liner and to supply combustion air to said combustion flow passage; (c) flowing
5. pressurised air from said housing plenum inwardly through said second inlet opening (92) while blocking said first inlet opening (98) during starting of said engine; and (d) utilising air received through said second inlet opening (92) to assist in driving said
 10. turbine section during starting of said engine.
 - 15.

20.

114

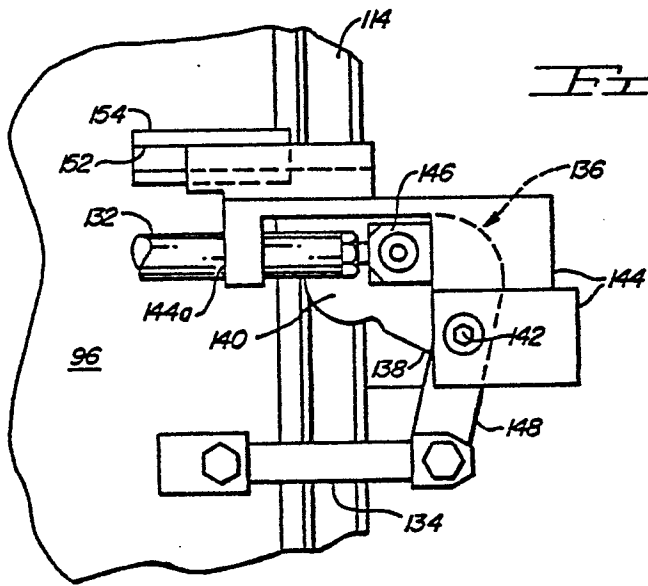
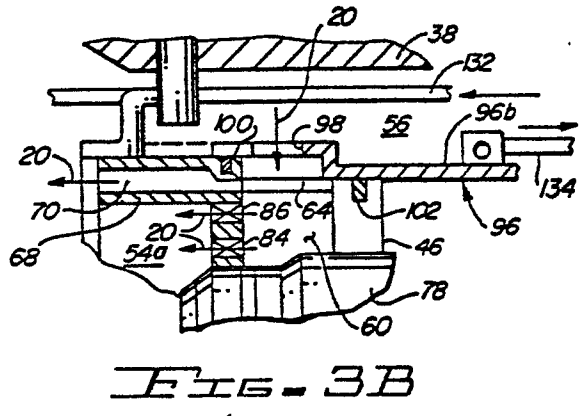
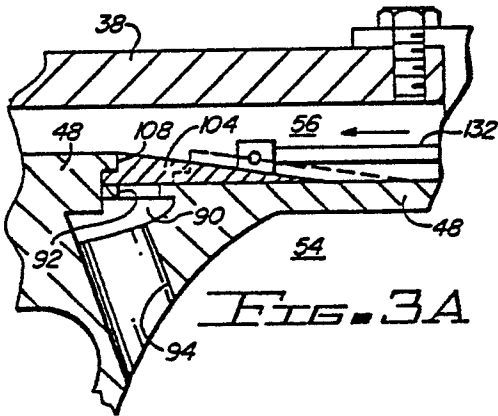
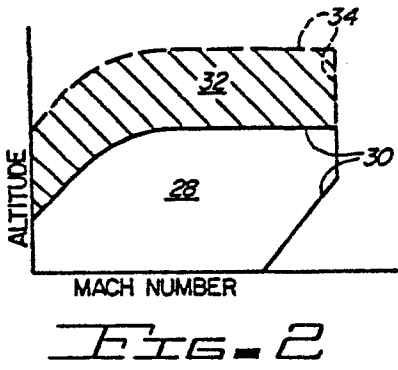
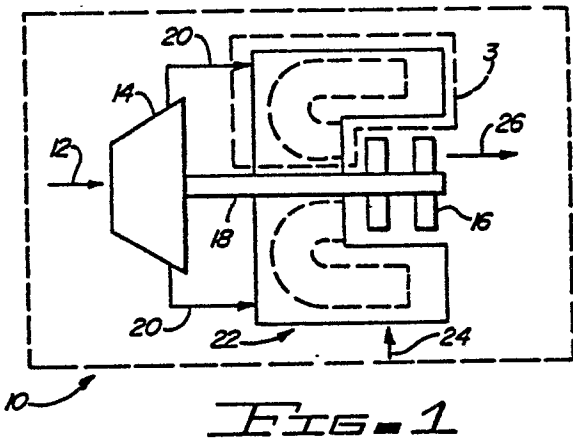

2/4

0100135

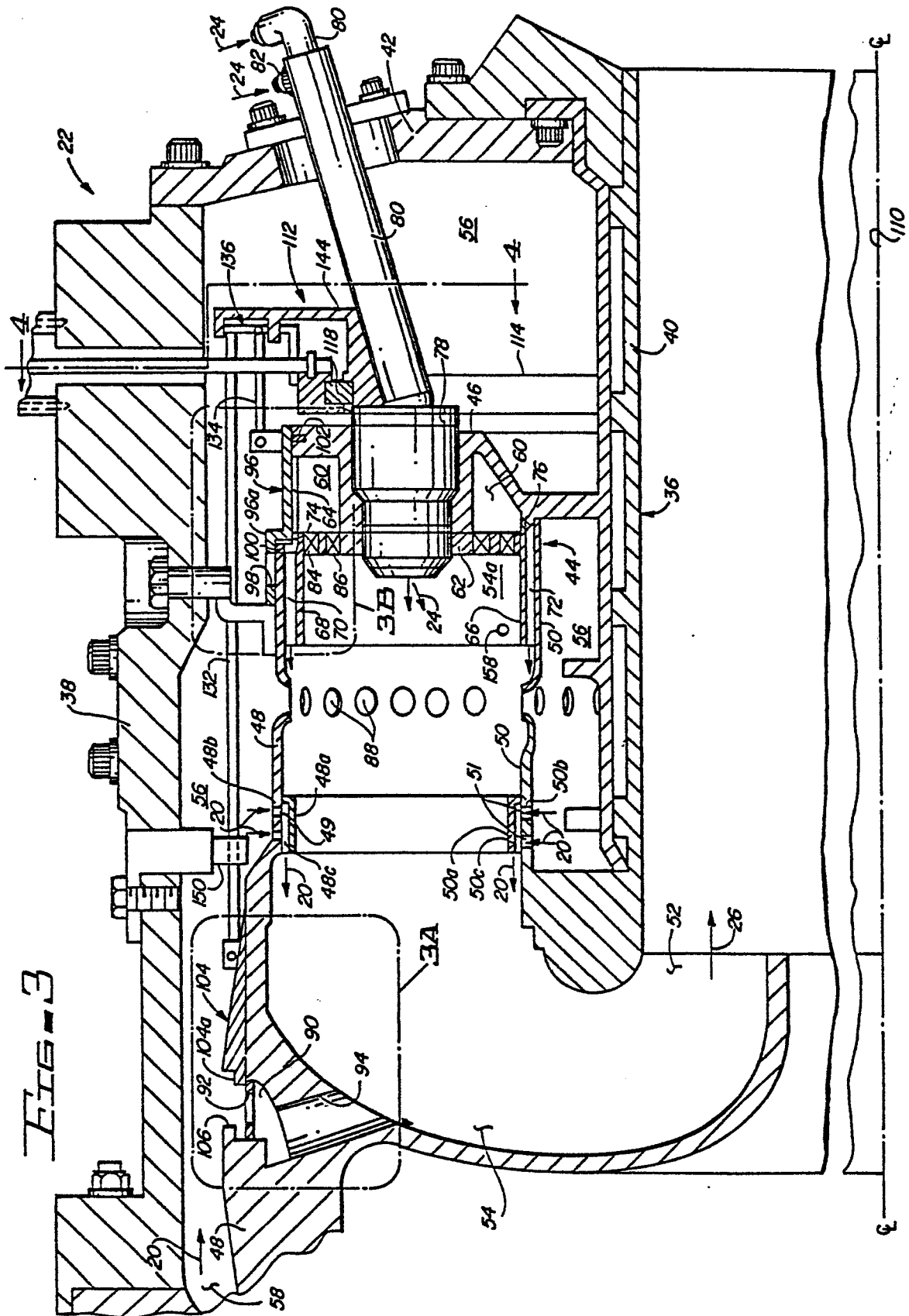

3/4

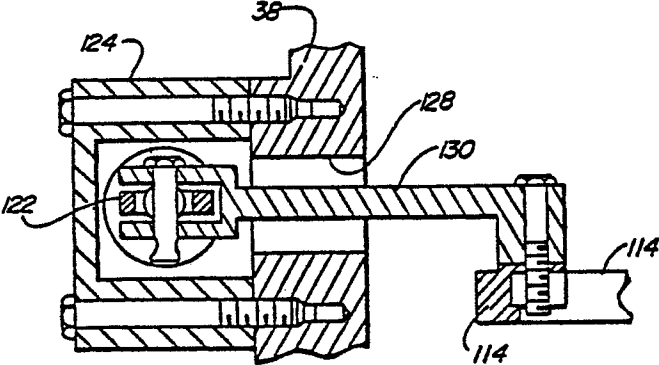
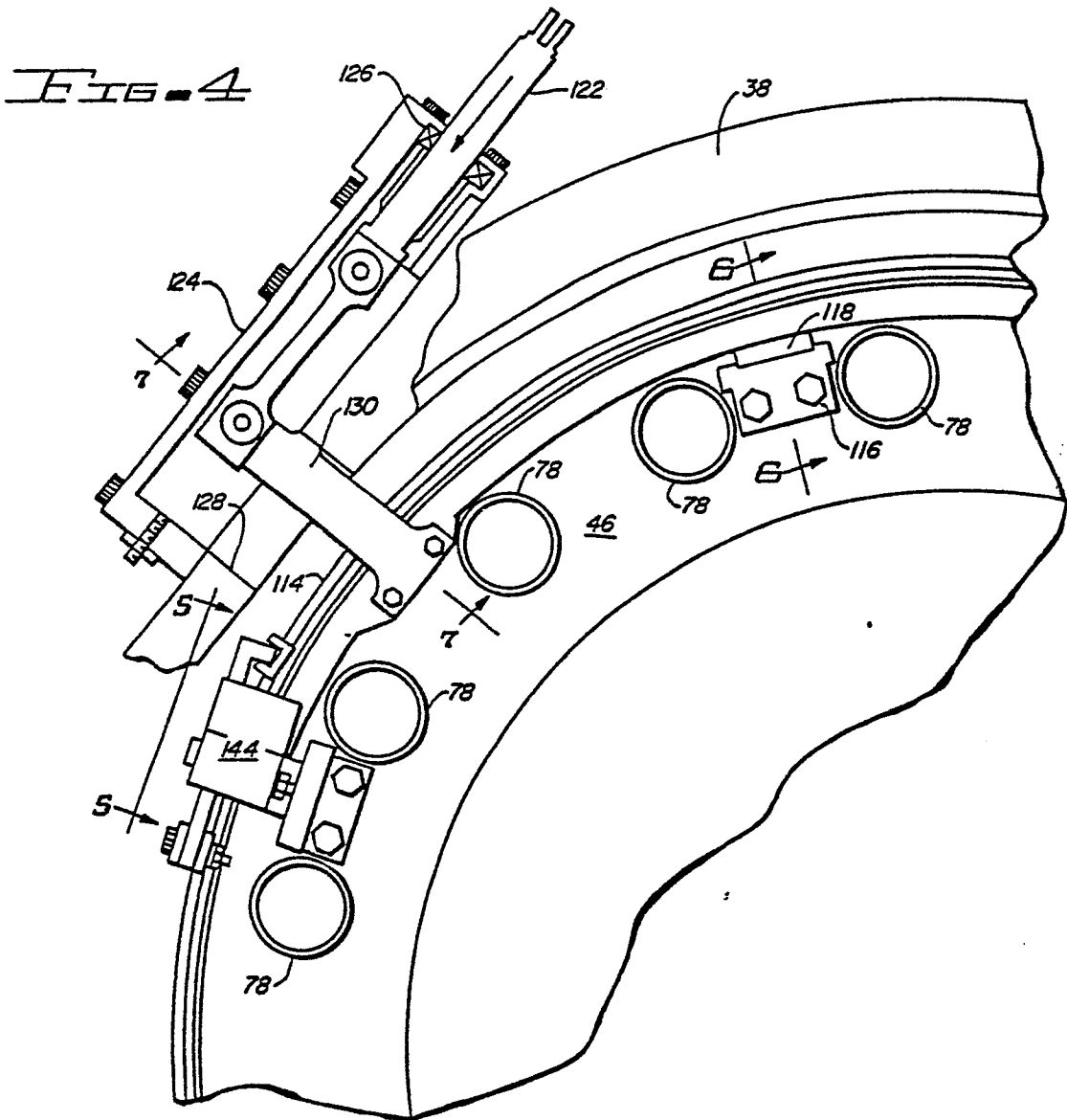

FIG. 7

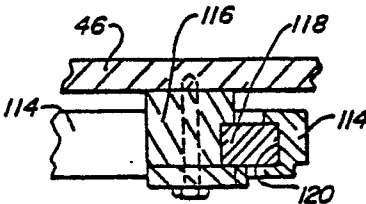

FIG. 6

4/4

0100135

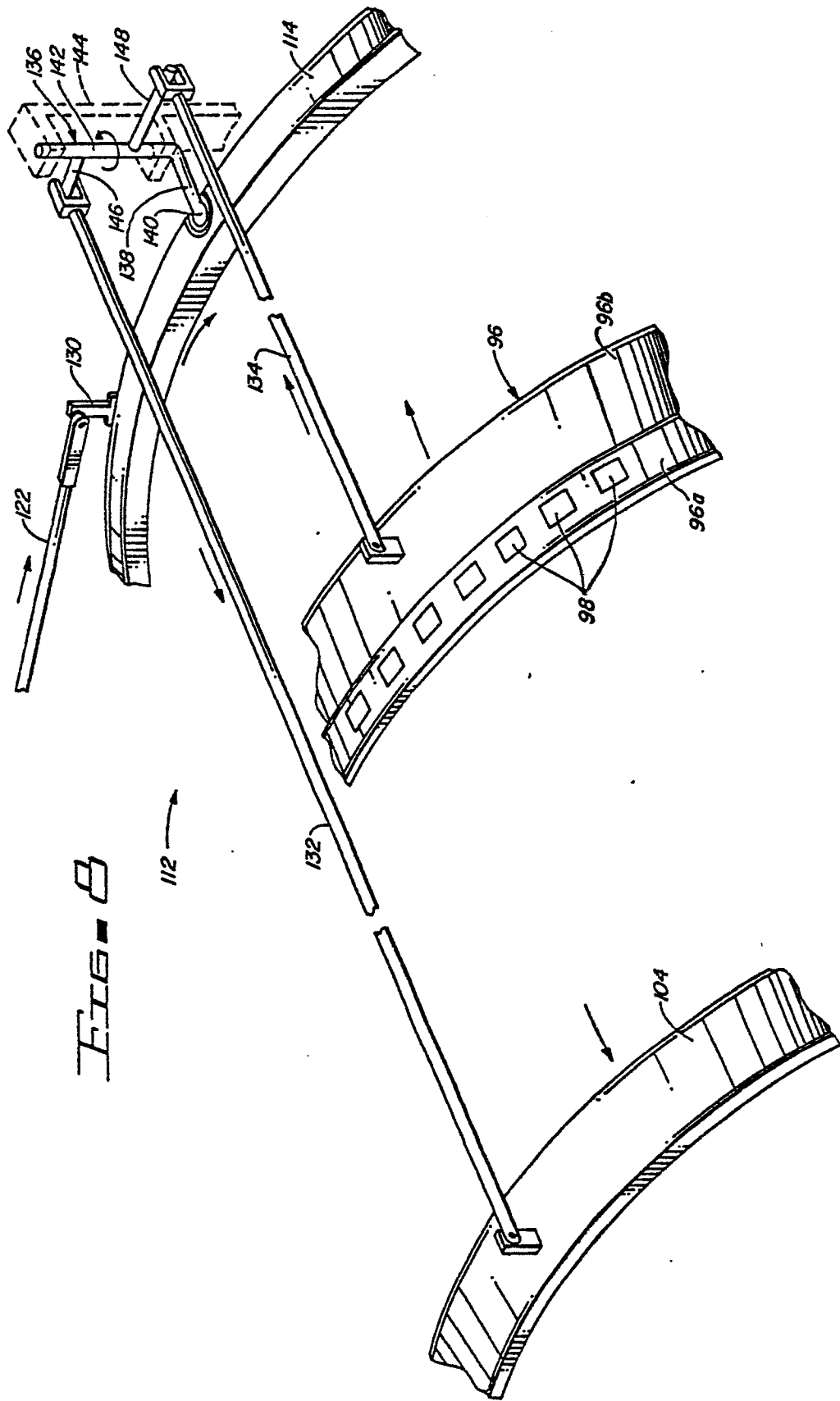

FIG. 8



DOCUMENTS CONSIDERED TO BE RELEVANT			EP 83301586.0
Category	Citation of document with indication, where appropriate, of relevant passages	Relevant to claim	CLASSIFICATION OF THE APPLICATION (Int. Cl. 3)
X	<p><u>EP - A1 - 0 026 594</u> (GENERAL MOTORS CORP.)</p> <p>* Totality ; especially page 14, lines 2-17; claims 1,2 *</p> <p>--</p>	1-3,8,10	F 23 R 3/26
X	<p><u>US - A - 3 927 520</u> (ARVIN et al.)</p> <p>* Totality, especially fig. 1-5,11; column 6, lines 59-62 *</p> <p>--</p>	1-3	
X	<p><u>US - A - 3 930 368</u> (ANDERSON et al.)</p> <p>* Totality, especially, column 3, lines 24-29 *</p> <p>--</p>	1-3	
X	<p><u>US - A - 3 919 838</u> (ARMSTRONG et al.)</p> <p>* Fig. 1; column 2, lines 23-44 *</p> <p>----</p>	1-3	<p>TECHNICAL FIELDS SEARCHED (Int. Cl. 3)</p> <p>F 23 R 3/00</p> <p>F 02 C 7/00</p>
The present search report has been drawn up for all claims			
Place of search VIENNA		Date of completion of the search 10-10-1983	Examiner PIPPAN
<p>CATEGORY OF CITED DOCUMENTS</p> <p>X : particularly relevant if taken alone Y : particularly relevant if combined with another document of the same category A : technological background O : non-written disclosure P : intermediate document</p> <p>T : theory or principle underlying the invention E : earlier patent document, but published on, or after the filing date D : document cited in the application L : document cited for other reasons</p> <p>& : member of the same patent family, corresponding document</p>			