

- [54] TOY AIRPLANE
- [75] Inventor: Arthur P. Venditti, Peabody, Mass.
- [73] Assignee: General Mills Fun Groups, Inc., Minneapolis, Minn.
- [**] Term: 14 Years
- [21] Appl. No.: 741,183
- [22] Filed: Nov. 12, 1976

- [51] Int. Cl. D21-01
- [52] U.S. Cl. D34/15 HH
- [58] Field of Search D34/15 HH, 15 HR;
D12/71, 73, 74, 77, 78, 80; 46/74 R, 76 R, 77,
78, 79, 81

[56] **References Cited**
U.S. PATENT DOCUMENTS

- 1,581,646 4/1926 Larsen 46/76 R
- 1,912,925 6/1933 Wallace 46/76 R

2,595,074 4/1952 Guillow 46/79

OTHER PUBLICATIONS

Toys, 1-1973, p. 43, Balsa Glider.
Primary Examiner—Winifred E. Herrmann
Assistant Examiner—C. A. Rademaker
Attorney, Agent, or Firm—Gene O. Enockson

[57] **CLAIM**

The ornamental design for a toy airplane, substantially as shown and described.

DESCRIPTION

FIG. 1 is a front perspective view of a toy airplane illustrating my new design;
 FIG. 2 is a top plan view thereof;
 FIG. 3 is a side elevational view thereof the side opposite being substantially a mirror image;
 FIG. 4 is a bottom plan view thereof;
 FIG. 5 is a front elevational view thereof; and
 FIG. 6 is a rear elevational view thereof.

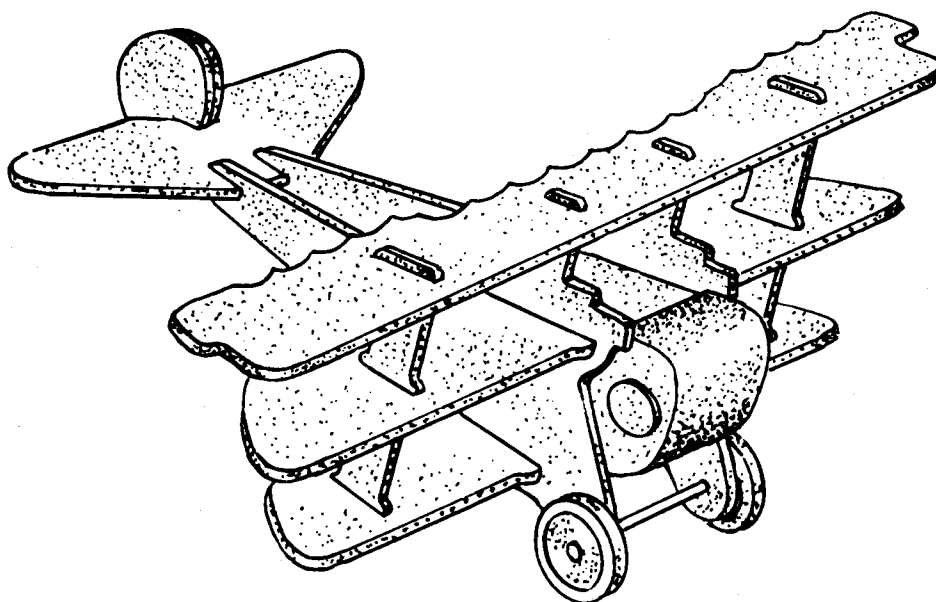

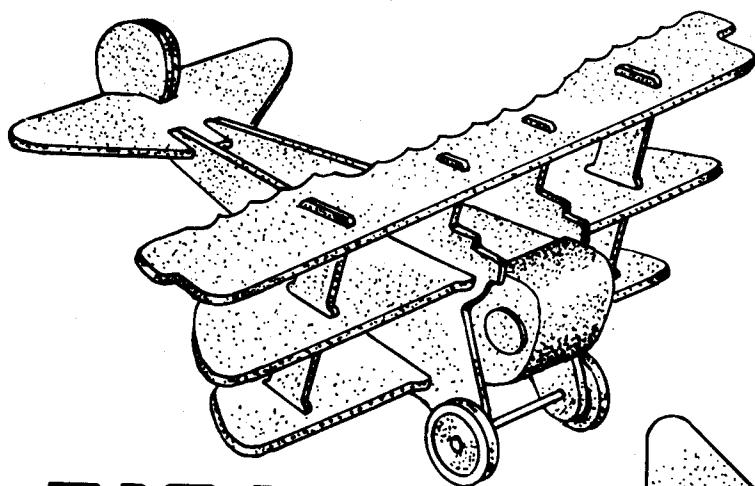

FIG. 1

FIG. 2

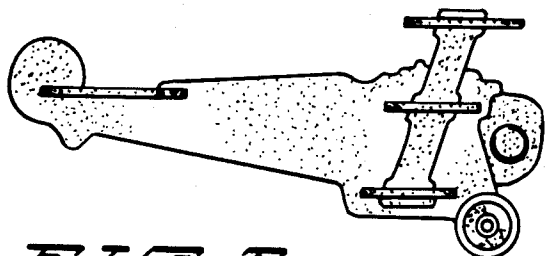
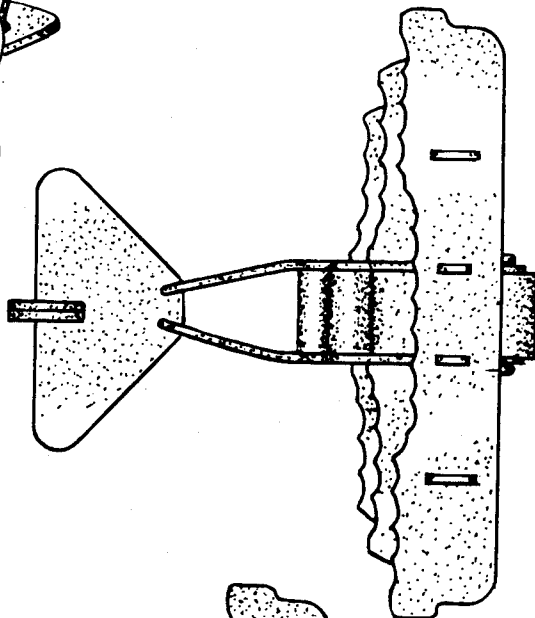

FIG. 3

FIG. 4

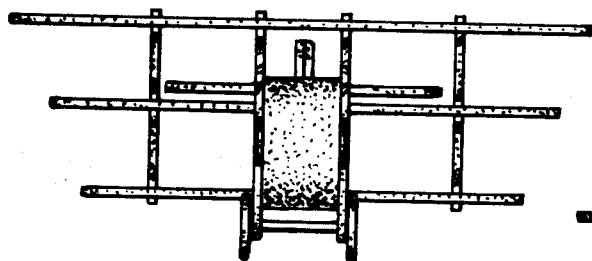
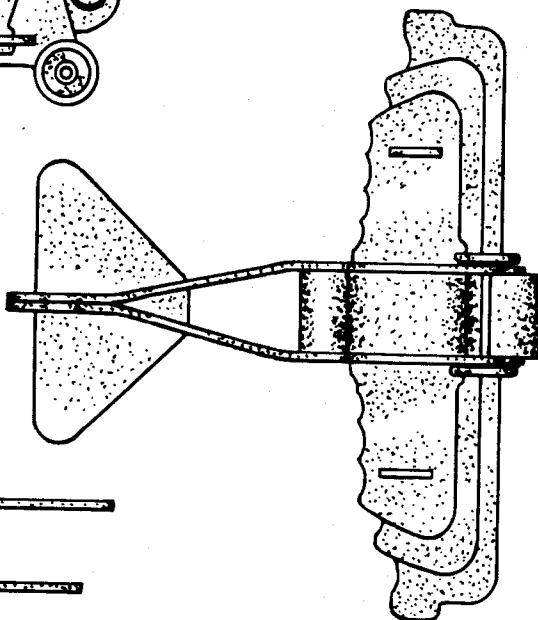

FIG. 5

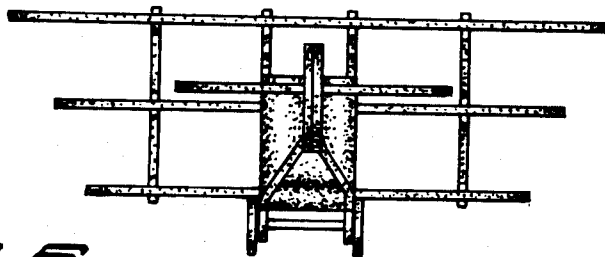

FIG. 6