

No. 773,680.

PATENTED NOV. 1, 1904.

J. B. SALO.
INCANDESCENT BURNER.
APPLICATION FILED NOV. 13, 1903.

NO MODEL

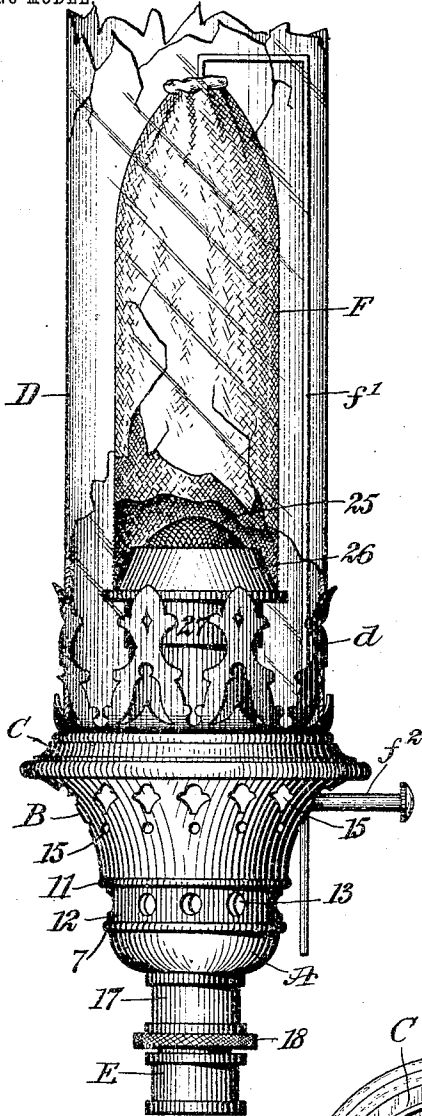

FIG. 1.

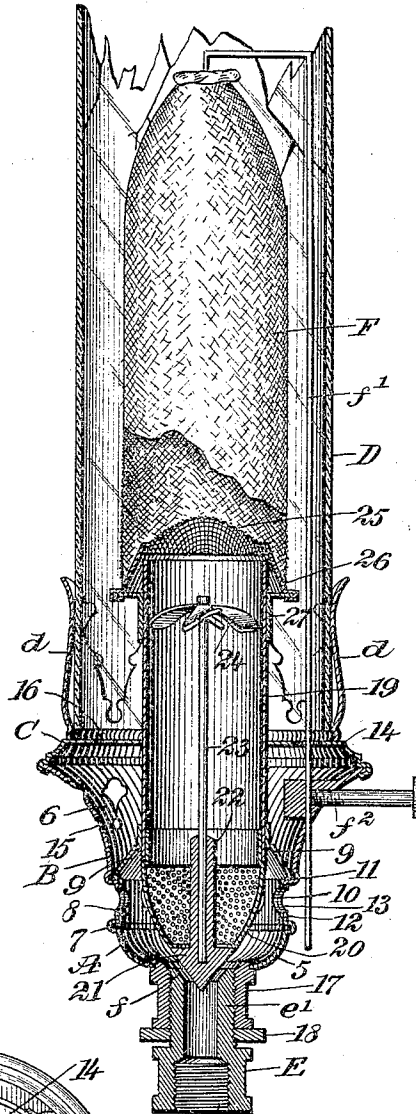

FIG. 2.

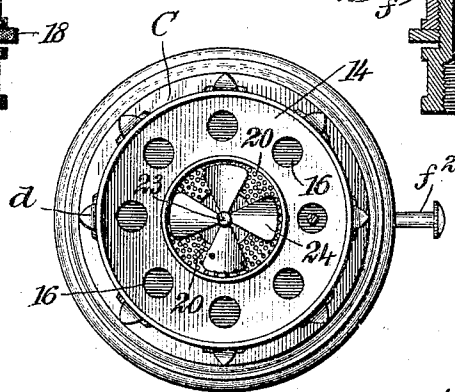

FIG. 3.

WITNESSES:

W. B. Smith
A. J. Bernhard

INVENTOR

John B. Salo

BY

Mumford

ATTORNEYS

UNITED STATES PATENT OFFICE.

JOHN B. SALO, OF NEW YORK, N. Y., ASSIGNOR OF ONE-HALF TO ANDREW
H. HOAG, OF NEW YORK, N. Y.

INCANDESCENT BURNER.

SPECIFICATION forming part of Letters Patent No. 773,680, dated November 1, 1904.

Application filed November 13, 1903. Serial No. 181,031. (No model.)

To all whom it may concern:

Be it known that I, JOHN B. SALO, a citizen of the United States, and a resident of the city of New York, borough of Manhattan, in the county and State of New York, have invented a new and Improved Incandescent Burner, of which the following is a full, clear, and exact description.

My invention relates to improvements in incandescent burners of that class wherein provision is made for supplying a central-draft current of combustible vapor or gas to an incandescent mantle.

In this invention I seek to provide a simple and compact construction wherein a current of carbureted air is caused to be split or divided into minute thin streams and to be intimately combined with atmospheric air at the burner, thus producing an aerated combustible vapor which will burn to the best advantage and heat the mantle to a state of incandescence. I also aim to make the burner adjustable in two respects—first, to regulate the volume of gas or combustible vapor, and, second, to control the volume of air which is admitted to the burner for admixture with the gas or combustible vapor.

Further objects and advantages of the invention will appear in the course of the subjoined description, and the actual scope thereof will be defined by the annexed claims.

Reference is to be had to the accompanying drawings, forming a part of this specification, in which similar characters of reference indicate corresponding parts in all the figures.

Figure 1 is a side elevation, partly broken away, of an incandescent burner constructed in accordance with my invention. Fig. 2 is a vertical sectional elevation thereof; and Fig. 3 is a plan view of the burner, omitting the chimney, the mantle, and the foraminous gas-check, the latter surmounting the central-draft mixing-tube.

It is well known to those skilled in the art that a combustible vapor formed by the mechanical admixture of hydrocarbon with air is quite heavy and that it is difficult to secure a proper and intimate admixture of atmospheric air with a carbureted combustible va-

por. In the present invention I seek to provide a burner especially adapted for consuming a carbureted combustible vapor and to construct this burner with means whereby the desired admixture of air with the vapor may be advantageously carried into effect.

In the drawings the casing of the burner is shown as consisting of three parts A B C, which are constructed and united in a way to produce a lower vapor-chamber 5 and an upper air-chamber 6. The lower member A of the casing is shown as having a bead or flange 7 at a point intermediate of its height, and above this bead said member A has a cylindrical portion 8, while above this cylindrical portion the member is reduced in diameter, as indicated by the conical portion 9, the whole member A being formed of a single piece of spun metal. The cylindrical upstanding portion 8 of the member A is provided with an annular series of transverse air-openings 10, the latter being located in a plane between the annular bead 7 and the contracted upper portion 9 of the member.

The member B is provided with an annular bead 11, and below this bead the member B is formed with an annular portion 12, having a plurality of air-holes 13, while above the bead 11 said member B flares upwardly and outwardly, as shown by Figs. 1 and 2. The lower perforated portion 12 of the member B slightly exceeds the external diameter of the perforated annular portion 8 of the lower member A, whereby the upper member B is revolvably fitted upon the lower member A in a way for the lower edge of said member B to rest upon the annular bead 7 of the member A. The perforated lower portion 12 of the member B snugly embraces the annular perforated portion 8 of the member A in a way to bring the holes 13 of said member B into registration with the holes 10 of the member A, thereby producing a plurality of air-ports, which have communication with the chamber 5 and are adapted to be varied in size by the adjustment of said member B upon the lower member A.

The member C of the casing is constructed to form a diaphragm 14, and said member is

joined to the upper flared portion of the member B by flanging the parts B C together in an ordinary way. The member B is provided with a plurality of air-inlet openings 5 15, which are shown by Figs. 1 and 2 as being disposed in two annular series, and in a like manner the diaphragm 14 of the member C has a plurality of transverse vertical openings 16, the same providing for the admission of air to the chimney D, which is adapted to rest upon the member C and to be confined in place by an ordinary gallery *d*.

E designates a nipple which is provided at its lower portion with a female threaded socket *e*, adapted to be screwed on a threaded end of the gas-pipe, which may constitute a part of a lamp or a stationary gas-fixture. This nipple E is provided at its upper portion with a reduced extension *e'*, the same being externally threaded and beveled at its upper portion, so as to produce an internal valve-seat *f*.

To the bottom portion of the member A of the casing is firmly secured in any suitable way a sleeve 17, the same being rigid or fast with said member A, so as to be adjustable therewith. The sleeve 17 is internally threaded in order to screw it upon the threaded portion *e'* of the nipple E, whereby the burner as an entirety is mounted for adjustment in a vertical direction upon the nipple. The sleeve 17 of the burner is adapted to be held firmly in either of the series of adjusted positions by a check-nut 18, which is screwed on the nipple E, and is adapted for engagement with the lower edge of the burner-sleeve 17.

19 designates a vertical tube which is arranged to pass through the diaphragm 14 and to extend through the air-chamber 6, said tube fitting snugly in the diaphragm 14 of the member C and secured firmly to the upper contracted portion 9 of the member A, as clearly shown by Fig. 2. This tube 19 occupies a stationary position with relation to the members of the casing, and to the lower extremity of the tube is fastened a foraminous mixing member 20, which is disposed within the gas-chamber 5 of the member A and is arranged therein so as to allow the gas or combustible vapor to pass from the nipple E through the chamber 5 in an upward direction. This mixing member is represented as an inverted cone or cap, and its upper larger end is secured either to the lower extremity of the mixing-tube 19 or to the upper contracted portion 9 of the member A, it only being necessary to provide for the rigid support of said mixing member 20 within the gas-chamber of the lower member A in a position which will insure the passage of gas or vapor through said member 20 before it enters the mixing-tube 19. The lower extremity of the mixing member 20 is closed, and to it is applied the base of an inverted conical valve 21, said valve being secured in a stationary position with respect to

the mixing member and occupying facing relation to the valve-seat *f* of the nipple E. As shown by Fig. 2, the conical valve has its apex extended into the nipple E, so as to lie in the path of the current of gas or combustible vapor flowing through the nipple, thus making the valve act as a means for diffusing the gaseous current uniformly into all portions of the gas-chamber 5 within the member A. It is evident that the valve 21 is adjustable with the burner when the latter is bodily raised or lowered by a rotary adjustment of the sleeve 17 on the stationary nipple E, and the passage for the gaseous current formed by and between the valve-seat *f* and the conical surface of the valve 21 may be regulated by raising or lowering the valve with the burner, thus providing a simple and efficient means for controlling the volume of the gaseous current passing from the nipple into the chamber 5.

The employment of the mixing member 20 between the points where the air is admitted to the burner and the mixing-tube 19 is an important feature of my invention, because this mixing member serves to divide or split the current of air and gas into minute streams, whereby the combustible vapor is caused to intimately combine with the air which flows through the ports formed by the coincident openings 10 13 in the lapping portions of the members A B, and a second admixture of air with the combustible vapor is thus secured.

The valve 21 is shown as having an upwardly-extending tube 22, which passes through the mixing member 20 into the mixing-tube 19, and in this tube 22 is secured the stem 23, which supports an agitator or baffle 24. This baffle may be mounted on the stem in a fixed position or it may be arranged to rotate thereon. The baffle is located within the mixing-tube 19, near the upper end thereof, and it operates to secure increased mixture of the atmospheric air with the combustible vapor.

The mixing-tube 19 is surmounted by a gas-check 25, which may be made of wire, gauze, or perforated metal, and it serves to prevent the back flash of flame into the burner when the gas or combustible vapor is admitted.

A mantle F, of any suitable or preferred character, is suspended within the chamber D, so as to envelop the upper portion of the mixing-tube 19 and the gas-check 25, and this mantle is suspended from a mantle-rod *f'*, which is secured in one member of the burner—as, for example, by the set-screw *f''*.

It is desirable to prevent the passage of air between the tube 19 and the lower portion of the suspended mantle F, and to this end I employ an air-check or baffle 26, the latter consisting of a conical member which extends upwardly to the gas-check 25 and is supported on the mixing-tube 19 by a flanged collar 27, said collar being fastened exter-

nally to the mixing-tube 19 and having its flange united to the conical portion of the air-check 26, as clearly shown by Fig. 2. The employment of this check 26 is further-
 5 more advantageous when hydrocarbon vapor is supplied to the burner in that it prevents the heavy vapor flowing from the mixing-tube from dropping through the space between the upper end of the tube 19 and the
 10 lower end of the mantle.

When the burner is not in service, the sleeve 17 is lowered by turning it on the nipple E in order to bodily lower the burner and bring the valve 21 into engagement with the seat
 15 f, thus cutting off the flow of gas or combustible vapor; but, if desired, the burner may be adjusted to a predetermined position wherein the valve 21 is normally open and the burner is held in such adjusted position
 20 by the check-nut 18, the flow of gas or combustible vapor to the nipple and the burner being controlled by an independent cock. When gas or combustible vapor is admitted to the nipple E, it flows past the valve 21 into
 25 the chamber 5, from whence the gas or vapor passes through the mixing member 20. The minute perforations of this member 20 split or divide the gas or vapor into thin streams, and the current of gas or vapor flowing into
 30 the member 20 and up through the mixing-tube 19 induces an inward flow of air through the ports formed by the coincident openings 10 13 in the lapping portions of the members A B, whereby the air is mixed with the gas
 35 or vapor as it passes through the member 20, and as it traverses the vertical mixing-tube 19 the intimate admixture of air and gas being further assured by the operation of the agitator or baffle 24. The air necessary to
 40 support combustion is supplied to the chimney and exteriorly to the mantle by the ports 15 in the member B, the air passing from the chamber 6 of said member through the perforations in the diaphragm 14 and thence into
 45 the chimney; but the air cannot flow into the lower end of the mantle F because of the presence of the air-check 26.

In the service of incandescent burners using a combustible vapor produced by charging
 50 an air-current with a hydrocarbon it is not possible to light the burner at the top, owing to the fact that the vapor is quite heavy; but an important advantage, from a practical
 55 standpoint, of my construction is the ability of the user to light the burner when it is supplied with a hydrocarbon vapor by placing a lighted match or taper over the upper end of the chimney after the current of air or combustible vapor is admitted to the lower part
 60 of the burner.

The apparatus is extremely simple in construction, because it consists of comparatively few parts, and it is efficient and reliable in operation.

Having thus described my invention, I claim 65 as new and desire to secure by Letters Patent--

1. An incandescent burner having a lower member adapted to be connected to a gas pipe or fixture, said member being provided with a valve-seat, a second member, a valve carried
 70 by the second member and adjustable with relation to the lower member, whereby the size of the exit therefrom may be regulated by the valve, a perforated member above the valve concentric with the lower member where-
 75 by a chamber is provided between the lower member and said perforated member and an air-inlet to said chamber.

2. A gas-burner comprising a chamber having air and gas inlets, a mixing-tube extending upwardly from said chamber, a movable
 80 mixing member in said chamber and a gas-valve movable therewith.

3. A gas-burner having a stationary part, a chambered casing, a valve movable with
 85 said casing with relation to the stationary part, a mixing-tube connected with the casing, and a mixing device adjacent to the inlet to said mixing-tube.

4. An incandescent burner having a station-
 90 ary part, a casing mounted on said part for adjustment vertically with respect thereto by a rotary motion, said casing having a gas-chamber and means for admitting air thereto, a mixing-chamber within the casing, and
 95 a mixing member interposed between the gas-chamber of the casing and the mixing-chamber.

5. An incandescent gas-burner having a casing provided with a gas-chamber and means for
 100 admitting air thereto, a mixing-tube extending upwardly from said casing, and a perforated substantially cylindrical mixing member within the chamber and concentric therewith communicating with the mixing-tube.
 105

6. An incandescent burner having a casing provided with a gas-chamber and with air-ports above the gas-inlet to said chamber, a
 110 mixing-tube extending upwardly from said chamber, and a perforated mixing member continuous with the tube and a gas-valve at the base of said perforated mixing member.

7. An incandescent burner having a casing consisting of members provided with air-openings and adjustable one upon the other by a
 115 rotary motion, one member of the casing having a gas-chamber, a mixing-tube extending upwardly from the casing, and a mixing member continuous with said tube and extending into the gas-chamber of one member.
 120

8. In an incandescent burner, a casing consisting of a lower member having air-openings, and an upper member revolubly fitted
 125 on the lower member and also provided with air-openings adapted to register with the openings of the lower member, in combination with a mixing-tube, a mixing member communicating with said tube and with the lower mem-

ber of the casing, and a gas-valve carried by said lower member.

9. In an incandescent burner, a casing consisting of two members fitted revolubly together, both members of said casing having 5 air-openings in their lapping parts, one member of the casing having a gas-chamber, and the other member of the casing having an air-chamber and openings for the admission of 10 air thereto, in combination with a mixing-tube extending through the air-chamber of one member, and a mixing member communicating with the mixing-tube and with the gas-chamber of the other casing member.

10. An incandescent burner having a nipple, a casing consisting of two members one of which is screwed on the nipple and the other member being shiftable upon said member so screwed to the nipple, a mixing member

mounted within the lower casing member, and 20 a valve below the mixing member and adapted to be seated upon the nipple.

11. In an incandescent burner, the combination with a mixing-tube, and means for suspending a mantle over the same, of an air and 25 gas check located externally on the mixing-tube and occupying a position below the open end of a mantle adapted to be suspended over said tube, and a perforated mixing member at the base of said mixing-tube. 30

In testimony whereof I have signed my name to this specification in the presence of two subscribing witnesses.

JOHN B. SALO.

Witnesses:

JNO. M. RITTER,
H. T. BERNHARD.