

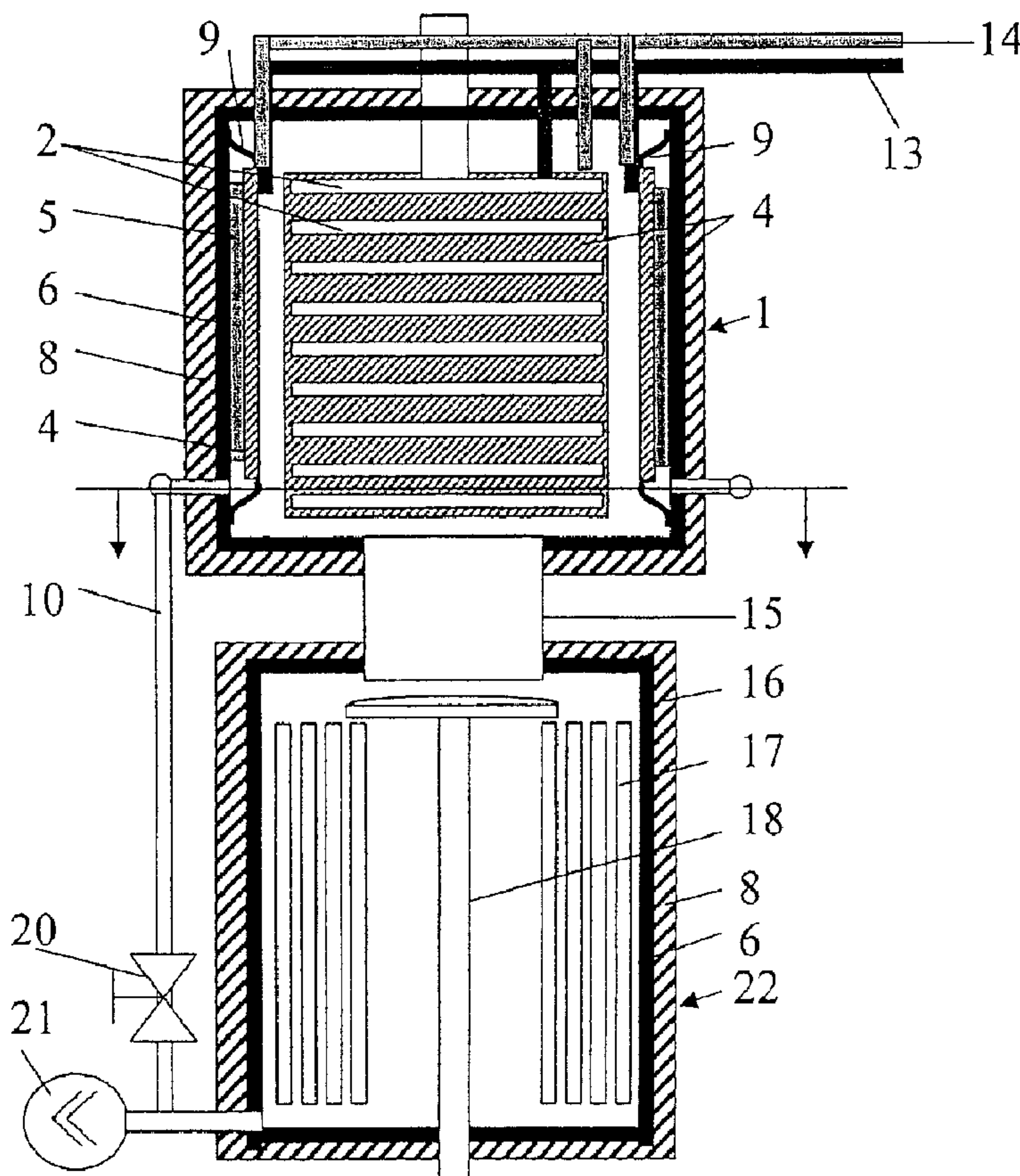

(86) Date de dépôt PCT/PCT Filing Date: 2003/04/15
 (87) Date publication PCT/PCT Publication Date: 2003/11/06
 (45) Date de délivrance/Issue Date: 2010/10/19
 (85) Entrée phase nationale/National Entry: 2004/10/20
 (86) N° demande PCT/PCT Application No.: EP 2003/003893
 (87) N° publication PCT/PCT Publication No.: 2003/091645
 (30) Priorité/Priority: 2002/04/23 (DE102 18 007.5)

(51) Cl.Int./Int.Cl. *F26B 5/06* (2006.01)
 (72) Inventeurs/Inventors:
 SENNHENN, BERND, DE;
 GEHRMANN, DIETRICH, DE;
 FIRUS, ARIANE, DE
 (73) Propriétaire/Owner:
 HOF-SONDERANLAGENBAU GMBH, DE
 (74) Agent: FETHERSTONHAUGH & CO.

(54) Titre : DISPOSITIF DE LYOPHILISATION
 (54) Title: FREEZE-DRYING DEVICE



(57) Abrégé/Abstract:

The invention relates to drying equipment for removing solvent from humid material and to a method for operating the drying equipment. The equipment comprises at least one drying chamber (23) comprising at least one support plate (2) for receiving

(57) **Abrégé(suite)/Abstract(continued):**

containers (3) filled with humid material or planar layers of humid material. The drying chamber (23) is connected to the capacitor (22) by a vapour channel (15) in which the sublimated solvent can be separated; the support plates (2) are connected to a temperature regulated heating/cooling circuit; the chamber (23) comprises heating/cooling plates (4) or (4') which are connected to a second heat transfer medium circuit. The invention is characterised in that the heating/cooling plates (4) or (4') are configured in such a manner that they can be substantially thermally decoupled from the chamber wall (6).

ABSTRACT

The invention relates to drying equipment for removing solvent from humid material and to a method for operating the drying equipment. The equipment comprises at least one drying chamber (23) comprising at least one support plate (2) for receiving containers (3) filled with humid material or planar layers of humid material. The drying chamber (23) is connected to the capacitor (22) by a vapour channel (15) in which the sublimated solvent can be separated; the support plates (2) are connected to a temperature regulated heating/cooling circuit; the chamber (23) comprises heating/cooling plates (4) or (4') which are connected to a second heat transfer medium circuit. The invention is characterised in that the heating/cooling plates (4) or (4') are configured in such a manner that they can be substantially thermally decoupled from the chamber wall (6).

Freeze-drying device

The invention relates to a freeze-drying chamber with coolable/heatable stand plates
5 for a multiplicity of product-filled vessels or with coolable/heatable stand plates
which can be occupied by layers of product, with special facilities which eliminate
the harmful influences of temperature, which are dependent on the progress of
drying, on the chamber-wall surfaces. Specific designs make it possible to avoid high
energy losses by means of a special chamber-wall structure combined, at the same
10 time, with a reduction in the mass of the temperature-controlled components.

During the drying in known freeze-drying chambers with a multiplicity of stand
plates for product-filled containers or planar product layers, the containers or product
layers in the edge region of the stand plates exchange energy more intensively than
15 the containers/product layers positioned in the centre of the plates, on account of
radiant heat exchange and natural convection in the gap between the wall and the
stack of stand plates. This inhomogeneity of the energy distribution leads to different
freezing and drying kinetics when containers or product layers at the edges are
compared with containers or product layers arranged in the centre.

20

The avoidance of the inhomogeneity is achieved by eliminating the driving potential
responsible for the lack of uniformity. The driving potential for the drying is
temperature differences between product-filled containers or product layers and their
environment which supplies the potential required for the freeze-drying to progress.
25 In the edge region of the stand plates, this potential is greater than in the central
region of the stand plate, since there is direct heat exchange between containers at the
edge and the chamber wall as a result of radiation and convection. During the
freezing process according to the prior art (at standard or slightly reduced pressure),
the natural convection of the gas in the clear gap between the wall and the
30 temperature-controlled stand plates has a particularly intensive action as a heat-
transfer medium for the containers which are exposed to the convective flow. These
additional heat fluxes decrease towards the centre of the plate and thereby cause the
lack of homogeneity in the freezing and drying of the containers or product layers
distributed over the plate.

35

According to the prior art, freeze-dryers are either produced completely without temperature-control equipment for the chamber walls or with heating/cooling jackets which are applied direct to the supporting structure. On account of the body contact with the heavy bearing structure of the chamber, these heating/cooling jackets have the purpose of cooling the chamber from the sterilizing temperature to the temperature which is suitable for loading. Then, the cooling liquid is generally emptied from these heating/cooling surfaces, in order to reduce the mass. The cooling of the chamber wall to a temperature which eliminates the driving potential responsible for the problem is not possible with these designs.

10

US-A 5,398,426 describes a freeze-dryer whose chamber walls can be cooled in order to eliminate the disruptive temperature differences by establishing identical temperatures at the chamber walls and the stand plates. This design has two drawbacks:

15

1. The additional cooling surfaces are integrated in the mechanical bearing structure of the dryer, which has to be sufficiently reinforced for it to be able to withstand evacuation. This has the drawback that large masses have to be heated/cooled when the dryer is operating. Therefore, the thermal reaction of the dryer is inevitably slow.

20

2. The control described in US-A 5,398,426, namely establishing uniform wall and stand surface temperatures, does not lead, in particular during the first drying section, the sublimation drying, to the desired elimination of the driving potential which is responsible for the problem and therefore also does not lead to the elimination of inhomogeneities, in particular during the sublimation drying.

25

The invention is therefore based on the following objects:

- 30 • eliminating the lack of uniformity between the edge region and centre region of the stand plates, which during the freezing and drying of product-filled vessels leads to uneven temperature and drying profiles of the vessels;
- a reduction in the mass of the dryer which has to be heated or cooled.

35 The lack of uniformity is eliminated by using regulated heating/cooling plates which

are set in such a way that there is no driving temperature gradient between wall and vessels. The resulting homogeneity of the freezing and drying process in all the vessels allows the uniformity of the product quality to be improved and the drying capacity to be increased considerably.

5

The driving potential which is responsible for the problem is eliminated by means of additional temperature-regulated heating/cooling surfaces which are introduced into the drying chamber. The arrangement of these heating/cooling surfaces may differ. Residual natural convection – as is produced for example between containers or
10 product layers and stand surfaces – is minimized as early as during the freezing section of the freeze-drying by an additional reduction in the pressure.

The invention relates to a drying unit for removing solvent from moist material, comprising at least one drying chamber having at least one stand plate for holding
15 vessels, which are filled with moist material, or flat layers of moist material, the drying chamber being connected to a condenser via a vapour passage, in which the sublimed solvent can be separated out, the stand plates being connected to a temperature-regulated heating/cooling circuit, the chamber having heating/cooling plates which are connected to a second heat-transfer circuit, characterized in that the
20 heating/cooling plates are designed to be substantially thermally decoupled from the chamber wall.

The lack of uniformity is eliminated by using regulated heating/cooling plates which are set in such a way that there is no driving temperature gradient between wall and
25 vessels. The resulting homogeneity of the freezing and drying process in all the vessels allows the uniformity of the product quality to be improved and the drying capacity to be increased considerably.

To allow temperature control, the stand plates can be provided with a pipeline
30 system. A stream of a temperature-regulated heat transfer medium supplied from a heating/cooling system flows through the pipeline system.

A preferred drying unit is characterized in that the heating/cooling plates or are arranged at a distance from the chamber wall.

35

Particularly preferably, the outer chamber wall is of pressure-resistant design, so that the surface forces which are active when the chamber is evacuated are absorbed without deformation.

5 A drying unit in which the outer chamber wall has a thermal insulation, so that the energy loss from the system is minimized, is also preferred.

Furthermore, a drying unit in which the heating/cooling plates are connected in a vacuum-tight manner to the chamber wall, so that the effective result is a two-
10 chamber system, is also preferred.

The heating/cooling surfaces are in particular mechanically connected, by means of spacers, to the inner side of the chamber wall, with which they form a planar gap which can be evacuated. In this arrangement, vacuum connections are provided in
15 the chamber wall.

A drying unit characterized in that the gap can be set to the pressure level of the drying chamber by means of a vacuum system, for the purposes of pressure compensation, is also preferred.

20

The spacers are preferably made from a material of poor thermal conductivity, in particular from stainless steel.

A preferred embodiment of the drying unit is characterized in that elastic metal
25 connecting sheets between lateral heating/cooling plates and the chamber wall are designed to be sufficiently flexible to compensate for the temperature-related changes in length of the heating/cooling surfaces without damage to the material.

In a further preferred embodiment of the drying unit, heating/cooling plates are
30 suspended in the drying chamber parallel to the edges of the stand plates and at a distance from the stand plates, so that the suspended heating/cooling plates form a virtually continuous radiation cage around the stack of stand plates.

In a preferred further embodiment of the drying unit, the drying chamber can be
35 evacuated as early as during the freezing operation, in order to reduce the influences

of convection.

In a particular structural form, the chamber wall has an outer thermal insulation.

- 5 In a preferred drying unit, the devices for CIP/SIP are arranged in such a way that all the surfaces can be cleaned.

A drying unit characterized in that the temperature-control systems for the heating/cooling plates can be set to the appropriate temperature under sensor control,
10 is preferred.

In a variant of the preferred drying unit, the temperature-control systems for the heating/cooling plates are regulated to the appropriate temperature predictively under the control of a computer program.

15

In a further preferred variant of the drying unit, the temperature-control systems for the heating/cooling plates are under the control of a hybrid system comprising sensor and computer and are set to the appropriate temperature.

- 20 The inventive arrangement of the heating/cooling plates produces identical mass ratios between heating/cooling plates and stand plates, and as a result approximately identical temperature/time profiles for walls and stand plates/vessels become possible.

- 25 The regulating of the heating/cooling plates is based on the following strategy:

The problem can be reduced but not completely eliminated by ensuring that the walls and the stand plates alone are at the same temperature (as described in US-A 5,398,426). Rather, during the freeze-drying the wall temperatures have to
30 substantially trap the vial temperature (Fig. 3.b), in order to virtually completely eliminate the problems. This effect is achieved by eliminating the disruptive temperature difference between chamber wall and vessel/stand plates. During the first drying section, the vessel and stand plates are not at the same temperature, and consequently a composite temperature formed from the vessel temperature and stand
35 plate temperature has to be set for the wall temperature. This composite temperature

is expediently determined with the aid of a simulation programme based on a predetermined lyocycle (temperature, pressure and time profile).

5 The solution to this object is achieved by fitting the above-described heating/cooling surfaces whose temperature can be controlled separately and which surround the stand plates on all four sides, so that a virtually continuous radiation cage is formed. Eliminating the temperature differences between heating/cooling plates and stand plates/vessel in addition prevents the formation of the disruptive free convection, together with its supply of heat to the vessels standing at the edge or to the product
10 layer at the edge of the plates, in particular during the freezing step (in which the free convection is particularly strong at ambient pressure). By contrast, during the freeze drying at low system pressures, the free convection plays much more of a subordinate role.

15 The heating-cooling plate temperature can be controlled/regulated in accordance with the following strategies:

Sensor-controlled regulation: During the freezing phase, the stand plates and heating/cooling plates are regulated in such a way that they follow the same
20 temperature programme. After the drying programme has started, the heating/cooling plate temperature and the stand plate temperature follow different programmes. The stand plate temperature is determined by the predetermined lyocycle, and the temperature/time programme which is predetermined in the lyocycle is run and regulated. In the first drying section, the temperature of the heating/cooling plates is
25 set to the sublimation temperature of the frozen product, which is dependent on the chamber pressure and the solvent. This temperature can be initially calculated approximately on the basis of the characteristics of the substances. Measurements of the sublimation temperature in laboratory experiments can be used to correct this calculated temperature. The pressure-rise method can also be used for direct
30 determination of the sublimation temperature, as described, for example, by G.W. Oetjen in "Gefriertrocknen", VCH Verlag, 1997.

The temperature of the heating/cooling plates has to be changed when the second drying section begins. The beginning of the second drying section can be detected by
35 measuring the system pressure in the gas stream coming out of the freezing chamber

using different pressure-measuring sensors, e.g.: an absolute-pressure measuring appliance and a conductivity sensor (e.g. a Pirani sensor) which is set to nitrogen. When, at the end of the first drying section, the stream of solvent vapour moves towards 0, both measured variables approach the same value, since the nitrogen
5 content in the gas stream rises continuously, and therefore the measured value from the Pirani sensor moves ever closer to the absolute-pressure measured value. The temperature of the heating/cooling plates can now slowly be raised to the temperature of the stand plates, and as the drying continues, the stand-plate temperature can be tracked. The extent to which the stand-plate temperature is
10 approached is determined, for example, as a function of the pressure difference between the two pressure indicators.

Predictive control of the heating/cooling plates: If drying profiles carried out under defined conditions at the product which is to be dried have been recorded in the
15 laboratory experiment, and this drying profile has been used to determine all the freeze-drying properties/parameters with the aid of a simulation programme, assuming that the freeze-drying properties of the freeze dryer are known, the drying profile of the product can be calculated in advance, and the values for the product temperature determined by the calculation programme can be used as a guide
20 variable for the heating/cooling plate temperatures. This method is illustrated in Fig. 3b.

Hybrid method: In this method, the product temperatures are determined from the measurements in the freeze-dryer (absolute pressure, pressure after conductivity
25 sensor) and simulation calculations, and are used as guide variable for the heating/cooling plate temperature.

The invention also relates to a method for drying moist material using a drying unit according to the invention, comprising the steps of:
30 sterilizing, if appropriate hot-sterilizing the chamber, including the unoccupied stand plates,
loading the stand plates with moist material or vessels which contain moist material,
closing the chamber opening and cooling the stand plates,
simultaneously cooling the heating/cooling plates,
35 then evacuating and passing through a temperature programme for stepwise heating

26867-6

- 8 -

of the stand plates and simultaneously gradually matching the temperature of the heating/cooling plates to the temperature of the vessels or of the moist material, introducing sterile gas into the apparatus,

5 setting the temperature of the stand plates and of the heating/cooling plates to the unloading temperature, if appropriate to ambient temperature, if appropriate closing the vessels and removing the vessels or the moist material.

In accordance with an aspect of the invention, there is provided drying unit for removing solvent from moist material, comprising at least one drying chamber having a chamber wall, at least one stand plate for holding vessels, which
10 are filled with moist material, or flat layers of moist material, the at least one drying chamber being connected to a condenser via a vapor passage, the at least one stand plate being connected to a temperature-regulated heating/cooling circuit, the at least one drying chamber having heating/cooling plates which are connected to a second heat-transfer circuit, wherein the heating/cooling plates are spaced away
15 from the chamber wall, and are connected to the chamber wall by vacuum-tight connectors and form vacuum chambers between themselves and said wall.

In accordance with another aspect of the invention, there is provided a drying unit for removing solvent from moist material, comprising at least one drying chamber with at least one stand plate for receiving vessels filled with moist
20 material or level layers of moist material, said at least one drying chamber being connected to a condenser via a vapor passageway in which the sublimated solvent can be precipitated, said at least one stand plate being connected to a first temperature-regulated heating/cooling circuit, said at least one drying chamber comprising heating/cooling plates or that are connected to a second heat carrier
25 circuit, said heating/cooling plates being implemented so as to be widely thermally decoupled from the chamber wall, wherein the heating/cooling plates are hung in the drying chamber parallel to the edges of the at least one stand plate and at a distance from said at least one stand plate so that the suspended heating/cooling plates form an almost closed radiation cage about the stack of stand plates.

26867-6

- 8a -

The novel freeze-drying apparatus is illustrated in the figures, purely diagrammatically, and explained in more detail, by way of example, below. In the drawing:

Fig. 1 shows the typical structure of a freeze-drying chamber according to the invention with condenser, stand plates and wall-integrated heating/cooling plates, which are connected to a heating/cooling circuit which can be regulated separately and the space between which, between the mechanically rigid, heavy wall structure and the heating/cooling plates, can be evacuated;

Fig. 1a shows a horizontal section through the freeze-drying chamber shown in Fig. 1 with wall-integrated heating/cooling plates;

Fig. 2 shows a variant of the freeze-drying chamber according to the invention with heating/cooling plates which are suspended vertically in front of the stand-plate stack and are connected to a heating/cooling circuit which can be regulated separately;

Fig. 3a shows the temperature curve of vessels which are positioned at the edge and in the centre of the stand plate with an unregulated wall temperature;

Fig. 3b shows the temperature curve of the vessels which are positioned at the edge of the plate and in the centre of the stand plate with the wall temperature being regulated in accordance with the invention;

Fig. 3c shows the temperature curve of the vessels which are positioned at the edge of the plate and in the centre of the stand plate when the wall temperature is regulated as described in US-A 5,398,426;

Fig. 4 shows calculations relating to the temperature curve for vessels 3 positioned at the edge and in the centre of the stand plate 2.

Examples

Fig. 1 shows a system comprising freeze-drying chamber 1 and condenser chamber 22, in which drums of product-filled vessels are frozen and freeze-dried. Fig. 1a shows vessels 3 standing on the stand plate 2 in the edge region and in the central region. The chamber 1 has two doors 11, 11a which are sealed and can be opened separately. The freeze-drying chamber 1 has a two-shell structure. The heavy chamber-wall structure 6 with reinforcing ribs 7 has the task of providing a vacuum-tight, torsionally rigid housing, which is able to withstand the atmospheric pressure when the freeze-drying chamber 1 is evacuated, for the second, inner chamber 23 which is integrated therein. The chamber 1 is provided with thermally insulating material 8 on its outer side, to prevent heat exchange with the environment. The inner freeze-drying chamber 23 is formed from the heating/cooling plates 4, which are held at a distance from the chamber wall 6 with the aid of spacers 5 and are connected to the chamber wall 6 in a pressure-tight manner by means of flexible metal sheets 9, so that the space 24 between heating/cooling plates 4 and supporting wall 6 of the chamber 1 can be evacuated. The evacuation is effected via pipelines 10, 12 which are connected to the main vacuum pump 21 via valves 20. The evacuation of the space 24 serves two purposes: firstly, pressure compensation between freeze-drying chamber 23 and the space 24 between heating/cooling plates 4 and chamber wall 6, so that compressive forces acting on the heating/cooling plates 4 are avoided. Secondly, it serves to reduce the heat exchange as a result of the pressure-dependent reduction in the effective heat conduction of the space 24. During the drying phase, the same pressure prevails in the space 24 as in the freeze-drying chamber 23 ($p < 0.1$ mbar), so that the space 24 acts in the same way as the evacuated gap of a Dewar flask. The spacers 5 between the heating/cooling plates 4 and the chamber wall 6 are made from a material with poor thermal conductivity (e.g. stainless steel), and the number of spacers 5 is kept to the minimum required, so that the heat transfer caused by heat conduction through the spacers 5 is minimized.

The connecting metal sheets 9 are designed in such a way that the temperature-dependent change in length of the heating/cooling plates 4 can be absorbed by the metal sheets without any risk to the mechanical strength of the connection to the chamber wall 6. The result is the formation of a smooth-surface freeze-drying chamber 23 which can easily be cleaned. The heating/cooling plates 4 are supplied

with heat-transfer liquid (silicone oil), which is supplied via the line 1. and discharged via the line 14, by means of a temperature-control system (not shown) which can be regulated separately. The temperature-control system uses the same heat-transfer medium as the stand plates and can be supplied from the same
5 reservoir. The temperature-control system for the heating/cooling plates 4 fundamentally has to be operated at a temperature which is matched to the vial temperature, while the heat-transfer medium for the stand plates 2 follows a different temperature programme, which follows the lyocycle.

10 The temperature programme for the heating/cooling plates 4 depends on the temperature of the vessels. This method has already been described in general terms above.

Example 2

15

Fig. 2 shows an embodiment of the freeze-dryer which differs in terms of the way in which the heating/cooling plates 4' are arranged. In this case, the temperature-controlled plates 4' are suspended freely in the chamber 23. The heating/cooling plates 4' are suspended parallel to and at a distance from the edges of the standing
20 plates 2, so that space is retained for all the equipment associated with the stand plates 2, for example hoses 25, 26 for the heat-transfer medium, stand-plate holders (not shown).

Known CIP/SIP features (automatic cleaning and sterilization systems) may
25 additionally be provided in the interior of the chamber. The heating/cooling plates 4' are in turn fed with the heat-transfer medium from a separate heat-transfer circuit via inlet 13 and return 14. The mass of the heating/cooling plates in both embodiments (in accordance with Examples 1 and 2) corresponds to the mass of the stand plates 2, so that the heating/cooling dynamics of the plates 2 and 4 or 4' are also matched to
30 one another and there are no shifts in the temperature caused by uneven masses.

Calculations relating to the temperature curve:

Calculations have been carried out in connection with the temperature curve in a number of variants of the freeze-drying device, and these calculations are reproduced in the diagrams shown in Fig. 3a to 3c and 4.

5 Fig. 3a shows the temperature curve of the vessels which are positioned at the edge and in the centre of the stand plate, without the wall temperature being regulated; in this figure, the abbreviations have the following meanings:

a unregulated wall temperature

b stand plate temperature

10 c edge vessel temperature

d centre vessel temperature

the indices 1 in this diagram and in those which follow represent the temperature at a cake height of 1 mm in the material being dried, and the indices 6 represent the temperature at a cake height of 6 mm in the material being dried;

15

Fig. 3b shows the temperature curve of the vessels which are positioned at the edge of the plate and in the centre of the stand plate, with the wall temperature being regulated in accordance with the invention; in this figure, the meanings of the abbreviations are as follows:

20

a regulated wall temperature

b stand plate temperature

c edge vessel temperature

d centre vessel temperature;

25

Fig. 3c shows the temperature curve of the vessels which are positioned at the plate edge and in the centre of the stand plate when the wall temperature is being regulated in accordance with US-A 5,398,426; in this figure, the abbreviations have the following meanings:

30

a regulated wall temperature

b stand plate temperature

c edge vessel temperature

d centre vessel temperature.

It immediately becomes clear from the diagrams that when the apparatus according to the invention with regulated wall temperature is used, the temperature characteristics of the vessels at the edges are substantially the same as the characteristics of the vessels arranged at the centre of the stand plate (Fig. 3b), while
5 when conventional facilities are in operation there are considerable differences in the temperature profile (Fig. 3a); the same is true when the wall temperature is regulated in accordance with US-A 5,398,426 (Fig. 3c).

Figure 4 presents the data from an experiment carried out in a 1 m² pilot freeze-dryer
10 (1 m² standing surface area). All the thin, continuous lines are measured values. The thick continuous lines are calculated values. The temperature curves for vessels 3 which are positioned at the edge of the plate and temperature curves for vessels 3 which were arranged in the centre of the plate – well away from the wall and protected by the adjacent vessels – were compared. The calculated temperature
15 curves distinguish between two situations:

- for the vials arranged in the centre, no heat transfer through the radiating wall is taken into account,
- for the vials positioned at the edge, all the heat exchange with the wall is taken
20 into account.

The wall itself exchanges heat with the stand plates 2 and the environment and is therefore taken into account as a factor which varies over the course of time. The extent to which the calculated temperatures coincide with the measured temperatures
25 can be considered satisfactory if the difficulties of measuring the temperature in the vessels is taken into account. It can be seen from this measurement and the evaluation by the simulation programme that when the driving temperature potential between wall and stand plates 2 is eliminated, the vessels 3 located at the edges will also follow the temperature curve of the vessels in the centre, as calculated for a
30 different case in Fig. 3b; in Fig. 4, the abbreviations a to g have the following meanings:

- a stand plate temperature
- b calculated wall temperature
- b_{1,2,3} measured wall temperatures
- 35 c chamber pressure (measured)

- d centre vessel temperature (measured)
- e centre vessel temperature (calculated)
- f edge vessel temperature (measured)
- g edge vessel temperature (calculated).

26867-6

- 15 -

CLAIMS:

1. A drying unit for removing solvent from moist material, comprising at least one drying chamber having a chamber wall, at least one stand plate for holding vessels, which are filled with moist material, or flat layers of moist material,
5 the at least one drying chamber being connected to a condenser via a vapor passage, the at least one stand plate being connected to a temperature-regulated heating/cooling circuit, the at least one drying chamber having heating/cooling plates which are connected to a second heat-transfer circuit, wherein the heating/cooling plates are spaced away from the chamber wall, and are connected
10 to the chamber wall by vacuum-tight connectors and form vacuum chambers between themselves and said wall.
2. The drying unit according to claim 1, wherein the chamber wall is sufficiently pressure-resistant to enable the chamber to be evacuated without deformation or fracture of said wall.
- 15 3. The drying unit according to claim 1, wherein the chamber wall is provided with thermal insulation.
4. The drying unit according to claim 1, wherein the heating/cooling plates are mechanically connected by spacers to the inner side of the chamber wall, with which they form planar gaps which defines said vacuum chambers,
20 which can be evacuated, vacuum connections being provided through the chamber wall.
5. The drying unit according to claim 1 or 4, further comprising a vacuum system, wherein the pressure within the vacuum chambers is adjustable to the pressure level of the drying chamber by said vacuum system.
- 25 6. The drying unit according to claim 4, wherein the spacers have a low thermal conductivity.
7. The drying unit according to claim 6, wherein said spacers are stainless steel spacers.

26867-6

- 16 -

8. The drying unit according to claim 1, comprising flexible metal connecting sheets between lateral heating/cooling plates and the chamber wall which are sufficiently flexible to compensate for thermal expansion and contraction of the heating/cooling plates without damage.
- 5 9. The drying unit according to claim 1, wherein said at least one stand plate is a stack of stand plates and heating/cooling plates are suspended in the drying chamber parallel to the edges of the at least one stand plate and are spaced away from the at least one stand plate, to form a virtually continuous radiation cage around the stack of stand plates.
- 10 10. The drying unit according to claim 1, wherein the at least one drying chamber is adapted to be evacuated.
11. The drying unit according to any one of claims 3, 9 and 10, wherein the chamber wall is provided with an outer thermal insulation.
12. The drying unit according to any one of claims 1, 9, and 10 further
15 comprising cleaning-in-place/sterilization-in-place (CIP/SIP) cleaners disposed to clean all the surfaces of the drying unit.
13. The drying unit according to claim 1, wherein the heating/cooling plates are temperature controlled, and the temperature-control systems for the heating/cooling plates incorporate sensor control.
- 20 14. The drying unit according to claim 1, wherein the heating/cooling plates are temperature controlled, and the temperature control systems for the heating/cooling plates incorporate a predictive computer control program.
15. The drying unit according to claim 1, wherein the heating/cooling
25 heating/cooling plates incorporate a hybrid control system comprising sensor and computer.

26867-6

- 17 -

16. A method for drying moist material using the drying unit of claim 1, comprising the steps of:

sterilizing, the at least one drying chamber, including the at least one stand plate,

5 loading the at least one stand plate with moist material or vessels which contain moist material,

closing the at least one chamber and cooling the at least one stand plate,

simultaneously cooling the heating/cooling plates,

10 then evacuating and carrying out a temperature program for stepwise heating of the at least one stand plate and simultaneously gradually matching the temperature of the heating/cooling plates to the temperature of the vessels or of the moist material,

introducing sterile gas into the at least one drying chamber,

15 setting the temperature of the at least one stand plate and of the heating/cooling plates to a desired unloading temperature, optionally to ambient temperature, optionally closing the vessels, and removing the vessels or the moist material.

17. The method of claim 16 wherein sterilizing the at least one chamber
20 comprises hot sterilizing.

18. A drying unit for removing solvent from moist material, comprising at least one drying chamber with at least one stand plate for receiving vessels filled with moist material or level layers of moist material, said at least one drying chamber being connected to a condenser via a vapor passageway in which the
25 sublimated solvent can be precipitated, said at least one stand plate being connected to a first temperature-regulated heating/cooling circuit, said at least one drying chamber comprising heating/cooling plates or that are connected to a

26867-6

- 18 -

second heat carrier circuit, said heating/cooling plates being implemented so as to be widely thermally decoupled from the chamber wall,

wherein the heating/cooling plates are hung in the at least one drying chamber parallel to the edges of the at least one stand plate and at a distance from said at least one stand plate so that the suspended heating/cooling plates form an almost closed radiation cage about the stack of stand plates.

19. The drying unit as set forth in claim 18 wherein the heating/cooling plates are spaced away from the chamber wall.

20. The drying unit as set forth in any one of claims 18-19 wherein the heating/cooling plates are connected in vacuum-tight fashion to the chamber wall.

21. The drying unit as set forth in any one of claims 18-20 wherein the heating/cooling surfaces are mechanically connected to an inner side of the chamber wall via spacers and form with said inner side of the chamber wall a level gap that may be evacuated, thereby providing vacuum connections in the chamber wall.

22. The drying unit as set forth in any one of claims 18-21 wherein the gap is adjustable to the pressure level of the drying chamber via a vacuum system for the purpose of pressure equalization.

23. The drying unit as set forth in any one of claims 18-22 wherein the spacers are made from a material having poor heat-conducting properties.

24. The drying unit of claim 23 wherein the material having poor heat-conducting properties is stainless steel.

25. The drying unit as set forth in any one of claims 18-24 wherein elastic connecting sheets between lateral heating/cooling plates and the chamber wall are configured to be so flexible that temperature-related length variations of the heating/cooling surfaces are compensated without damage to the material.

26867-6

- 19 -

26. The drying unit as set forth in any one of claims 18-25 wherein the at least one drying chamber is adapted to be evacuated during the freezing process in order to reduce convection influences.
27. The drying unit as set forth in any one of claims 18-26 wherein
5 devices for CIP/SIP are mounted so that all the surfaces can be cleaned.
28. The drying unit as set forth in any one of claims 18-27 wherein temperature-control systems for the heating/cooling plates can be set to the appropriate temperature under sensor control.
29. The drying unit as set forth in any one of claims 18-28 wherein the
10 temperature-control systems for the heating/cooling plates can be set predictively to the appropriate temperature under control of a computing program.
30. The drying unit as set forth in any one of claims 18-27 wherein the temperature-control systems for the heating/cooling plates can be set to the appropriate temperature through a hybrid system consisting of sensor and
15 computer.

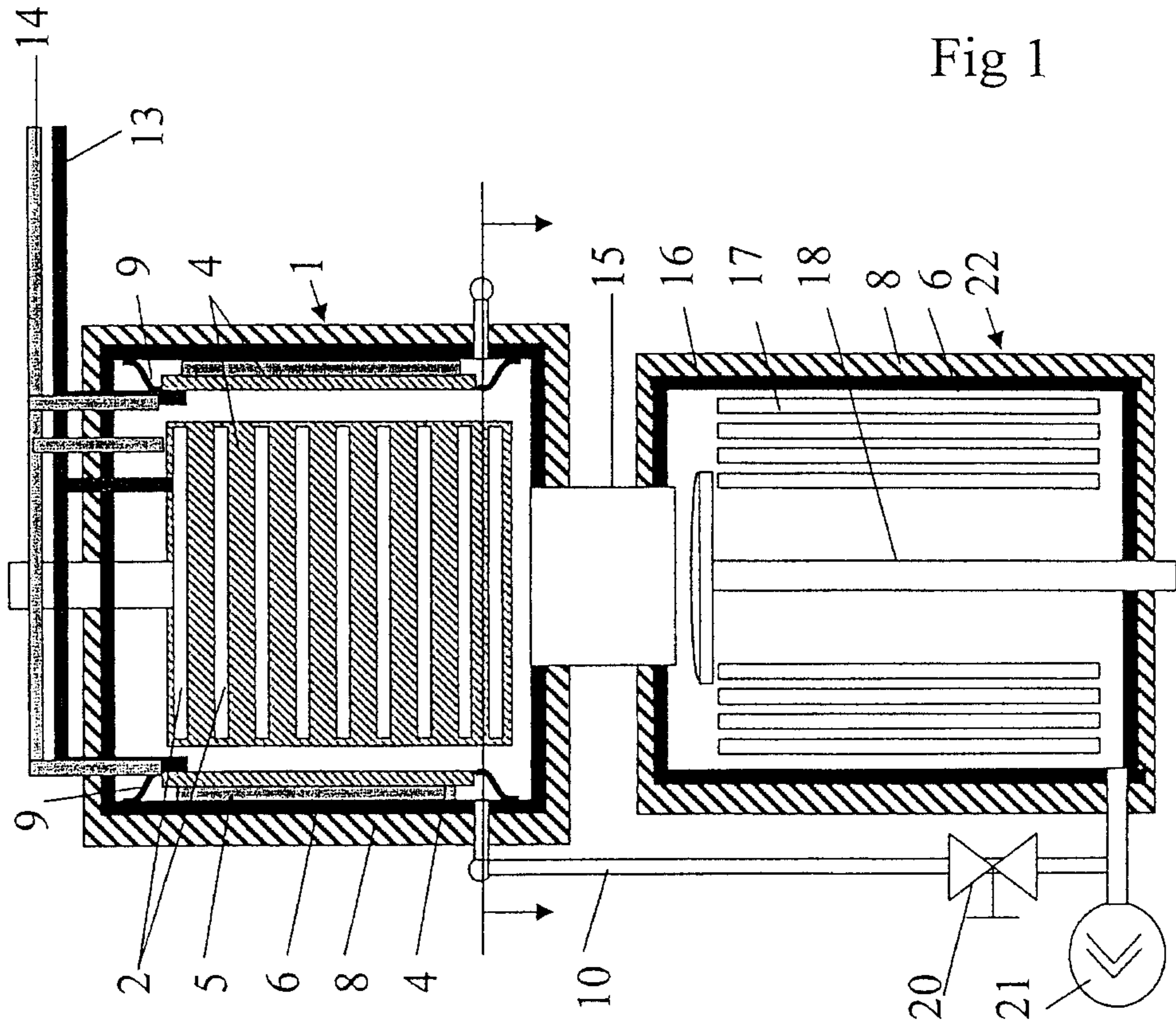
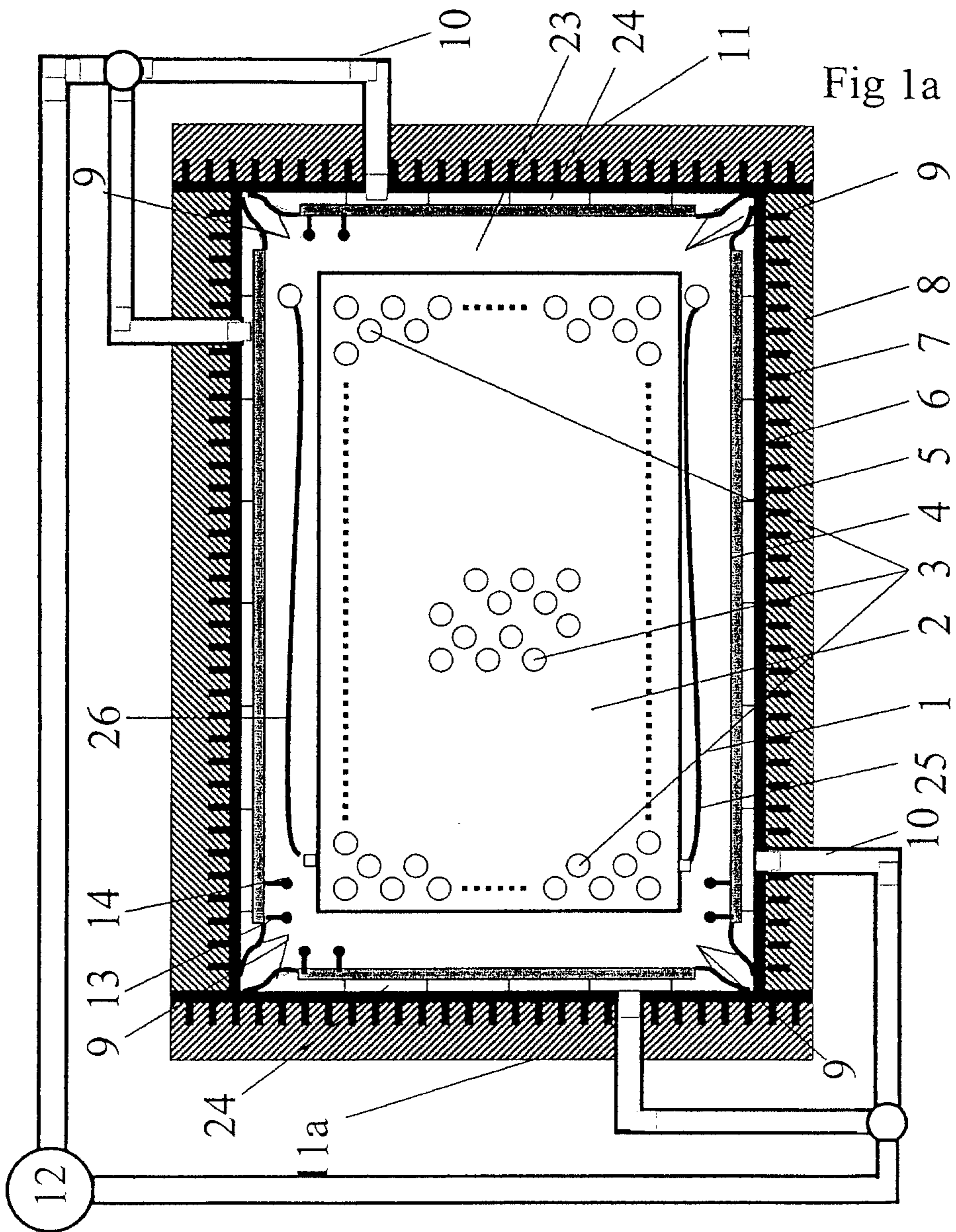
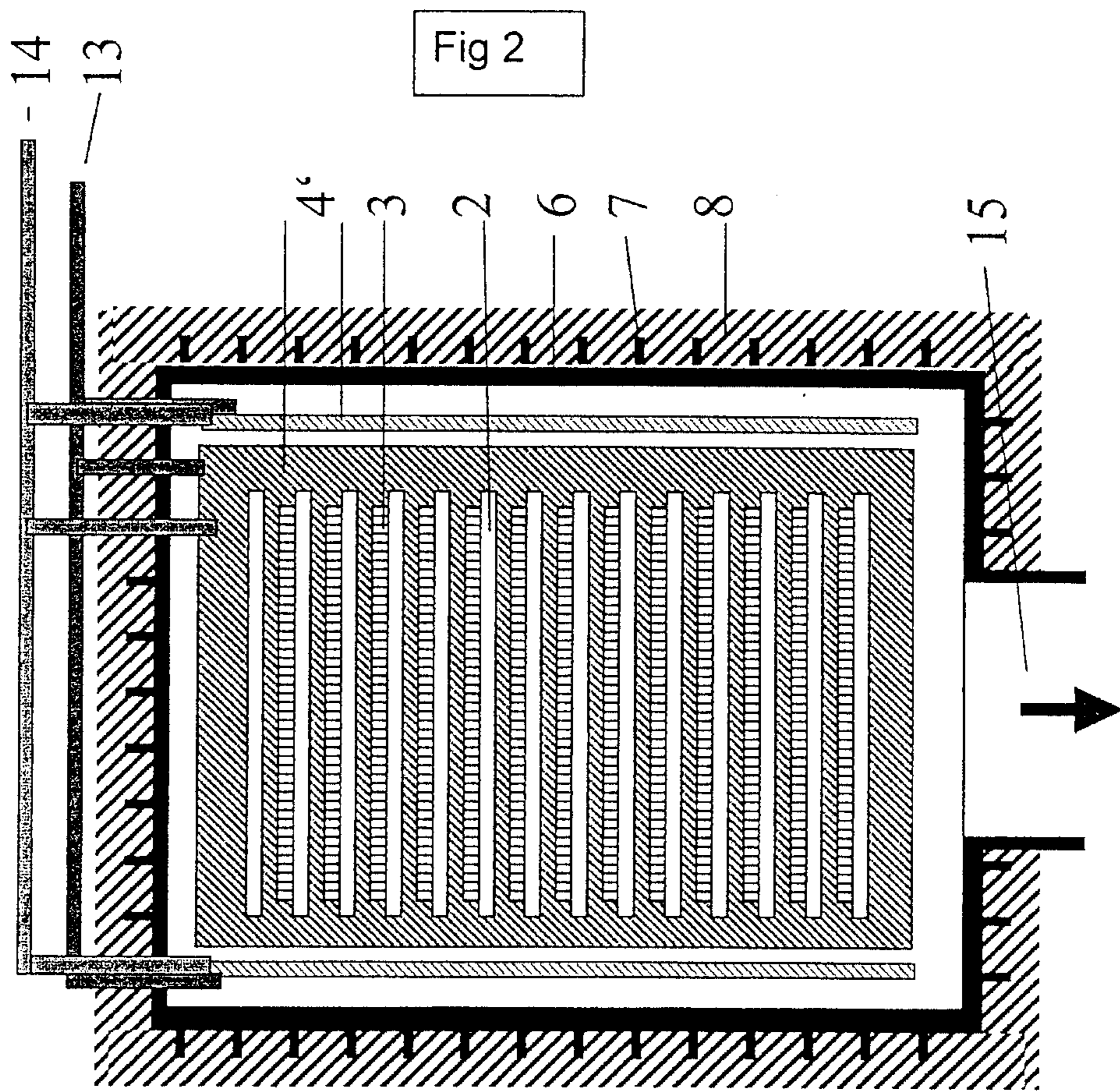

Fig 1





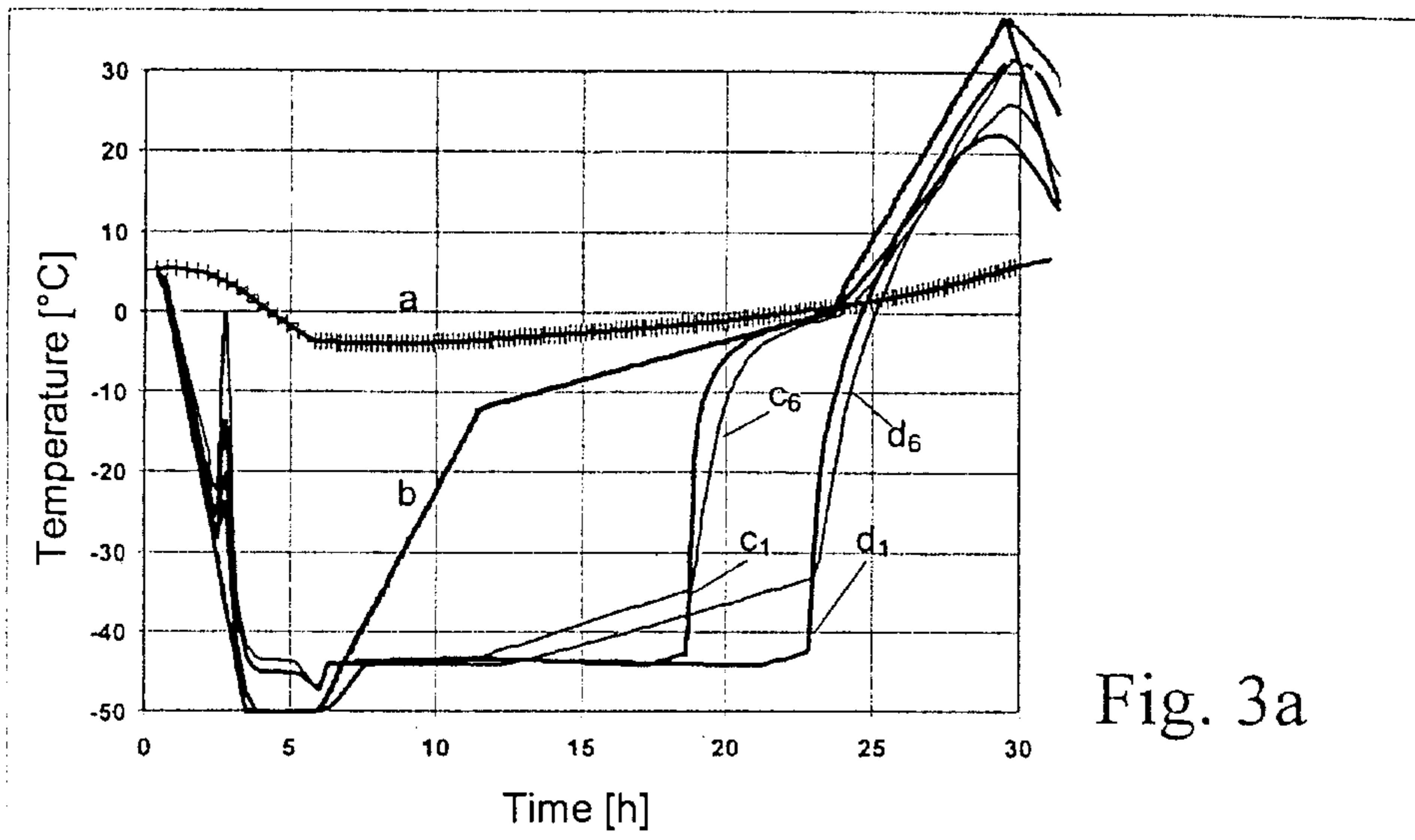

Fig. 3a

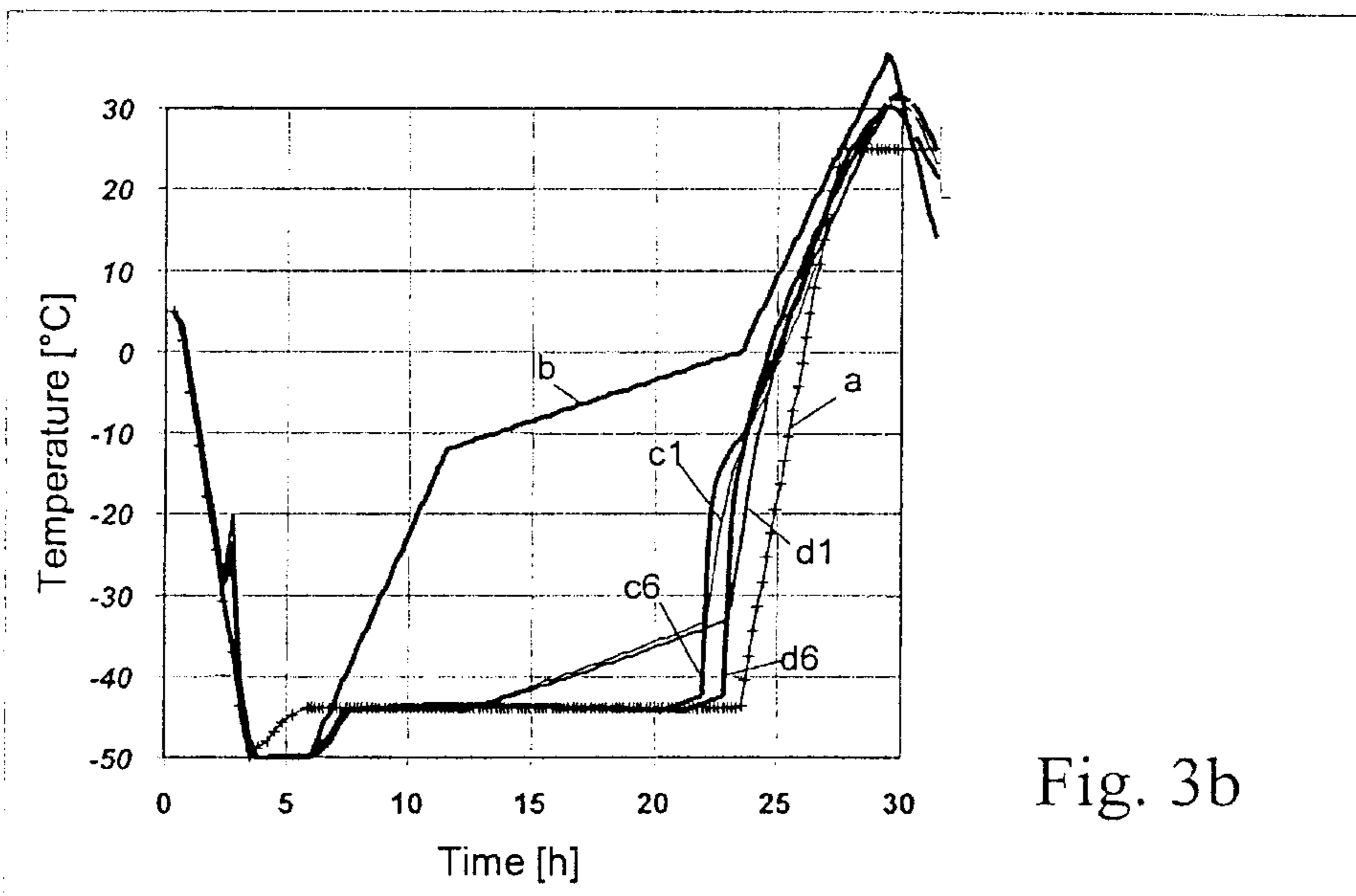

Fig. 3b

