

No. 666,837.

Patented Jan. 29, 1901.

R. WITTMANN.
CYCLE.

(Application filed July 13, 1899.)

2 Sheets—Sheet 2.

(No Model.)

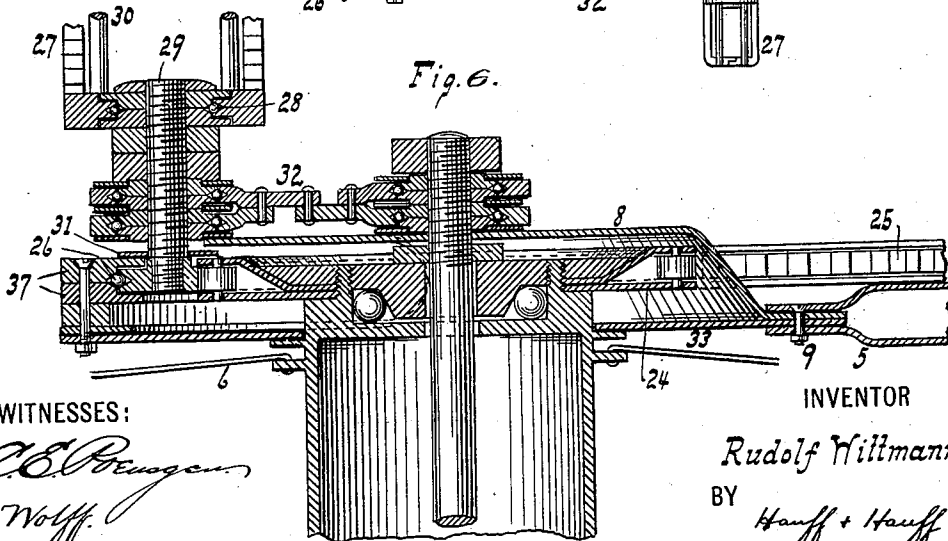
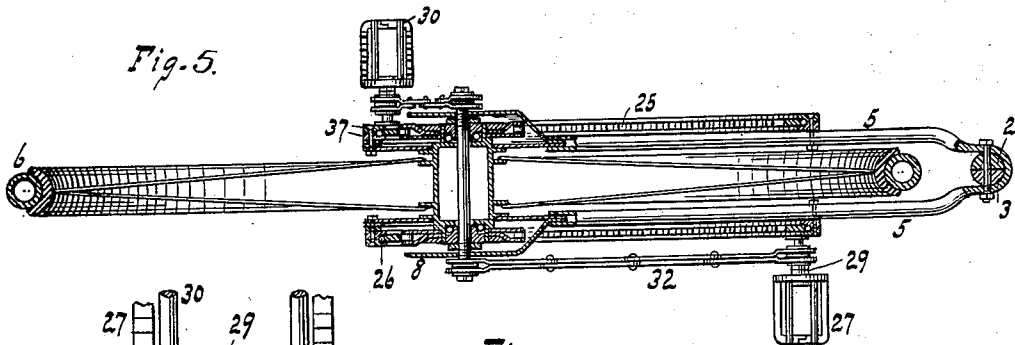
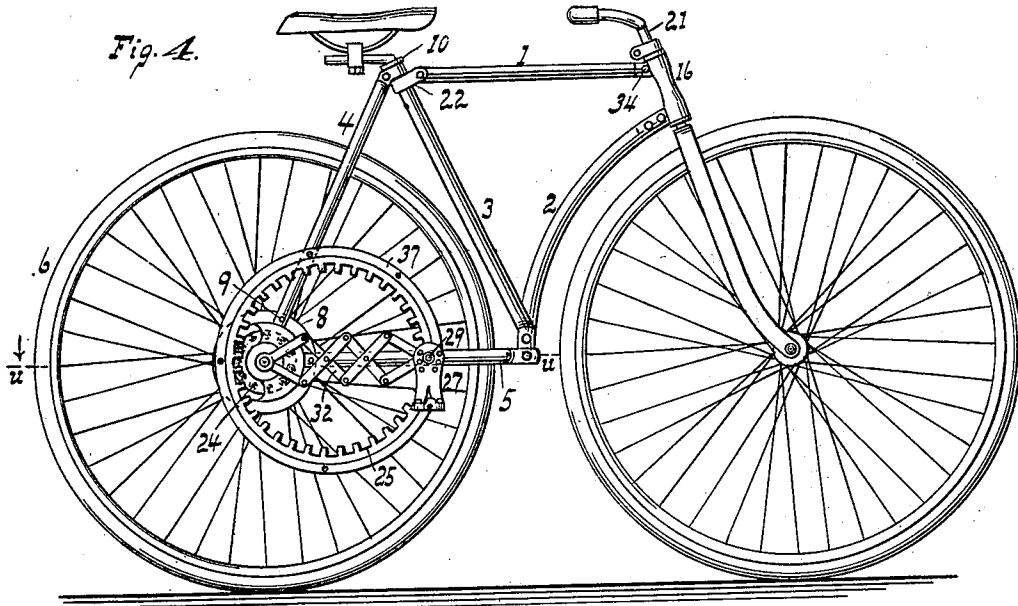

WITNESSES:

C. C. Pruzger
E. Wolff

INVENTOR

Rudolf Wittmann
BY
Hauff + Hauff
ATTORNEYS

UNITED STATES PATENT OFFICE.

RUDOLF WITTMANN, OF NEW YORK, N. Y.

CYCLE.

SPECIFICATION forming part of Letters Patent No. 666,837, dated January 29, 1901.

Application filed July 13, 1899. Serial No. 723,733. (No model.)

To all whom it may concern:

Be it known that I, RUDOLF WITTMANN, a citizen of the United States, residing at New York, (Brooklyn,) in the county of Kings and State of New York, have invented new and useful Improvements in Cycles, of which the following is a specification.

This invention relates to a cycle of simple construction and reliable and easy in operation or propulsion; and the invention resides in the novel features of construction set forth in the following specification and claims and illustrated in the annexed drawings, in which—

Figure 1 is a side elevation of a cycle embodying my invention. Fig. 2 is a section along *v v*, Fig. 1. Fig. 3 shows the gear-ring running against antifriction-rollers. Fig. 4 shows a modification. Fig. 5 is a section along *u u*, Fig. 4. Fig. 6 shows the pinion and gear, the latter running against antifriction-balls instead of rollers, as in Fig. 3.

In the drawings is shown a cycle or vehicle frame, of which the branch or section 1 is conveniently called the "top" branch, and 2 the "front" branch. The intermediate section or seat-post branch is shown at 3, the rear branch or stays at 4, and the lower branch or bottom stays at 5. The rear branch is forked to straddle or extend at both sides of rear wheel 6. The branches 4 and 5 are secured by fastenings or bolts 9 to disks 8, forming a bearing for the rear wheel 6 or for its axle or hub. The headpiece 16 has the steering-post 21 extended therethrough, and the top branch 1 is secured to the headpiece and to section 3 at the points 34 and 22. When the top branch is in drop-frame position, a steadying or brace piece 23 can be applied, as seen in Fig. 1. The intermediate tube 3 has a shoulder 10 sitting on the branch 4. The cycle-wheel 6 has on its hub or axle a pinion or sprocket-wheel 24. For easy running this pinion can have antifriction-rollers carried by its teeth, Fig. 6. A ring 25, Fig. 4, has teeth on its inner rim, such internally-toothed ring meshing with the pinion 24, sitting in such ring. The outer edge of the ring sits against balls 26, Figs. 5 and 6, so as to rotate easily. The race for these balls is formed by the sections 37, which when separate allow the balls and ring to be put

in place. When secured together and fastened to frame-sections 4 and 5, the race-sections 37 retain the balls 26 and ring 25. The centers of pinion 24 and ring 25 are on a horizontal line or on the line of the lower frame-section 5. A pedal 27 on the ring 25 allows the latter to be rotated to drive pinion 24 and wheel 6. The pedal 27 is made to work easy by the ball-bearings 28, Fig. 6, about pin 29, supporting the pedal and extended from ring 25. The pedal is shown with eyes, into which can be placed one or more studs 30 to form toe-clips. The pedal being made of one piece of material is strong and durable. A cover or plates 31, Fig. 6, sitting close to pin 29 on race 37 and ring 25, will act as a dust-guard to protect the balls 26 and teeth of pinion 24. The ring can be formed as a wheel, Fig. 1, mounted on an axle; but the race 37 alone is sufficient to rotatively support the ring, so that the latter can have its inner part entirely open or formed without hub or spokes and supported merely at its rim running in race 37. When the ring 25 is in form of a wheel, as seen in Fig. 2, the free or outer edge of the wheel or rim is doubled or bent inward or toward the center to bring the teeth on this rim to mesh with the pinion or sprocket 24, situated inside the periphery of wheel 25. The center points of pinion 24 and of the surrounding gear 25 are both shown on the horizontal or lower frame-section 5. Lazy-tongs 32 form an extensible connection between the axle of pinion 24 and the pedal 27. The lazy-tongs is shown in Fig. 4, but can be omitted, as seen in Fig. 1, or replaced by a sliding link.

In place of balls 26, as seen in Fig. 6, a set of suitably-spaced rollers 26', Fig. 3, having their axles supported on bearing ring or plate 37', could be employed. As a large number of balls 26 are required to make a filling around the race and weight is thus added to the device, a few suitably-spaced rollers 26' may be considered preferable and need not be excessively heavy.

No claim is made in this application to the construction of the frame or pedal of the device.

What I claim as new, and desire to secure by Letters Patent, is—

1. A cycle-wheel, a pinion on the hub of the wheel, a toothed ring made to surround and to mesh with the pinion, a pedal on the ring, and a movable connection or lazy-tongs
 5 connected to the wheel hub or axle and to the pedal substantially as described.

2. A cycle-wheel, gear-rings on opposite sides of and geared to the wheel, and pedals directly and pivotally attached to and sus-
 10 pended from the periphery of the rings substantially as described.

3. A cycle-wheel having a pinion fixed directly thereto, a driving-ring made to surround the pinion and a pedal directly and
 15 pivotally attached to and suspended from the

periphery of the ring, substantially as described.

4. A cycle-wheel having its axle provided with a pinion, a gear-ring about the pinion, a pedal on the ring, and a lazy-tongs connec-
 20 tion between the axle and pedal, substantially as described.

In testimony whereof I have hereunto set my hand in the presence of two subscribing witnesses.

RUDOLF WITTMANN.

Witnesses:

W. C. HAUFF,
 C. E. POENSGEN.