



Europäisches Patentamt
European Patent Office
Office européen des brevets



(11) **EP 0 795 657 B1**

(12) **EUROPEAN PATENT SPECIFICATION**

(45) Date of publication and mention
of the grant of the patent:
24.10.2001 Bulletin 2001/43

(51) Int Cl.7: **E04B 9/30**

(21) Application number: **97301649.6**

(22) Date of filing: **12.03.1997**

(54) **A ceiling mounting system**

Hängedeckenbauweise

Système de montage pour plafonds suspendus

(84) Designated Contracting States:
BE DE ES FR GB IT NL

• **Horsten, Antonius J.J.**
2555 NC The Hague (NL)

(30) Priority: **14.03.1996 EP 96301767**

(74) Representative: **Allen, William Guy Fairfax et al**
J.A. KEMP & CO.
14 South Square
Gray's Inn
London WC1R 5JJ (GB)

(43) Date of publication of application:
17.09.1997 Bulletin 1997/38

(73) Proprietor: **HUNTER DOUGLAS INDUSTRIES B.V.**
3071 EL Rotterdam (NL)

(56) References cited:
EP-A- 0 516 330 **FR-A- 2 627 527**
NL-A- 9 301 668 **US-A- 4 715 161**

(72) Inventors:

- **Brugman, Johannes A.H.**
3351 VH Papendrecht (NL)

EP 0 795 657 B1

Note: Within nine months from the publication of the mention of the grant of the European patent, any person may give notice to the European Patent Office of opposition to the European patent granted. Notice of opposition shall be filed in a written reasoned statement. It shall not be deemed to have been filed until the opposition fee has been paid. (Art. 99(1) European Patent Convention).

Description

[0001] The present invention relates to a ceiling mounting system which can be used for mounting a ceiling suspended from a number of longitudinal carriers which span a room. Typically this is a false ceiling made up of ceiling panels.

[0002] A mounting system of this general type is shown in document NL 71/07,694. A number of longitudinal room carriers span the room area and are connected at their ends to perimeter support members which are fixed at a constant height around the entire perimeter of the room. The spans of the longitudinal room carriers are supported in the middle by hanger arrangements which are themselves suspended from the actual ceiling of the room. The perimeter support members are secured to the walls by suitably placed screws. The false ceiling is then suspended from the longitudinal room carriers and perimeter support members.

[0003] The main disadvantage with this standard system is in its inflexibility. This stems from the fact that it is intended for installation by a skilled user who installs such systems on a frequent basis. Thus standard systems are fine when the quality of a wall is good enough to support fixings at the exact height where the perimeter carrier member is intended, where it is possible to drill holes at that height, and where the quality of workmanship is good enough to ensure that the perimeter support members at least are level. These are the conditions usually prevalent in brand new constructions and that is the market when the standard systems are pitched. However, there are times when fixings are required at positions where the quality of a wall is not good enough, or where it is inconvenient to drill. Also, drilling holes in stone or concrete structures with the required accuracy is time consuming. Even when great care is taken it is often easy for errors to be made in the actual drilling. Further, with the same time pressures associated with installing pre-fabricated, mass produced metal structures the accuracy tends to suffer. As a result one cannot always rely on pre-provided screw holes in carrier beams, mistakes are made when holes are not pre-provided and frequent re-drilling of holes is required to correct misalignments or inaccuracies.

[0004] US-A-4,715,161 describes a semi-adjustable system which uses wall brackets having barbs to catch a top edge of a wall profile at one of several positions. The brackets also have means to support and engage cross spars, but not at adjustable heights.

[0005] Another problem associated with the prior art is that the hanger arrangements must, themselves, be accurately placed so that they can support room carriers immediately beneath them. If a hanger is misplaced, it must be repositioned. Sometimes it simply is not possible to put a hanger in its ideal position.

[0006] Further disadvantages are that the carrier members are frequently too long for domestic use and must be cut down and that the user is often left to himself

to decide where to put the hanger arrangements.

[0007] It is an aim of the individual aspect of the present invention to alleviate these problems at least partially.

[0008] According to one aspect of the present invention there is provided a mounting system for supporting a ceiling, comprising:

a perimeter profile
at least one mounting bracket for mounting to a fixed support and adapted to receive and mount said perimeter profile; and
engagement means positioning the perimeter profile relative to the mounting bracket in at least a first direction;

characterized in that;

said engagement means comprises a clip on said at least one mounting bracket, which clip in a first mode prevents motion of said perimeter profile relative to said at least one mounting bracket in a second direction opposed to said first direction while allowing relative movement in said first direction and in that said clip in a second mode prevents relative movement of said perimeter profile in said first and second directions.

[0009] The present invention also contemplates a ceiling support system comprising the above mounting system and a splicing bracket for splicing together the ends of two carrier members of a room carrier, the splicing bracket comprising:

engaging means adapted to engage and support said two ends in alignment with each other; and
bracket support means whereby said splicing bracket and any engaged carrier member or members can be supported from above, said bracket support means comprising a bracket hook or a bracket loop.

[0010] The present invention further contemplates a ceiling hanging system comprising the above mounting system or the above support system and a hanger arrangement for supporting a room carrier between the carrier's two ends, the hanger arrangement comprising:

a ceiling bracket for fastening to a ceiling by fastening means;
a rod depending from said ceiling bracket; and
carrier supporting means for supporting a room carrier therefrom, adjustably mounted on said rod for relative rotational motion and motion along said rod; characterized in that
said ceiling bracket has a closed-ended slot for insertion therethrough of said fastening means, for rotating-motion and sliding-motion there between; and
said rod is screw threaded.

[0011] The present invention will be further described, by way of example only, with reference to the accompanying drawings, in which:-

Figure 1 is a perspective view of a first embodiment of the invention in use;

Figures 2a, 2b and 2c is a sequence of figures showing, in cross-section, features of the embodiment of Figure 1;

Figure 3 is a perspective view of the perimeter profile of Figures 1 and 2 supporting a longitudinal room carrier;

Figure 4 is a perspective view of a perimeter carrier according to a second embodiment of the invention; Figure 5 is a view of the perimeter carrier of the second embodiment in cross-section with a longitudinal room carrier; and

Figure 6 is a perspective view of an intermediate hanger arrangement for a longitudinal room carrier, according to a third embodiment of the invention.

[0012] According to the first embodiment of the invention, as shown in Figure 1, mounting means comprising a plurality of wall brackets 4 are secured to a wall 2 at spaced intervals. The wall brackets in turn support perimeter profiles, in this case wall profiles 6, which are used for supporting longitudinal room carriers or other room carriers. For added stability corner connectors 8 can be used to connect the wall profiles 6 at the corners.

[0013] The successive stages of mounting a wall profile 6 are illustrated in three Figures, 2a, 2b and 2c.

[0014] The wall profile 6 has a vertically extending toothed portion 20 with a series of downward pointing ratchet teeth 24 along its length. A carrier support portion, in this case horizontally extending elongate ledge 22 is provided to support the ends of longitudinal room carriers. A further portion extends downwardly from the base of the toothed portion 20 as an edge cover support portion 26, the top of which has an edge cover retaining portion 28.

[0015] The wall bracket 4 includes a detent portion, in this case a locking spring clip 10. This has an upwardly angled detent or pawl 30 for catching on the ratchet teeth 24 of the toothed portion 20 of the wall profile 6. When a handle 32 of the spring clip 10 is in the position shown in Figure 2a then the pawl 30 is able to pivot back and forth. This is as indicated by arrow 31 in Figure 2b where, as the wall profile 6 is pushed upwards, the sloped surfaces of its teeth 24 push the sloped surface of the pawl 30 away. In this fashion the wall profile 6 is allowed to move upwards as indicated by arrow 21. However, the spring clip 10 is provided with a locking detent 34 which is able to clip onto a portion of the wall bracket 4 in order to hold the spring clip 10 and the pawl 30 in a locking position. Then the wall profile 6 is prevented from moving up or down.

[0016] The specific steps of the mounting of this mounting system will now be explained. Firstly, one or

more wall bracket 4 is fixed onto a wall 2, using a screw, bolt or other suitable method. The number of wall brackets 4 and spacing between adjacent wall brackets 4 is determined by the required profile length, the load to be suspended from the brackets 4 and also by such matters as proximity of a bracket 4 to the end of a wall 2 or carrier profile 6.

[0017] The wall brackets 4 do not need to be mounted at a uniform height, and therein lies a significant advantage over the prior art. They do, however, need to be mounted within a vertical range corresponding to the length of the toothed portion 20 of the wall profile 6. In that way all the wall profiles 6 can be adjusted to the same height on the wall 2. Once the wall brackets 4 have been mounted, or at least one has been mounted, then a wall profile 6 can be attached to it or them. The leading end of the toothed portion 20 is inserted into the underside of the wall bracket 4 and using its sloping leading edge pushes the pawl 30 in an anti-clockwise direction. Once the leading tooth has passed the pawl 30 then the pawl 30 will pivot back in a clockwise direction to below the leading tooth. Arrow 31 indicates this movement. The whole of the wall profile 6 is then able to hang from the leading tooth and pawl 30. If the wall profile 6 is not at the right height at that stage then, as shown in Figure 2b, it may be pushed upwards in the direction of arrow 21 to whatever height is desired, so that the profile is at the same height as any other profiles in the room, so that the ceiling may be flat (or sloped if intended). A spirit level or other device can be used to ensure that the profiles about the room are all straight and are at the correct level. Once a profile 6 is at the correct position, the locking spring clip 10 is rotated by the handle 32 in the direction of arrow 33 so that the locking detent 34 can lock it in position. Once this has been done further upward force on the wall profile 6 will not move it.

[0018] In this way several wall brackets 4 can be fixed at slightly different levels, for whatever reason, while one or more wall profiles 6 can finally be fixed at a correct position at the desired level.

[0019] The engagement means of the perimeter profile and mounting means is shown in Figures 1 and 2 as an elongate series of ratchet teeth 24 and a spring clip 10. Other arrangements using a toothed portion and a detent are possible, as are arrangements which use completely different systems, such as providing the profile with an elongate member with holes in it, instead of the toothed portion, and using a pin to keep it in position.

[0020] The locking aspect of the detent (locking spring clip 10 in the described embodiment) is not essential either. In the described embodiment the pawl 30 is in a stable enough position to support the profile, room carriers and any ceiling suspended therefrom. The locking feature merely ensures that the profile cannot, accidentally, be pushed further upwards.

[0021] The locking spring clip shown in Figures 2a to 2c could be replaced with any of a number of other systems having a similar effect. For instance the pawl 30

could be rotated about a very much nearer axis and not extend beyond it. It could be biased to engage the toothed portion, for instance, using a separate spring. If necessary, some form of bolt could be used to lock it in its engagement position with the toothed portion.

[0022] For added strength a plurality of pawls could be used. As a further alternative the pawl could be replaced with a wheel, which only rotates in one direction and is locked, for instance by another wheel or pawl against rotation which allows the perimeter profile to move downwards.

[0023] As yet another alternative, the toothed portion of the perimeter profile could be replaced with a pawl, or other detent and the series of teeth be provided in the wall bracket.

[0024] In the embodiment shown in Figure 1 the handle 32 can be pulled in an anti-clockwise direction to disengage the pawl 30 from the toothed portion 20. This then allows the profile 6 to move downwards, should it become necessary. In any alternative embodiment an action which allows a similar effect is preferable. This may involve pulling out a pin, pushing a pawl against a spring, etc.

[0025] The toothed portion 20 preferably extends along the whole length of the profile so that it does not matter whereabouts along its length it encounters the wall bracket(s) 4.

[0026] As an alternative to the toothed portion 20 extending along the length of the perimeter profile 6, the profile could instead be provided with an appropriate number of toothed portions (or detent portions) of a limited width, but which are moveable along at least part of the length of the profile 6 to a position or positions where it or they will each encounter a wall bracket or wall brackets. It would be preferable for such moveable portions to be capable of being fastened in place for added stability.

[0027] In the described embodiment the mounting means is one or more mounting brackets fastened directly to the wall. As an alternative method of mounting the wall brackets they themselves could be adjustably mounted on a elongate mounting unit extending along a length of a wall, if not the majority or even substantially all of it. This might be useful for instance where a wall is of insufficient strength to take the weight of the mounting in the middle, or when the wall does not exist and all that is needed is a perimeter. The mounting brackets could then be slid along the bar or removably fastened at different positions etc. This system could be used with profiles of constant cross-section, as shown in the Figures, or with profiles whose toothed portion(s) (or detent portion(s)) is or are of limited extent.

[0028] Figure 3 shows the wall profile of Figure 1 together with a longitudinal room carrier 12. The wall bracket 4 is not present in the drawing for ease of understanding but would be present in a real situation.

[0029] Longitudinal room carriers 12 normally extend from one wall of a room to another, usually across the

middle. A room carrier 12 typically includes at least one carrier member 44 and a carrier end portion 40 at one or both of its ends. Each carrier end portion 40 is supported on a room carrier support portion, in this example the elongate ledge 22 of the wall profile 6. The carrier end portion 40 can be supported at any point along the length of the profile 6 and, whilst normally extending at right angles to the profile 6 may, instead, extend at almost any other angle in the horizontal or vertical planes. The end portion 40 is inserted into the end of the end-most carrier member 44 of the room carrier 12 and is fastened in position by a nut and bolt 42. The extent to which the end portion 40 projects from the end of the room carrier 12 preferably can be varied, so that the room carriers 12 do not need to be cut by the installer to precise lengths, if cut at all. The result of this arrangement, as shown in Figure 3 by arrows A, B and C, is that the installer has significant freedom in positioning the carriers. The room carriers 12 can also meet the wall profile 6 at an acute angle in the vertical plane, for instance, if the wall is not vertical and/or if the ceiling is not to be horizontal.

[0030] Further, the carrier end portion 40 is preferably composed of two separable parts, an end bracket 46 and a carrier joining portion 48. The carrier joining portion 48 has a slot 50 along its length which is engaged by a portion of the nut and bolt 42 and allows the variation in the extent to which the end portion 40 projects from the end of the room carrier 12. Preferably the length of the slot 50 is in the region of 50mm, thereby limiting the variation in the extent of projection of the carrier end portion 40 to the region of 50mm.

[0031] The end bracket 46 may be exchangeable with different such end portions, for instance to provide different height dimensions for different types of ceiling panels.

[0032] Figure 4 shows a second embodiment of the invention. This is the same as the first embodiment but in addition has an edge cover 14 inserted into the edge cover support portion 26 of the wall profile 6. All the variations discussed in respect of the first embodiment are similarly applicable to the second one and many other configurations.

[0033] The central portion of Figure 4, that is the inside wall corner, shows the profile 6 in the same situation as that shown in Figure 3. Again the wall bracket 4 is omitted for ease of understanding. In normal use a series of room carriers 12 would also extend across the room from the wall profile 6, similarly to the room carrier shown in Figure 3. A dotted profile of a room carrier 12 is shown.

[0034] The outside wall corner in Figure 4 shows an exploded view of a wall profile 6 and edge cover 14. The edge cover 14 is used to hide and finish off the gap between any ceiling panels and the wall 2. Preferably, the edge cover 14 not only finishes off the gap between the panels and the wall but it can also be used to support the free ends of panels 18 which end at the wall. It is

usually the last part of the system to be mounted, but is shown here without the panels 18 in position. For the arrangement of panels 18 reference will hereinafter be made to Figure 5.

[0035] A spring retainer 60 is received in the edge cover support portion 26 shown in Figures 2a to 2c, in order to press the top of the edge cover 14 against the edge cover retaining portion 28 of the wall profile 6. This retains the edge cover 14 in position.

[0036] Figure 5 shows a cross-section of a wall profile 6 supporting a longitudinal room carrier 12 and ceiling panels 18. For clarity the wall bracket 4 has again been omitted. The wall profile 6 is slightly different from that shown in Figures 2a to 2c. The design of edge cover 14 shown in Figure 5 is one suitable to support the panelling system shown, which uses panels 18 which are of a type and arrangement as described in the European Patent Application published as EP-A2-0,633,365.

[0037] The edge cover 14 shown in Figure 5 has a vertical portion and a horizontal portion. The horizontal portion supports the cut off end of a panel 18 and is itself supported by the horizontal portion received in the edge cover support portion 26 of the wall profile 6. The edge cover 14 is also held in position by the spring retainer 60 slotted into the edge cover support portion 26 between the support portion 26 and the edge cover 14.

[0038] In addition a panel hold-down device 62, shown in Figure 5 as a leaf spring, holds the panel 18 down against the horizontal portion of the edge cover 14.

[0039] The hold-down device 62 can take a number of forms, using resilience, its own mass or a mechanical fixing to hold the edge cover in place. Alternative methods are also possible for attaching the edge cover 14, to the wall profile 6, for instance using a hook to support the edge cover 14. However, preferably, the edge cover is held in a firm position as shown in Figure 5, using something at least equivalent to the spring retainer 60 shown.

[0040] Figure 5 also shows in more detail the end bracket 46. This has an end bracket contact portion 52 which is in contact with the carrier support portion, that is the elongate ledge 22, transferring the weight from the room carrier 12 to the wall profile 6. A hook-under portion 54 which extends slightly beneath the elongate ledge 22 prevents accidental removal of the bracket end portion 46 from its support position, for instance should the room carrier 12 accidentally be lifted upwards.

[0041] The wall profiles 6 of the present invention, as can be seen from the described embodiments, do not need to be carriers for the ceiling panels as well. Their function can be simply to support the room carriers 12 across the room. If used, edge covers can hold the ends of any panels 18. Perimeter profiles 6 are easy to fit, not only because the drill holes used for supporting them do not have to be drilled exactly, but also because, by using mounting brackets 4 the length of time that the profile must be supported from below, by whoever is assem-

bling it, is not as great as when the profile itself must be screwed onto the wall.

[0042] Furthermore, alignment of profiles around inside and outside corners is aided by corner connectors 8 which may simply be pushed or pressed into a suitable channel or groove.

[0043] For unusually shaped rooms or ceiling panels the mounting system of the present invention is also useful, because the room carriers extending into the room area do not need to extend at a fixed angle from the profiles, but can extend at almost any angle in the horizontal and/or vertical planes. Thus, for instance, they can extend diagonally across a room. Similarly, the ceiling panels used need not be square panels in a square grid, but can be lineal, triangular, trapezoidal, rhomboidal or in the form of parallelograms etc.

[0044] Further, whilst the above description assumes the presence of walls, they are not necessary. The mounting means do need some support, but it could be from columns or from above.

[0045] A further embodiment of the invention is shown in Figure 6. Illustrated in Figure 6 is the point where two room carrier members 44 meet end to end in a room where, as frequently happens, one room carrier member 44 is not sufficient to span the whole room. The ends of the carrier members 44 are connected by a splicing bracket 70. This clamps over the tops of the ends of the carrier members 44, as shown in Figure 6, and holds them by means of inwardly directed detents 72 which engage with apertures 56 in the carrier members' sides. The positions of the detents 72 and apertures 56 are such that any panel-holding elements on the carrier members 44, if there are any present, will remain spaced so that the look of the ceiling will not be disrupted. If, however, the panels are simply to be supported on top of the flanges 58 of the carrier members 44 then the designs of the splicing brackets 70 and carrier members 44 do not need to make provision for this.

[0046] As an alternative to detents in the sides of the splicing brackets 72, the brackets could instead be provided with resilient tongues which support the undersides of the tops of the carrier members 44, and preferably clamp them against the tops of the brackets themselves. Other engagement systems are also possible.

[0047] The splicing bracket 70 is provided with a hanger rail 74 which allows it to be supported from a supporting hook 80. As shown in Figure 6, the hanger rail 74 has a longitudinal extent greater than the extent of the supporting hook 80 in the same direction. Thus the hook 80 can support the bracket 70 in any position along the length of the rail 74, and can slide along the rail 74.

[0048] The supporting hook 80 itself is height adjustably mounted on a screw threaded rod 82 which depends from a ceiling bracket 86. The height of the supporting hook 80 on the rod 82 is adjusted using a nut 84.

[0049] The ceiling bracket 86 is attached to the structural ceiling 16 (see Figures 2a-c and Figure 5) using a

fastener, such as a screw 88. The fastener 88 passes through a slot 90 on the ceiling bracket to allow the position of the ceiling bracket 86 to be adjusted. Other combinations of parts between the ceiling bracket 86 and splicing bracket 70 could be used instead.

[0050] The arrows α , β , γ , δ , in Figure 6, show the different directions of movement available to the hanger arrangement and splicing bracket 70. This system too allows for inaccuracies in drilling holes in the structural ceiling 16 for the fasteners 88, or allows the holes to be drilled without requiring knowledge of the exact positions of the room carriers 12 and junctures between two carrier members 44.

[0051] Since intermediate suspensions such as that shown in Figure 6 are required at roughly pre-defined locations and spacings for the best weight distribution of a particular ceiling type, the mounting system of the present invention can be provided with only room carrier members 44 of limited and fixed lengths. These are easier to pack and ship than long ones or carrier members of many different lengths and consequently of easier utility to a non-skilled user. These lengths are preferably an integral multiple of the lengths of the intended or usual ceiling panels, e.g. 1x, 2x, 3x...

[0052] The splicing brackets 70 can be used to support a room carrier 12 at any position along the carrier's length, and do not necessarily need to be used at the ends of carrier members 44. Also, where a splicing bracket 70 does join two carrier members 44 together, it is not necessary that that bracket 70 should be supported from above. Thus the hanging system of the present invention is very versatile. It accommodates variation in quality of the ceiling, ease of access to parts of the ceiling and quick preparation of the ceiling for hanging carriers from it. An extra support hanger can be used where there is an additional load to be suspended, or where it is simply just easier, without requiring a completely different part for the job. On the other hand, in normal use, as it is necessary to join carrier members 44 together, these joins define natural positions for the intermediate suspension hangers, making it easy for a non-skilled user to use the system.

[0053] Various other modifications and variations can be made to the mounting system as described without departing from the scope of the invention as defined in the following claims.

Claims

1. A mounting system for supporting a ceiling, comprising:
 - a perimeter profile (6)
 - at least one mounting bracket (4) for mounting to a fixed support (2) and adapted to receive and mount said perimeter profile (6); and
 - engagement means (10, 20, 24) positioning the

perimeter profile (6) relative to the mounting bracket (4) in at least a first direction;

characterized in that;

said engagement means comprises a clip (10) on said at least one mounting bracket (4), which clip (10) in a first mode prevents motion of said perimeter profile (6) relative to said at least one mounting bracket (4) in a second direction opposed to said first direction while allowing relative movement in said first direction and **in that** said clip (10) in a second mode prevents relative movement of said perimeter profile (6) in said first and second directions.

2. A mounting system according to claim 1, wherein the mode of the clip (10) is changed from the first mode to the second mode by pivoting the clip with respect to said mounting bracket (4).
3. A mounting system according to claim 1 or 2 wherein said engagement means (20, 24) further comprises a toothed portion (20) on one of said at least one mounting bracket (4) and said perimeter profile (6) and a cooperating pawl (30) on the other of said mounting bracket (4) and said perimeter profile (6).
4. A mounting system according to claim 3, wherein the toothed portion (20) comprises ratchet teeth (24) and said pawl (30) is adapted for engaging at least one of the ratchet teeth (24).
5. A mounting system according to any one of claims 3 or 4 wherein the clip (10) further comprises a locking detent (34) allowing the clip (10) to be locked to a portion of the mounting bracket (4) thus preventing relative movement of said perimeter profile in the first and second directions.
6. A mounting system according to claim 3, 4 or 5 wherein said relative motion of said profile (6) in the second direction is prevented by said clip (10) engaging at least one tooth (24) of said toothed portion (20).
7. A mounting system according to any one of claims 3 to 6, wherein said clip comprises a spring clip (10) with the pawl (30) at one end.
8. A mounting system according to any one of claims 3 to 7, wherein said toothed portion (20) is straight.
9. A mounting system according to any one of claims 3 to 8, wherein said toothed portion (20) is provided on said perimeter profile (6).
10. A mounting system according to any one of claims 3 to 9, wherein the one of the toothed portion (20)

and pawl (30)

provided on said perimeter profile (6) extends with constant cross-section along the majority, if not substantially the whole of the length of said profile (6).

11. A mounting system according to any one of the preceding claims, wherein, in use, said relative adjustment of said perimeter profile (6) in said first direction is caused by said perimeter profile (6) being pushed upwards into said mounting means (4).

12. A mounting system according to any one of the preceding claims, wherein said perimeter profile (6) is provided with means for supporting at least one ceiling panel (18).

13. A mounting system according to claim 12 wherein said means for supporting comprises an edge cover (14), in use removably mounted on said profile (6), for supporting at least an edge of at least one ceiling panel (18); and

hold-down means (62) for biasing the at least one edge against said edge cover (14).

14. A mounting system according to any one of the preceding claims, wherein in use said perimeter profile (6) is supported solely from said at least one mounting bracket (4).

15. A mounting system according to claim 14 wherein, in use, said at least one mounting bracket (4) is mounted directly on said support (2).

16. A mounting system according to any one of the preceding claims, further comprising at least one room carrier (12) having an end portion (40) supported, in use, by said perimeter profile (6);

wherein said profile (6) includes room carrier support means (22) for supporting the end portion (40) of said at least one room carrier (12), and the end portion (40) of the at least one room carrier (12) and said support means (22) are arranged so that, in use, the angle between the at least one room carrier (12) and said profile (6) can be varied about an axis perpendicular to the longitudinal axis of the profile (6) and/or an axis parallel to the longitudinal axis of the profile (6).

17. A mounting system according to claim 16 wherein, the or each at least one room carrier (12) comprises a plurality of carrier members (44) of the same length, said length being an integral multiple of the length of the or a ceiling panel (18) intended to be carried by said mounting system.

18. A ceiling support system comprising:

a mounting system according to any one of the preceding claims; and

a splicing bracket (70) for splicing together the ends of two carrier members (44) of a room carrier (12), the splicing bracket (70) comprising: engaging means (72) adapted to engage and support said two ends in alignment with each other; and

bracket support means (74) whereby said splicing bracket (70) and any engaged carrier member (44) or members (44) can be supported from above, said bracket support means (74) comprising a bracket hook or a bracket loop.

19. A ceiling support system according to claim 18 wherein said engaging means comprises two opposing side portions having inwardly directed protrusions (72) for engagement with recesses or holes (56) provided in the sides of said carrier members (44).

20. A ceiling hanging system comprising: a mounting system according to any one of claims 1 to 17 or a ceiling support system according to claim 18 or 19 ; and

a hanger arrangement for supporting a room carrier (12) between the carrier's two ends, the hanger arrangement comprising:

a ceiling bracket (86) for fastening to a ceiling (16) by fastening means (88) ;

a rod (82) depending from said ceiling bracket (86) ; and

carrier supporting means (80) for supporting a room carrier (12) therefrom, adjustably mounted on said rod (82) for relative rotational motion along said rod (82); **characterized in that** said ceiling bracket (86) has a closed-ended slot (90) for insertion therethrough of said fastening means (88), for rotating motion and sliding motion there between; and said rod (82) is screw threaded.

21. A ceiling hanging system according to claim 20 further comprising an adjusting nut (84) on said rod (82), on which said carrier supporting means (80) rests and whereby the axial position of said carrier supporting means (80) on said rod (82) can be adjusted.

22. A ceiling hanging system according to claim 20 or 21 when dependent on claim 18 or 19, wherein the bracket support means comprises a loop (74) and said carrier supporting means (80) comprises a hook for supporting said loop (74).

Patentansprüche

1. Befestigungssystem zum Stützen einer Hängedekke, umfassend:

ein Umfangsprofil (6),

wenigstens einen Befestigungsbügel (4) zum Befestigen an einer festen Stütze (2) und geeignet, um das Umfangsprofil (6) aufzunehmen und zu befestigen; und

ein Eingriffsmittel (10, 20, 24), welches das Umfangsprofil (6) in bezug auf den Befestigungsbügel (4) in wenigstens eine erste Richtung ausrichtet;

dadurch gekennzeichnet, dass

das Eingriffsmittel eine Klemme (10) auf dem wenigstens einen Befestigungsbügel (4) umfasst, wobei die Klemme (10) in einer ersten Betriebsart Bewegung des Umfangsprofils (6) in bezug auf den wenigstens einen Befestigungsbügel (4) in eine zweite Richtung, die der ersten Richtung entgegengesetzt ist, verhindert, während sie relative Bewegung in die erste Richtung erlaubt, und wobei die Klemme (10) in einer zweiten Betriebsart relative Bewegung des Umfangsprofils (6) in die erste und zweite Richtung verhindert.

2. Befestigungssystem nach Anspruch 1, wobei die Betriebsart der Klemme (10) von der ersten Betriebsart auf die zweite Betriebsart durch Drehen der Klemme bezüglich des Befestigungsbügels (4) gewechselt wird.

3. Befestigungssystem nach Anspruch 1 oder 2, wobei das Eingriffsmittel (20, 24) des weiteren einen gezahnten Abschnitt (20) auf einem des wenigstens einen Befestigungsbügels (4) und dem Umfangsprofil (6) und eine zusammenwirkende Sperrklinke (30) auf dem anderen des Befestigungsbügels (4) und dem Umfangsprofil (6) umfasst.

4. Befestigungssystem nach Anspruch 3, wobei der gezahnte Abschnitt (20) Sperrzähne (24) umfasst und die Sperrklinke (30) geeignet ist, um in wenigstens einen der Sperrzähne (24) einzugreifen.

5. Befestigungssystem nach irgendeinem der Ansprüche 3 oder 4, wobei die Klemme (10) des weiteren eine Blockiervorrichtung (34) umfasst, die es der Klemme (10) erlaubt, an einem Abschnitt des Befestigungsbügels (4) blockiert zu werden, und infolgedessen relative Bewegung des Umfangsprofils in die erste und zweite Richtung verhindert.

6. Befestigungssystem nach Anspruch 3, 4 oder 5,

wobei die relative Bewegung des Profils (6) in die zweite Richtung durch die Klemme (10) verhindert wird, indem sie mit wenigstens einem Zahn (24) des gezahnten Abschnitts (20) eingreift.

7. Befestigungssystem nach irgendeinem der Ansprüche 3 bis 6, wobei die Klemme eine federnde Klemme (10) mit der Sperrklinke (30) an einem Ende umfasst.

8. Befestigungssystem nach irgendeinem der Ansprüche 3 bis 7, wobei der gezahnte Abschnitt (20) gerade ist.

9. Befestigungssystem nach irgendeinem der Ansprüche 3 bis 8, wobei der gezahnte Abschnitt (20) auf dem Umfangsprofil (6) vorgesehen ist.

10. Befestigungssystem nach irgendeinem der Ansprüche 3 bis 9, wobei der eine des gezahnten Abschnitts (20) und Sperrklinke (30), vorgesehen auf dem Umfangsprofil (6), sich mit konstantem Querschnitt entlang dem Großteil, wenn nicht im wesentlichen der gesamte Länge des Profils (6) erstreckt.

11. Befestigungssystem nach irgendeinem der vorhergehenden Ansprüche, wobei in Verwendung die relative Einstellung des Umfangsprofils (6) in die erste Richtung dadurch bewirkt wird, dass das Umfangsprofil (6) aufwärts in das Befestigungsmittel (4) gestoßen wird.

12. Befestigungssystem nach irgendeinem der vorhergehenden Ansprüche, wobei das Umfangsprofil (6) mit einem Mittel zum Stützen von wenigstens einer Hängedekentafel (18) versehen ist.

13. Befestigungssystem nach Anspruch 12, wobei das Mittel zum Stützen eine Kantenabdeckung (14), die in Verwendung auf dem Profil (6) abnehmbar befestigt ist, zum Stützen von wenigstens einer Kante von wenigstens einer Hängedekentafel (18) und Niederhaltemittel (62) zum Hinlenken der wenigstens einen Kante gegen die Kantenabdeckung (14) umfasst.

14. Befestigungssystem nach irgendeinem der vorhergehenden Ansprüche, wobei in Verwendung das Umfangsprofil (6) nur von dem wenigstens einen Befestigungsbügel (4) gestützt wird.

15. Befestigungssystem nach Anspruch 14, wobei in Verwendung der wenigstens eine Befestigungsbügel (4) direkt auf der Stütze (2) befestigt ist.

16. Befestigungssystem nach irgendeinem der vorhergehenden Ansprüche, des weiteren umfassend wenigstens einen Raumträger (12), der einen Endab-

schnitt (40) aufweist, der in Verwendung durch das Umfangsprofil (6) gestützt wird;
wobei das Profil (6) Raumträgerstützmittel (22) zum Stützen des Endabschnitts (40) des wenigstens einen Raumträgers (12) umfasst und der Endabschnitt (40) des wenigstens einen Raumträgers (12) und das Stützmittel (22) so angeordnet sind, dass in Verwendung der Winkel zwischen dem wenigstens einen Raumträger (12) und dem Profil (6) um eine Achse im rechten Winkel zur Längsachse des Profils (6) und/oder eine Achse parallel zur Längsachse des Profils (6) geändert werden kann.

17. Befestigungssystem nach Anspruch 16, wobei der oder jeder wenigstens einen Raumträger (12) eine Mehrzahl von Trägerelementen (44) derselben Länge umfasst, und die Länge ein einstückiges Vielfaches der Länge der oder einer Hängedeckenplatte (18) ist, die durch das Befestigungssystem getragen werden soll.

18. Hängedeckenstützsystem, umfassend:

ein Befestigungssystem nach irgendeinem der vorhergehenden Ansprüche; und

eine Verbindungsclammer (70), um die Enden von zwei Trägerelementen (44) eines Raumträgers (12) miteinander zu verbinden, wobei die Verbindungsclammer (70) umfasst:

ein Eingriffsmittel (72), das geeignet ist, um mit den beiden Enden in Ausrichtung miteinander einzugreifen und sie zu stützen; und

Klammerhaltemittel (74), wobei die Verbindungsclammer (70) und jedes in Eingriff gebrachte Trägerelement (44) oder Trägerelemente (44) von oben gehalten werden kann oder können, und das Klammerhaltemittel (74) einen Klammerhaken oder eine Klammer Schlaufe umfasst.

19. Hängedeckenstützsystem nach Anspruch 18, wobei das Eingriffsmittel zwei gegenüberliegende Seitenabschnitte umfasst, die nach innen gerichtete Vorsprünge (72) zum Eingreifen mit Aussparungen oder Löchern (56) aufweisen, die in den Seiten der Trägerelemente (44) vorgesehen sind.

20. Hängedeckenhängesystem, umfassend:

ein Befestigungssystem nach irgendeinem der Ansprüche 1 bis 17 oder ein Hängedeckenstützsystem nach Anspruch 18 oder 19; und

eine Hängeanordnung zum Halten eines Raumträgers (12) zwischen den zwei Trägerelementen,

wobei die Hängeanordnung umfasst:

eine Hängedeckenhalterung (86) zum Anbringen an einer Hängedecke (16) durch Anbringungsmittel (88);

eine Stange (82), die von der Hängedeckenhalterung (16) abhängt; und

Trägerhaltemittel (80) zum Halten eines Trägerelements (12) davon, einstellbar befestigt an der Stange (82) für relative Drehbewegung entlang der Stange (82);

dadurch gekennzeichnet, dass

die Hängedeckenhalterung (86) einen Schlitz mit geschlossenem Ende (90) zum Einfügen dadurch des Anbringungsmittels (88), zur Drehbewegung und zur Gleitbewegung dazwischen aufweist; und

die Stange (82) ein Schraubengewinde hat.

21. Hängedeckenhängesystem nach Anspruch 20, des weiteren umfassend eine Einstellmutter (84) auf der Stange (82), auf welcher das Trägerhaltemittel (80) ruht und wodurch die axiale Position des Trägerhaltemittels (80) auf der Stange (82) eingestellt werden kann.

22. Hängedeckenhängesystem nach Anspruch 20 oder 21, wenn abhängig von Anspruch 18 oder 19, wobei das Klammerhaltemittel eine Schlaufe (74) umfasst und das Trägerhaltemittel (80) einen Haken zum Stützen der Schlaufe (74) umfasst.

Revendications

1. Système de montage pour supporter un plafond, comprenant :

un profil périphérique (6)

au moins une console de montage (4) destinée à être montée sur un support fixe (2) et qui est conçue pour recevoir et monter ledit profil périphérique (6) ; et

un moyen d'enclenchement (10, 20, 24) qui positionne le profil périphérique (6) par rapport à la console de montage (4) dans au moins une première direction ;

caractérisé en ce que :

ledit moyen d'enclenchement comprend une attache (10) sur ladite au moins une console de montage (4), laquelle attache (10) dans un premier

- mode empêche le mouvement dudit profil périphérique (6) par rapport à ladite au moins une console de montage (4) dans une seconde direction opposée à ladite première direction tout en permettant un mouvement relatif dans ladite première direction et **en ce que** ladite attache (10) dans un second mode empêche le déplacement relatif dudit profil périphérique (6) dans lesdites première et seconde directions.
2. Système de montage selon la revendication 1, dans lequel le mode de l'attache (10) est changé pour aller du premier mode au second mode en faisant pivoter l'attache par rapport à ladite console de montage (4).
 3. Système de montage selon la revendication 1 ou 2, dans lequel ledit moyen d'enclenchement (20, 24) comprend en outre une partie dentée (20) sur l'une desdites au moins une console de montage (4) et sur ledit profil périphérique (6) et un cliquet coopérant (30) sur l'autre desdites consoles de montage (4) et sur ledit profil périphérique (6).
 4. Système de montage selon la revendication 3, dans lequel la partie dentée (20) comprend des dents d'encliquetage (24) et ledit cliquet (30) est conçu pour s'enclencher avec au moins l'une des dents d'encliquetage (24).
 5. Système de montage selon l'une quelconques des revendications 3 ou 4, dans lequel l'attache (10) comprend en outre un verrou de blocage (34) qui permet que l'attache (10) soit bloquée sur une partie de la console de montage (4) empêchant de ce fait le déplacement relatif dudit profil périphérique dans la première et dans la seconde directions.
 6. Système de montage selon les revendications 3, 4 ou 5, dans lequel ledit mouvement relatif dudit profil (6) dans la seconde direction est empêché par ladite attache (10) qui s'enclenche avec au moins une dent (24) de ladite partie dentée (20).
 7. Système de montage selon l'une quelconque des revendications 3 à 6, dans lequel ladite attache comprend une attache à ressort (10) avec le cliquet (30) à une extrémité.
 8. Système de montage selon l'une quelconque des revendications 3 à 7, dans lequel ladite partie dentée (20) est droite.
 9. Système de montage selon l'une quelconque des revendications 3 à 8, dans lequel ladite partie dentée (20) est installée sur ledit profil périphérique (6).
 10. Système de montage selon l'une quelconque des revendications 3 à 9, dans lequel soit la partie dentée (20) et soit le cliquet (30) installés sur ledit profil périphérique (6) s'étend, en ayant une coupe transversale constante le long de la plus grande partie, si non sensiblement de la totalité de la longueur dudit profil (6).
 11. Système de montage selon l'une quelconque des revendications précédentes, dans lequel, en exploitation, ledit ajustement relatif dudit profil périphérique (6) dans ladite première direction est provoqué par le fait que ledit profil périphérique (6) est poussé vers le haut dans ledit moyen de montage (4).
 12. Système de montage selon l'une quelconque des revendications précédentes, dans lequel ledit profil périphérique (6) est pourvu d'un moyen de support d'au moins un panneau de plafond (18).
 13. Système de montage selon la revendication 12, dans lequel ledit moyen de support comprend un couvercle de bordure (14), en exploitation, monté sur ledit profil (6) de façon à pouvoir être enlevé, pour supporter au moins un bord d'au moins un panneau de plafond (18) ; et
un moyen de verrouillage (62) pour solliciter le au moins un bord à venir contre ledit couvercle de bord (14).
 14. Système de montage selon l'une quelconque des revendications précédentes, dans lequel, en exploitation, ledit profil périphérique (6) est supporté seulement par ladite au moins une console de montage (4).
 15. Système de montage selon la revendication 14, dans lequel, en exploitation, ladite au moins une console de montage (4) est montée directement sur ledit support (2).
 16. Système de montage selon l'une quelconque des revendications précédentes, comprenant en outre au moins une plate-forme de local (12) dont une partie d'extrémité (40) est supportée, en exploitation, par ledit profil périphérique (6) ;
dans lequel ledit profil (6) comprend un moyen de support de plate-forme de local (22) destiné à supporter la partie d'extrémité (40) de ladite au moins une plate-forme de local ((12), et dans lequel la partie d'extrémité (40) de ladite au moins une plate-forme de local (12) et ledit moyen de support (22) sont agencés de telle façon que, en exploitation, l'angle entre ladite au moins une plate-forme de local (12) et ledit profil (6) peut être modifié autour d'un axe perpendiculaire à l'axe longitudinal du profil (6) et/ou d'un axe parallèle à l'axe longitudinal du profil (6).

17. Système de montage selon la revendication 16, dans lequel, ladite au moins une plate-forme de local (12) ou chacune de celles-ci comprend une pluralité d'éléments porteurs (44) ayant la même longueur, ladite longueur étant un multiple intégral de la longueur du ou d'un panneau de plafond (18) destiné à être porté par ledit système de montage.

18. Système de support de plafond comprenant :

un système de montage selon l'une quelconque des revendications précédentes ; et

une console de raccordement (70) destinée à raccorder ensemble les extrémités des deux éléments porteurs (44) d'une plate-forme de local (12), la console de raccordement (70) comprenant :

un moyen d'enclenchement (72) conçu pour enclencher lesdites deux extrémités en alignement l'une avec l'autre et pour supporter celles-ci ; et

un moyen de support de console (74) grâce auquel ladite console de raccordement (70) et un élément porteur quelconque enclenché (44) ou bien des éléments (44) peuvent être supportés par le dessus, ledit moyen de support de console (74) comprenant un crochet de console ou une boucle de console.

19. Système de support de plafond selon la revendication 18, dans lequel ledit moyen d'enclenchement comprend deux parties latérales opposées possédant des bossages orientés vers l'intérieur (72) pour s'enclencher avec des encoches ou des trous (56) prévus dans les côtés desdits éléments porteurs (44).

20. Système de suspension de plafond comprenant :

un système de montage selon l'une quelconque des revendications 1 à 17 ou bien un système de support de plafond selon la revendication 18 ou 19 ; et

un dispositif de suspension destiné à supporter une plate-forme de local (12) entre les deux extrémités de la plate-forme, le dispositif de suspension comprenant :

une console de plafond (86) destinée à être fixée au plafond (16) grâce à des moyens de fixation (88) ;

une tige (82) selon ladite console de plafond (86) ; et

un moyen de support de plate-forme (80) destiné à supporter une plate-forme de local (12) à partir de celui-ci, qui est monté sur ladite tige (22) de manière à être ajusté pour obtenir un mouvement rotationnel relatif le long de ladite tige (82) ;

caractérisé en ce que

ladite console de plafond (86) possède une fente à extrémité fermée (90) destinée à l'introduction à travers celle-ci dudit moyen de fixation (88), pour obtenir un mouvement rotatif et un mouvement coulissant entre ceux-ci ; et

ladite tige (82) est filetée.

21. Système de suspension de plafond selon la revendication (20), comprenant en outre un écrou de réglage (84) sur ladite tige (82), sur lequel s'appuie le moyen de support de plate-forme (80) et grâce auquel la position axiale dudit moyen de support de plate-forme (80) peut être réglée sur ladite tige (82).

22. Système de suspension de plafond selon la revendication 20 ou 21 qui dépend de la revendication 18 ou 19, dans lequel le moyen de support de console comprend une boucle (74) et dans lequel ledit moyen de support de plate-forme (80) comprend un crochet destiné à supporter ladite boucle (74).

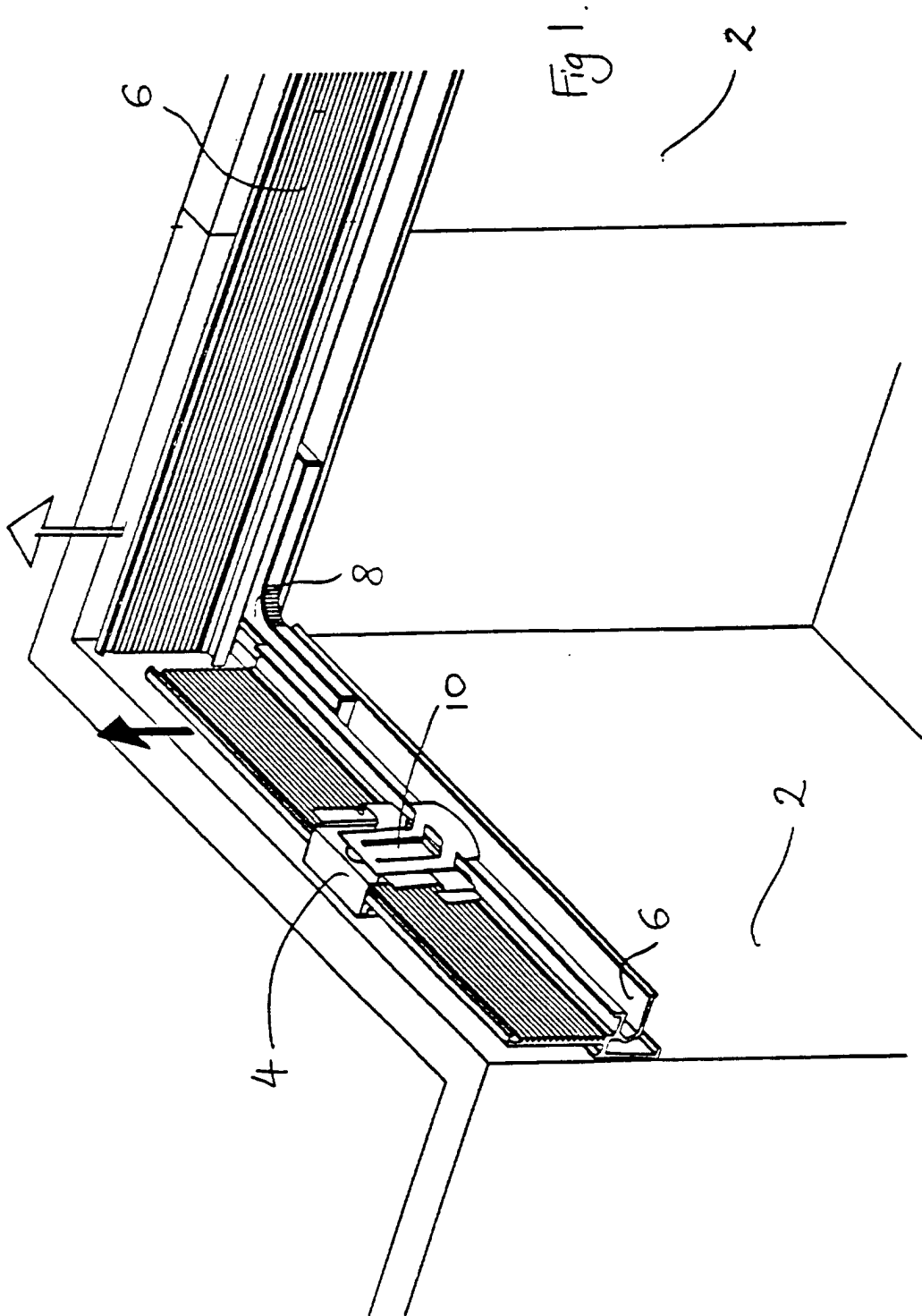

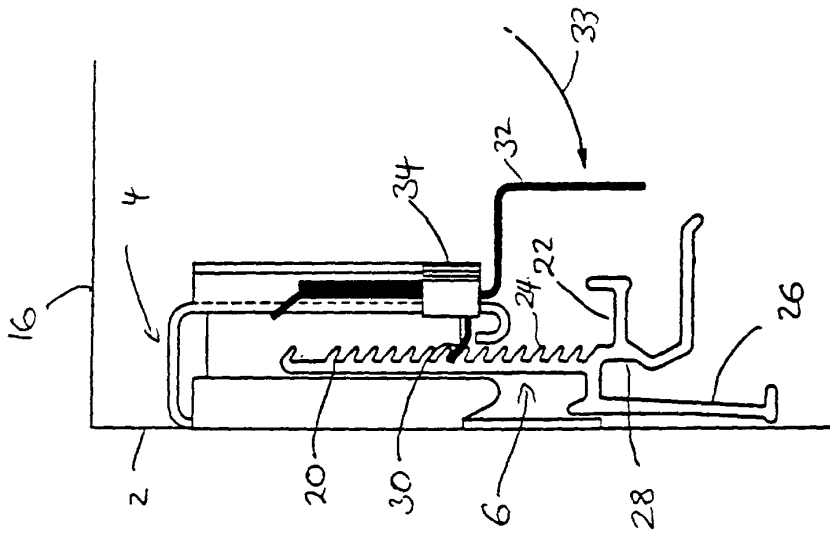

Fig 2c

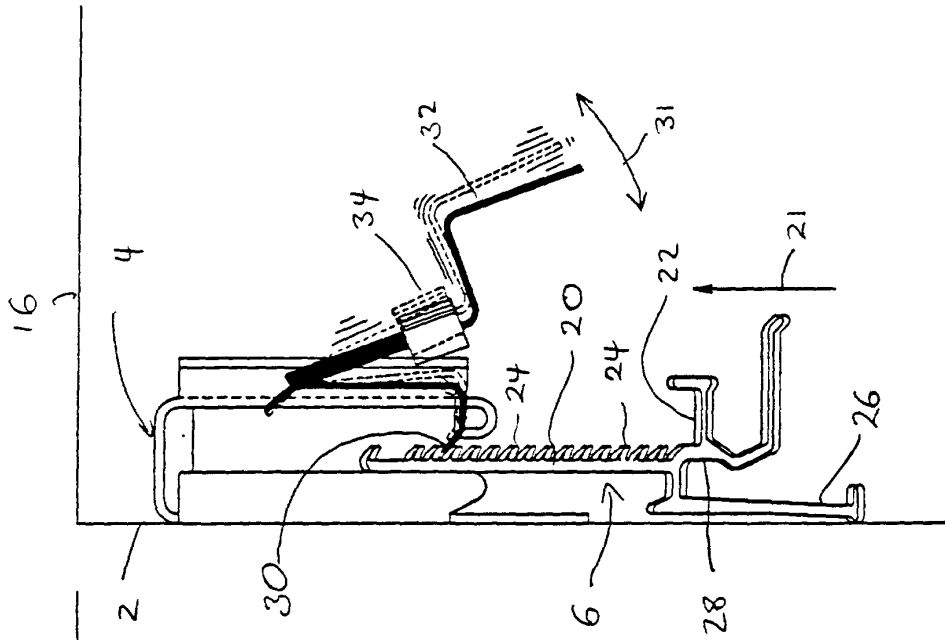

Fig 2b

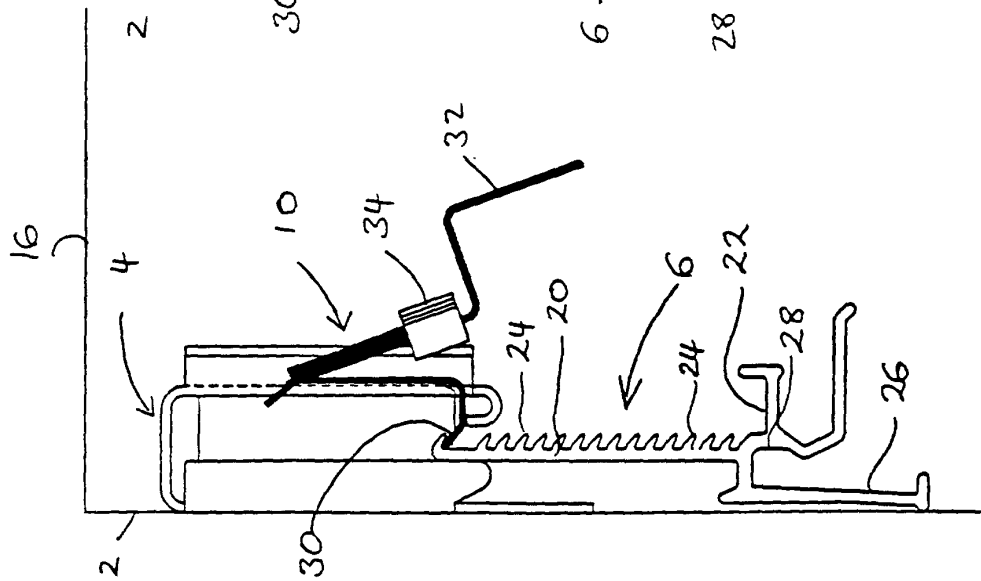
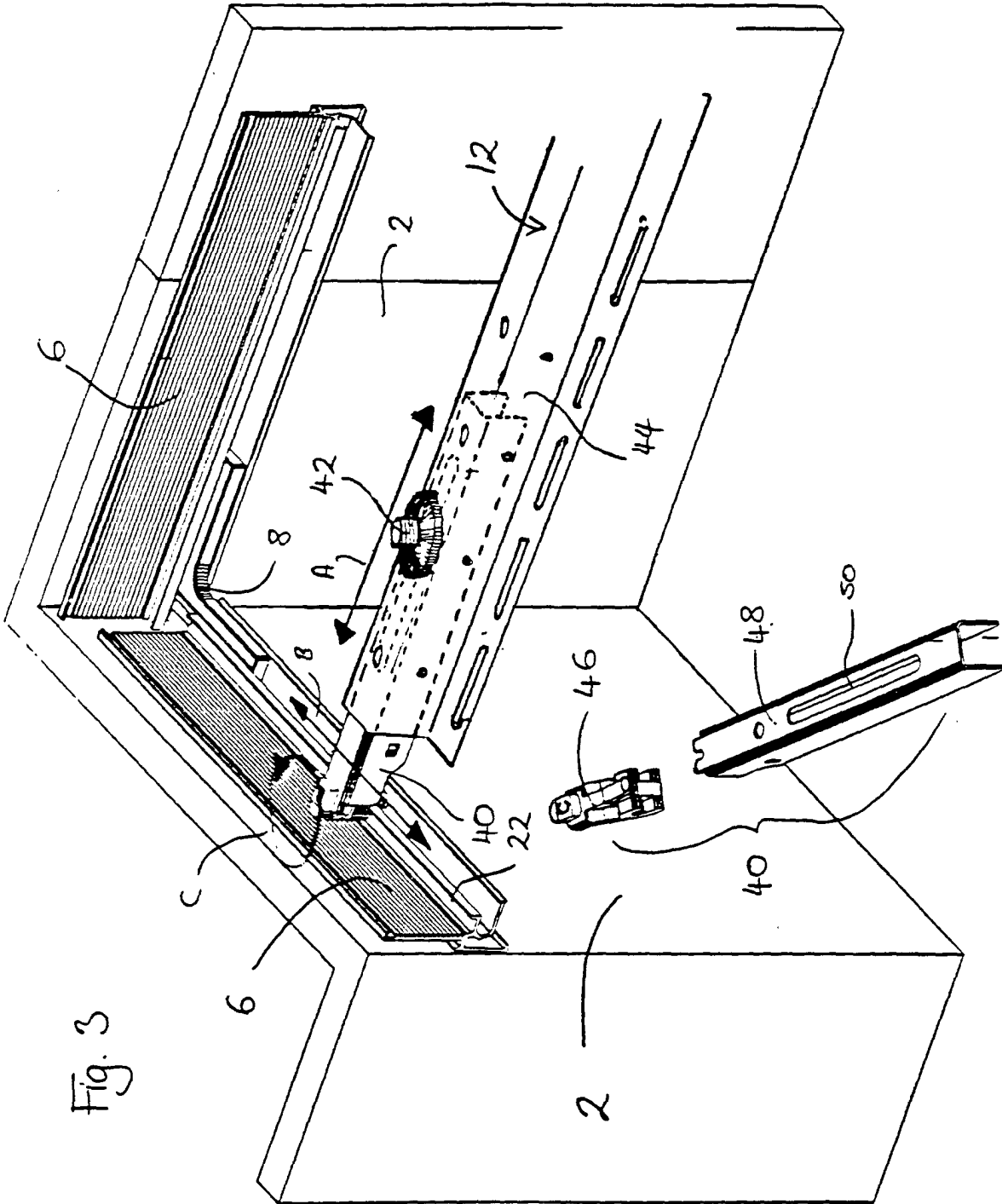

Fig 2a



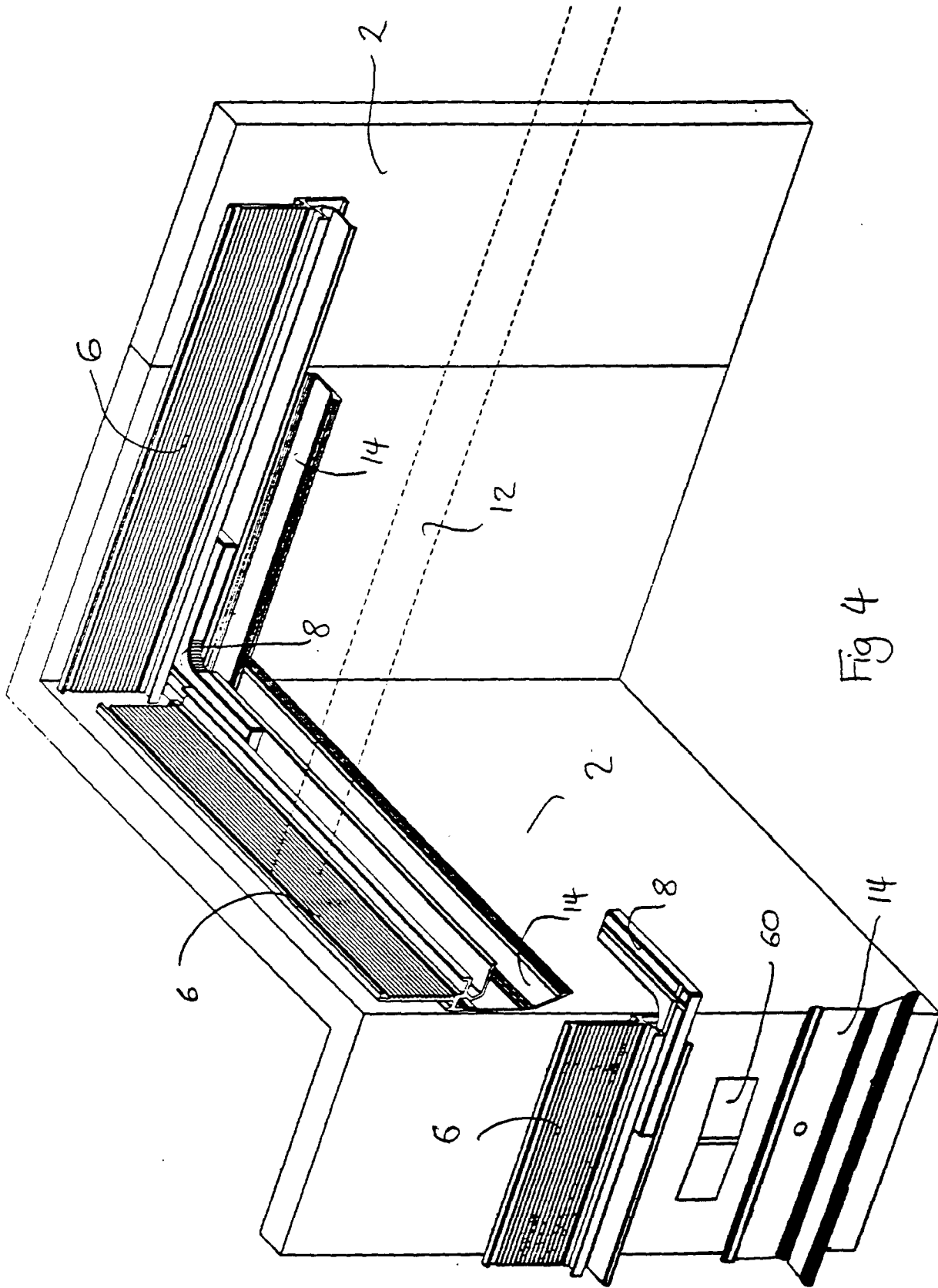

Fig 4

