



(86) Date de dépôt PCT/PCT Filing Date: 2010/12/17
 (87) Date publication PCT/PCT Publication Date: 2011/06/30
 (85) Entrée phase nationale/National Entry: 2012/06/15
 (86) N° demande PCT/PCT Application No.: SE 2010/051409
 (87) N° publication PCT/PCT Publication No.: 2011/078766
 (30) Priorité/Priority: 2009/12/21 (SE0950996-9)

(51) Cl.Int./Int.Cl. *F16B 13/06* (2006.01),
F16B 13/04 (2006.01)
 (71) Demandeur/Applicant:
AKTIEBOLAGET HICET, SE
 (72) Inventeurs/Inventors:
AXELSSON, MAGNUS, SE;
HILLER, MARTIN, SE
 (74) Agent: GOWLING LAFLEUR HENDERSON LLP

(54) Titre : PROCÉDES ET MOYENS POUR FIXER UN ELEMENT DE MONTAGE DANS UN MUR
 (54) Title: PROCEEDING AND MEANS TO FASTEN MOUNTING ELEMENT INTO A WALL

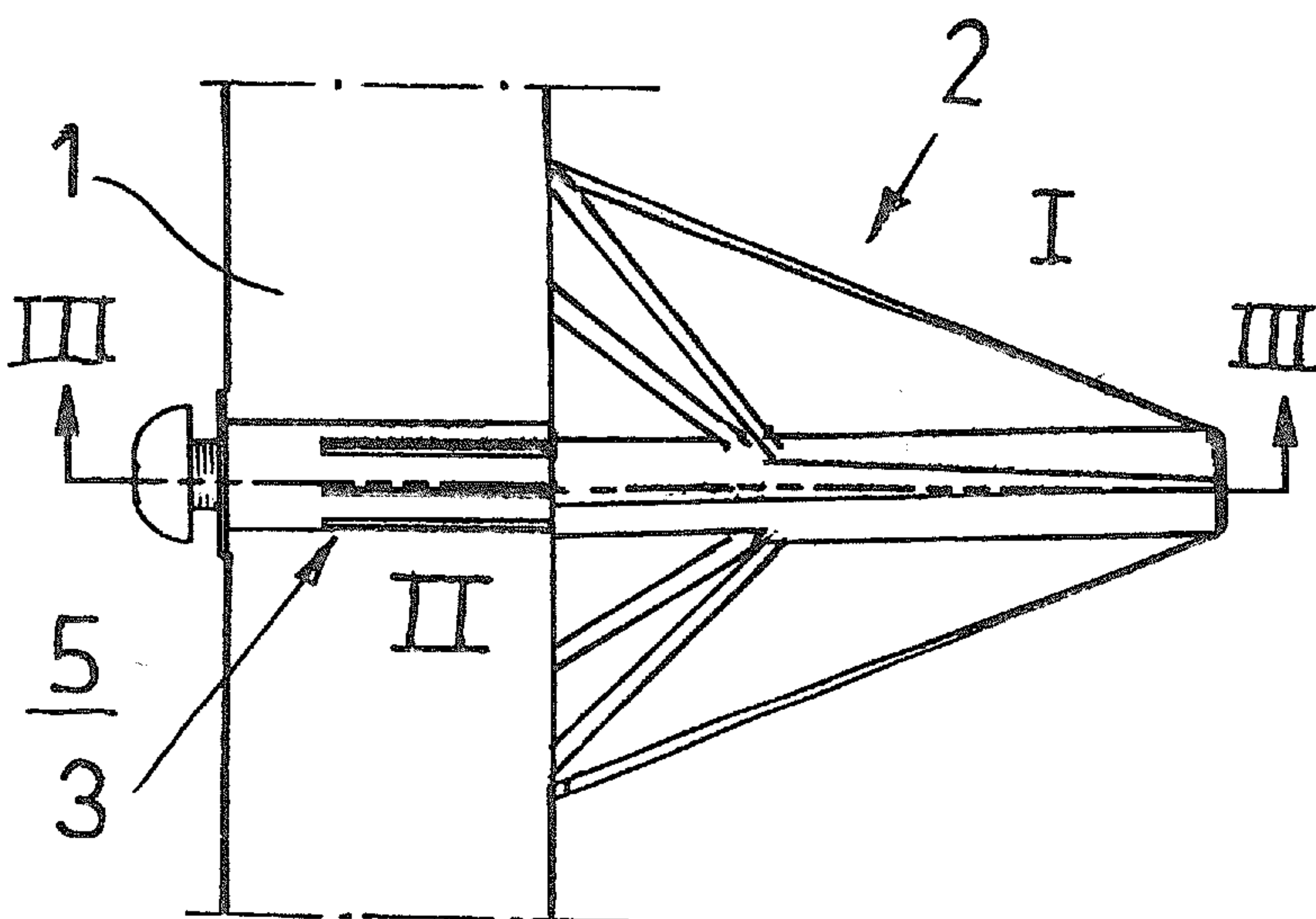

Fig. 2

(57) Abrégé/Abstract:

The present invention relates to both a proceeding and means for, in connection with hole making in a wall (1), for the mounting of items on the moisture-proof walls (1) of a wet area by means of an expandable mounting element (2), providing sealing of the hole. According to the invention, in addition to an expansion (I) of the mounting element (2) behind said wall (1), there is also provided an internal expansion (II) of the mounting element (2) in the receiving hole (3) of the mounting element (2) in question in the wall (1). There is furthermore provided a liquid-proof cover (III) around the entire mounting element (2) in question introduced and expanding in said receiving hole (3).



(12) INTERNATIONAL APPLICATION PUBLISHED UNDER THE PATENT COOPERATION TREATY (PCT)

(19) World Intellectual Property Organization
International Bureau(43) International Publication Date
30 June 2011 (30.06.2011)(10) International Publication Number
WO 2011/078766 A1

(51) International Patent Classification:

F16B 13/06 (2006.01) F16B 13/04 (2006.01)

(21) International Application Number:

PCT/SE2010/051409

(22) International Filing Date:

17 December 2010 (17.12.2010)

(25) Filing Language:

Swedish

(26) Publication Language:

English

(30) Priority Data:

0950996-9 21 December 2009 (21.12.2009) SE

(71) Applicant (for all designated States except US):

FRAMEA INV HB [SE/SE]; Vävarevägen 4E, SE-433 75 Jonsered (SE).

(72) Inventors; and

(75) Inventors/Applicants (for US only): AXELSSON, Magnus [SE/SE]; Krokslättsgratan 8A, SE-431 67 Mölndal (SE). HILLER, Martin [SE/SE]; Vävarevägen 4E, SE-433 75 Jonsered (SE).

(74) Agent: CEGUMARK AB; P.O. Box 53047, SE-400 14 Göteborg (SE).

(81) Designated States (unless otherwise indicated, for every kind of national protection available): AE, AG, AL, AM, AO, AT, AU, AZ, BA, BB, BG, BH, BR, BW, BY, BZ, CA, CH, CL, CN, CO, CR, CU, CZ, DE, DK, DM, DO, DZ, EC, EE, EG, ES, FI, GB, GD, GE, GH, GM, GT, HN, HR, HU, ID, IL, IN, IS, JP, KE, KG, KM, KN, KP, KR, KZ, LA, LC, LK, LR, LS, LT, LU, LY, MA, MD, ME, MG, MK, MN, MW, MX, MY, MZ, NA, NG, NI, NO, NZ, OM, PE, PG, PH, PL, PT, RO, RS, RU, SC, SD, SE, SG, SK, SL, SM, ST, SV, SY, TH, TJ, TM, TN, TR, TT, TZ, UA, UG, US, UZ, VC, VN, ZA, ZM, ZW.

(84) Designated States (unless otherwise indicated, for every kind of regional protection available): ARIPO (BW, GH, GM, KE, LR, LS, MW, MZ, NA, SD, SL, SZ, TZ, UG, ZM, ZW), Eurasian (AM, AZ, BY, KG, KZ, MD, RU, TJ, TM), European (AL, AT, BE, BG, CH, CY, CZ, DE, DK, EE, ES, FI, FR, GB, GR, HR, HU, IE, IS, IT, LT, LU, LV, MC, MK, MT, NL, NO, PL, PT, RO, RS, SE, SI, SK, SM, TR), OAPI (BF, BJ, CF, CG, CI, CM, GA, GN, GQ, GW, ML, MR, NE, SN, TD, TG).

Published:

— with international search report (Art. 21(3))

(54) Title: PROCEEDING AND MEANS TO FASTEN MOUNTING ELEMENT INTO A WALL

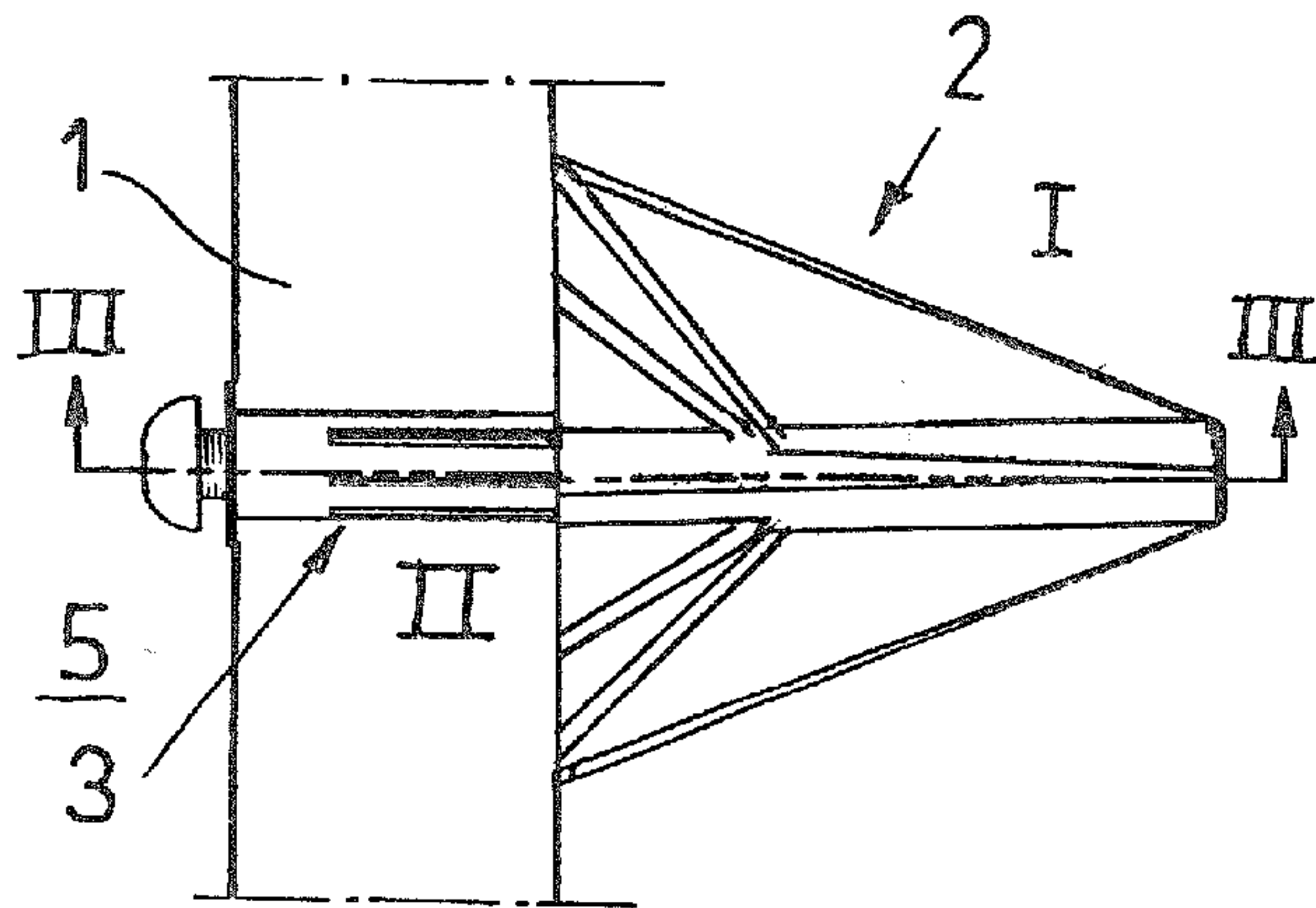

Fig. 2

(57) Abstract: The present invention relates to both a proceeding and means for, in connection with hole making in a wall (1), for the mounting of items on the moisture-proof walls (1) of a wet area by means of an expandable mounting element (2), providing sealing of the hole. According to the invention, in addition to an expansion (I) of the mounting element (2) behind said wall (1), there is also provided an internal expansion (II) of the mounting element (2) in the receiving hole (3) of the mounting element (2) in question in the wall (1). There is furthermore provided a liquid-proof cover (III) around the entire mounting element (2) in question introduced and expanding in said receiving hole (3).

WO 2011/078766 A1

Proceeding and means to fasten mounting element into a wall

The present invention relates to a proceeding
5 for, in connection with hole making in a wall, for the mounting
of items on the moisture-proof walls of a wet area by means of
an expandable mounting element, providing sealing of the hole.

The requirements and desire to moisture-proof
bathrooms and other wet areas have successively augmented dur-
10 ing the years. The insurance industry together with different
professional and industrial organizations work continuously
with disseminating information about how water damage can be
prevented. In spite of this, water damage in bathrooms is still
a significant problem, and only in Sweden, it corresponds to a
15 cost of approx. SEK 39 million per week.

Among private persons, the striving to prevent
damage has increased as the understanding that the damage may
become both expensive and trying has become more apparent. The
attitude among private persons in combination with the interest
20 of the insurance companies make that today there is a market
for new, more reliable and simpler solutions that can provide
for this need.

The reliability in a bathroom relies upon its
waterproof layer. Any mounting that destroys this waterproof
25 layer requires an accurate repair. Instructions for attachment
upon mounting vary depending on what and where to be mounted.
Moreover, the workmanship varies depending on craftsman, occu-
pational group or private person.

The development of a standardized attachment
30 device that is impossible to vary and that is applicable to all
mounting steps would therefore be desirable in order to guaran-
tee that the waterproof layer always becomes correctly restored
independently of the fitter or manufacturer.

Known examples of anchoring means for other attachment items are shown in, among others, DE 3,931,683 A1, which discloses an anchor bolt (12) having an expansion sleeve (10), DE 4,106,507 A1, which discloses a mounting bolt (2) for vehicles and also provided with an expandable sleeve (7), and CA 2,270,570 A, which discloses a bolt (10) having an expandable sleeve (12) situated far out on the threads (18) of the bolt.

All attachments in the wet zone of the wet area should be made in solid structure, e.g., in concrete, in joists, or in a noggling piece. An attachment must not be made solely in a wallboard. This means that when concrete walls are lacking, the position of all fittings has to be predetermined before wet area boards are to be mounted.

At each planned attachment, a postjacent noggling piece is mounted if a joist is lacking. A disadvantage of not being able to make a planned attachment, without a postjacent solid structure, is that the exact position of fittings may be difficult to foresee as well as that a desire to complete with new things may arise sometime later on.

Another disadvantage is that, in connection with the framing of the bathroom, a noggling piece, for instance, may also be missed to be mounted. There is no possibility of putting right a missing noggling piece without needing to dismount a wall in question into its stud work. Attachments using a traditional expander can be made without a solid structure but cannot be applied in wet rooms because of the waterproof layer of the wet room being damaged and thereby losing its sealing capacity.

None of these known solutions provides a liquid-proof fixing. Usually, silicone® is utilized for securing holes against moisture, but not even this gives a reliable sealing, particularly not when screws have been removed from

items that previously have been mounted in and on, respectively, the wall.

Therefore, the main object of the present invention is primarily the development of a system and a wet area expander that are applicable to the walls of wet areas and to mounting steps therefor, and that allow a mounting without a postjacent solid structure without destroying the function of the waterproof layer of the wet room.

Said object is achieved by means of a proceeding according to the invention that essentially is characterized in that, in addition to providing an expansion of the mounting element behind said wall, there is also provided an internal expansion of the mounting element in the receiving hole of the mounting element in question in the wall, as well as there is furthermore provided a liquid-proof cover around the entire mounting element in question introduced and expanding in said receiving hole, and by means of means according to the invention, respectively, that essentially is characterized in that an expansion sleeve has the ability to expand at a distance from each other, as seen along the length extension of the sleeve, that said expansion is arranged to occur externally further in on the sleeve and internally further out on the sleeve, as well as that an expandable, preferably elastic liquid-proof cover surrounds said sleeve from the outer portion thereof.

The invention is also comprised of an additional proceeding that is characterized in that, in addition to providing an expansion of the mounting element behind said wall, there is also provided an internal expansion of the mounting element in the receiving hole of the mounting element in question in the wall, as well as there is furthermore provided a liquid-proofing around the mounting element in question introduced and expanding in said receiving hole.

The invention is also comprised of an additional means for carrying out a proceeding for, in connection with hole making in a wall, for the mounting of items on the moisture-proof walls of a wet area by means of an expandable mounting element, providing sealing of the hole.

A said means is characterized in that an expansion sleeve has the ability to expand at a distance from each other, as seen along the length extension of the sleeve, that said expansion is arranged to occur externally further in on the sleeve and internally further out on the sleeve, as well as that an expandable, preferably elastic liquid-proof cover surrounds said sleeve from the outer portion thereof.

Upon attachment, the expansion sleeve termed as the bathroom expander or the expander plug is applied in a pre-drilled hole and mounting pliers are used in a known way for establishing a correct expansion in the most reliable way. Now, the expansion occurs simultaneously on two parts of the expander plug, on one hand at the back of the hole and the wall, and on the other hand inside the hole. The expansion in the hole is a result of the expander being cut and that there is a cast protrusion inside the front part of the bathroom expander. The mounting tool is placed between the head of the screw and the washer. Pressure is applied in order to get the rear part of the bathroom expander to move toward the mouth of the hole. The effect becomes that also the internal cylinder is pushed forward and presses the cast protrusions against the edges of the pre-drilled hole and the front part expands. The front expansion is regulated by adapting the heights of the cast protrusions in the manufacturing. The bathroom expander has also an expandable metallic or an elastic polymeric covering that follows the expansion and together with suitable compound, for instance Racofix® or silicone®, seals the hole in a liquid-

proof way. It is the front expansion inside the hole that allows the waterproof layer to become restored.

In the following, the invention is described in the form of a number of preferred embodiment examples, reference being made to the drawings, in which

Figs. 1-15 show a first embodiment example, wherein

Fig. 1 shows in perspective and schematically an expanded mounting element,

Fig 2 shows the mounting element as seen from the side,

Fig. 3 shows a section along the line III-III in Fig. 2,

Figs. 4 and 5 show cross-sections of a mounting element and the appurtenant wall,

Fig. 6 shows a section view along the line VI-VI in Fig. 7 of a mounting element,

Fig. 7 shows a side view of a mounting element,

Figs. 8-9 show a side view of a mounting element,

Fig. 10 shows a section view along the line X-X in Fig. 9,

Fig. 11 shows an exploded view of a mounting element according to the invention,

Fig. 12 shows an exploded view of a liquid-proof cover,

Fig. 13 shows in perspective side view the respective sections along the line XIII-XIII of a push rod,

Fig. 14 shows different views of a sheet-metal plate forming an expansion sleeve, and

Fig. 15 shows a said expansion sleeve in perspective, in side view, in end view and in section view, respectively, along the line XV-XV, while

Figs. 16-23 show a second embodiment example of a liquid-proof mounting element, wherein

Fig. 16 shows the mounting element in the expanding state, as seen from different directions,

5 Fig. 17 shows an exploded view of said embodiment example of mounting elements,

Fig. 18 shows an expansion sleeve included in the mounting element in perspective view and side view, respectively,

10 Fig. 19 shows a side view and cross-section, respectively, of the mounting element,

Fig. 20 shows in section view the encircled portion shown in Fig. 19 of a mounting element,

15 Fig. 21 shows different views of a piece of material intended to form an expansion sleeve in question,

Fig. 22 shows in section view and side view, respectively, a said mounting element, and

Fig. 23 shows in perspective and side view, respectively, said mounting element.

20 According to a first embodiment of the present invention, a proceeding according to the present invention refers to, in connection with hole making in a wall 1, for the mounting of items, e.g., sanitary equipment, cupboards, towel rails, mirrors and other necessary items, that are desired to
25 be placed in bathrooms and other suitable wet areas on the moisture-proof walls 1 in question by means of an expandable mounting element 2, the provision of efficient sealing of the hole 3 in question for the mounting element 2 in a reliable and efficient way. Said proceeding involves that, in addition to
30 providing an expansion I of the mounting element 2 behind said wall 1, there is also provided an internal expansion II of the mounting element 2 in the receiving hole 3 of the mounting element 2 in question in the wall 1, as well as there is further-

more provided a liquid-proof III cover 4 around the entire mounting element 2 in question introduced and expanding in said receiving hole 3.

According to the invention, it is furthermore possible to allow an applied expandable compound (not shown) surround the liquid-proof III cover 4 and seal the hole 3.

A said indicated proceeding is both simple and efficient in terms of structure as well as use.

Means for carrying out an indicated proceeding for, in connection with hole making in a wall 1, for the mounting of items on the moisture-proof walls 1 of a wet area 5 by means of an expandable mounting element 2, providing sealing of the hole 3 according to the above mentioned involves that an expansion sleeve 6 has the ability to expand I; II at a mutual distance A from each other, as seen along the length extension 7 of the sleeve. Said expansion I; II is arranged to occur externally on the sleeve further in on the sleeve 6 as seen in the direction from the rear end 6A of the sleeve and internally further out on the sleeve 6, as well as that a metallic expandable or an elastic liquid-proof cover 4 surrounds said sleeve 6 and a pressure part 8 connectable thereto in the direction from the outer rear portion 6A thereof and around the circumference of the entire sleeve as well as in a liquid-proof way around the front inner face portion 6B thereof and around the face portion of the pressure part 8.

Preferably, said cover 4 consists of latex rubber, plastic or another similar expandable and air- and liquid-proof material. In the case of a metallic expandable cover 4, said metal is formed of aluminium that has good liquid-proofing capacity.

Internally in the expansion sleeve 6, a sleeve-shaped said pressure part 8 closed in the inner end 8A is receivable and that is provided with internal threads 9. Said

pressure part 8 is attached to the expansion sleeve 6, for instance by welding, agglutination, etc., at the area of the shoulder 32 of the pressure part and the end 33 of the sleeve 6 when the parts 6, 8 are assembled. On said sleeve 6, separated
5 groups 10, 11 having expandable parts 10A, 10B ...; 11A, 11B... are situated, and preferably said expandable parts 10A...; 11A... are formed of perforations in the cover of the sleeve 6.

Internally in the sleeve 6, at the area of the rear group 11 of perforations, a thickened portion 12 of the
10 sleeve 6 is arranged, preferably in the form of parallel pads 12A, 12B, 12C,... 12n situated at a mutual distance from each other, as seen along the circumference of the sleeve.

Said pressure part 8 has, at one end 8B thereof, a rear stop part 13 at an area 14 of a thinner portion
15 of the pressure part 8, and which stop part 13 is arranged to co-operate with the front end portion 6B of the sleeve for the provision of expansion of front expandable parts as well as rear expandable parts when distancing the screw 15 received therein and the sleeve 6 in its longitudinal direction by means
20 of mounting pliers in a known way.

Around the circumference of said pressure part 8, a number of chamfers 30 are arranged, extending in the length extension 31 of the pressure part 8. Said chamfers 30 are arranged to strengthen the expander 6 so that it is not
25 urged to be turned without expansion occurring in the desired direction and in the correct way.

Said elastic liquid-proof cover 4, which is arranged to surround both the sleeve 6 and the pressure part 8, may be formed of a sleeve-shaped rubber or plastic bag, and
30 this is arranged to be threaded onto the sleeve 6 and the pressure part 8 before the same are introduced into the drill hole 3 in the direction from the wet area 5 in question as a joint unit. The cover may alternatively be formed of a liquid-proof

metallic cover that is expandable. For instance, the cover may consist of aluminium that may be in the form of a corrugated liquid-proof cover that can expand into the desired shape.

Internally in the expansion sleeve 6, a said
5 screw 15 is arranged to be screwed in and received therein to the major part for carrying the intended attachment item. A reaction washer 16 is threaded on said screw 15 inside the screw head 17, and between which mounting pliers are arranged to act upon tightening and expansion of the front expandable portion
10 of the expander by means of the mounting pliers in a known way after the screwing-in of screws 15 into the mounting element, in threads 9 at the rear end 8B of the pressure part 8, which is introduced with the tapering part 14 thereof into the internal reception space 18 of the mounting element 2.

15 The part of the mounting element 2 manufactured and formed of metal as an expansion sleeve 6 is preferably made from a flat sheet of plastic or sheet-metal plate 19 that is provided with a number of longitudinal parallel through perforations 11 as well as internal pads 12A, 12B in the wall of the
20 convolutable sheet 19. Special threads are not needed now on said sleeve 6, but the threads 9 are instead arranged in the pressure part 8, which is unturnably attached to the sleeve 6.

The embodiment of the invention that is shown as a second example in the drawings in Figs. 16-23 differs from
25 the embodiment described above of proceeding and means for attaching mounting elements in a wall foremost by the expansion as well as by the liquid-proof cover of the mounting element.

Accordingly, a proceeding for, in connection with hole making in a wall 101, for the mounting of items on
30 the moisture-proof walls 101 of a wet area by means of an expandable mounting element 102, providing sealing of the hole 103 is characterized in that, in addition to providing an expansion CI of the mounting element 102 behind said wall 101,

there is also provided an internal expansion CII of the mounting element 102 in the receiving hole 103 of the mounting element 102 in question in the wall 101, as well as there is furthermore provided a liquid-proofing CIII around the mounting element 102 in question introduced and expanding in said receiving hole.

Said internal expansion CII as well as the liquid-proofing CIII in the receiving hole 103 are provided by means of a common element in the form of an elastic cover 150.

10 For further increasing the reliability against moisture damage, it is furthermore possible to allow applying an expandable compound to surround the liquid-proof CIII cover 150 and seal the hole 103.

Means for carrying out an additional proceeding, according to what has been mentioned above, for, in connection with hole making in a wall 101, for the mounting of items on the moisture-proof walls 101 of a wet area 105 by means of an expandable mounting element 102, providing sealing of the hole 103 comprises an expansion sleeve 106 that has the ability to expand CI, CII at a distance CA from each other, as seen along the length extension 107 of the sleeve. Said expansion CI; CII is arranged to occur externally further in on the sleeve 106 inside the wall 103 and internally further out on the sleeve 106 within the wall 103. An expandable, preferably elastic liquid-proof cover 104 is received on the outer portion 106A of said sleeve 106 and the function of which will be described below.

Internally in the expansion sleeve 106, at least a portion of a sleeve-shaped pressure part 108 closed 151 in one end and having internal threads 109 is receivable. Separated groups 110, 111 having expandable parts 110; 104 are situated on said sleeve 106 at a mutual distance CA from each other, as seen along the length extension 107 of the sleeve

106, said front expandable parts 110 being formed of perforations of the cover of the sleeve 106.

Said pressure part 108 has a stop part 113 that is arranged to co-operate with the front end portion 140 of the sleeve for the provision of expansion of front expandable parts as well as rear expandable parts when distancing the screw received therein and the sleeve in its longitudinal direction by means of mounting pliers. Said expandable, sleeve-shaped elastic liquid-proof cover 104, which is double-walled 153, 154 and sealed 155 at one end 104A thereof, is arranged to surround part of the sleeve 106, both internally in and externally of the same, and is formed of a sleeve-shaped cover 104 that consists of rubber, plastic, aluminium or another elastic and liquid-proof material.

A screw 115 screwable internally into the expansion sleeve 106 carries a reaction washer 116 inside the screw head 117 thereof.

Said expansion sleeve 106 is preferably made from a sheet 119 of sheet-metal plate or plastic having longitudinal parallel through perforations 110, 111 in the convolvable sheet 119, or may be produced in another suitable way.

The circumference of said pressure part 8 is identical to the circumference of the end co-operatable portion 156 of the expansion sleeve 106.

The nature and function of the invention should have been clear from what has been described above and shown in the drawings, and the invention is naturally not limited to the embodiments described above and shown in the accompanying drawings. Modifications are feasible, particularly as for the nature of the different parts, or by using an equivalent technique, without departing from the protection area of the invention, such as it is defined in the claims.

CLAIMS

5 1. Proceeding for, in connection with hole making
in a wall (1), for the mounting of items on the moisture-proof
walls (1) of a wet area by means of an expandable mounting ele-
ment (2), providing sealing of the hole, **characterized in** that,
in addition to providing an expansion (I) of the mounting ele-
10 ment (2) behind said wall (1), there is also provided an inter-
nal expansion (II) of the mounting element (2) in the receiving
hole (3) of the mounting element (2) in question in the wall
(1), as well as there is furthermore provided a liquid-proof
cover (III) around the entire mounting element (2) in question
15 introduced and expanding in said receiving hole (3).

2. Proceeding according to claim 1, **characterized**
in that an applied expandable compound is allowed to surround
the liquid-proof (III) cover (4) and seal the hole (3).

20

3. Means for carrying out a proceeding for, in
connection with hole making in a wall (1), for the mounting of
items on the moisture-proof walls (1) of a wet area (5) by
means of an expandable mounting element (2), providing sealing
25 of the hole (3) according to any one of the preceding claims,
characterized in that an expansion sleeve (6) has the ability
to expand (I, II) at a distance (A) from each other, as seen
along the length extension (7) of the sleeve, that said expan-
sion (I; II) is arranged to occur externally further in on the
30 sleeve (6) and internally further out on the sleeve (6), as
well as that an expandable, preferably elastic liquid-proof
cover (4) surrounds said sleeve (6) from the outer portion (6A)
thereof.

4. Means according to claim 3, **characterized in** that, internally in the expansion sleeve (6), at least a portion of a sleeve-shaped pressure part (8) having internal threads (9) is receivable, separated groups (10, 11) having expandable parts (10A, 10B...; 11A, 11B...) being situated on said sleeve (6) at a mutual distance (A) from each other, as seen along the length extension (7) of the sleeve (6).

10 5. Means according to claim 4, **characterized in** that said expandable parts (10A, 10B...; 11A, 11B...) are formed of perforations of the cover of the sleeve (6).

15 6. Means according to claim 5, **characterized in** that, internally in the sleeve (6), at the area of the rear group (11) of perforations, a thickened portion (12) of the sleeve (6) is arranged, preferably in the form of parallel pads (12A, 12B, 12C ... 12n) situated at a mutual distance from each other.

20 7. Means according to any one of claims 4-6, **characterized in** that said pressure part (8) has a stop part (13) that is arranged to co-operate with the front end portion of the sleeve for the provision of expansion of front expandable parts as well as rear expandable parts when distancing the screw received therein and the sleeve in its longitudinal direction by means of mounting pliers.

30 8. Means according to any one of claims 3-7, **characterized in** that said expandable, preferably elastic liquid-proof cover (4), which is arranged to surround the sleeve (6), is formed of a sleeve-shaped cover that consists of rubber, plastic or aluminium.

9. Means according to any one of claims 3-8, **characterized in** that a screw (15) screwable internally into the expansion sleeve (6) carries a reaction washer (16) inside the screw head (17) thereof.

10. Means according to any one of claims 3-9, **characterized in** that the expansion sleeve (6) is made from a sheet (19) of sheet-metal plate or plastic having longitudinal parallel through perforations (10, 11) and internal pads (12A, 12B) in the convolvable sheet (19).

11. Means according to any one of claims 4-10, **characterized in** that, around the circumference of said pressure part (8), a number of chamfers (30) are arranged, extending in the length extension (31) of the pressure part internally in the expansion sleeve (6).

12. Proceeding for, in connection with hole making in a wall (101), for the mounting of items on the moisture-proof walls of a wet area by means of an expandable mounting element (102), providing sealing of the hole (103), **characterized in** that, in addition to providing an expansion (CI) of the mounting element (102) behind said wall, there is also provided an internal expansion (CII) of the mounting element (102) in the receiving hole (103) of the mounting element (102) in question in the wall (101), as well as there is furthermore provided a liquid-proofing (CIII) around the mounting element (102) in question introduced and expanding in said receiving hole (103).

13. Proceeding according to claim 12, **characterized in** that said internal expansion (CII) as well as the liquid-proofing (CIII) in the receiving hole (103) are provided by means of a common element in the form of an elastic cover
5 (150).

14. Proceeding according to claim 12, **characterized in** that an applied expandable compound is allowed to surround the liquid-proof (CIII) cover (150) and seal the hole (103).
10

15. Means for carrying out a proceeding for, in connection with hole making in a wall (101), for the mounting of items on the moisture-proof walls (101) of a wet area (105) by means of an expandable mounting element (102), providing
15 sealing of the hole (103) according to any one of the preceding claims 12-14, **characterized in** that an expansion sleeve (106) has the ability to expand (CI, CII) at a distance (CA) from each other, as seen along the length extension (107) of the sleeve, that said expansion (CI; CII) is arranged to occur ex-
20 ternally further in on the sleeve (106) inside the wall (103) and internally further out on the sleeve (106) in the wall (103), as well as by an expandable, preferably elastic liquid-proof cover (104) on the outer portion (106A) of said sleeve (106).
25

16. Means according to claim 15, **characterized in** that, internally in the expansion sleeve (106), at least a portion of a sleeve-shaped pressure part (108) closed (151) in one end and having internal threads (109) is receivable, separated
30 groups (110, 111) having expandable parts (110; 104) being situated on said sleeve (106) at a mutual distance (CA) from each other, as seen along the length extension (107) of the sleeve (106).

17. Means according to claim 16, **characterized in** that said front expandable parts (110) are formed of perforations of the cover of the sleeve (106).

5

18. Means according to any one of claims 16-17, **characterized in** that said pressure part (108) has a stop part (113) that is arranged to co-operate with the front end portion (140) of the sleeve for the provision of expansion of front expandable parts (CI) as well as rear expandable parts when distancing the screw received therein and the sleeve in its longitudinal direction by means of mounting pliers.

19. Means according to any one of claims 15-18, **characterized in** that said expandable, sleeve-shaped elastic liquid-proof cover (104), which is double-walled (153, 154) and sealed (155) at one end (104A) thereof, is arranged to surround part of the sleeve (106), both internally in and externally of the same, and is formed of a sleeve-shaped cover (104) that consists of rubber, plastic, aluminium or another elastic material.

20. Means according to any one of claims 15-19, **characterized in** that a screw (115) screwable internally into the expansion sleeve (106) carries a reaction washer (116) inside the screw head (117) thereof.

21. Means according to any one of claims 15-20, **characterized in** that the expansion sleeve (106) is made from a sheet (119) of sheet-metal plate or plastic having longitudinal parallel through perforations (110, 111) in the convolutable sheet (119).

30

22. Means according to any one of claims 16-18, **characterized in** that the circumference of said pressure part (108) is identical to the circumference of the end co-operatable portion (156) of the expansion sleeve (106).

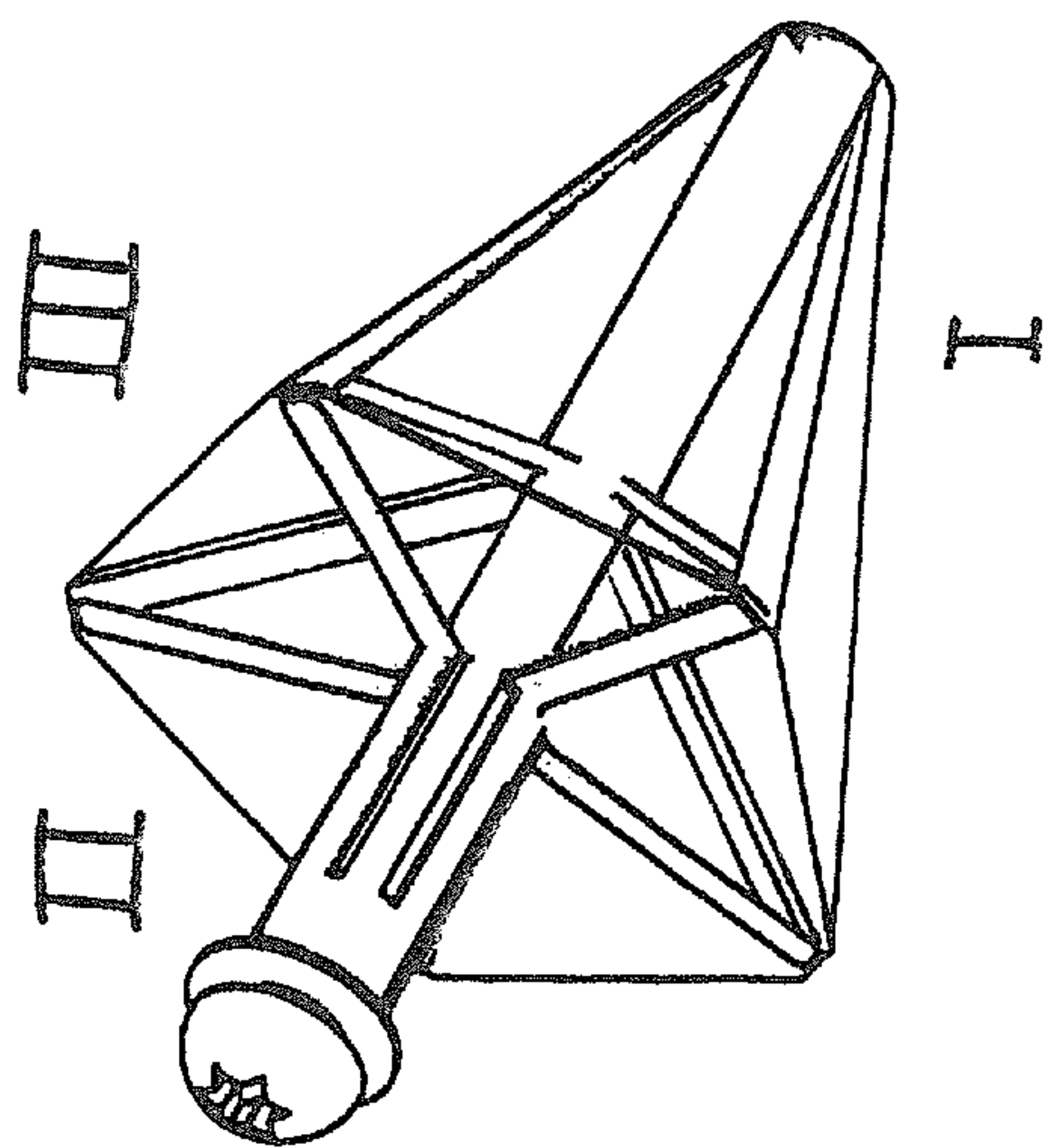

Fig. 1

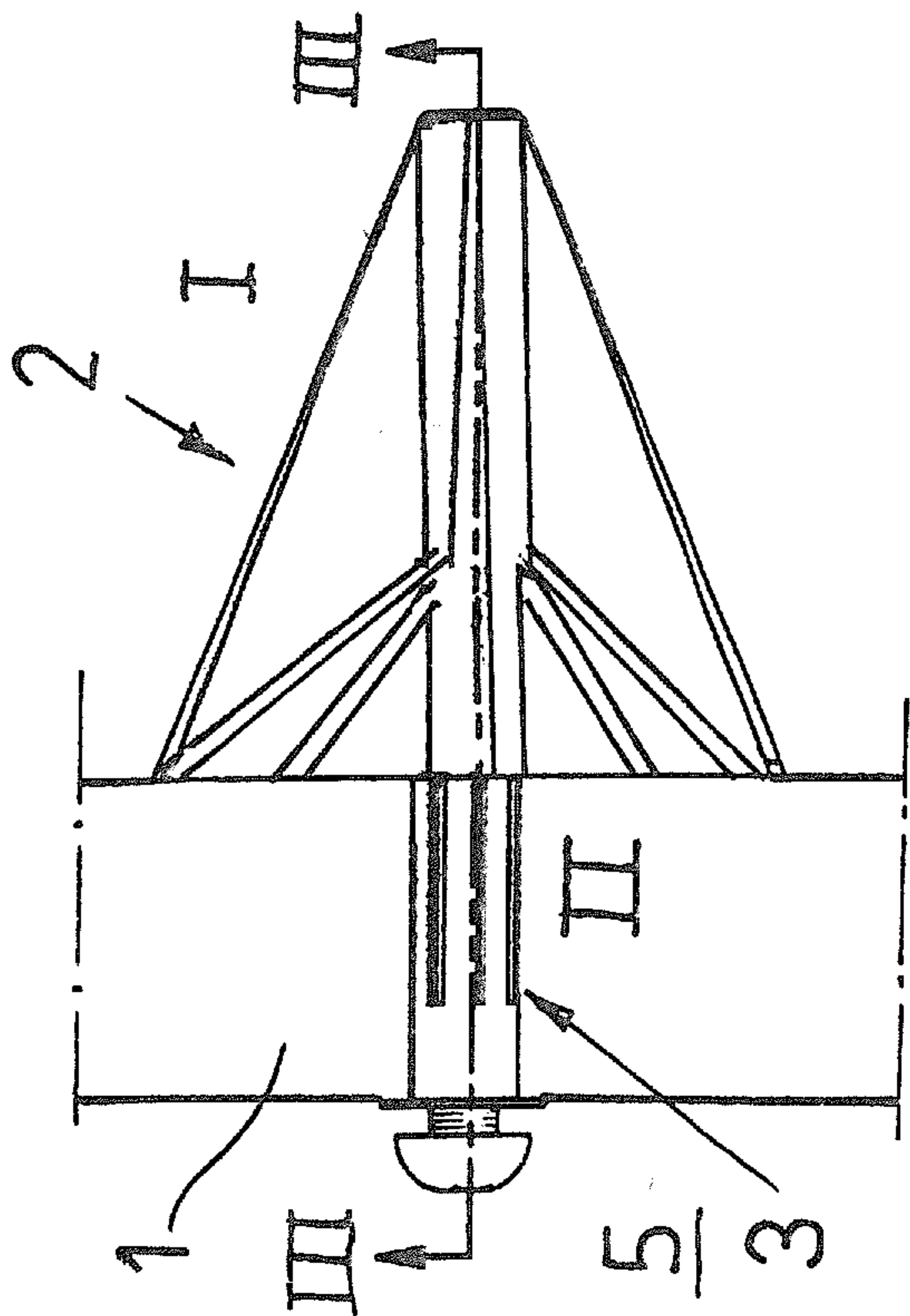

Fig. 2

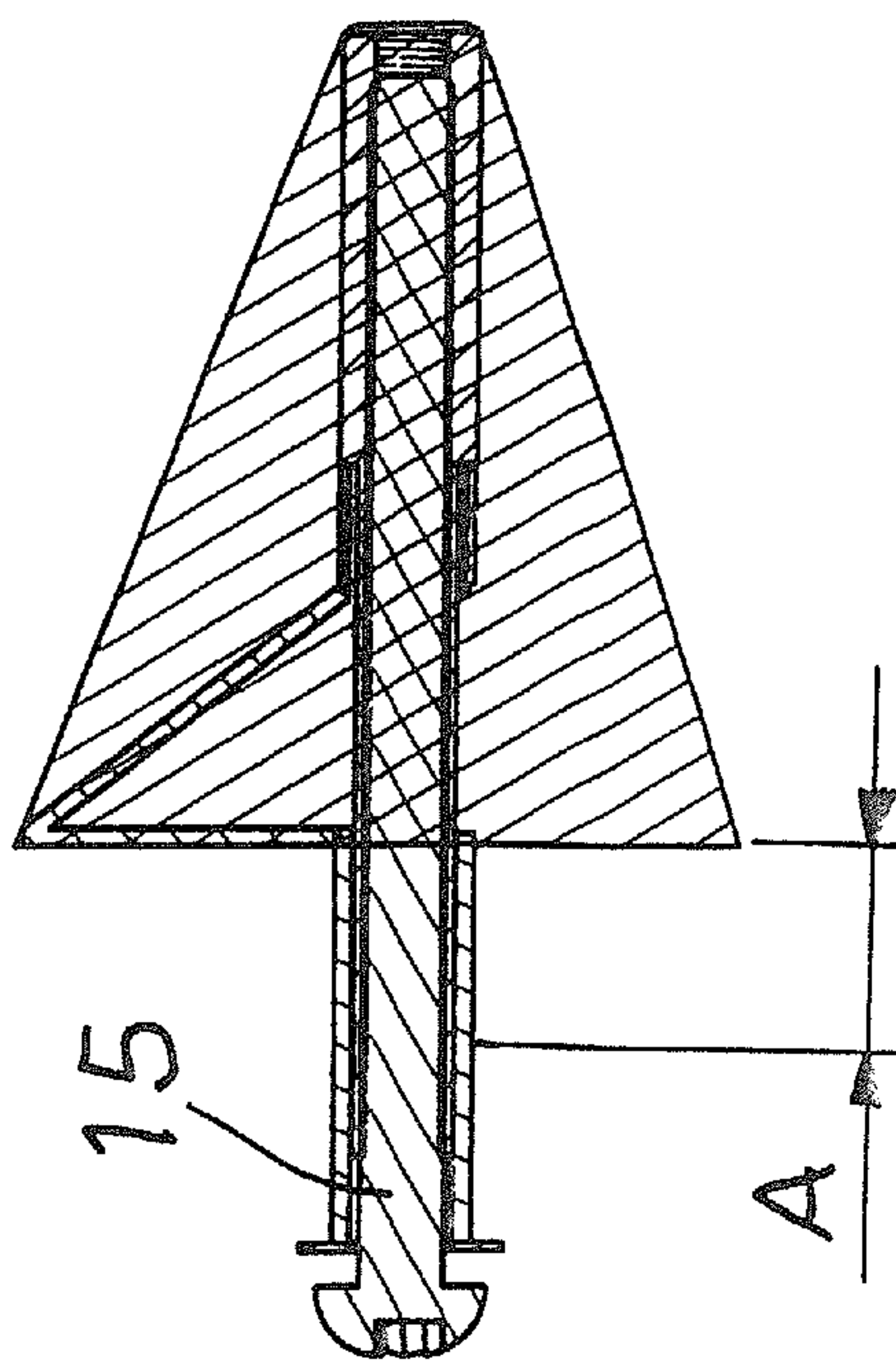

Fig. 3

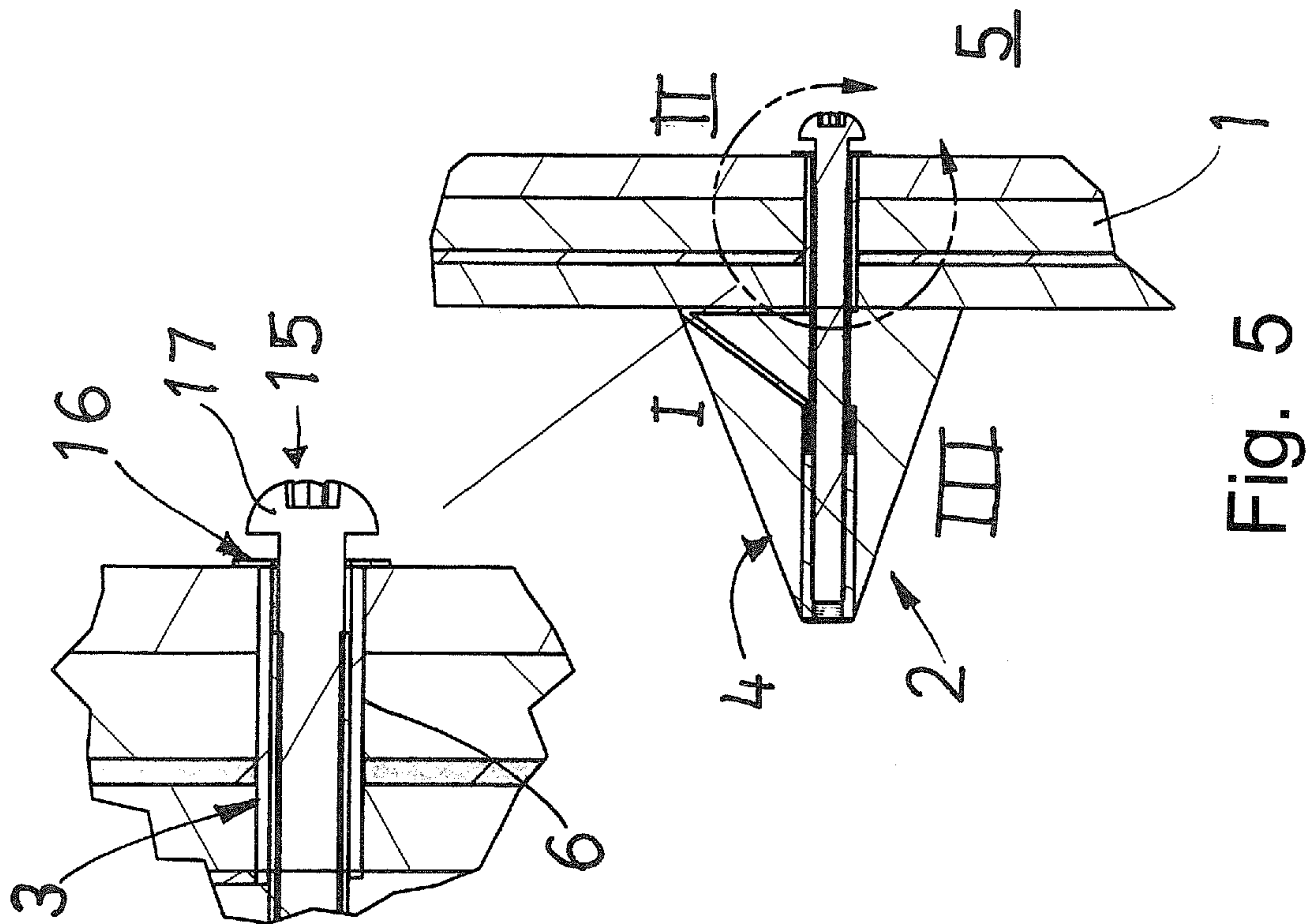

Fig. 5

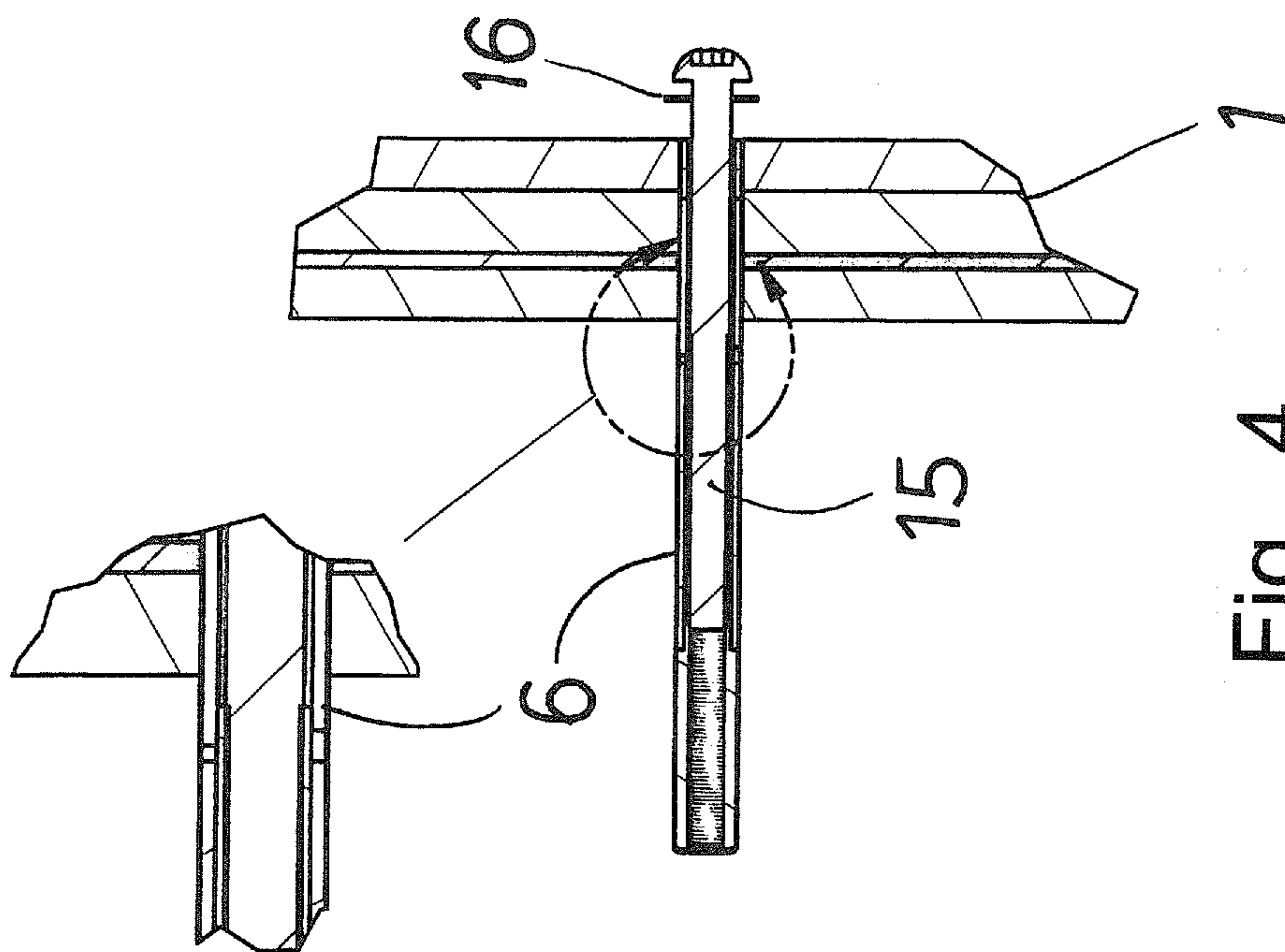

Fig. 4

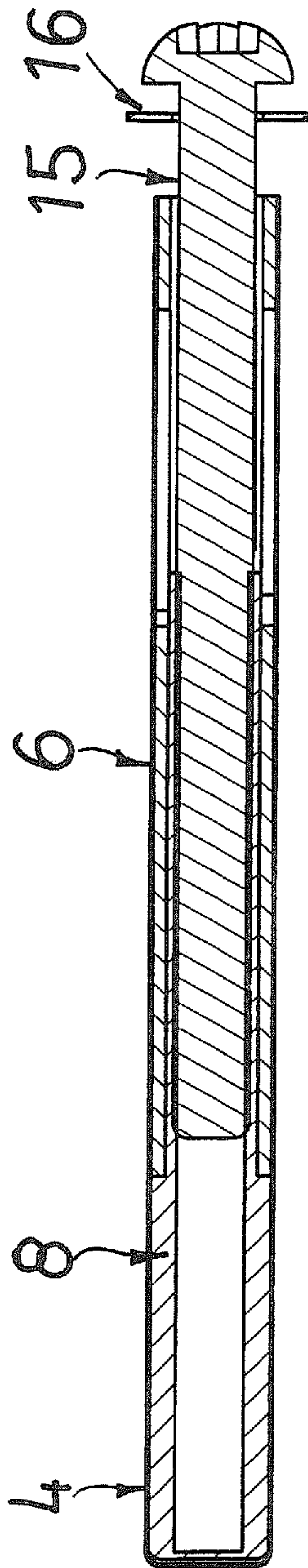

Fig. 6

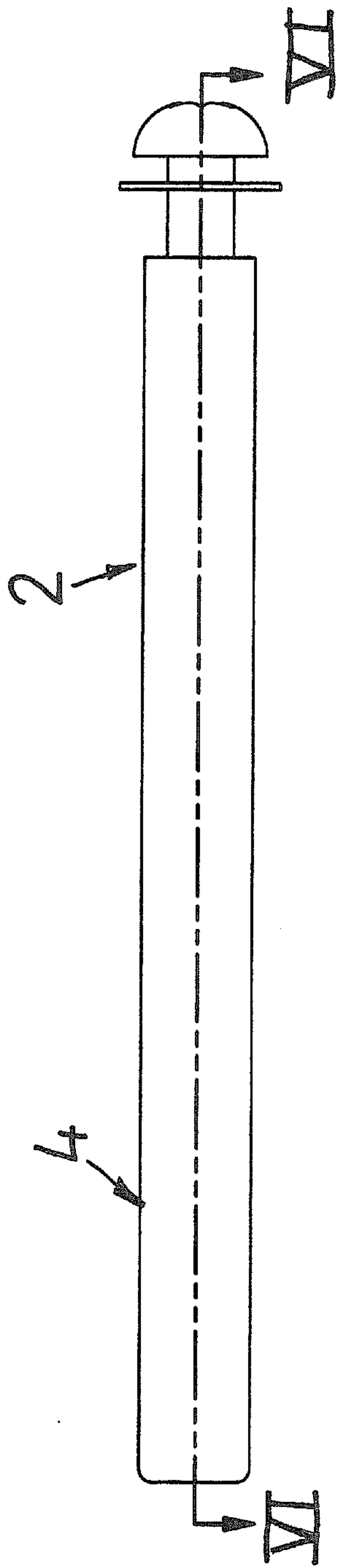

Fig. 7

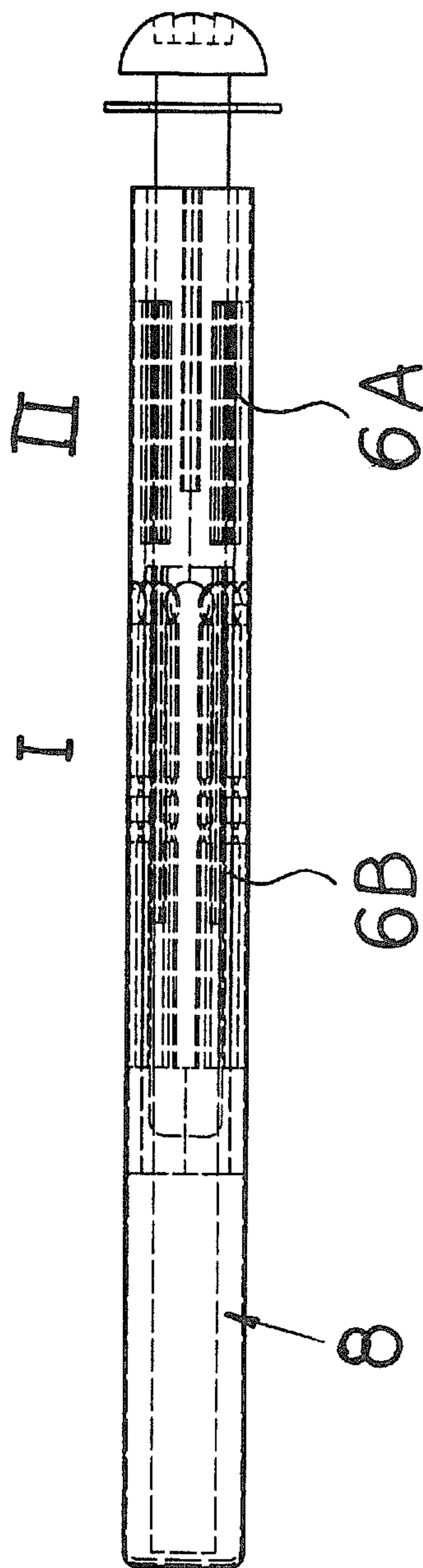
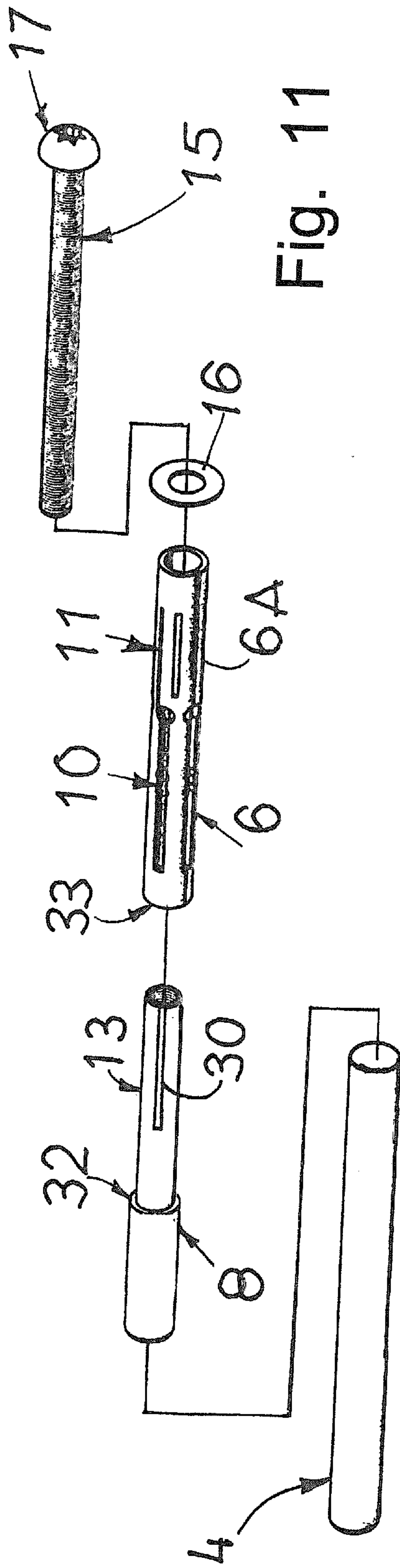
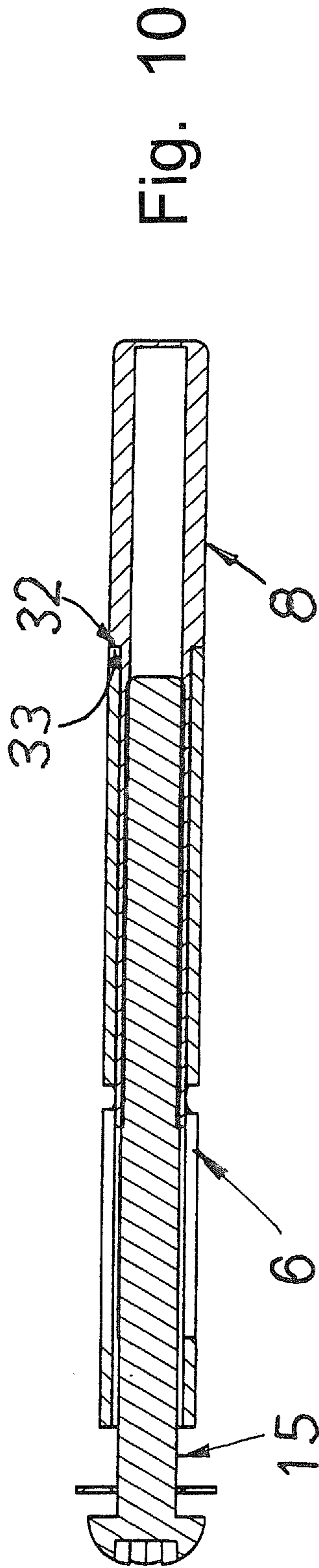
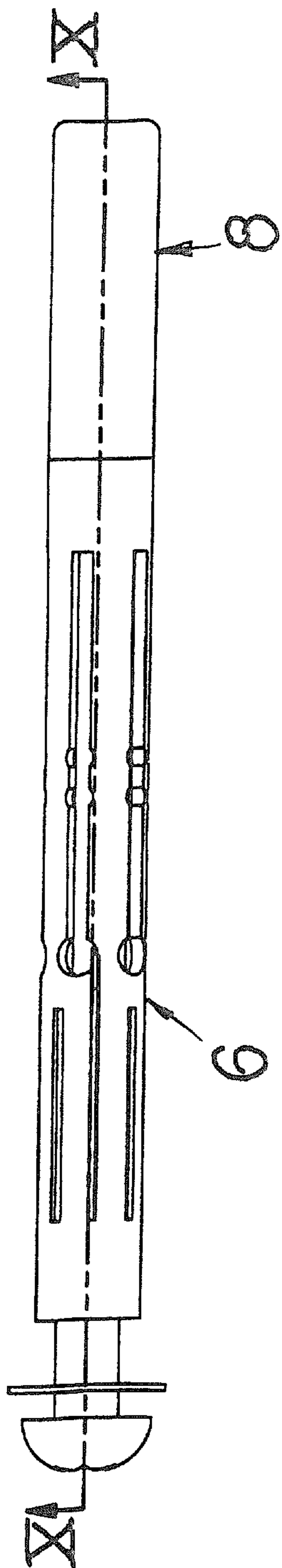
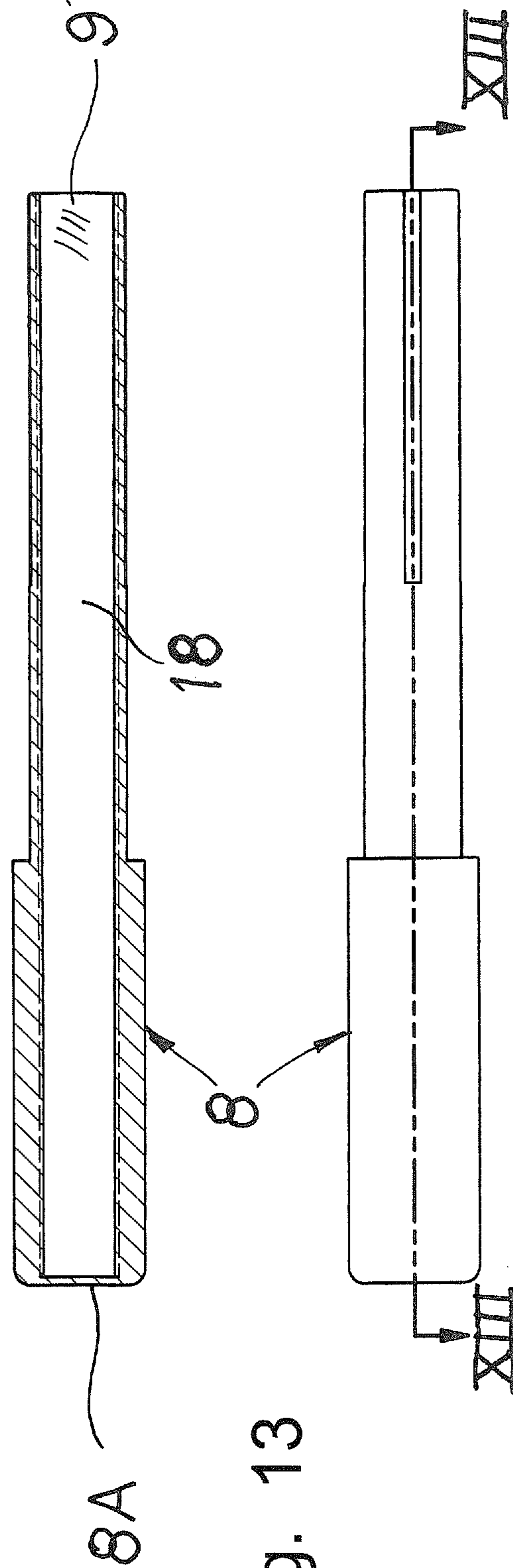
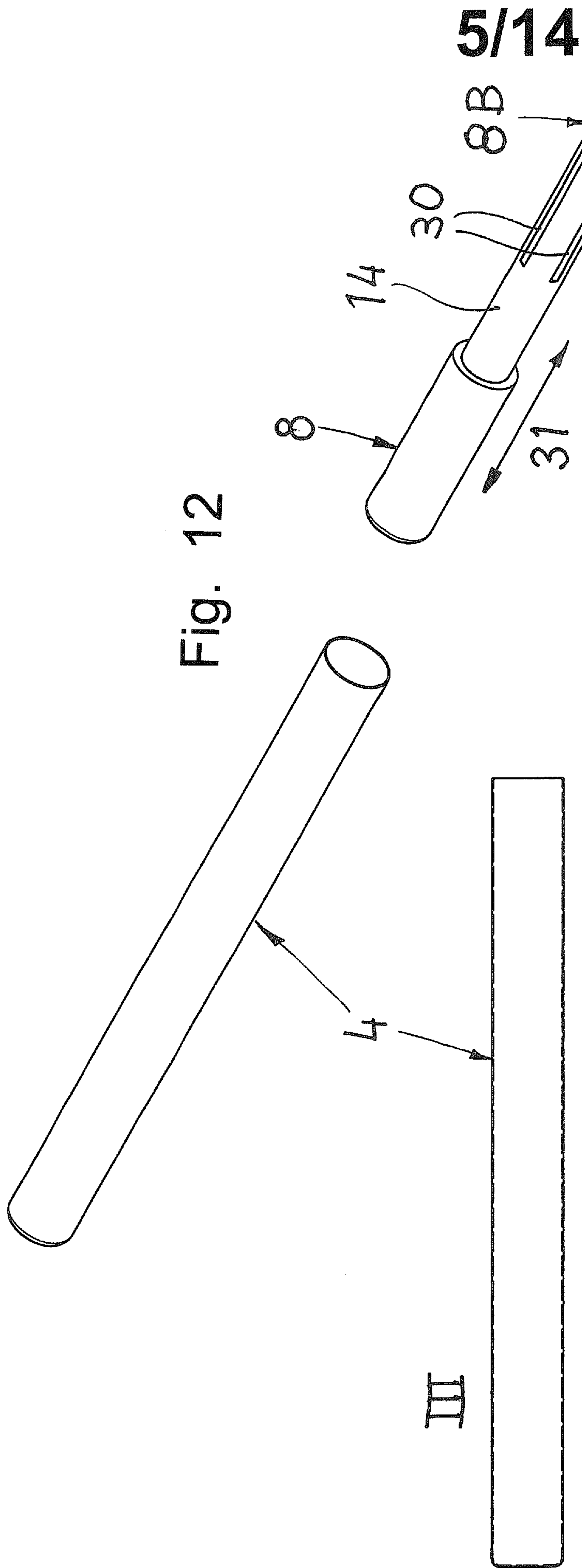

Fig. 8





6/14

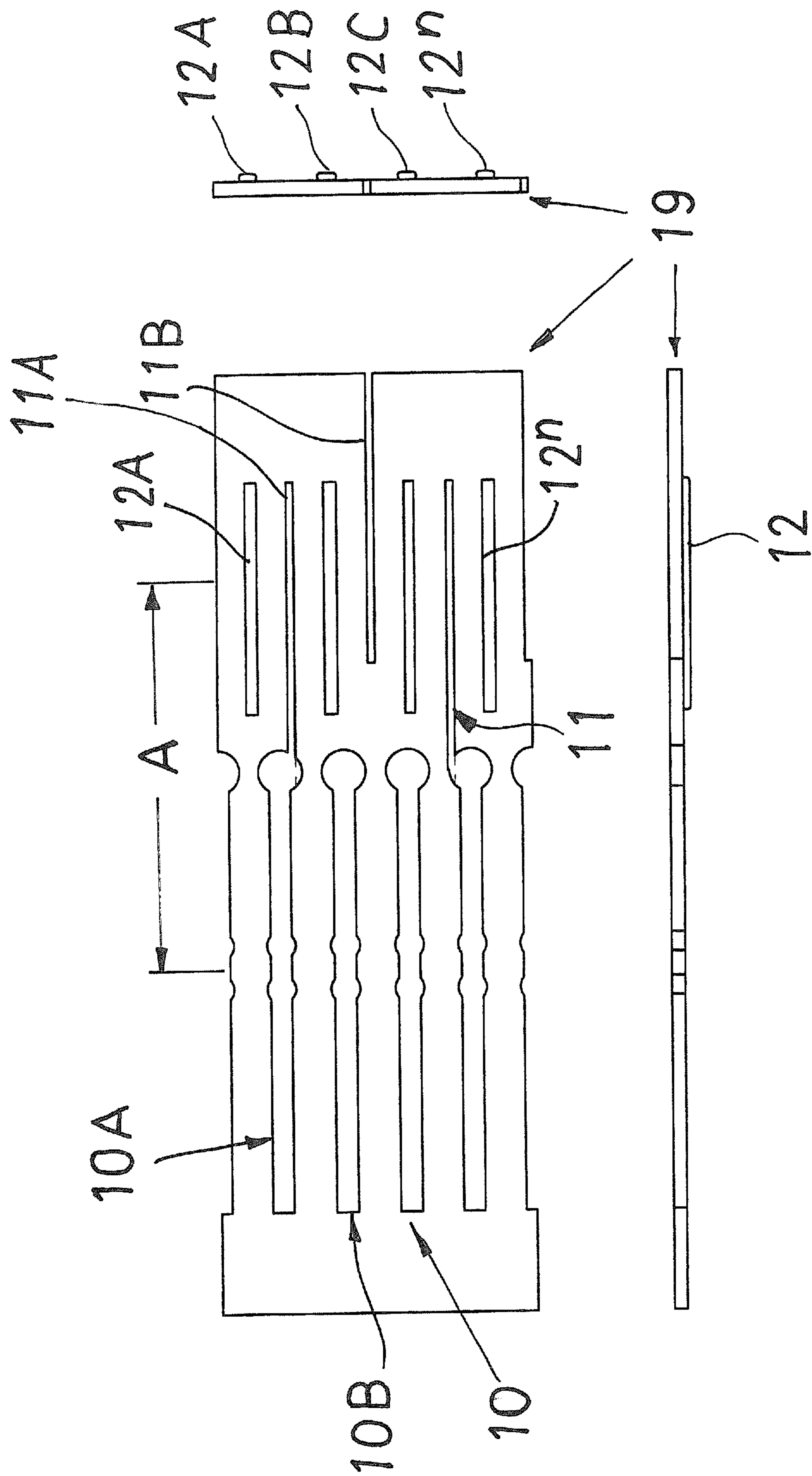

Fig. 14

7/14

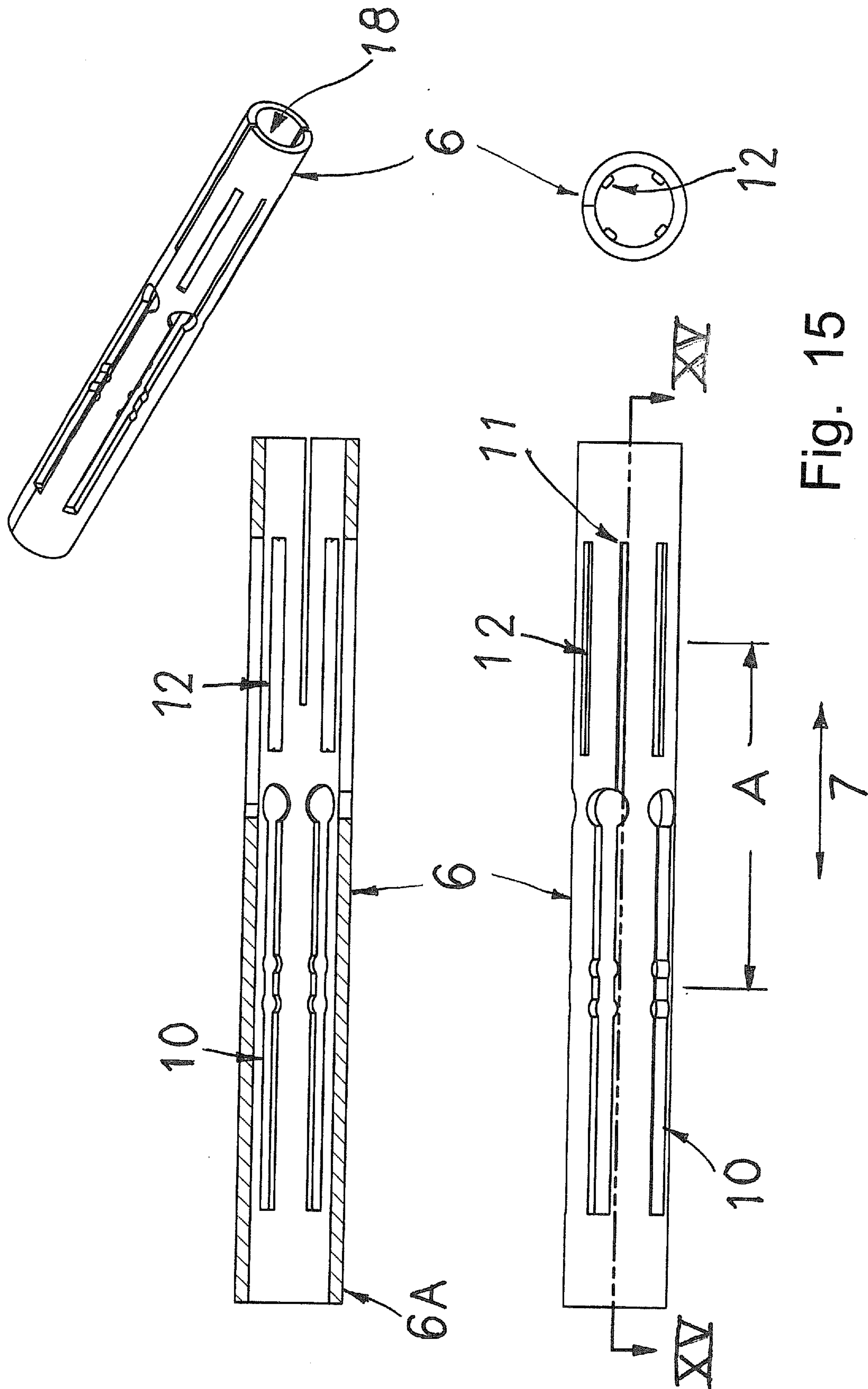

Fig. 15

8/14

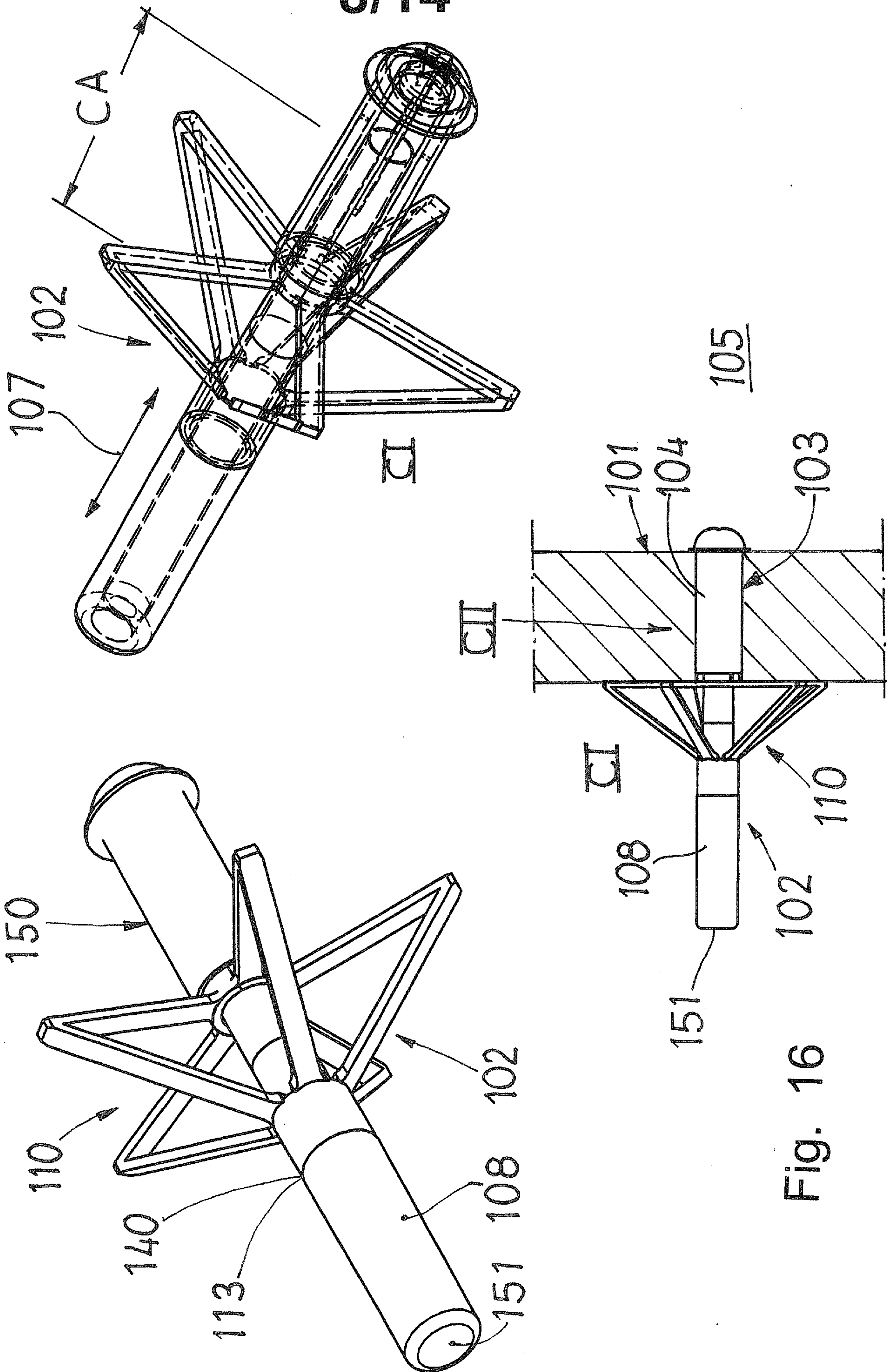

Fig. 16

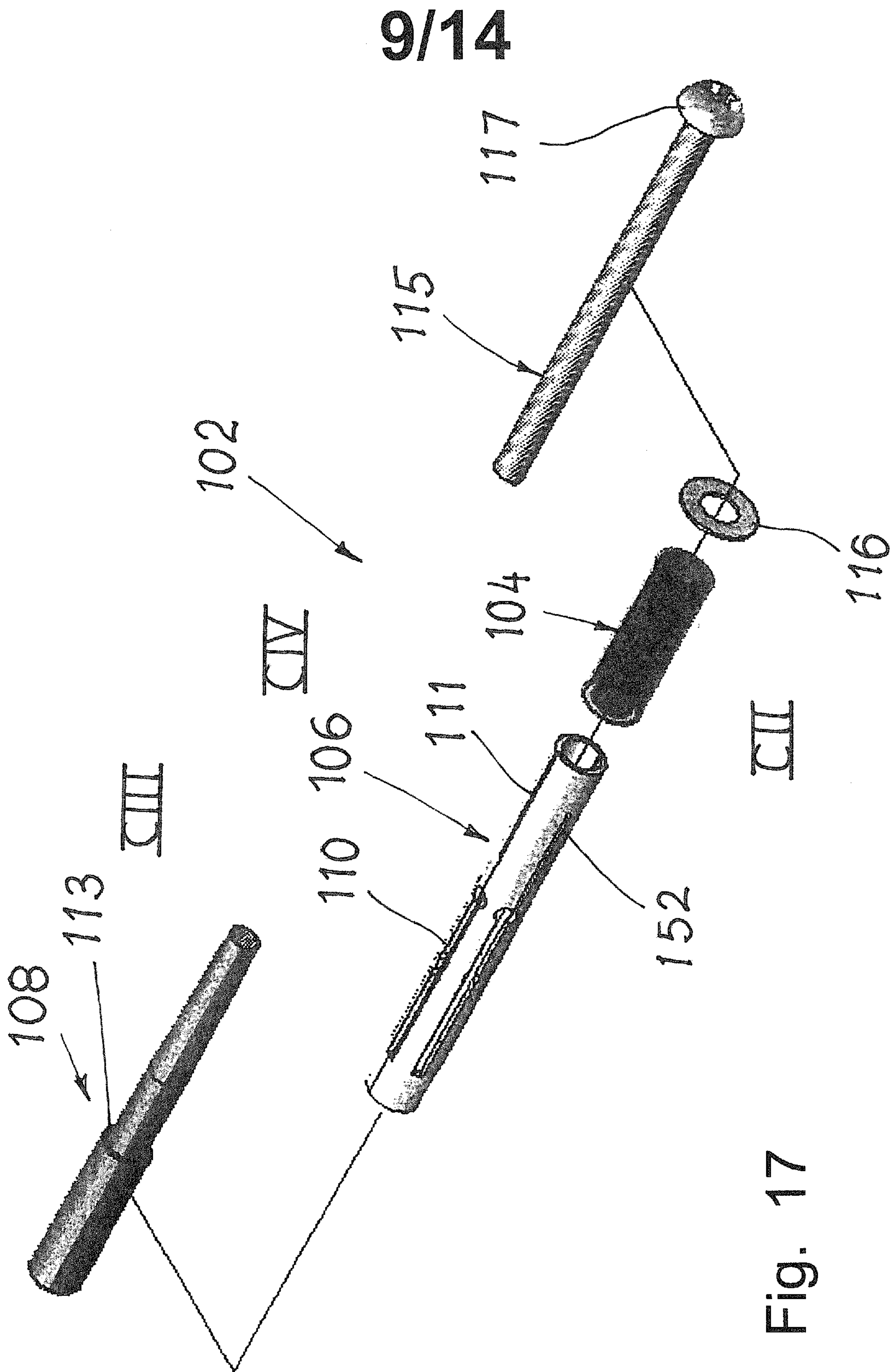
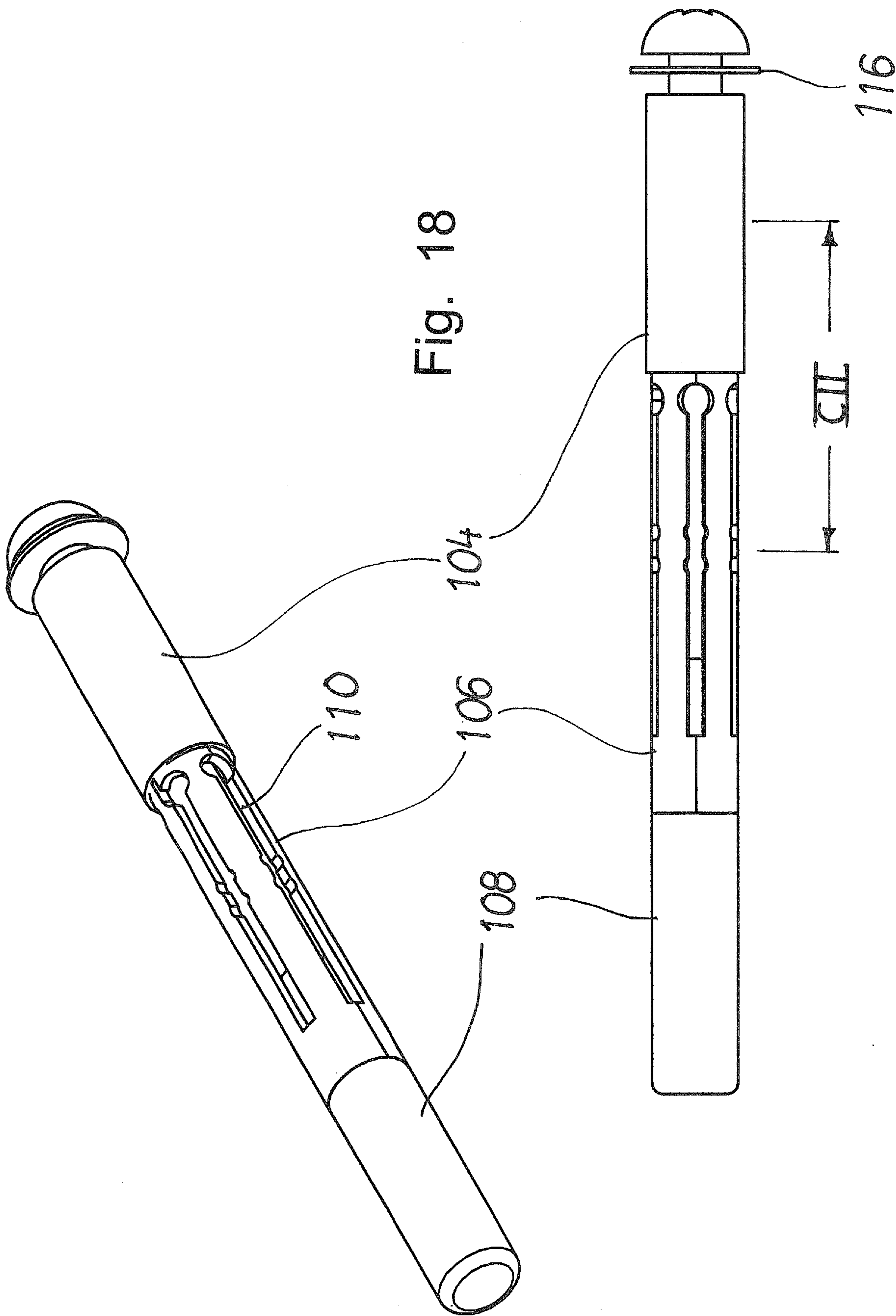

Fig. 17

10/14

Fig. 18



11/14

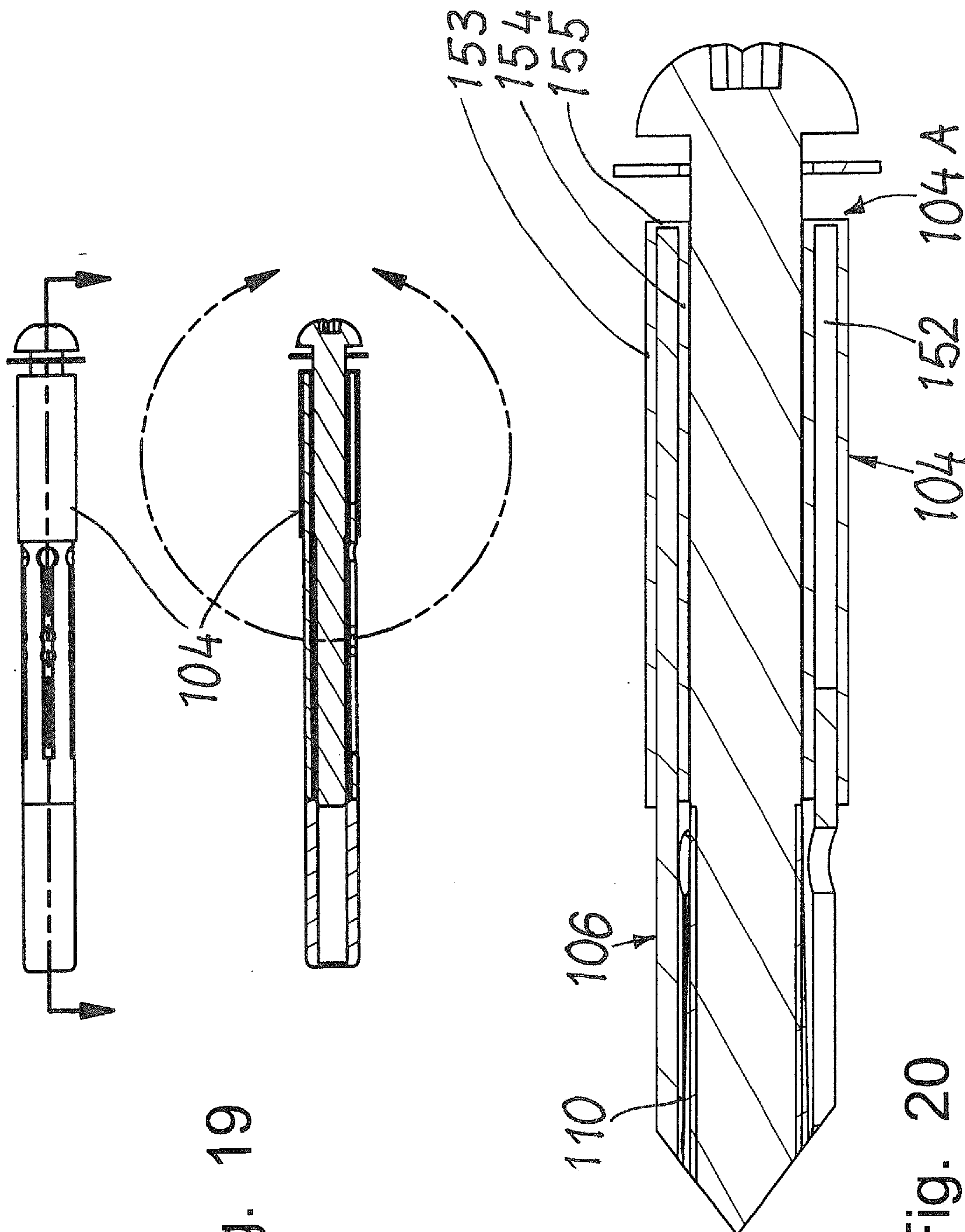

Fig. 19

Fig. 20

12/14

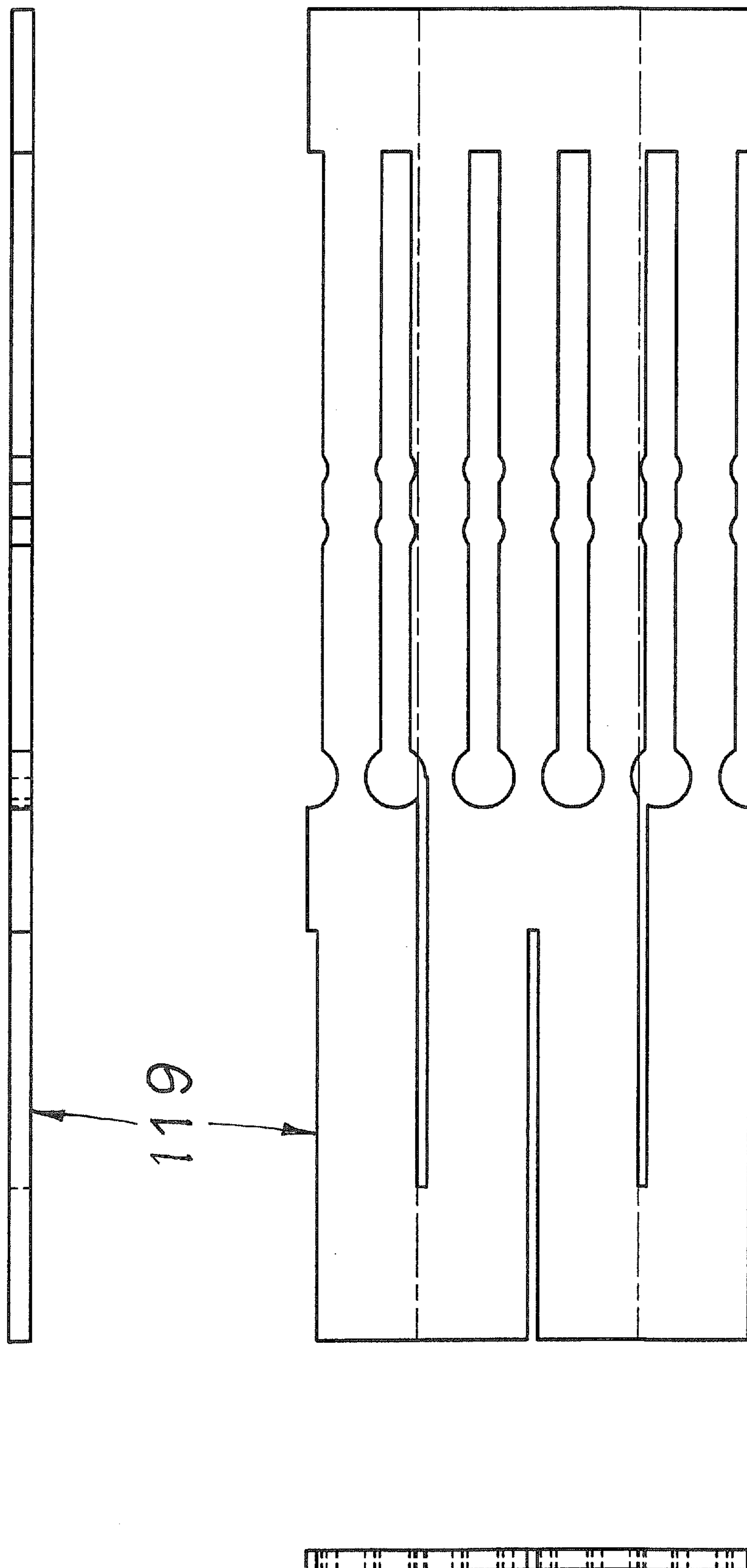

Fig. 21

13/14

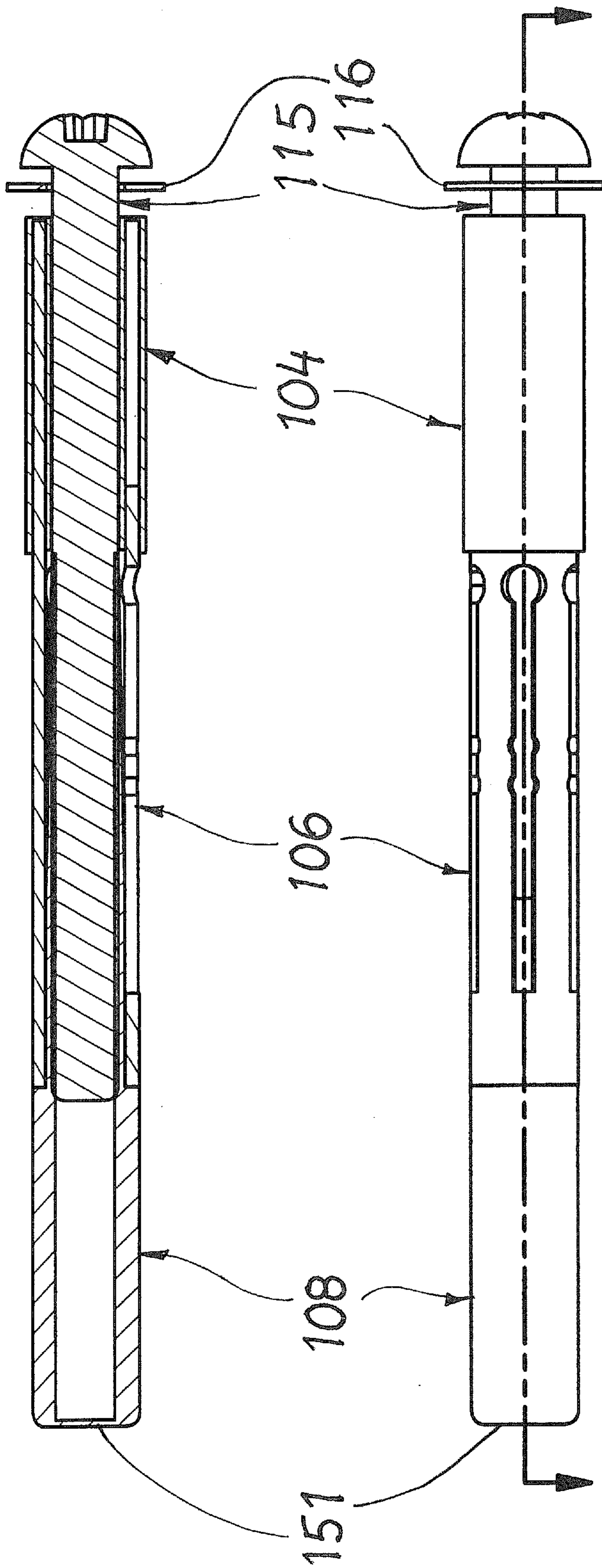
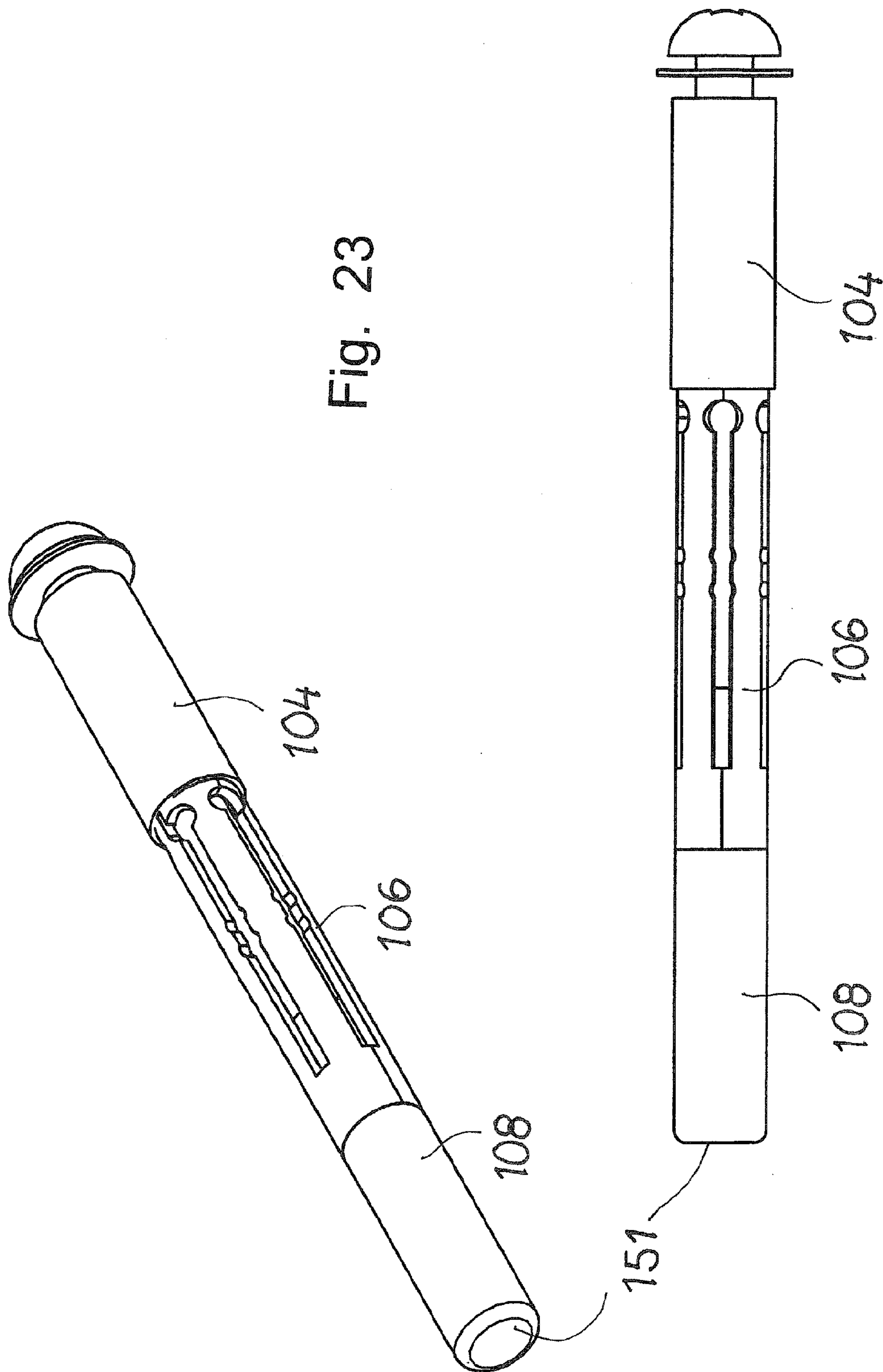

Fig. 22

Fig. 23



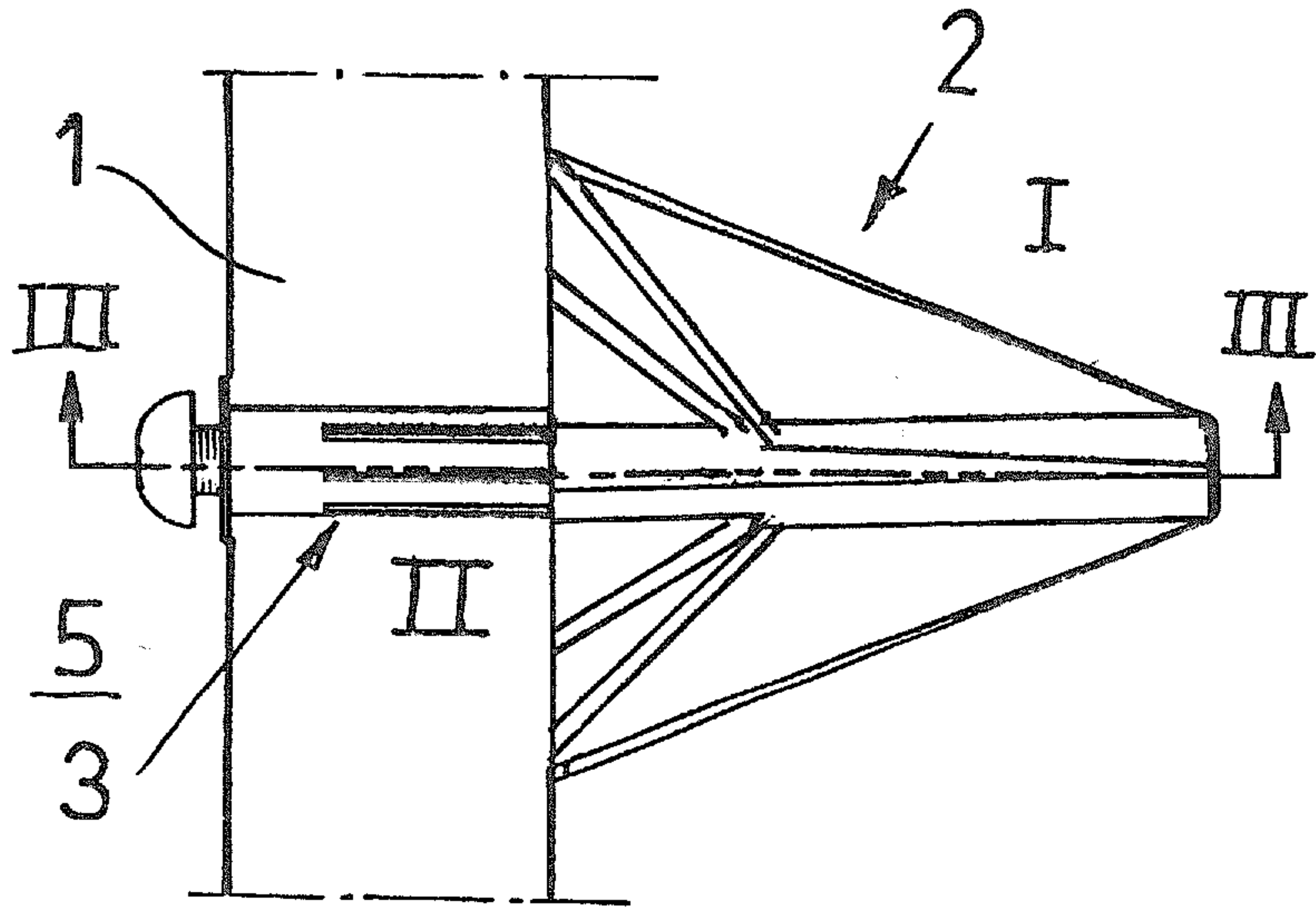

Fig. 2