

T. R. Scovden,

Stop Cock,

N^o 6,414,

Patented May 1, 1849.

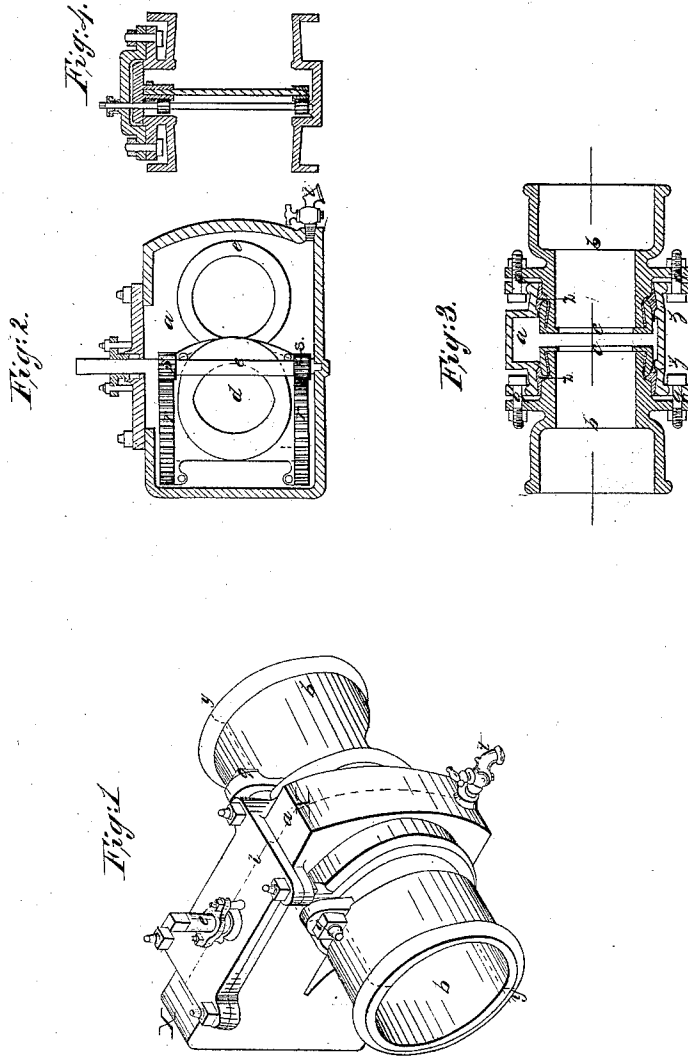

UNITED STATES PATENT OFFICE.

THEODORE R. SCOWDEN, OF CINCINNATI, OHIO.

VALVE-SEAT, &c., FOR WATER-MAINS.

Specification of Letters Patent No. 6,414, dated May 1, 1849.

To all whom it may concern:

Be it known that I, THEODORE R. SCOWDEN, of Cincinnati, Hamilton county, Ohio, have invented a new and useful Stop-Valve for Water-Mains; and I do hereby declare the following to be a full, clear, and exact description of the construction and operation of the same, reference being had to the accompanying drawing, hereunto annexed and made part of this specification, in which—

Figure 1 is a perspective view of a valve for water mains. Fig. 2 is a longitudinal section through the chamber of the same in the line X X. Fig. 3 is a vertical section in the line Y Y. Fig. 4, is a vertical cross section through the breadth of the chamber, the valve being suspended by its flange.

The nature of my invention consists in so constructing a stop valve for water mains in all its mechanical arrangements one with another that be water main large or small the seats can be adjusted to the valve when wear and tear render such adjustment necessary, without being under the necessity of removing the same from its permanent location in the line of the water pipes.

I am aware that stop valves for water mains have been constructed in various ways but they are all liable to objections on account of the expenses involved in excavating around and lifting them out from the line of the pipes when they get out of order. The valve chambers have been cast usually in two pieces, the parts coming together midway (vertically) of the valve box or chamber and the cylindrical mouths or sockets for the pipe attachments being cast one with each part. This mode of construction involves the necessity of removing the whole apparatus whenever the valve and its seats need adjustment the one to the other. The screws and nuts cannot be reached otherwise, and even when reached (supposing they may possibly be turned sufficiently to bear home the seats upon the valve face when the parts are not too much worn for such a result), they are necessarily so numerous that it is tedious to undo and difficult to reset the chamber, because the cylindrical openings to which the valve seats are riveted are a part each of each half of the chamber. On this account also when worn beyond a certain extent (and a trifling wear carries it beyond that point) these seats cannot be borne home by adjustment against

the face of the valve—they must be renewed or the flanges of the valve box or chamber submitted to the planing machine; an operation obviously too costly for such appendages to water mains. The drop valve also has its defects; well known to the engineers of water works and unnecessary to be mentioned here beyond the necessity they involve of difficulties in molding and casting the chamber and its openings and of deep trenching and of being lifted out and re-set when the valve or the seats are in any way worn out or injured.

The plan which I most generally use (except sometimes for small distributing pipes) is represented in section at Figs. 4 and 3 of the annexed drawings and presents the seats attached to movable pipe heads instead of being cast each on a half section of the valve box or chamber, and this arrangement is not a mere mechanical device equivalent to other well known arrangements; but it is a new combination leading to a new and useful result with regard to stop valves for water mains, beyond the freezing point in the ground, and therefore essentially needing some means through which they can when worn be readily, and in their place adjusted. The valve is withdrawn and run in by means of ordinary or self cleaning mortise racks, on each near the top and bottom respectively of a flange suspended on ways at the top of the chamber and projecting from the top and bottom of the valve, and by pinions corresponding thereto on a suitable and appropriately situated shaft, that is to be operated by a winch.

The chamber is cast in one piece with suitable cylindrical flanges, mouths or sockets, having a bead on their inner edges for the insertion of the movable pipe-heads; and in these pipe-heads the annular valve seats are fixed and leaded thereon so that they can be accurately ground to the face of the valve. An opening in the top of the chamber gives access to the valve and is closed by a cap of ordinary structure. By this arrangement great economy in excavating the trench necessary to be opened for the stop valves of large water mains is attained. The heavy expense incurred in making deep intrenchments or excavations (by the old plan of valves sometimes required to be made to more than twice and even three times the depth of the frost line) is rendered unnecessary in setting, repairing or adjusting the

valve and its seats. Besides simplicity, cheapness in and facility of construction and an avoidance of the upright screw, the unwieldy joint in the chamber, and of deep trenches, my valve can be reset, or adjusted to its seats (or they to it) just as it lies in its casing in the ground, as often as their wear and tear may require. This is a result new and useful, not attained by any other stop valve for water mains, but effected in mine by the lugs or ears and screw bolts, which, when operated on by a spanner force the seats up to the face of the valve, the parts yielding to the pressure. It should be remembered too, that this necessity for burying the apparatus in the ground dissimilates it from any other hydraulic, valves, gates, or faucets and such like mechanical devices designed for use in a different medium.

In the drawings (*a*) is the chamber, (*b*) the pipe heads on which the brass valve seats are fixed by running lead between the two, preparatory to the seats being ground.

(*d*) is the valve having a flange with racks (*r*).

(*e*) is the winch shaft having pinions (*s*) thereon to work in the racks and a square at its top to receive the spanner.

(*t*) is a small faucet to throw off depositions.

(*z*) is the soft metal or lead used to close and complete the joint.

(*q*) are the system of lugs, screws nuts and bolts arranged and constructed for the adjustment of the valve and valve seats as already explained.

When the seats have been fixed on the pipe heads and ground, the parts are put in position and filled with sand or meal, a strand of cotton may then be laid between the flange of the valve seat and the socket on the chamber and at the point of contact between the brass flange and the bead on the inner edge of the socket. This having been done, the lead (*z*) is poured in and the joint closed, it having been first ascertained that the valve and its seats are in their exact places and bear home the one on the other. This operation being over, the apparatus is subjected to hydraulic pressure to ascertain if it leaks. If it does not plugs of copper are placed between the lugs and the screws and nuts applied thereto and everything made tight and capable of standing the shocks of carting through the streets after being put in place in the line of the pipe and time and wear and tear require them to be adjusted, the

plugs of copper are knocked out and the spanner applied to the screws and bolts thereby making the parts slip sufficient to bring the seats again home to the valve when the plugs of copper may be replaced.

The drawings will show the sockets of the chamber somewhat larger than the inner ends of the pipe heads, and with beads on their inner edges with which the flanges of the brass valve seats are in contact or nearly so. These seats have flanges which converge as they project back, the outer periphery of the inner end of the pipe heads being formed into dovetailed necks, fitting within the converging flanges and leaving sufficient space between the same for the molten lead which is to close and seal the entire joints between the flanges, pipe-heads and sockets. The lugs on the adjacent parts of the chamber and pipeheads respectively are at a sufficient distance from each other to admit of due approximation under the action of the spanner whenever such action is needed. This adaptation of the parts, the one to the other, enables me to adjust the valve seats to the face of the valve whenever occasion requires it just as it lies in its casing in the line of the water-main and also to execute this important function under all circumstances without lifting the valve out of the ground, a new and useful result hitherto unattained.

Having thus fully described the nature, construction and operation of my invention, I wish it distinctly understood that I do not claim separately any of the parts involved in this combination; but

What I do claim and desire to secure by Letters Patent is—

Arranging and combining substantially as described and represented or in any analogous manner, the several parts involved in the construction of stop valves for water-mains; viz, the chamber (*a*), the movable pipe-head (*b*), the valve seats (*c*), the system of lugs bolts and screw nuts (*q*) the soft metal (*z*) and the valve (*d*) so that buried as they must be beneath the frost-line in the ground, they can be adjusted in the matter of their valves and valve seats without being removed from their permanent location in the line of the water main.

T. R. SCOWDEN.

Attest:

THOS. G. CLINTON,
GEO. H. KNIGHT.